

Power and charging

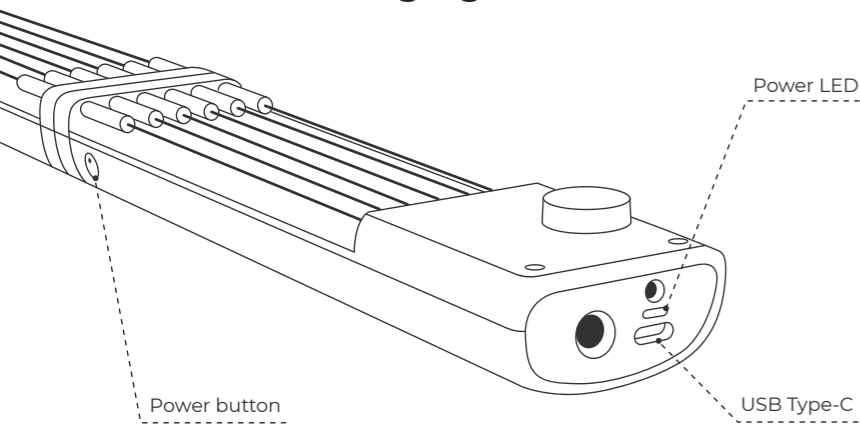

Power button indication

< 5%	5-100 %	Description
		Jammy is OFF
		Jammy is turning on or off
		Jammy is ON
		Jammy is in Bluetooth pairing mode

Power LED indication

Battery is 100% charged Battery is charging



playjammy.com

Assembly instructions

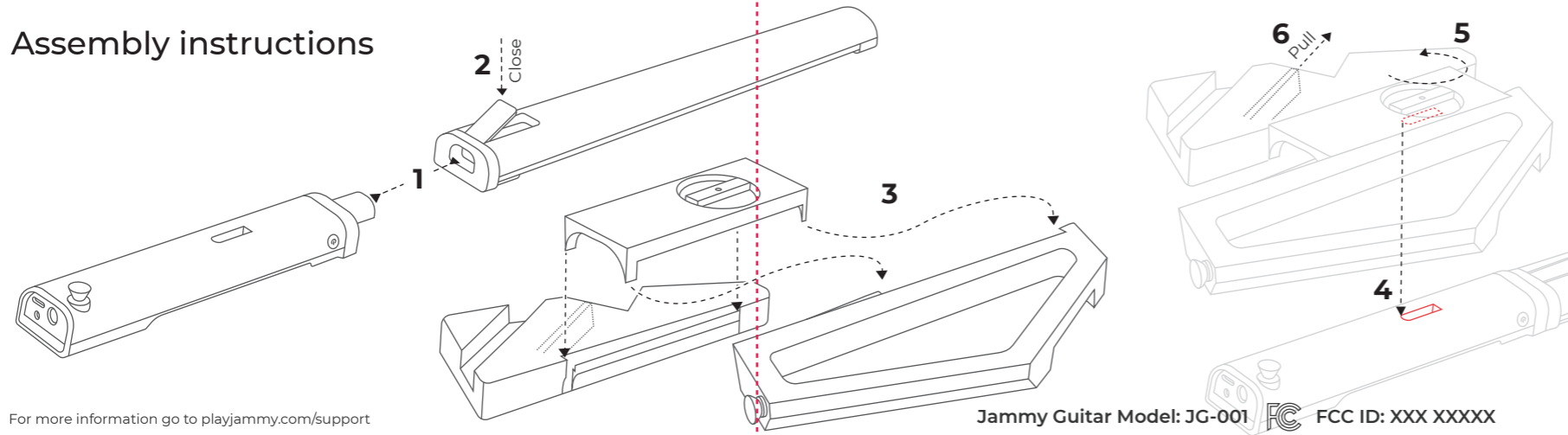

For more information go to playjammy.com/support

Jammy Guitar Model: JG-001 FCC ID: XXX XXXXX

Mobile app



Switch among different acoustic and electric guitars and onboard effects pedals' configurations



Change guitar tuning



Use metronome



Learn to improvise along to backing tracks in different genres with the Jammy mobile app



Scan this QR code to learn more about the Jammy mobile app





**Dear rocker,
Thank you for purchasing Jammy.**

Your Jammy product is covered against manufacturer's defects from the date of purchase and during one Year. Please read the terms of the limited warranty we offer in this document.

JAMMY LIMITED WARRANTY TERMS AND CONDITIONS

RnD64 Inc. hereby guarantees to the original retail purchaser ("Consumer" or "You") that Jammy Portable Electronic Instrument ("Jammy" or "Product") is free from defects in materials and workmanship under normal use in accordance with the operating instructions and pursuant to the following terms and conditions.

The limited warranty period is ONE (1) YEAR (should legislation of your country provide longer period for warranty coverage, this longer period will apply) from the date of original purchase from the authorized distributor/resellers documented by a valid proof of purchase - e.g. receipt, invoice. If you order Jammy via RND64 or an authorized distributor/reseller's web-store or via Indiegogo warranty period starts from the date you received the Product as confirmed by a postal delivery document. Non-compliance of the proof of purchase/receipt may delay or void the application of the limited warranty. Second hand purchases are not covered.

During the limited warranty period, RnD64 Inc. or its authorized service provider will, at their own discretion either:

- repair defective product using new or refurbished parts and restore it to its optimum working condition;
- replace the defective Product with a new Product;
- refund cost of the defective Product including its delivery cost related to the original purchase.

Obtaining Warranty Service

To obtain warranty service, you must deliver the Product, freight prepaid, in either its original packaging or packaging providing an equal degree of protection, to the address specified by RnD64 Inc. . In accordance with applicable law, RnD64 Inc. may require that you furnish proof of purchase details and/or comply with registration requirements before receiving warranty service. For specific instructions on how to obtain warranty service please email us at support@playjammy.com

This limited warranty does not cover:

- claims for loss of use/inconveniences due to any malfunctions, damages caused by lightning, exposure to liquids, fire, computer viruses, extreme temperatures, negligence, misuse or improper handling/operations;
- counterfeit Products, or Products purchased on a second hand market, not from authorized distributor/reseller;
- 'consumable' parts of your Product – strings, batteries, straps, accessories, mechanical and replaceable parts, (unless damage has occurred due to a defect in materials or workmanship);
- cosmetic damage, including but not limited to scratches, dents and broken plastic on ports unless failure has occurred due to a defect in materials or workmanship;
- Products that has been under repairs, were subject to modification or alterations (including its firmware, opening cover) by unauthorized service organizations or persons;
- Products if its labels specifying product model, serial numbers are removed or altered;
- Defects or parts requiring replacement due to ordinary wear and tear, corrosion, rust or stains, scratches, dents on the casing or paintwork of the Product;
- Defects or faults in Products, which have been used for commercial purposes – rented/leased or have been otherwise subject to non-household use;

Software distributed by RnD64 Inc., its affiliates (including, but not limited to system software) is not covered under this Limited Warranty. Refer to the licensing agreement accompanying the software for details of your rights with respect to its use. RnD64 Inc. does does not warrant that the operation of the product will be uninterrupted or error-free.

RnD64 Inc. obligations under this limited warranty are limited to the repair, replacement or of the defective Product or refund of its cost. Except as set forth above, there are no other express or implied warranties, conditions or other terms implied by statute or common law. RnD64 Inc. total liability for damages relating to or arising from out of purchase or use of the Product regardless of the type of damages shall not exceed the original purchase price paid for the Product.

However in no event RnD64 Inc., its employees, retailers and distributors will be liable for any indirect, punitive, special incidental, indirect or consequential damages (including without limitation - loss revenue, loss profits, failure to realize savings or other benefits, loss of opportunity, loss of goodwill, damage to, compromise or corruption of data, whenever or not RnD64 Inc. has been advised of the possibility of such damages. Without limiting the foregoing, purchaser assumes all risk and liability for loss, damage of injury to purchaser and purchaser's property and to others and their property arising out of the use, misuse or inability to use the Product sold by RnD64 Inc. not caused directly by the negligence of RnD64 Inc. This limited warranty does not affect the Consumer's statutory rights under law. Should the terms of this warranty limit any of your rights under the applicable law – its provision should apply.

No carrier, retailer, agent, dealer or any employee thereof is authorized to make any modifications to this limited warranty and You should not rely on any such representations. RnD64 Inc. reserves the right to amend the terms and conditions if necessary.

FCC Statement

Jammy Guitar Model: JG-001  FCC ID: 2AR6VJG001

Changes or modifications not expressly approved by the party responsible for compliance could void the user's authority to operate the equipment.

This equipment has been tested and found to comply with the limits for a Class B digital device, pursuant to Part 15 of the FCC Rules. These limits are designed to provide reasonable protection against harmful interference in a residential installation. This equipment generates uses and can radiate radio frequency energy and, if not installed and used in accordance with the instructions, may cause harmful interference to radio communications. However, there is no guarantee that interference will not occur in a particular installation. If this equipment does cause harmful interference to radio or television reception, which can be determined by turning the equipment off and on, the user is encouraged to try to correct the interference by one or more of the following measures:

- Reorient or relocate the receiving antenna.
- Increase the separation between the equipment and receiver.
- Connect the equipment into an outlet on a circuit different from that to which the receiver is connected.
- Consult the dealer or an experienced radio/TV technician for help

This device complies with part 15 of the FCC rules. Operation is subject to the following two conditions (1) this device may not cause harmful interference, and (2) this device must accept any interference received, including interference that may cause undesired operation.

This device has been evaluated to meet general RF exposure requirement. The device can be used in portable exposure condition without restriction.