



FCC Radio Test Report

FCC ID: 2AR5M-K1000

Original Grant

Report No. : TB-FCC163070
Applicant : Find-Me Technologies Pty Ltd.
Equipment Under Test (EUT)
EUT Name : K.I.T.
Model No. : K1000
Series Model No. : N/A
Brand Name : K.I.T.
Receipt Date : 2018-12-05
Test Date : 2018-12-06 to 2019-02-25
Issue Date : 2019-02-28
Standards : FCC Part 2
FCC Part 22 Subpart H, FCC Part 24 Subpart E, 2018
ANSI/TIAC63.26: 2015
Conclusions : **PASS**
In the configuration tested, the EUT complied with the standards specified above,
The EUT technically complies with the FCC requirements

Test/Witness Engineer :  Jason Xu
Engineer Supervisor :  Ivan Su
Engineer Manager :  Ray Lai



This report details the results of the testing carried out on one sample. The results contained in this test report do not relate to other samples of the same product. The manufacturer should ensure that all products in series production are in conformity with the product sample detailed in the report.

Contents

CONTENTS.....	2
1. GENERAL INFORMATION ABOUT EUT	5
1.1 Client Information.....	5
1.2 General Description of EUT (Equipment Under Test)	5
1.3 Block Diagram Showing the Configuration of System Tested.....	6
1.4 Description of Support Units	6
1.5 Description of Test Mode.....	7
1.6 Measurement Uncertainty	8
1.7 Test Facility.....	8
2. TEST SUMMARY	9
3. TEST EQUIPMENT.....	10
4. FREQUENCY STABILITY	11
4.1 Test Standard and Requirement	11
4.2 Test Setup.....	11
4.3 Test Procedure.....	12
4.4 EUT Operating Condition	12
4.5 Test Data.....	12
5. CONDUCTED RF OUTPUT POWER.....	13
5.1 Test Standard and Limit.....	13
5.2 Test Setup.....	13
5.3 Test Procedure.....	13
5.4 EUT Operating Condition	13
5.5 Test Data.....	13
6. PEAK-AVERAGE RATIO.....	14
6.1 Test Standard and Limit.....	14
6.2 Test Setup.....	14
6.3 Test Procedure.....	14
6.4 EUT Operating Condition	14
6.5 Test Data.....	14
7. RADIATED OUTPUT POWER	15
7.1 Test Standard and Limit.....	15
7.2 Test Setup.....	15
7.3 Test Procedure.....	16
7.4 EUT Operating Condition	16
7.5 Test Data.....	16
8. OCCUPIED BANDWIDTH.....	17
8.1 Test Standard and Limit.....	17
8.2 Test Setup.....	17
8.3 Test Procedure.....	17

8.4 EUT Operating Condition	18
8.5 Test Data.....	18
9. CONDUCTED OUT OF BAND EMISSIONS.....	19
9.1 Test Standard and Limit.....	19
9.2 Test Setup.....	19
9.3 Test Procedure.....	19
9.4 EUT Operating Condition	19
9.5 Test Data.....	19
10. BAND EDGE TEST	20
10.1 Test Standard and Limit	20
10.2 Test Setup.....	20
10.3 Test Procedure.....	20
10.4 EUT Operating Condition	20
10.5 Test Data.....	20
11. RADIATED OUT BAND OF EMISSIONS.....	21
11.1 Test Standard and Limit	21
11.2 Test Setup.....	21
11.3 Test Procedure.....	21
11.4 EUT Operating Condition	22
11.5 Test Data.....	22
ATTACHMENT A--FREQUENCY STABILITY	23
ATTACHMENT B--CONDUCTED RF OUTPUT POWER	25
ATTACHMENT C--PEAK-AVERAGE RATIO	27
ATTACHMENT D-- RADIATED OUTPUT POWER.....	29
ATTACHMENT E--OCCUPIED BANDWIDTH.....	30
ATTACHMENT F--CONDUCTED OUT OF BAND EMISSIONS.....	39
ATTACHMENT G-- BAND EDGE TEST.....	51
ATTACHMENT H--RADIATED OUT BAND OF EMISSIONS	55

1. General Information about EUT

1.1 Client Information

Applicant	:	Find-Me Technologies Pty Ltd
Address	:	PO Box 2494, Fortitude valley, Old 4006
Manufacturer	:	Shenzhen Raysans Technologies Co.,Ltd.
Address	:	Block 1, Runheng Dingfeng High-tech Industrial Park, Yongfuyuan First Road, Bao'an District, Shenzhen, China

1.2 General Description of EUT (Equipment Under Test)

EUT Name	:	K.I.T.
Models No.	:	K1000
Model Different	:	N/A
Product Description	:	Frequency Bands: UMTS FDD Band II; UMTS FDD Band V
	:	UMTS Band II Power: Cond:22.35 dBm EIRP:21.25 dBm
	:	UMTS Band V Power: Cond: 22.13 dBm ERP:21.23 dBm
	:	Antenna Gain: 0.224 dB FPC Antenna
	:	Modulation Type: UMTS:QPSK
FCC Operating Frequency	:	UMTS Band II: 1852.40MHz-1907.60MHz UMTS Band V:826.40MHz-846.60MHz
Emission Designator	:	UMTS Band V: 4M90F9W, UMTS Band II: 4M90F9W
Power Rating	:	DC 5V 1A Supply from AC/DC Adapter. DC 3.7V 280 mA Supply from Li-ion Battery.
Software Version	:	MP
Hardware Version	:	MP
Connecting I/O Port(S)	:	Please refer to the User's Manual

Note:

For a more detailed features description, please refer to the manufacturer's specifications or the User's Manual.

1.3 Block Diagram Showing the Configuration of System Tested

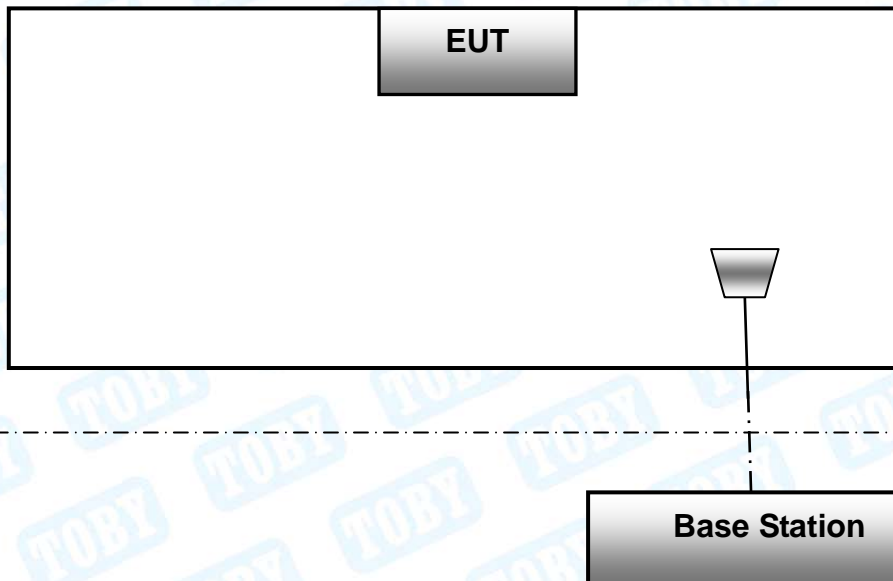

The above block diagram of setup is the normal mode. And more detail please refer to the test setup of each test item of bellow.

1.4 Description of Support Units

The EUT has been tested as an independent unit.

1.5 Description of Test Mode

To investigate the maximum EMI emission characteristics generates from EUT, the test system was pre-scanning tested base on the consideration of following EUT operation mode or test configuration mode which possible have effect on EMI emission level. Each of these EUT operation mode(s) or test configuration mode(s) mentioned follow was evaluated respectively.

During all testing, EUT is link mode with base station at maximum power level. The spurious emission measurements were carried out in semi-anechoic chamber with 3-meter test range. Frequency range investigated for radiated emission as below:

1. 9kHz~10GHz for GSM850 and UMTS Band V.
2. 9kHz~20GHz for PCS1900 and UMTS Band II.

Test Channel		
Mode	Channel	Frequency(MHz)
UMTS Band V	4132	826.40
	4183	836.60
	4233	846.60
UMTS Band II	9262	1852.40
	9400	1880.00
	9538	1907.60
Test Mode		Description
HSDPA UMTS Band V		highest , middle, lowest channels
HSUPA UMTS Band V		highest , middle, lowest channels
HSDPA UMTS Band II		highest , middle, lowest channels
HSUPA UMTS Band II		highest , middle, lowest channels

Note:

- (1) The measurements are performed at the highest, middle, lowest available channels.
- (2) During the testing procedure, the EUT is in link mode with base station emulator at maximum power level in each test mode.
- (3) The EUT has HSDPA, HSUPA functions in UMTS band II and UMTS band V, and after pre-testing, RMC mode is the worst case for all the emission tests.
- (4) The EUT is considered a portable unit; it was pre-tested on the positioned of each 3 axis, X-plane, Y-plane and Z-plane. The worst case was found positioned on Z-plane as the normal use. Therefore only the test data of this Z-plane was used for radiated emission measurement test.

1.6 Measurement Uncertainty

Test Item	Parameters	Expanded Uncertainty (U _{Lab})
Conducted Emission	Level Accuracy: 9kHz~150kHz	±3.42 dB
	150kHz to 30MHz	±3.42 dB
Radiated Emission	Level Accuracy: 9kHz to 30 MHz	±4.60 dB
Radiated Emission	Level Accuracy: 30MHz to 1000 MHz	±4.40 dB
Radiated Emission	Level Accuracy: Above 1000MHz	±4.20 dB

1.7 Test Facility

The testing was performed by the Shenzhen Toby Technology Co., Ltd., in their facilities located at:1A/F., Bldg.6, Yusheng Industrial Zone, The National Road No.107 Xixiang Section 467, Xixiang, Bao'an, Shenzhen, Guangdong, China.

At the time of testing, the following bodies accredited the Laboratory:

CNAS (L5813)

The Laboratory has been accredited by CNAS to ISO/IEC 17025: 2005 General Requirements for the Competence of Testing and Calibration Laboratories for the competence in the field of testing. And the Registration No.: CNAS L5813.

A2LA Certificate No.: 4750.01

The laboratory has been accredited by American Association for Laboratory Accreditation(A2LA) to ISO/IEC 17025: 2005 General Requirements for the Competence of Testing and Calibration Laboratories for the technical competence in the field of Electrical Testing. And the A2LA Certificate No.: 4750.01. FCC Accredited Test Site Number: 854351.

IC Registration No.: (11950A-1)

The Laboratory has been registered by Certification and Engineering Bureau of Industry Canada for radio equipment testing. The site registration: Site# 11950A-1.

2. Test Summary

Test Standards and Test Results			
Standard	Document Title		
FCC Part 2 (10-1-05 Edition)	Frequency Allocations and Radio Treaty Matters; General Rules and Regulations		
FCC Part 22 (10-1-05 Edition)	Public Mobile Services		
FCC Part 24 (10-1-05 Edition)	Personal Communications Services		
Standard Section	Test Item	Judgment	Remark
2.1046	Conducted RF Output Power	PASS	N/A
24.232(d)	Peak-Average Ratio	PASS	N/A
2.1049; 22.917; 24.238	99% & -26 dB Occupied Bandwidth	PASS	N/A
2.1055; 22.355; 24.235	Frequency Stability	PASS	N/A
2.1051; 2.1057; 22.917; 24.238	Conducted Out of Band Emissions	PASS	N/A
2.1051; 2.1057; 22.917; 24.238	Band Edge	PASS	N/A
22.913; 24.238	Transmitter Radiated Power (EIRP/ERP)	PASS	N/A
2.1053; 2.1057; 22.917; 24.238	Radiated Out of Band Emissions	PASS	N/A
Note: N/A is an abbreviation for Not Applicable.			

3. Test Equipment

Radiation Emission Test					
Equipment	Manufacturer	Model No.	Serial No.	Last Cal.	Cal. Due Date
Spectrum Analyzer	Agilent	E4407B	MY45106456	Jul. 18, 2018	Jul. 17, 2019
EMI Test Receiver	Rohde & Schwarz	ESPI	100010/007	Jul. 18, 2018	Jul. 17, 2019
Bilog Antenna	ETS-LINDGREN	3142E	00117537	Mar.16, 2018	Mar. 15, 2019
Bilog Antenna	ETS-LINDGREN	3142E	00117542	Mar.16, 2018	Mar. 15, 2019
Horn Antenna	ETS-LINDGREN	3117	00143207	Mar.16, 2018	Mar. 15, 2019
Horn Antenna	ETS-LINDGREN	3117	00143209	Mar.16, 2018	Mar. 15, 2019
Loop Antenna	SCHWARZBECK	FMZB 1519 B	1519B-059	Jul. 14, 2018	Jul. 13, 2019
Pre-amplifier	Sonoma	310N	185903	Mar.17, 2018	Mar. 16, 2019
Pre-amplifier	HP	8449B	3008A00849	Mar.17, 2018	Mar. 16, 2019
Cable	HUBER+SUHNER	100	SUCOFLEX	Mar.17, 2018	Mar. 16, 2019
Positioning Controller	ETS-LINDGREN	2090	N/A	N/A	N/A
Antenna Conducted Emission					
Equipment	Manufacturer	Model No.	Serial No.	Last Cal.	Cal. Due Date
Spectrum Analyzer	Agilent	E4407B	MY45106456	Jul. 18, 2018	Jul. 17, 2019
Spectrum Analyzer	Rohde & Schwarz	ESCI	100010/007	Jul. 18, 2018	Jul. 17, 2019
MXA Signal Analyzer	Agilent	N9020A	MY49100060	Sep. 15, 2018	Sep. 14, 2019
Vector Signal Generator	Agilent	N5182A	MY50141294	Sep. 15, 2018	Sep. 14, 2019
Analog Signal Generator	Agilent	N5181A	MY50141953	Sep. 15, 2018	Sep. 14, 2019
RF Power Sensor	DARE!! Instruments	RadiPowerRPR3006W	17I00015SNO26	Sep. 15, 2018	Sep. 14, 2019
	DARE!! Instruments	RadiPowerRPR3006W	17I00015SNO29	Sep. 15, 2018	Sep. 14, 2019
	DARE!! Instruments	RadiPowerRPR3006W	17I00015SNO31	Sep. 15, 2018	Sep. 14, 2019
	DARE!! Instruments	RadiPowerRPR3006W	17I00015SNO33	Sep. 15, 2018	Sep. 14, 2019
Wideband Radio Communication Tester	Rohde & Schwarz	CMW500	144382	Sep. 15, 2018	Sep. 14, 2019
Universal Radio Communication Tester	Rohde&Schwarz	CMU200	103903	Jul. 18, 2018	Jul. 17, 2019

4. Frequency Stability

4.1 Test Standard and Requirement

4.1.1 Test Standard

FCC Part 2.1055

FCC Part 22.355

FCC Part 24.235

4.1.2 Requirement

According to FCC section 22.355 and FCC section 24.235, the frequency stability shall be sufficient to ensure that the fundamental emission stays within the authorized frequency block. According to FCC section 2.1055, the test conditions are:

(1) Temperature:

The temperature is varied from -30°C to $+50^{\circ}\text{C}$ at intervals of not more than 10°C .

(2) Primary Supply Voltage:

For hand carried battery powered equipment, the primary supply voltage is reduced to the battery operating end point which shall be specified by the manufacture. The supply voltage shall be measured at input to the cable normally provide with the equipment, or at the power supply terminals if cables are not normally provided.

4.2 Test Setup

For Temperature Test:

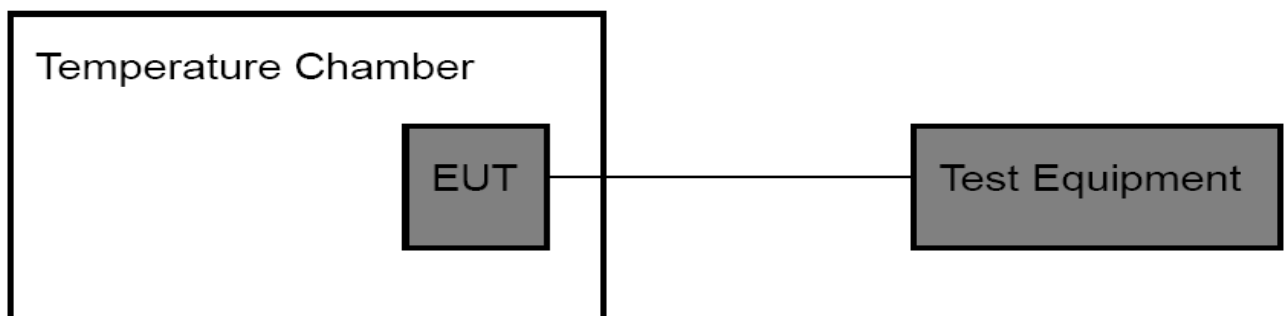

For Voltage Test:

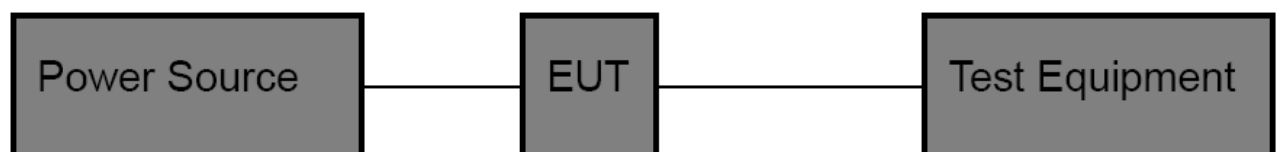

4.3 Test Procedure

Test Procedures for Temperature Variation:

- (1) The EUT was set up in the thermal chamber and connected with the base station.
- (2) With power off, the temperature was decreased to -30°C and the EUT was stabilized for three hours. Power was applied and the maximum change in frequency was recorded within one minute.
- (3) With power off, the temperature was raised in 10°C set up to 50°C and the EUT was stabilized for three hours. Power was applied and the maximum change in frequency was recorded within one minute.
- (4) If the EUT cannot be turned on at -30°C , the testing lowest temperature will be raised in 10°C step until the EUT can be turned on.

Test Procedures for Voltage Variation:

- (1) The EUT was placed in a temperature chamber at $25 \pm 5^{\circ}\text{C}$ and connected with the base station.
- (2) Reduce the input voltage to specify extreme voltage variation ($\pm 15\%$) and endpoint, record the maximum frequency change.
- (3) The variation in frequency was measured for the worst case.

4.4 EUT Operating Condition

The Equipment Under Test was set to Communication with the Base Station.

4.5 Test Data

Please refer to the Attachment A.

5. Conducted RF Output Power

5.1 Test Standard and Limit

5.1.1 Test Standard

FCC Part 2: 2.1046

FCC Part 22H : 22.913 (a)

FCC Part 24E: 24.232 (c)

5.1.2 Test Limit

GSM850/UMTS Band V	PCS 1900/UMTS Band II
38.5 dBm (ERP)	33 dBm (EIRP)

5.2 Test Setup

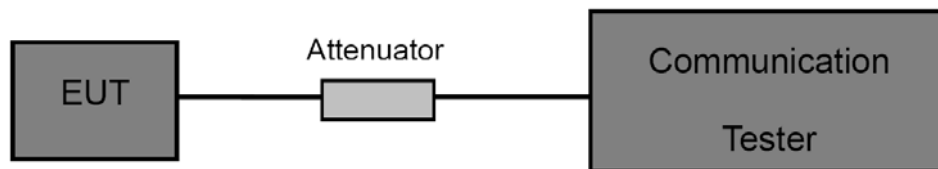

5.3 Test Procedure

- (1) The EUT is coupled to the Base Station with the suitable Attenuator, the path loss is calibrated to correct the reading.
- (2) A call is set up by the Base Station to the generic call set up procedure.
- (3) Set EUT at maximum power level through base station by power level command.
- (4) Then read record the power value from the Base Station in dBm.

5.4 EUT Operating Condition

The EUT was continuously connected with the Base station and transmitting in the max power during the test.

5.5 Test Data

Please refer to the Attachment B.

6. Peak-Average Ratio

6.1 Test Standard and Limit

6.1.1 Test Standard

FCC Part 24E: 24.232 (d)

6.1.2 Test Limit

PCS 1900 /UMTS Band II

The peak-to-average ratio (PAR) of the transmission may not exceed 13 dB.

6.2 Test Setup

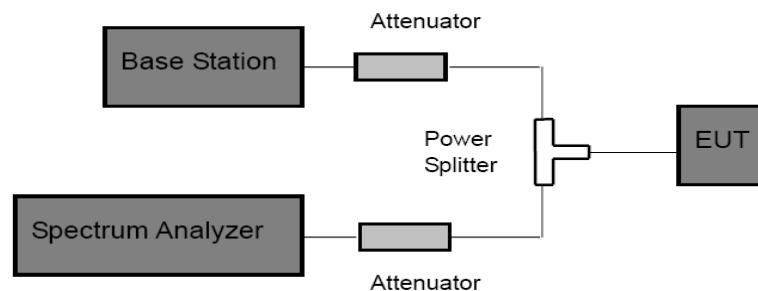

6.3 Test Procedure

According with KDB 971168

- (1) The signal analyzer's CCDF measurement profile is enabled.
- (2) Frequency = carrier center frequency.
- (3) Measurement BW > Emission bandwidth of signal.
- (4) The signal analyzer was set to collect one million samples to generate the CCDF curve.
- (5) The measurement interval was set depending on the type of signal analyzed. For continuous signals (>98% duty cycle), the measurement interval was set to 1ms. For burst transmissions, the spectrum analyzer is set to use an internal "RF Burst" trigger that is synced with an incoming pulse and the measurement interval is set to less than the duration of the "on time" of one burst to ensure that energy is only captured during a time in which of the transmitter is operating at maximum power.

6.4 EUT Operating Condition

The EUT was continuously connected with the Base station and transmitting in the max power during the test.

6.5 Test Data

Please refer to the Attachment C.

7. Radiated Output Power

7.1 Test Standard and Limit

7.1.1 Test Standard

FCC Part 22H: 22.913 (a)

FCC Part 24E: 24.232 (c)

7.1.2 Test Limit

According to FCC Part 22.913 (a), the ERP of Cellular mobile transmitters must not exceed 7 Watts(38.5 dBm).

According to FCC Part 24.232 (c), the Mobile/portable stations are limited to 2 Watts(33 dBm) EIRP peak power.

Cellular Band		PCS Band	
GSM 850	UMTS Band V	PCS 1900	UMTS Band II
38.5 dBm (ERP)		33 dBm (EIRP)	

7.2 Test Setup

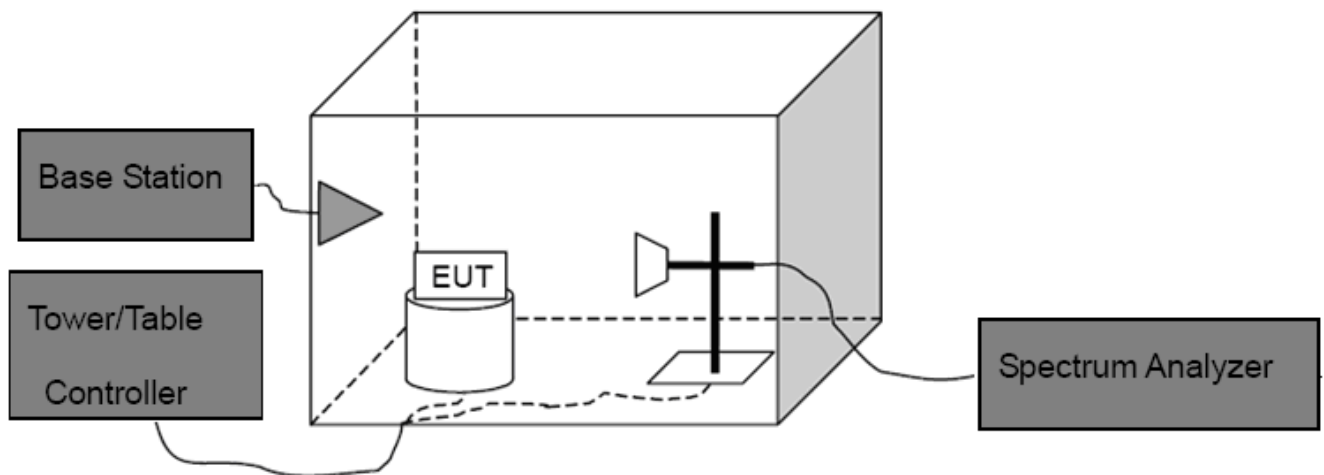

Above 1G

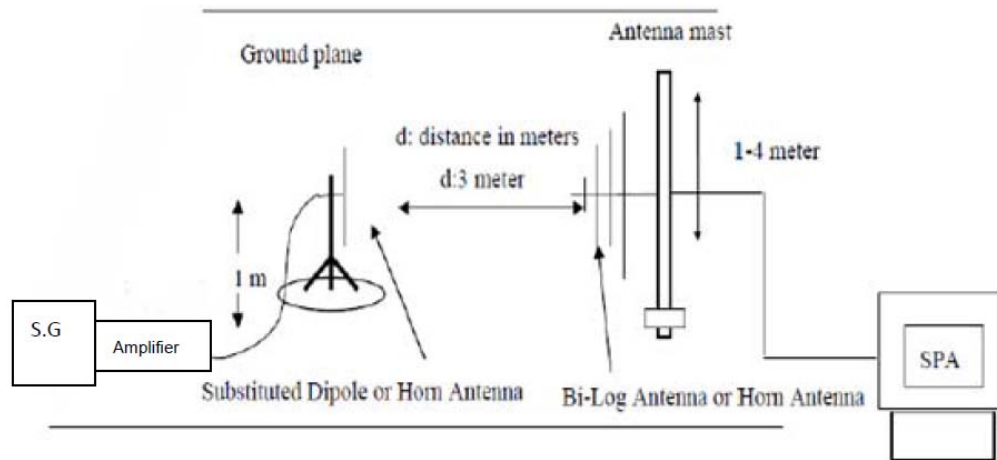

Substituted Method

7.3 Test Procedure

- (1) The EUT was placed on a non-conductive rotating platform with 0.8 meter height in an anechoic chamber. The radiated emission at the fundamental frequency was measured at 3 m with a test antenna and a spectrum analyzer with RBW=3 MHz, VBW=3 MHz and peak detector settings.
- (2) During the measurement, the EUT was enforced in maximum power and linked with the Base Station. The highest was recorded from analyzer power level (LVT) from the 360 degrees rotation of the turntable and the test antenna raised and lowered over a range from 1 to 4 meters in both horizontally and vertically polarized orientations.
- (3) Effective Isotropic Radiated Power (EIRP) was measured by substitution method according to C63.26. The EUT was replaced by dipole antenna (for frequency below 1 GHz) or Horn antenna (for frequency above 1 GHz) at same location with same polarize of receiver antenna and then a known power of each measure frequency from S.G. was applied into the dipole antenna or Horn antenna through a TX cable, and then recorded the maximum Analyzer reading through raised and lowered the test antenna.

Note: In test, the S.G. Connect the Pre-amplifier (Sonoma 310N Pre-amplifier for frequency below 1 GHz, HP 8449B Pre-amplifier for frequency above 1 GHz)

Then the EUT's EIRP and ERP was calculated with the correction factor:

$$ERP = S.G. Level + Antenna Gain Cord. (dBd) - Cable Loss (dB)$$

$$EIRP = S.G. Level + Antenna Gain Cord. (dBi) - Cable Loss (dB)$$

7.4 EUT Operating Condition

The EUT was continuously connected with the Base station and transmitting in the max power during the test.

7.5 Test Data

Please refer to the Attachment D.

8. Occupied Bandwidth

8.1 Test Standard and Limit

8.1.1 Test Standard

FCC Part 2: 2.1049

FCC Part 22H : 22.913 (a)

FCC Part 24E: 24.232 (c)

8.1.2 Test Requirement

According to FCC section 2.1049, the occupied bandwidth is the frequency bandwidth such that below its lower and above its upper frequency limits, the mean powers radiated are each equal to 0.5 percent of the total mean power radiated by a given emission.

Occupied bandwidth is also known as 99% power and -26dBC occupied bandwidths.

8.2 Test Setup

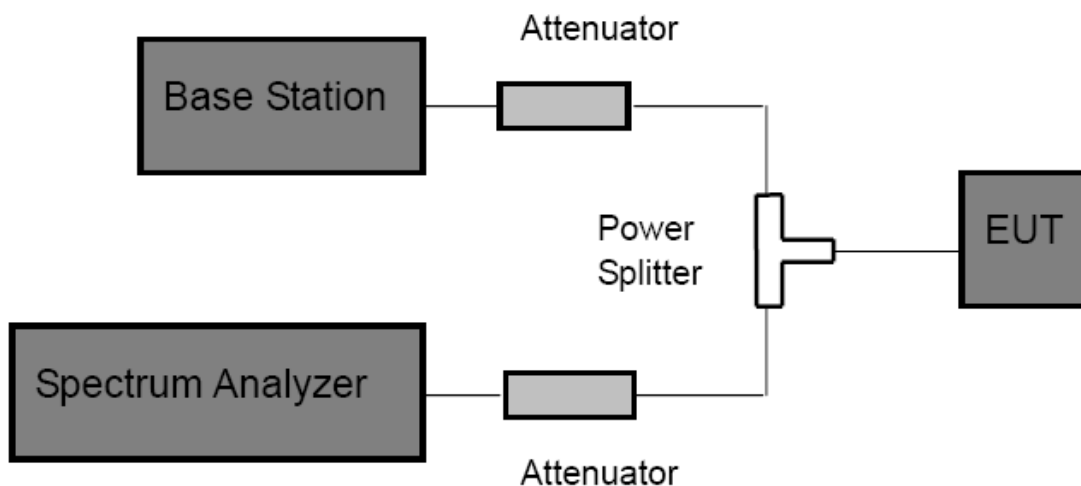

8.3 Test Procedure

- (1) The EUT was directly connected to the spectrum analyzer and Base station via power splitter as show in the block diagram above.
- (2) The resolution bandwidth of the Spectrum Analyzer is set to at least 1% of the occupied bandwidth.
- (3) The low, middle and the high channels are selected to perform tests respectively.
- (4) Set the frequency range of the Spectrum Analyzer suitably to capture the waveform; search peak; make a line whose value is 26dB lower than the peak; mark two points which the line intersected the waveform at; finally record the delta of the two points as the occupied bandwidth and the plot.
- (5) Set the Spectrum Analyzer Occupied bandwidth function to measure the 99% occupied bandwidth.

8.4 EUT Operating Condition

The EUT was continuously connected with the Base station and transmitting in the max power during the test.

8.5 Test Data

Please refer to the Attachment E.

9. Conducted Out of Band Emissions

9.1 Test Standard and Limit

9.1.1 Test Standard

FCC Part 2: 2.1051, 2.1057

FCC Part 22H: 22.917(a)

FCC Part 24E: 24.238(a)

9.1.2 Test Limit

The power of any emission outside of the authorized operating frequency ranges must be attenuated below the transmitting power(P) by a factor of at least $43+10\log(P)$ dB. For all power levels +30 dBm to 0 dBm, this becomes a constant specification limit of -13 dBm.

9.2 Test Setup

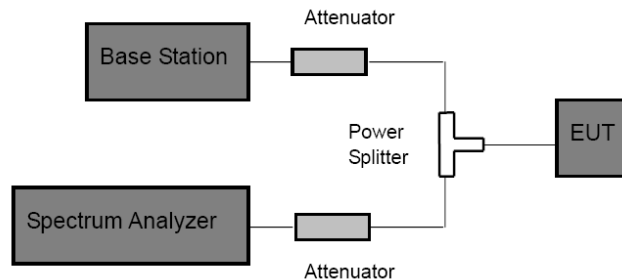

9.3 Test Procedure

- (1) The EUT was directly connected to the spectrum analyzer and Base station via power splitter as show in the block diagram above.
- (2) Spectrum Setting:
Frequency bellow 1 GHz: RBW=100 kHz, VBW=300 kHz.
Frequency above 1 GHz: RBW=1 MHz, VBW=3 MHz.
- (3) The low, middle and high channels of each band and mode's spurious emissions for 30 MHz to 10th Harmonic were measured by Spectrum analyzer.

9.4 EUT Operating Condition

The EUT was continuously connected with the Base station and transmitting in the max power during the test.

9.5 Test Data

Please refer to the Attachment F.

10. Band Edge Test

10.1 Test Standard and Limit

10.1.1 Test Standard

FCC Part 2: 2.1051, 2.1057

FCC Part 22H: 22.917(a)

FCC Part 24E: 24.238(a)

10.1.2 Test Limit

The power of any emission outside of the authorized operating frequency ranges must be attenuated below the transmitting power(P) by a factor of at least $43+10\log(P)$ dB. For all power levels +30 dBm to 0 dBm, this becomes a constant specification limit of -13 dBm.

10.2 Test Setup

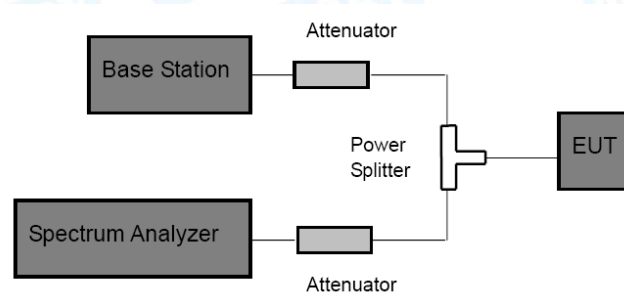

10.3 Test Procedure

(1) The EUT was directly connected to the spectrum analyzer and Base station via power splitter as show in the block diagram above.

(2) Spectrum Setting:

GSM and PCS: $RBW \geq 1\%$ 26db bandwidth, $VBW=3$ RBW, Span 1 MHz, Detector: Peak Mode.

WCDMA: $RBW \geq 1\%$ 26db bandwidth, $VBW=3$ RBW, Span 10 MHz, Detector: Peak Mode.

(3) The band edges of low and high channels for the highest RF powers were measured.

10.4 EUT Operating Condition

The EUT was continuously connected with the Base station and transmitting in the max power during the test.

10.5 Test Data

Please refer to the Attachment G.

11. Radiated Out Band of Emissions

11.1 Test Standard and Limit

11.1.1 Test Standard

FCC Part 2: 2.1053, 2.1057

FCC Part 22H: 22.917

FCC Part 24E: 24.238

11.1.2 Test Limit

The power of any emission outside of the authorized operating frequency ranges must be attenuated below the transmitting power(P) by a factor of at least $43+10\log(P)$ dB. For all power levels +30 dBm to 0 dBm, this becomes a constant specification limit of -13 dBm.

11.2 Test Setup

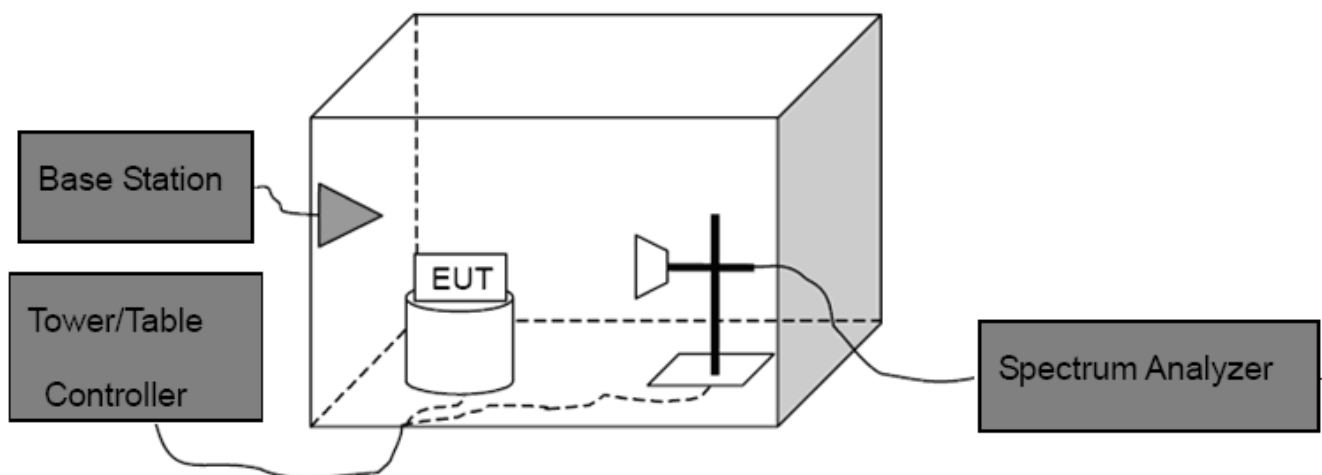

11.3 Test Procedure

- (1) The test system setup as show in the block diagram above.
- (2) The EUT was placed on an non-conductive rotating platform in an anechoic chamber. The radiated spurious emissions from 30MHz to 10^{th} harmonious of fundamental frequency were measured at 3 m with a test antenna and a spectrum analyzer with RBW=1 MHz, VBW=1 MHz, peak detector settings.
- (3) During the measurement, the EUT was enforced in maximum power and linked with a base station. All the spurious emissions at 3m were measured by rotation of the turntable and the test antenna raised and lowered over a range from 1 to 4 meters in both horizontally and vertically polarized orientations.
- (4) When found the maximum level of emissions from the EUT. Remove the EUT and replace it with substitution antenna. A signal generator was connected to the substitution antenna by a non-radiating cable. The absolute levels of the spurious emissions were measured by the substitution.

Spurious emissions in dB=10 log(TX power in Watts/0.001)-the absolute level
Spurious attenuation limit in dB=43+10 log(power out in Watts)

11.4 EUT Operating Condition

The EUT was continuously connected with the Base station and transmitting in the max power during the test.

11.5 Test Data

Please refer to the Attachment H.

Attachment A--Frequency Stability

Temperature Variation

Temperature Variation UMTS Band V (CH 4183)		
Temperature (°C)	HSDPA Mode	
	Freq. Dev. (Hz)	Deviation (ppm)
-30	13	0.016
-20	13	0.016
-10	12	0.014
0	13	0.016
10	14	0.017
20	16	0.019
30	14	0.017
40	14	0.017
50	12	0.014
60	18	0.022
Limit	2.5 (ppm)	
Result	PASS	

Temperature Variation UMTS Band II (CH 9400)		
Temperature (°C)	HSDPA Mode	
	Freq. Dev. (Hz)	Deviation (ppm)
-30	10	0.005
-20	12	0.006
-10	18	0.010
0	11	0.006
10	15	0.008
20	13	0.007
30	10	0.005
40	15	0.008
50	12	0.006
60	11	0.006
Limit	2.5 (ppm)	
Result	PASS	

Voltage Variation

Voltage Variation UMTS Band V (CH 4182)		
Voltage (V)	HSDPA Mode	
	Freq. Dev. (Hz)	Deviation (ppm)
3.15	20	0.024
3.70	17	0.020
4.26	19	0.023
Limit	2.5 (ppm)	
Result	PASS	

Voltage Variation UMTS Band II (CH 9400)		
Voltage (V)	HSDPA Mode	
	Freq. Dev. (Hz)	Deviation (ppm)
3.15	17	0.009
3.70	19	0.010
4.26	18	0.010
Limit	2.5 (ppm)	
Result	PASS	

Attachment B--Conducted RF Output Power

UMTS Band V				
Mode	Channel	Frequency (MHz)	Conducted Power (dBm)	Conducted Power (W)
Band V RMC	4132	826.4	20.98	0.125
	4183	836.6	21.64	0.146
	4233	846.6	21.09	0.129
HSDPA Subtest 1	4132	826.4	22.09	0.162
	4183	836.6	22.04	0.160
	4233	846.6	22.13	0.163
HSDPA Subtest 2	4132	826.4	21.36	0.137
	4183	836.6	21.35	0.136
	4233	846.6	21.54	0.143
HSDPA Subtest 3	4132	826.4	20.56	0.114
	4183	836.6	20.74	0.119
	4233	846.6	20.63	0.116
HSDPA Subtest 4	4132	826.4	20.18	0.104
	4183	836.6	20.22	0.105
	4233	846.6	20.32	0.108
HSUPA Subtest 1	4132	826.4	21.99	0.158
	4183	836.6	22.02	0.159
	4233	846.6	22.04	0.160
HSUPA Subtest 2	4132	826.4	21.68	0.147
	4183	836.6	21.75	0.150
	4233	846.6	21.59	0.144
HSUPA Subtest 3	4132	826.4	20.65	0.116
	4183	836.6	20.56	0.114
	4233	846.6	20.63	0.116
HSUPA Subtest 4	4132	826.4	20.24	0.106
	4183	836.6	20.21	0.105
	4233	846.6	20.18	0.104
HSUPA Subtest 5	4132	826.4	19.69	0.093
	4183	836.6	19.85	0.097
	4233	846.6	19.58	0.091

UMTS Band II				
Mode	Channel	Frequency (MHz)	Conducted Power (dBm)	Conducted Power (W)
Band II RMC	9262	1852.4	21.37	0.137
	9400	1880.0	20.84	0.121
	9538	1907.6	20.94	0.124
HSDPA Subtest 1	9262	1852.4	22.35	0.172
	9400	1880.0	21.93	0.156
	9538	1907.6	21.89	0.155
HSDPA Subtest 2	9262	1852.4	21.34	0.136
	9400	1880.0	21.26	0.134
	9538	1907.6	21.27	0.134
HSDPA Subtest 3	9262	1852.4	20.65	0.116
	9400	1880.0	20.58	0.114
	9538	1907.6	20.67	0.117
HSDPA Subtest 4	9262	1852.4	20.46	0.111
	9400	1880.0	20.36	0.109
	9538	1907.6	20.52	0.113
HSUPA Subtest 1	9262	1852.4	22.27	0.169
	9400	1880.0	21.96	0.157
	9538	1907.6	21.80	0.151
HSUPA Subtest 2	9262	1852.4	21.58	0.144
	9400	1880.0	21.65	0.146
	9538	1907.6	21.62	0.145
HSUPA Subtest 3	9262	1852.4	21.13	0.130
	9400	1880.0	21.09	0.129
	9538	1907.6	21.14	0.130
HSUPA Subtest 4	9262	1852.4	20.65	0.116
	9400	1880.0	20.33	0.108
	9538	1907.6	20.42	0.110
HSUPA Subtest 5	9262	1852.4	20.13	0.103
	9400	1880.0	20.27	0.106
	9538	1907.6	20.46	0.111

Attachment C--Peak-Average Ratio

UMTS Band II			
Mode	Channel	Frequency (MHz)	Peak-Average Ratio (PAR)
UMTS Band II	9262	1852.4	4.18
	9400	1880.0	4.00
	9538	1907.6	4.30
			Limit ≤ 13dB

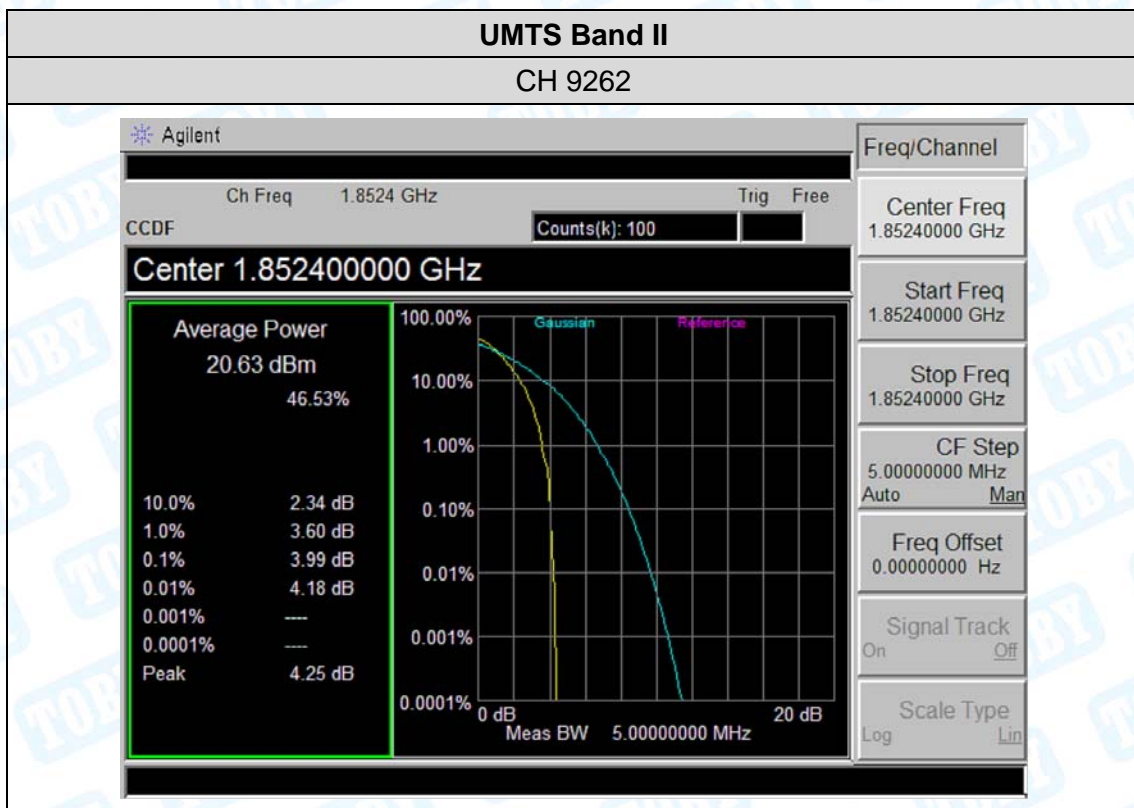

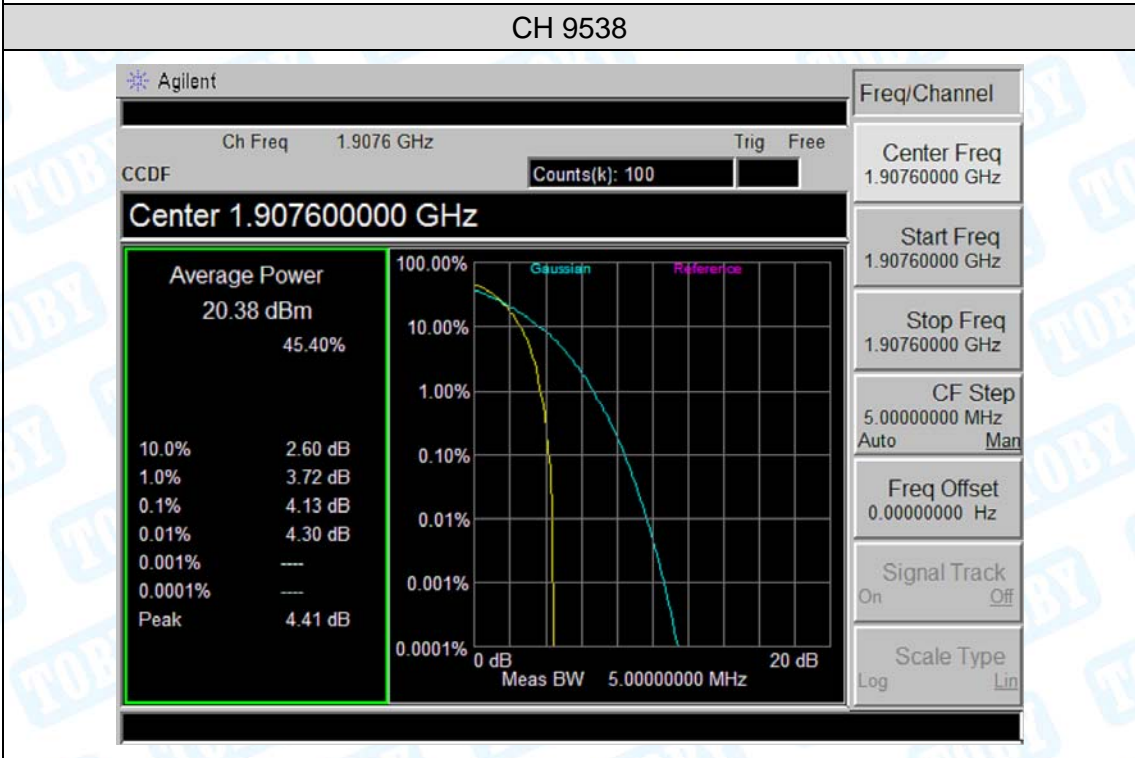
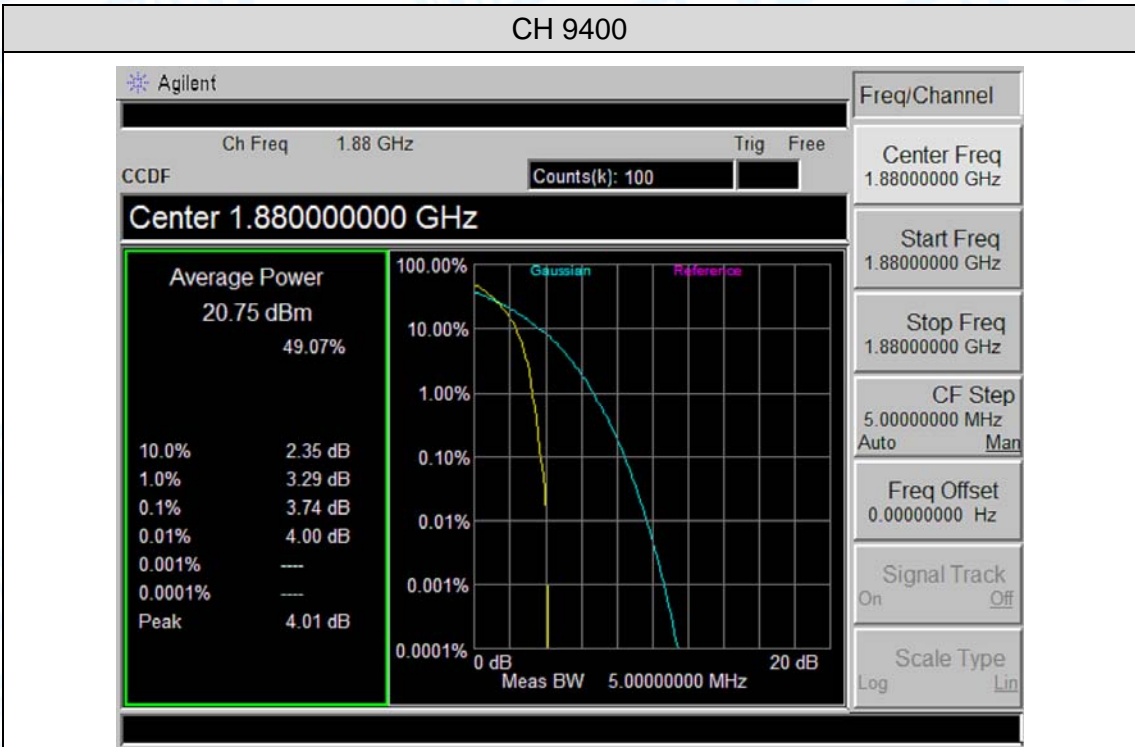

Attachment D-- Radiated Output Power

Measurement Data (worst case)

UMTS Band V								
Mode	Channel	Frequency (MHz)	Antenna (H&V)	SG Level (dBm)	Antenna Factor (dBi)	Cable Loss (dB)	ERP Power (dBm)	ERP Power (W)
Band V HSDPA	4132	826.4	H	18.82	3.46	1.26	21.02	0.127
			V	16.43	3.46	1.26	18.63	0.073
	4183	836.6	H	18.67	3.82	1.26	21.23	0.133
			V	16.09	3.82	1.26	18.65	0.073
	4233	846.6	H	18.08	4.16	1.26	20.98	0.125
			V	15.21	4.16	1.26	18.11	0.065
Limit							38.5	7

UMTS Band II								
Mode	Channel	Frequency (MHz)	Antenna (H&V)	SG Level (dBm)	Antenna Factor (dBi)	Cable Loss (dB)	EIRP Power (dBm)	EIRP Power (W)
Band II HSDPA	9262	1852.4	H	18.56	5.01	2.59	20.98	0.125
			V	15.13	5.01	2.59	17.55	0.057
	9400	1880.0	H	18.66	4.82	2.59	20.89	0.123
			V	15.76	4.82	2.59	17.99	0.063
	9538	1907.6	H	19.39	4.45	2.59	21.25	0.133
			V	16.55	4.45	2.59	18.41	0.069
Limit							33	2

Attachment E--Occupied Bandwidth

UMTS Band V				
Mode	Channel	Frequency (MHz)	99% OBW (MHz)	-26dB Bandwidth (MHz)
Band V HSDPA	4132	826.4	4.2335	4.863
	4183	836.6	4.2121	4.866
	4233	846.6	4.2391	4.904
Band V HSUPA	4132	826.4	4.2364	4.866
	4183	836.6	4.2260	4.904
	4233	846.6	4.2319	4.904
UMTS Band II				
Mode	Channel	Frequency (MHz)	99% OBW (MHz)	-26dB Bandwidth (MHz)
Band II HSDPA	9262	1852.4	4.2474	4.895
	9400	1880.0	4.2088	4.869
	9538	1907.6	4.1987	4.889
Band II HSUPA	9262	1852.4	4.2335	4.892
	9400	1880.0	4.2135	4.828
	9538	1907.6	4.2168	4.858

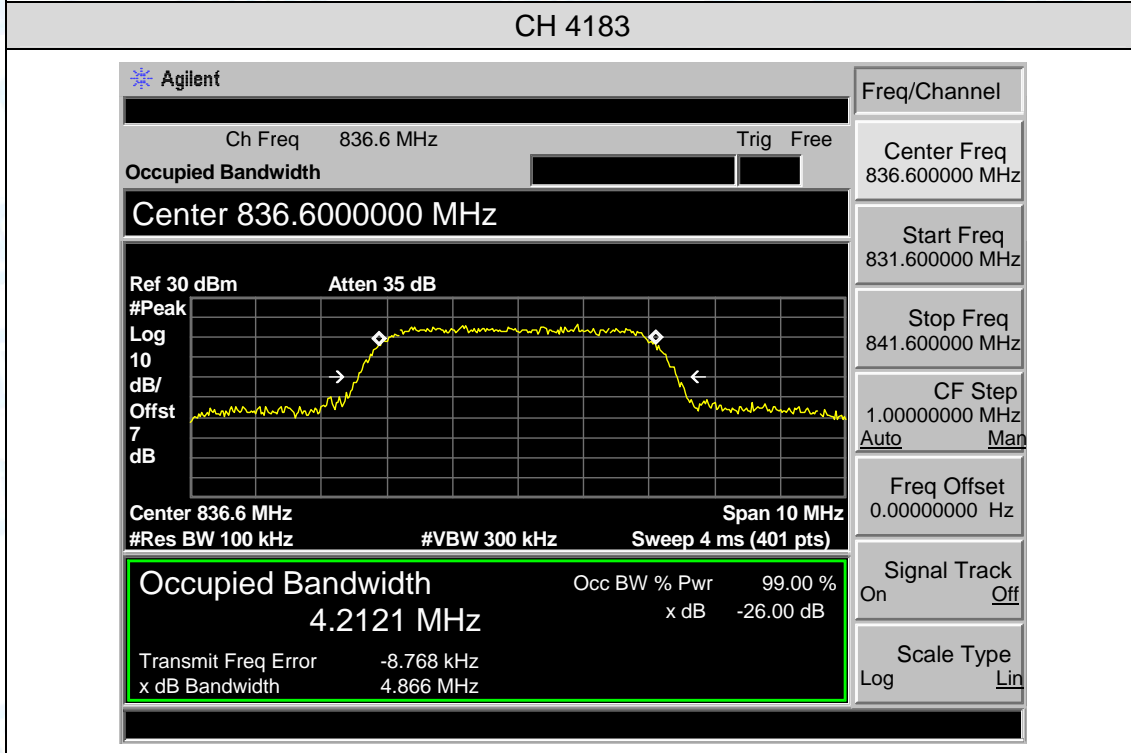
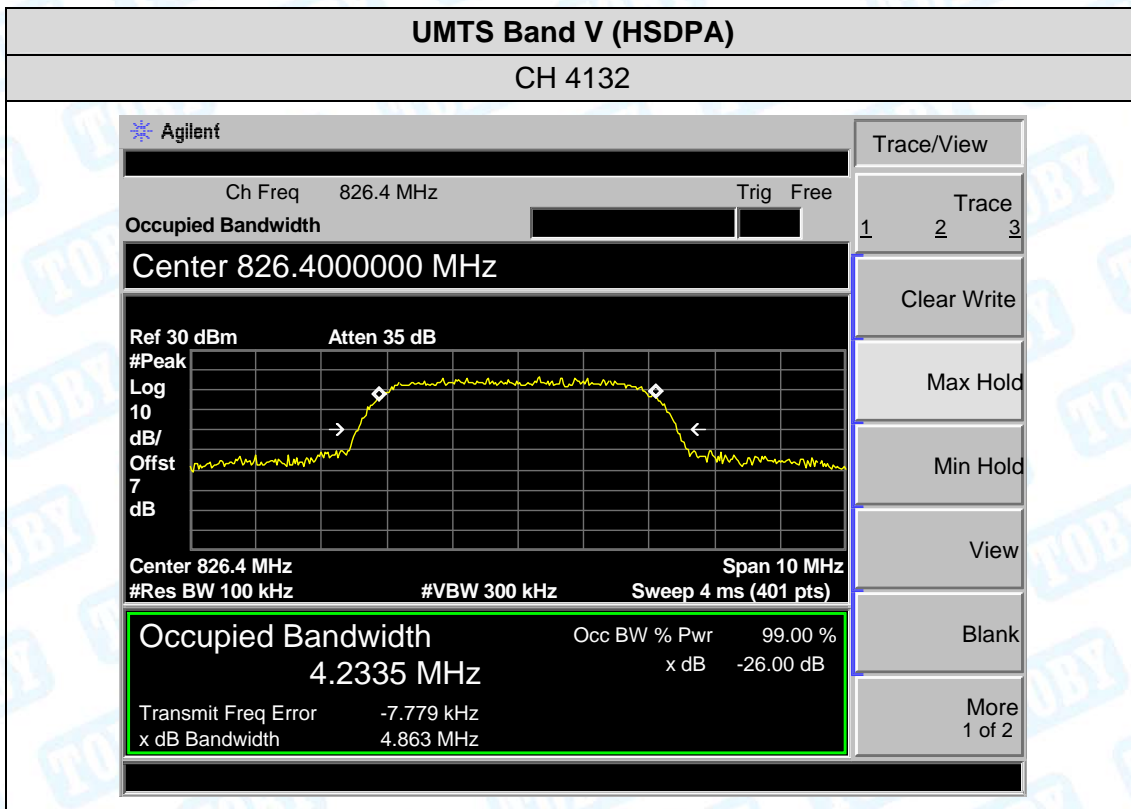

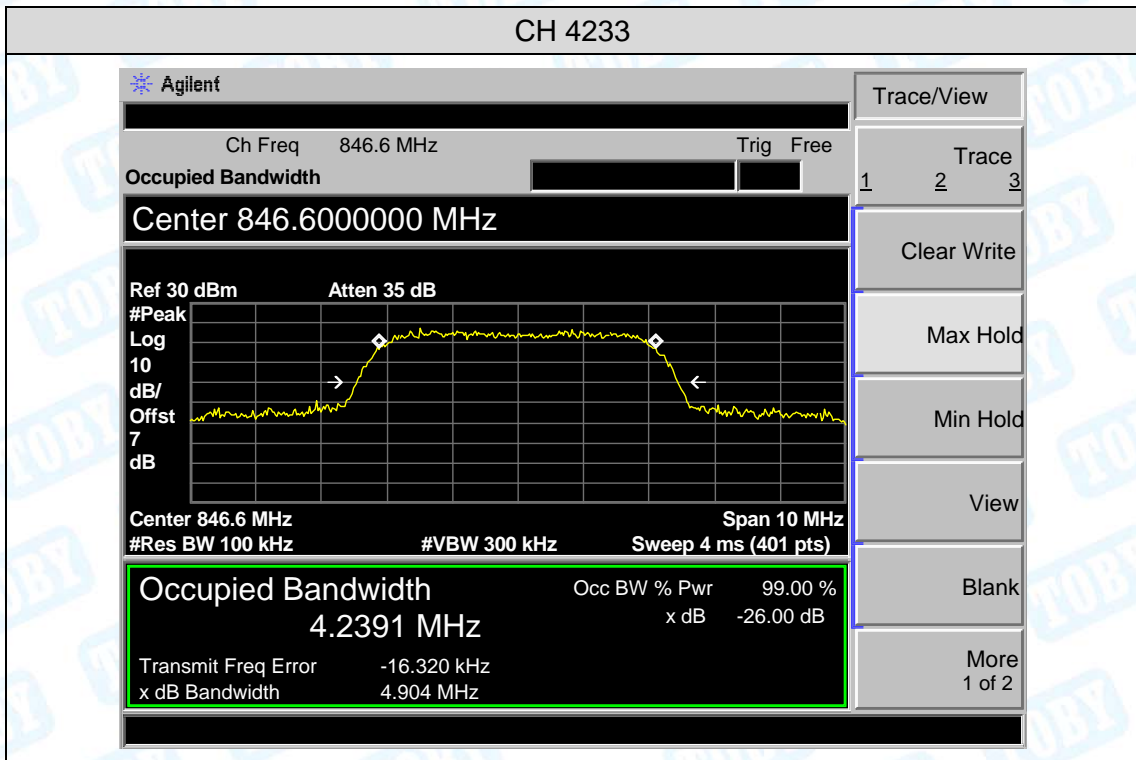

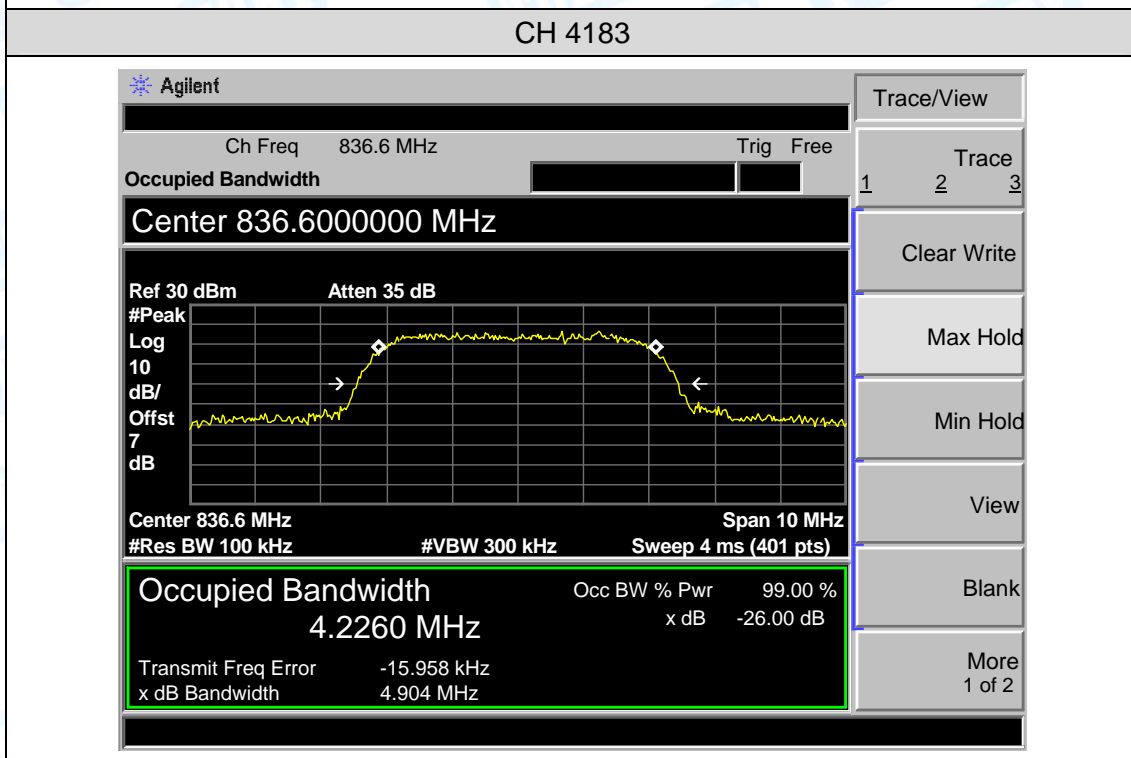
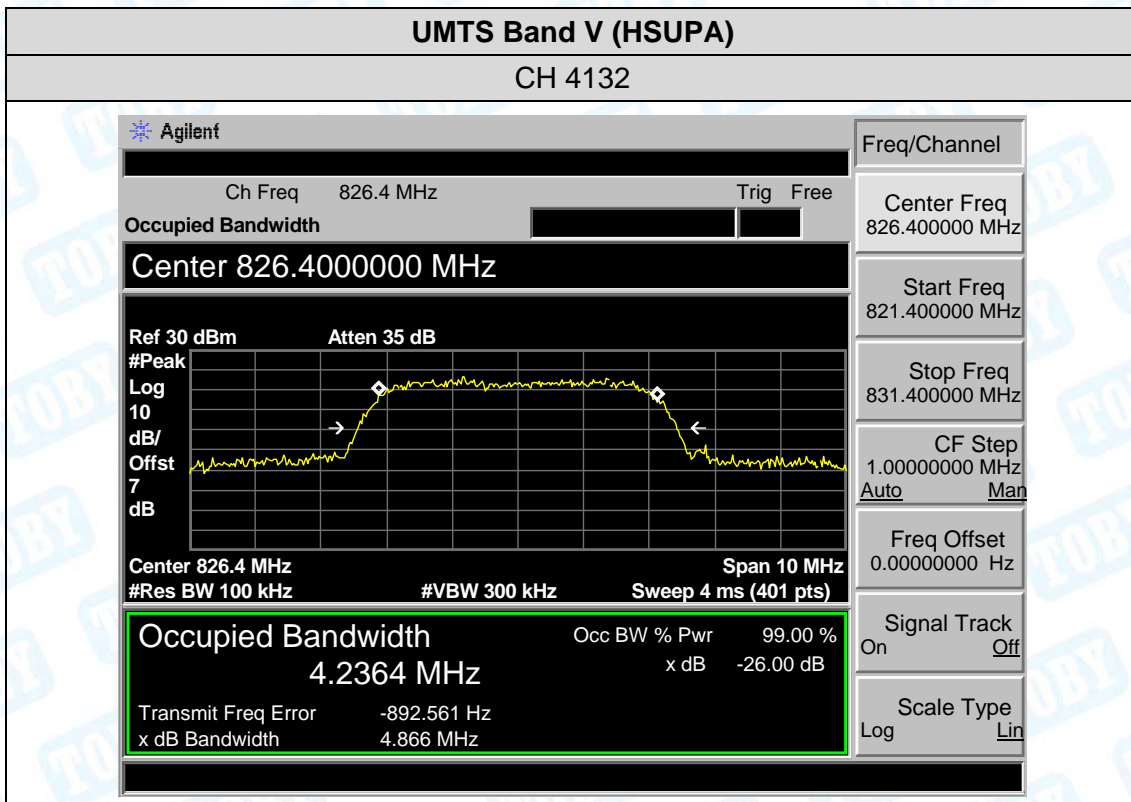

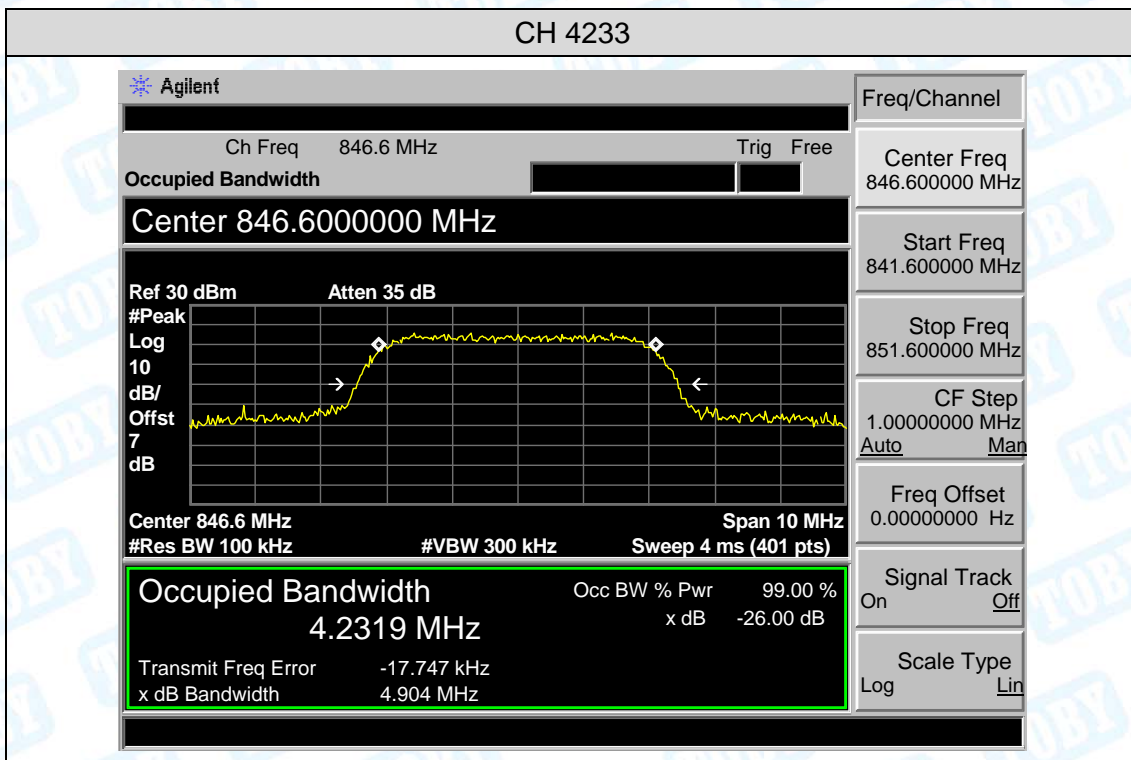

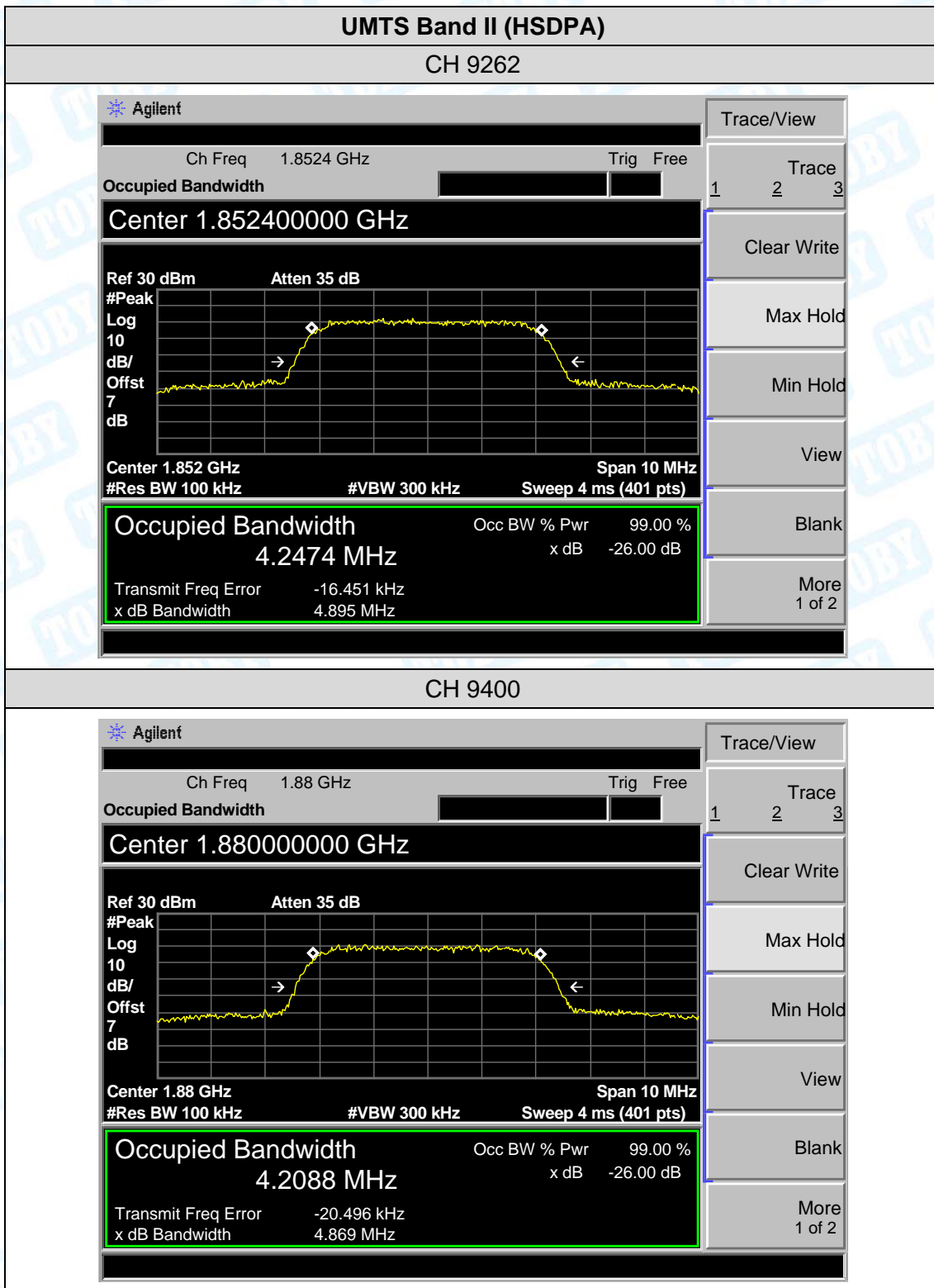

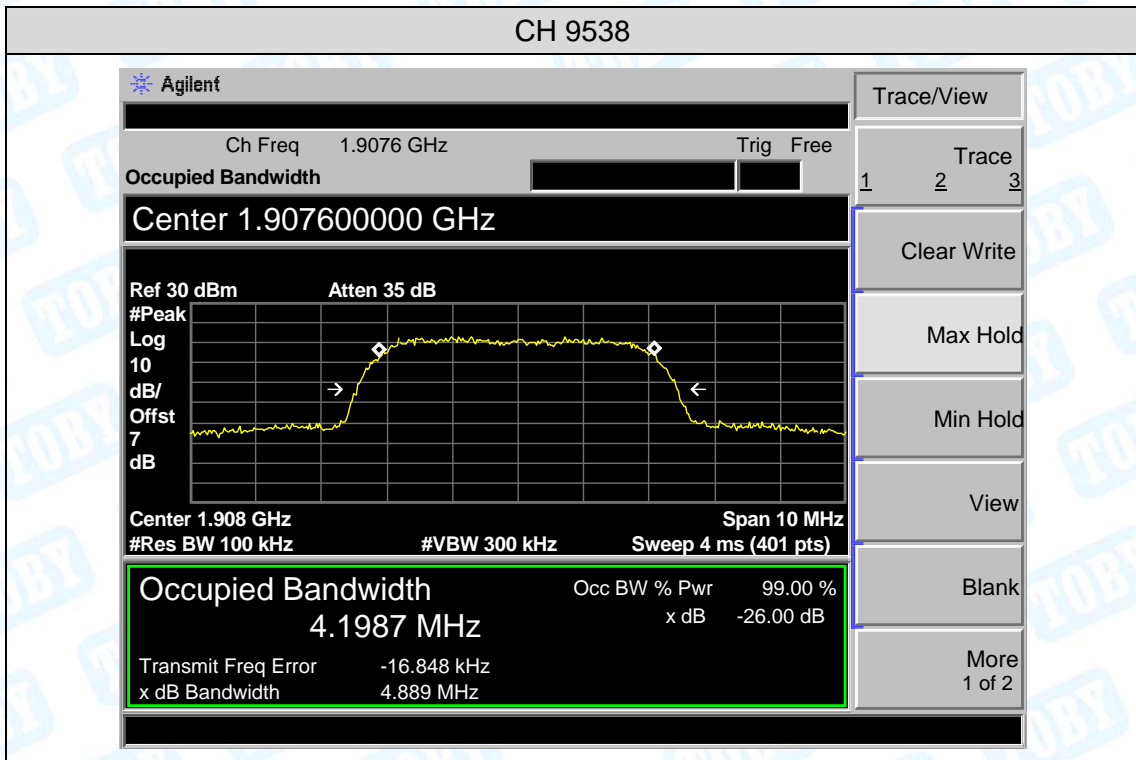

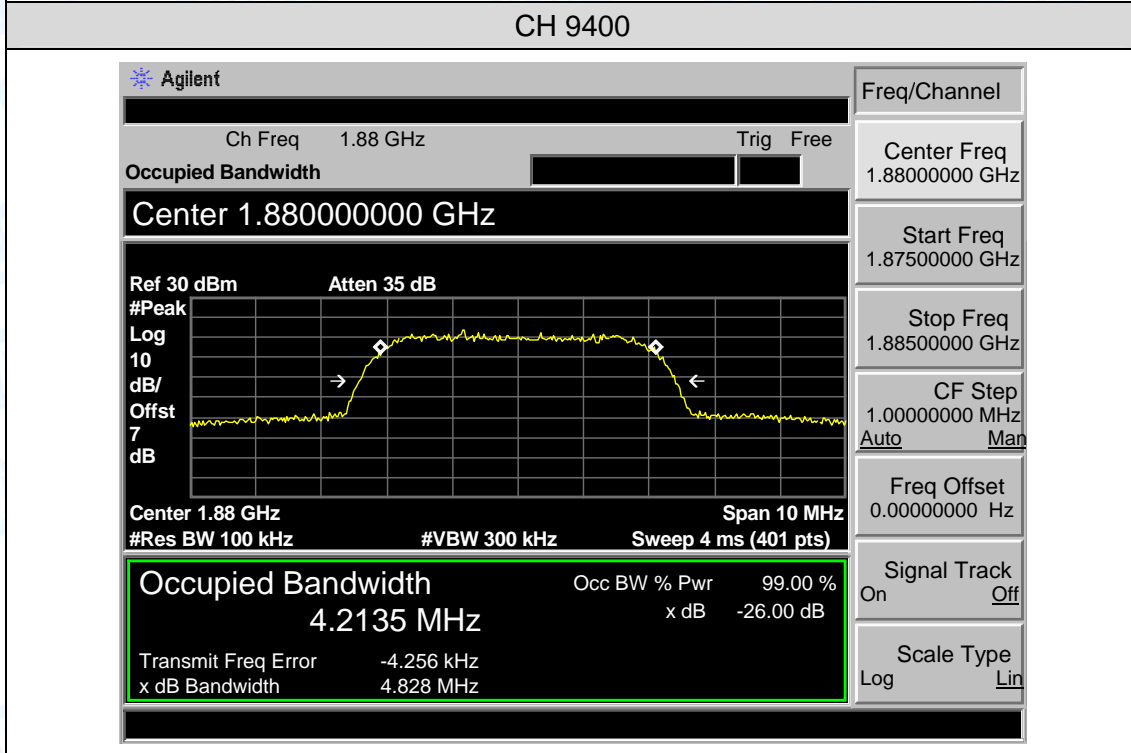
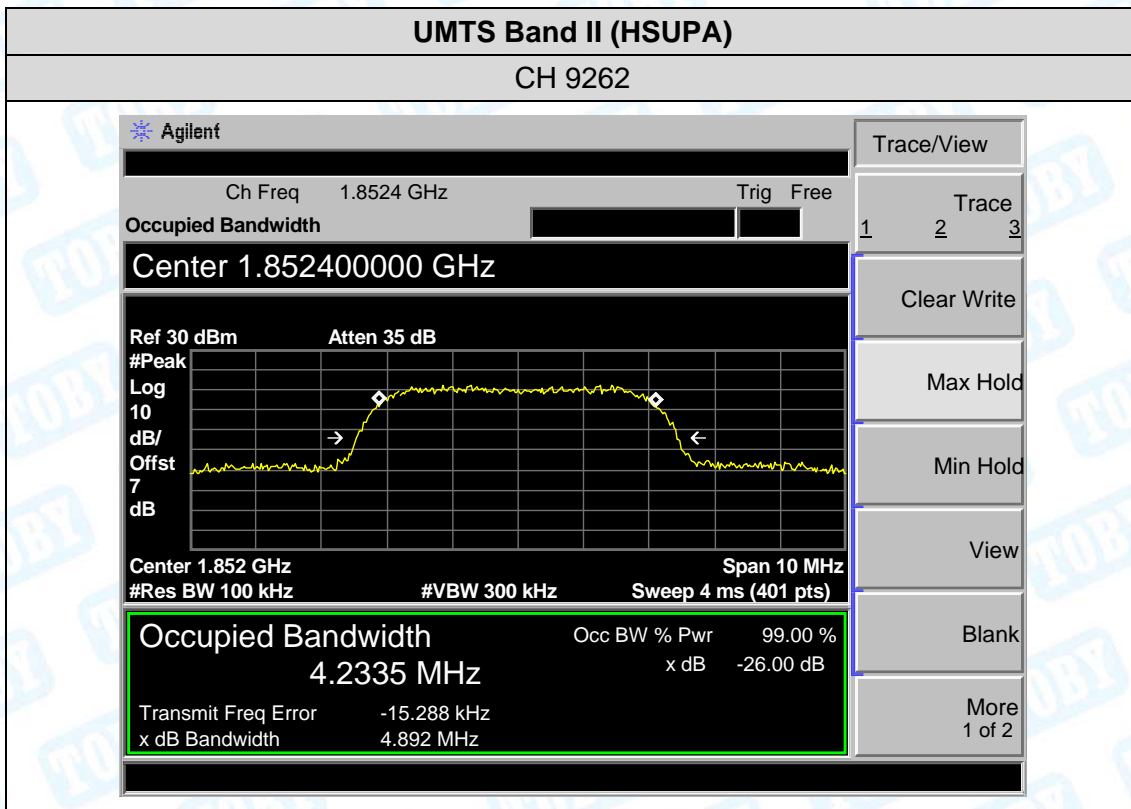

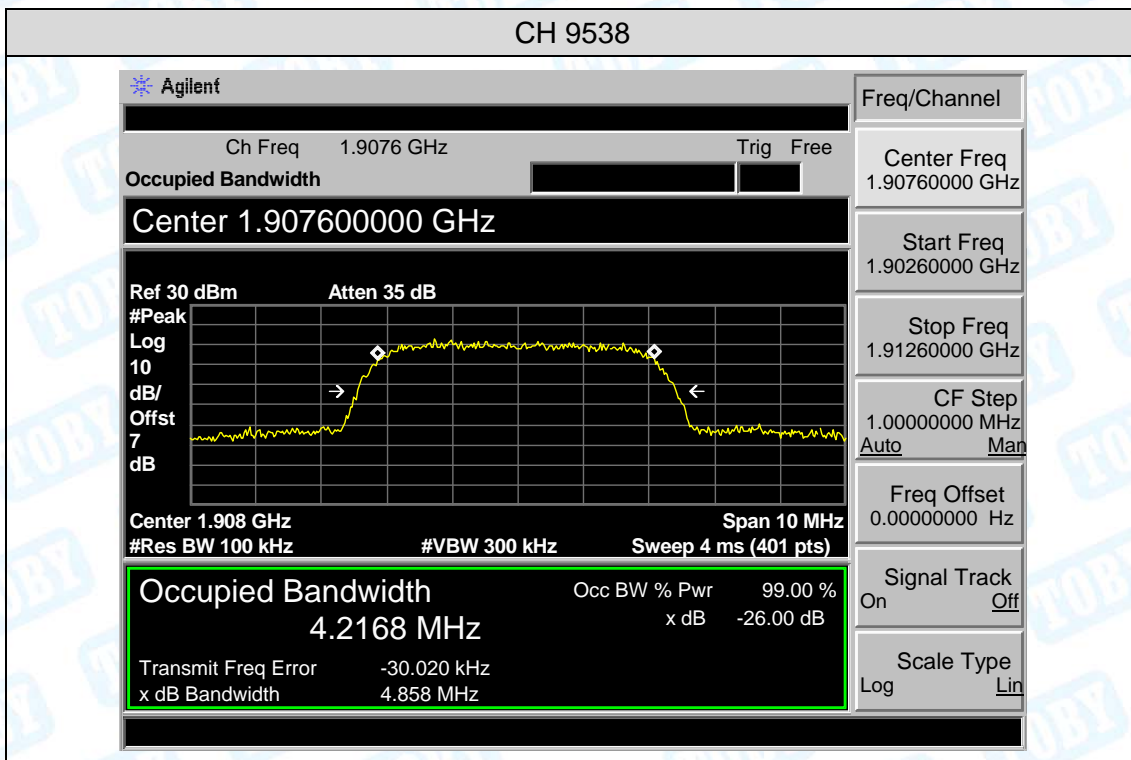

Attachment F--Conducted Out of Band Emissions

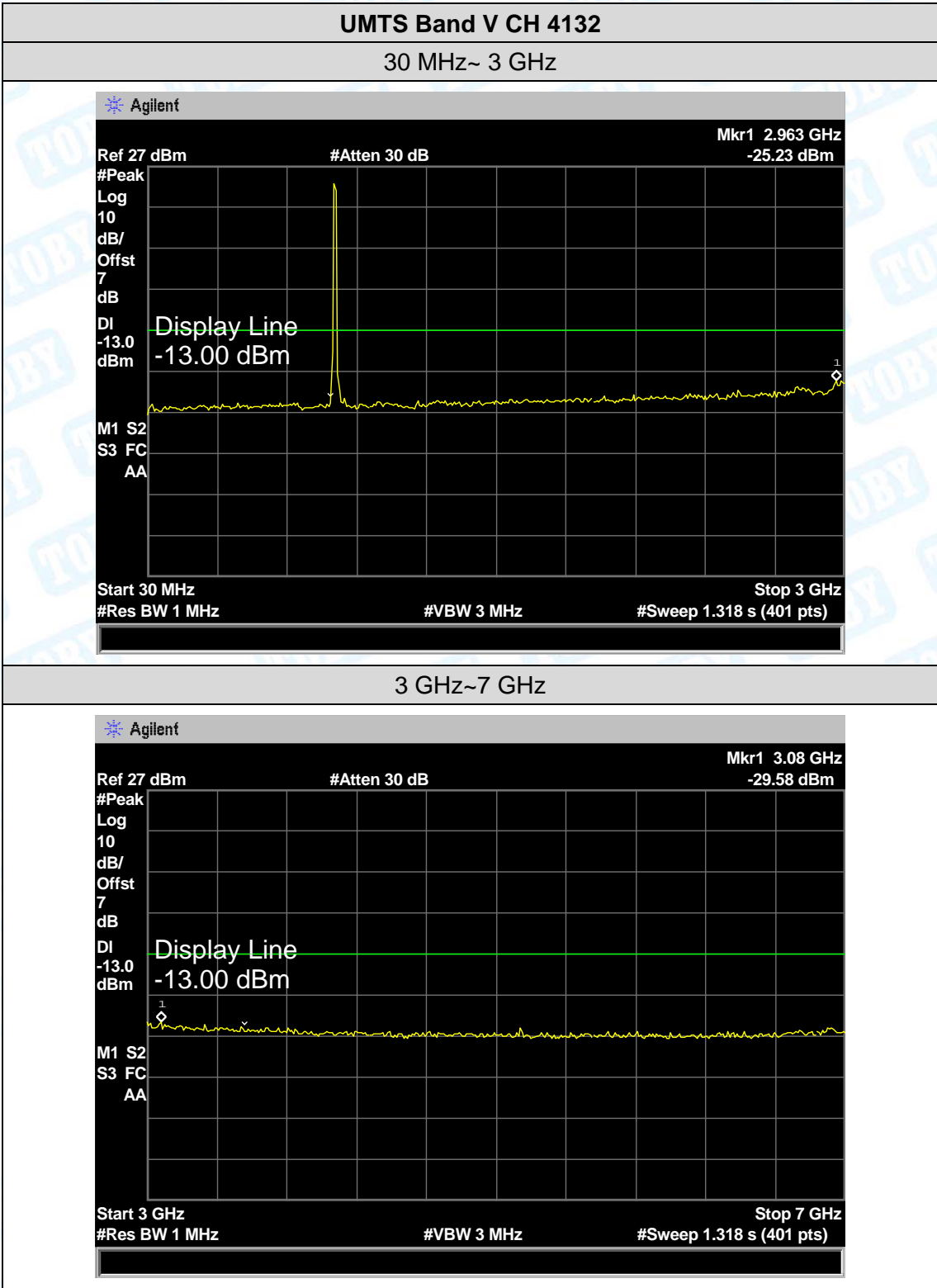

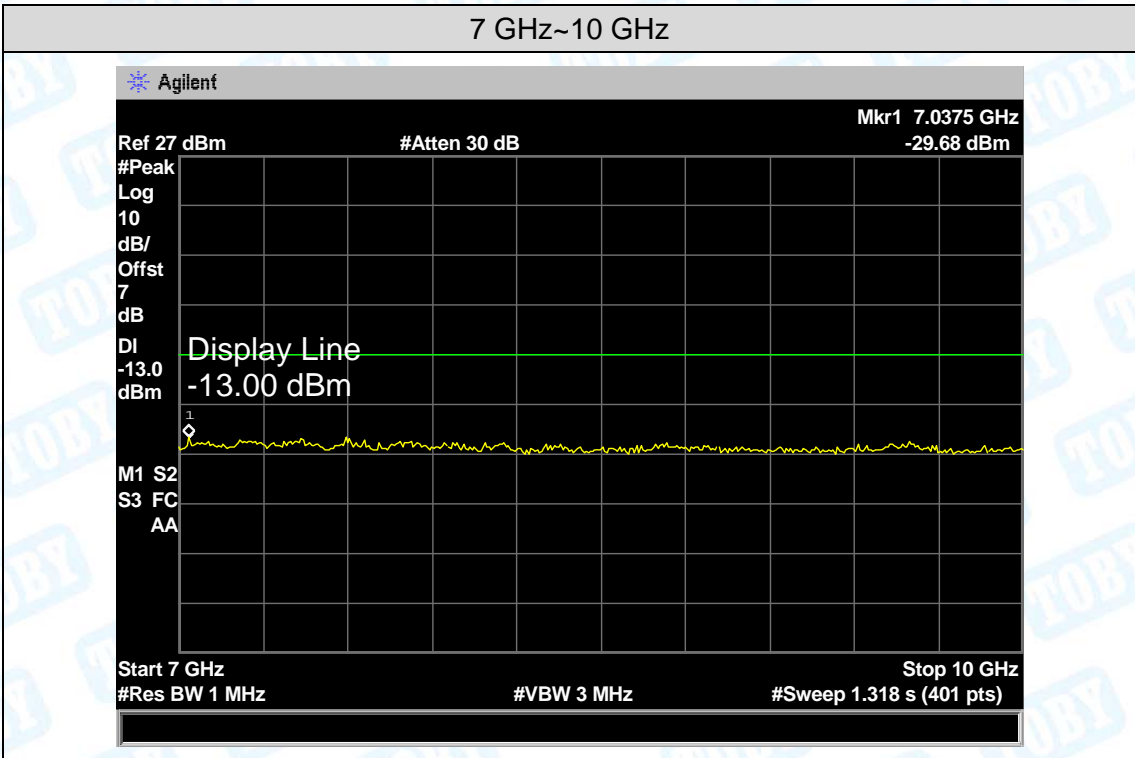

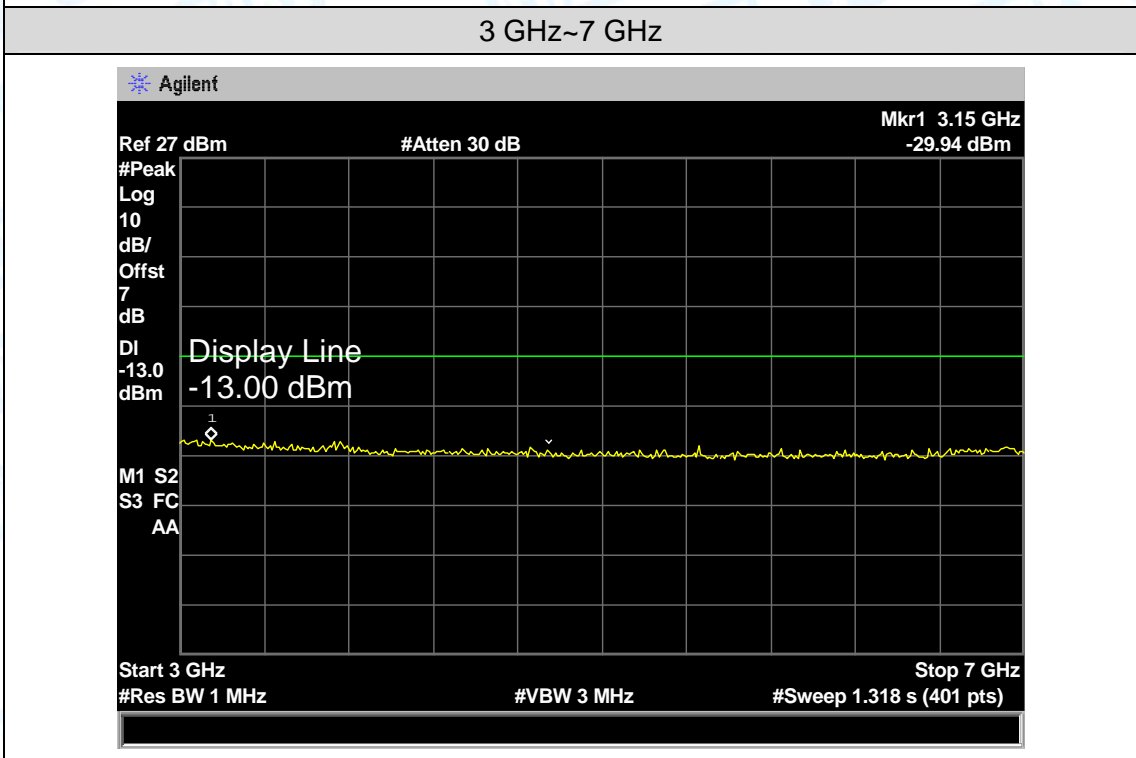
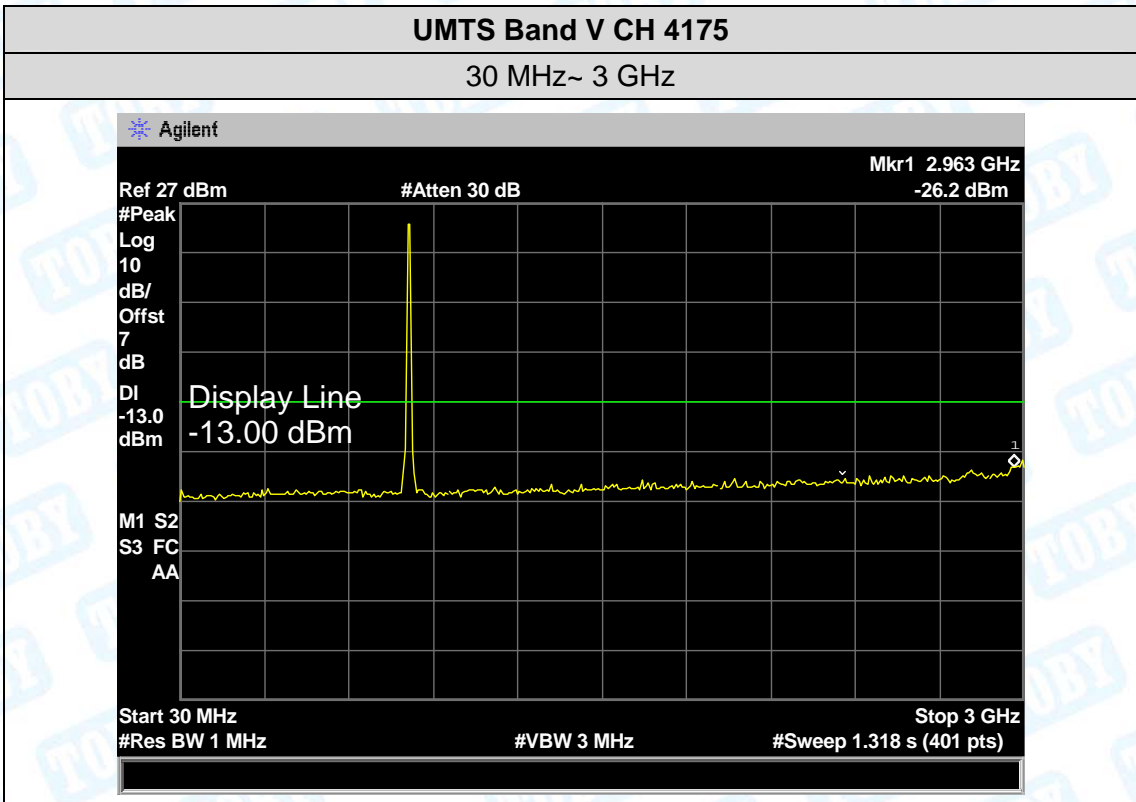

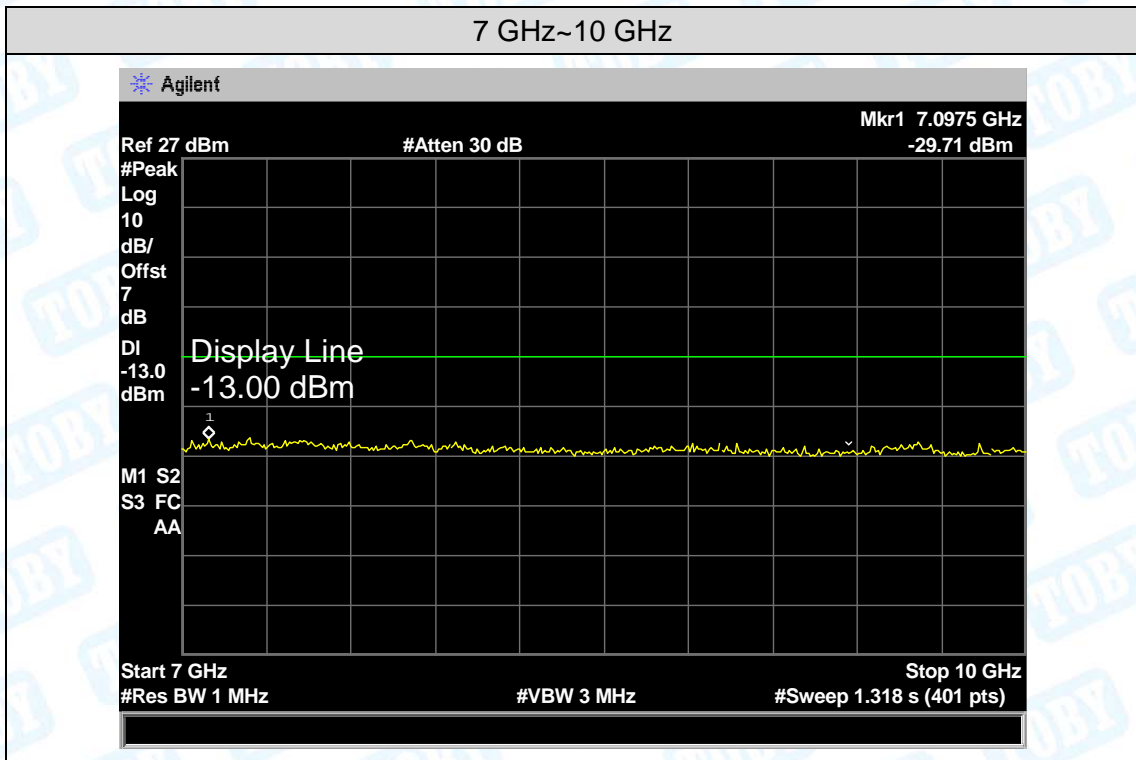

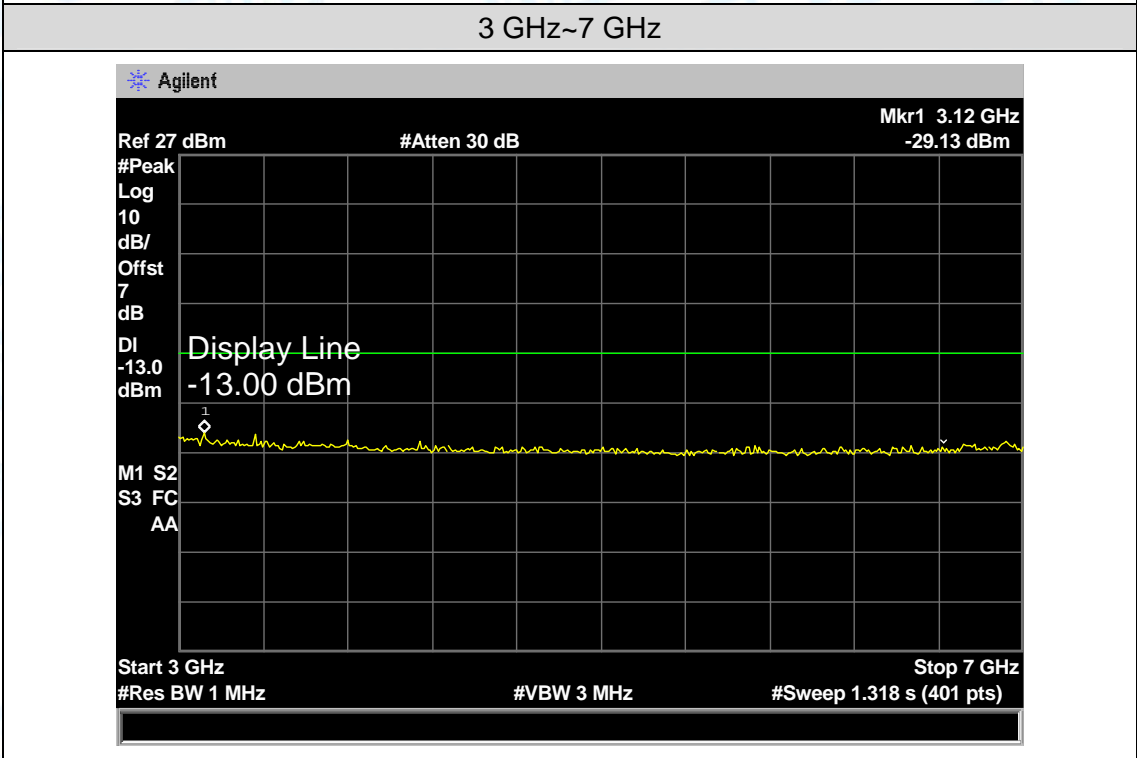
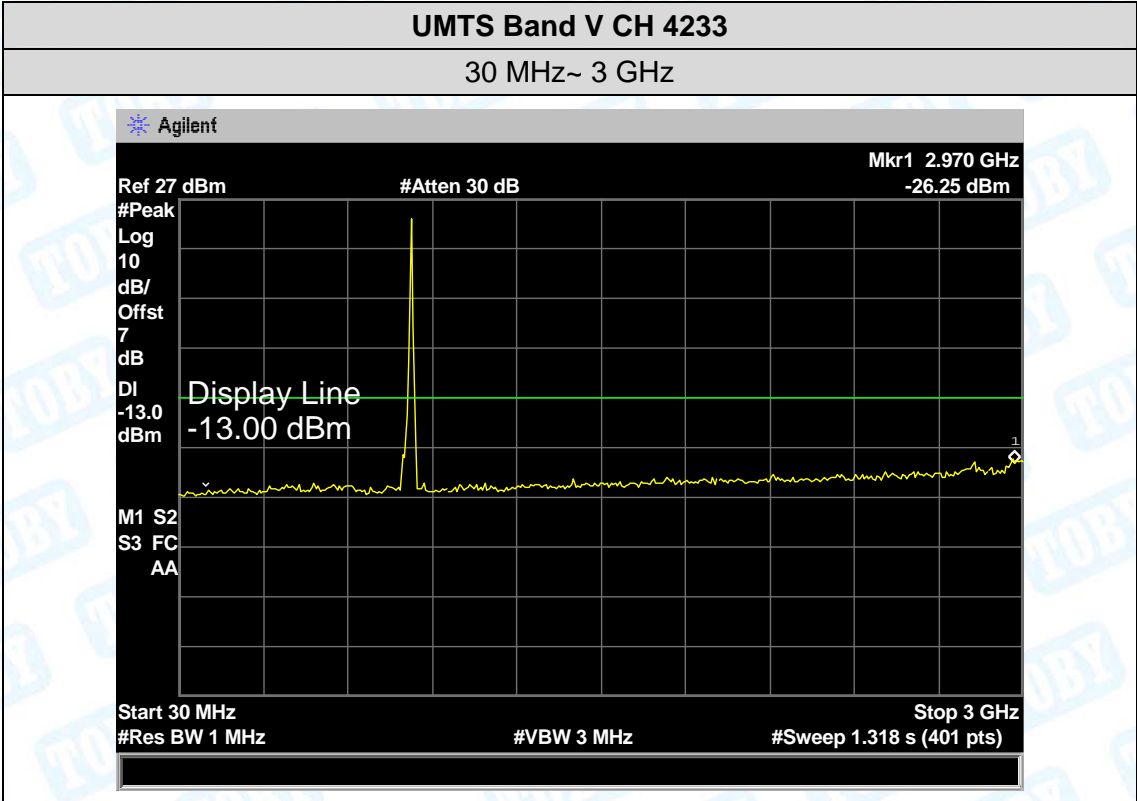

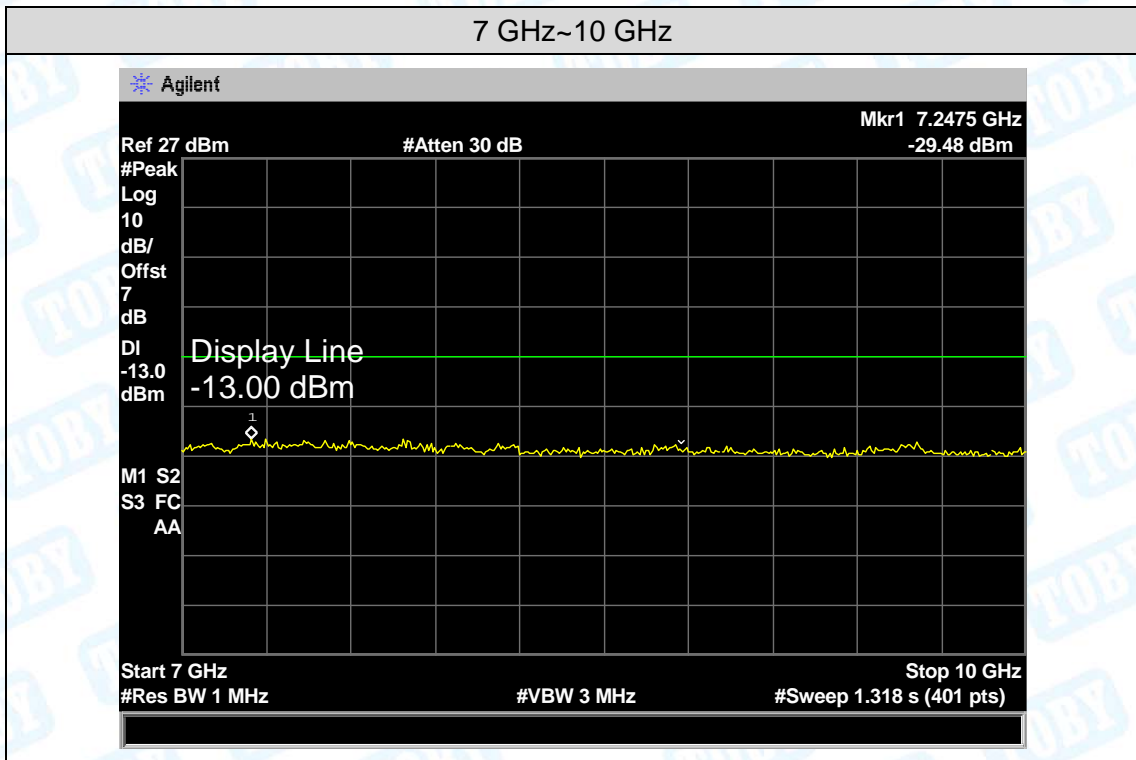

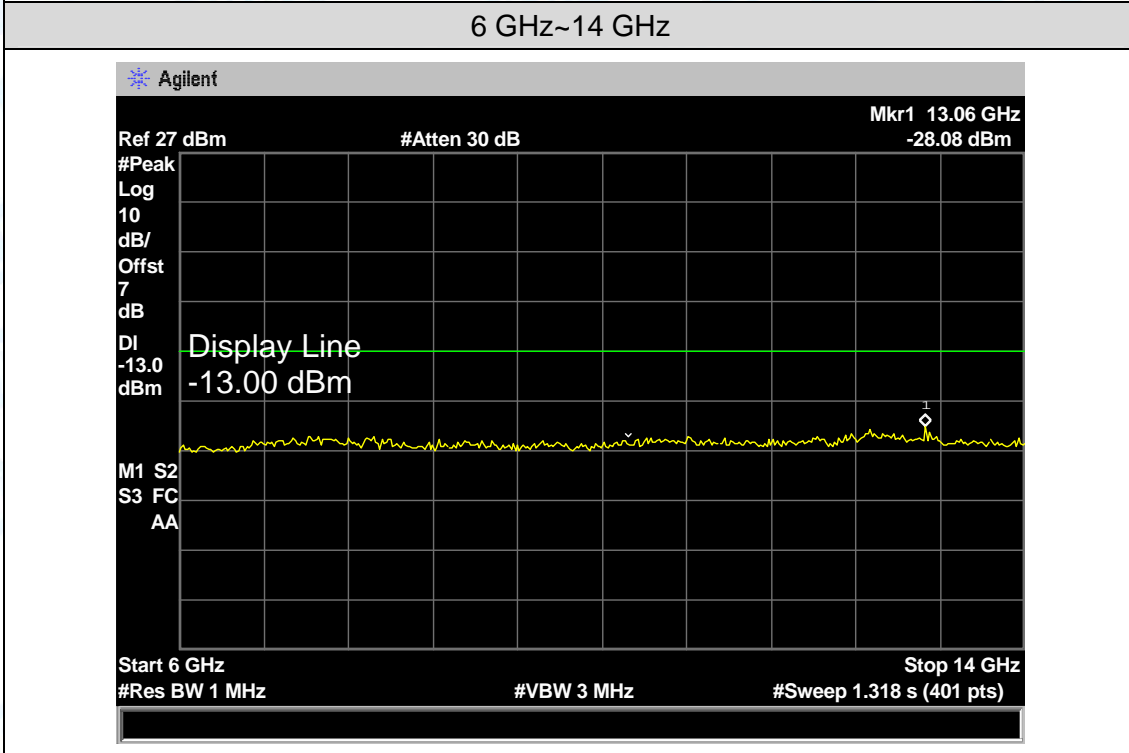
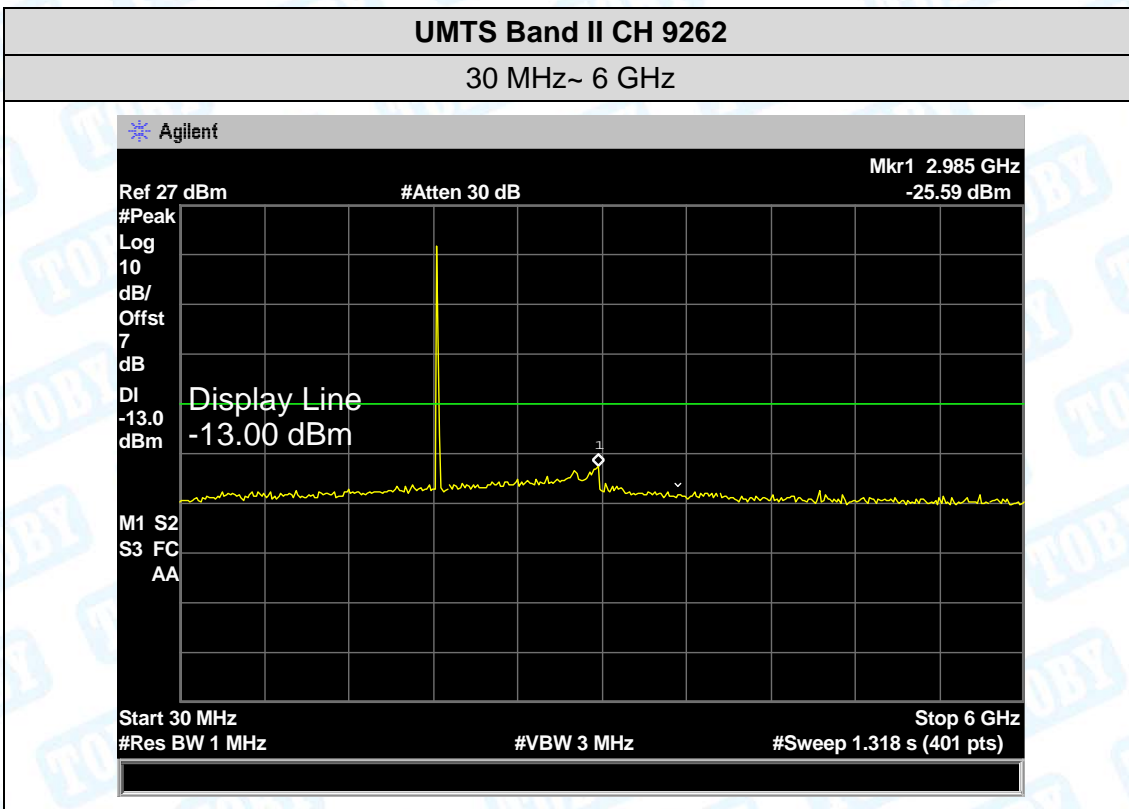

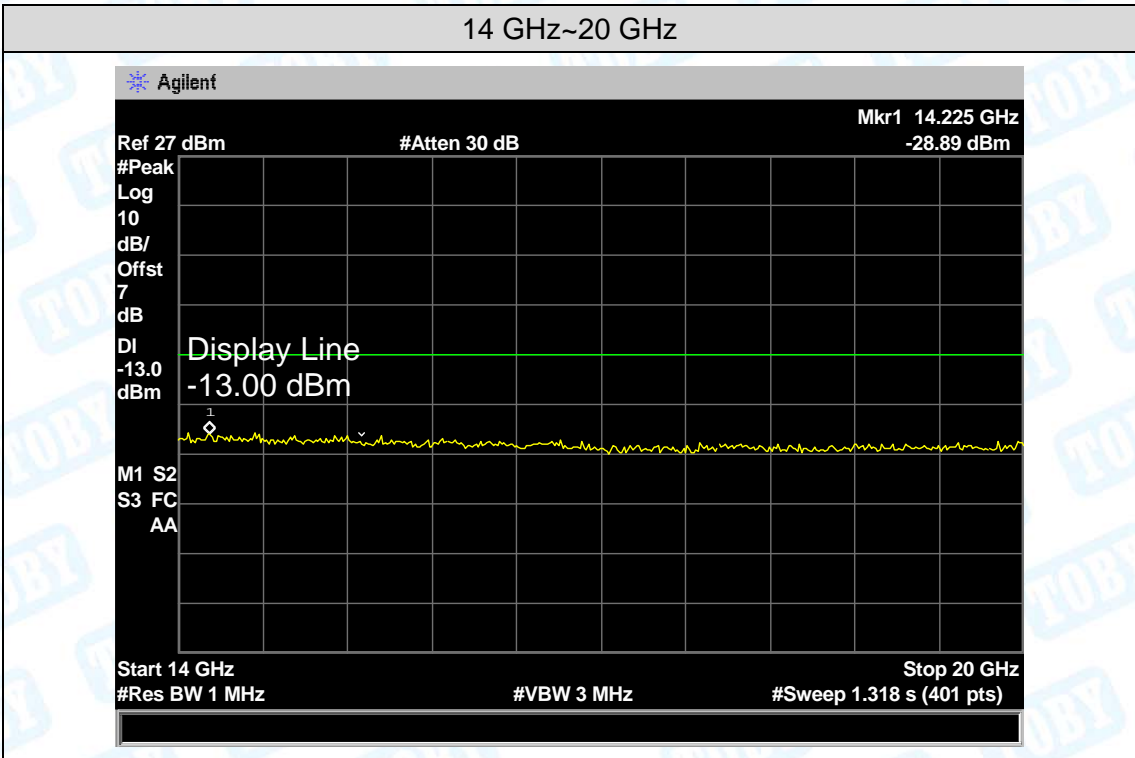

UMTS Band II CH 9400

30 MHz~ 6 GHz

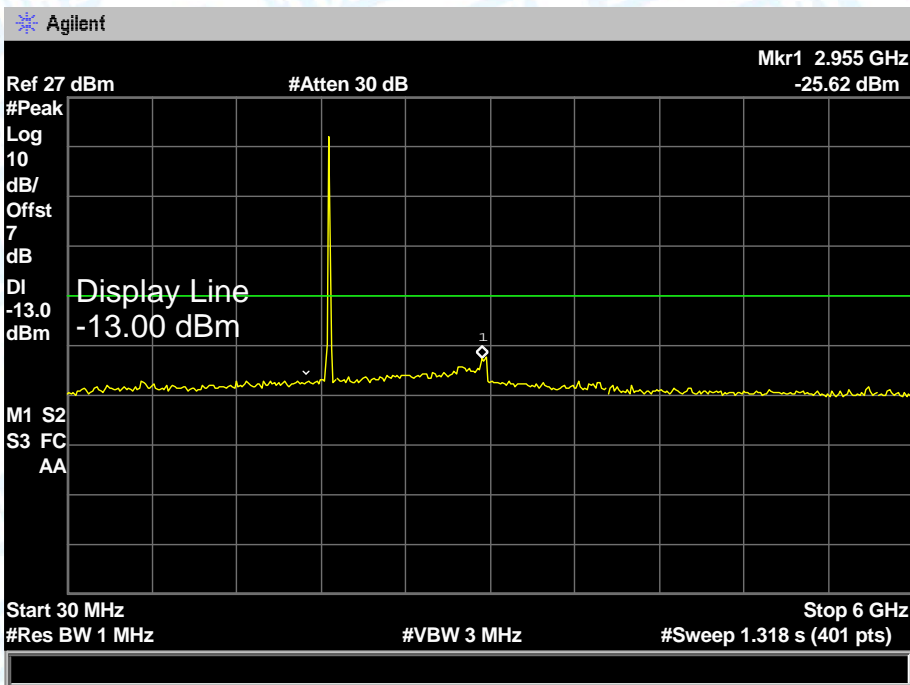

6 GHz~14 GHz

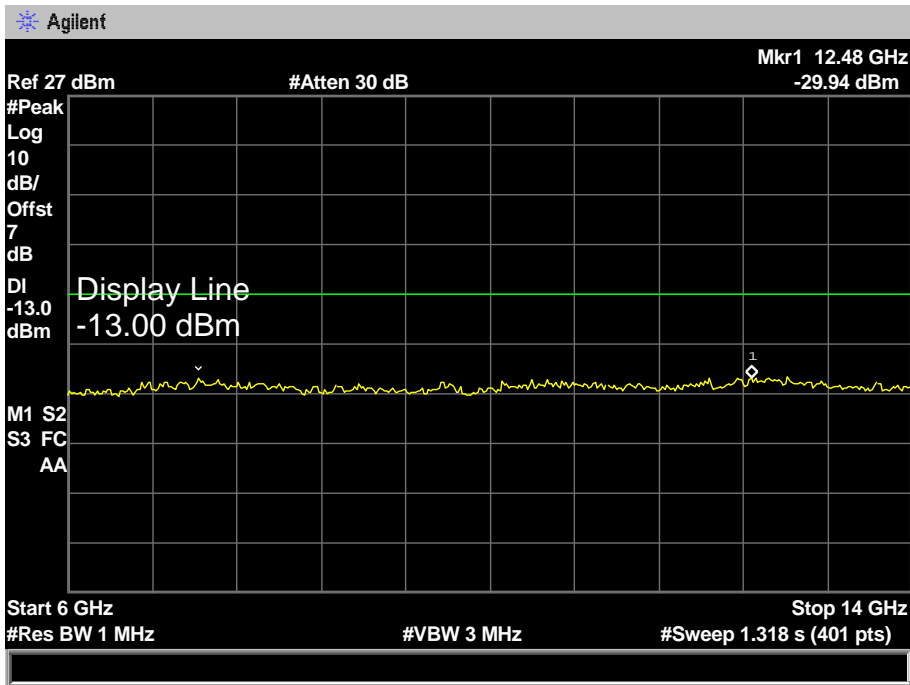

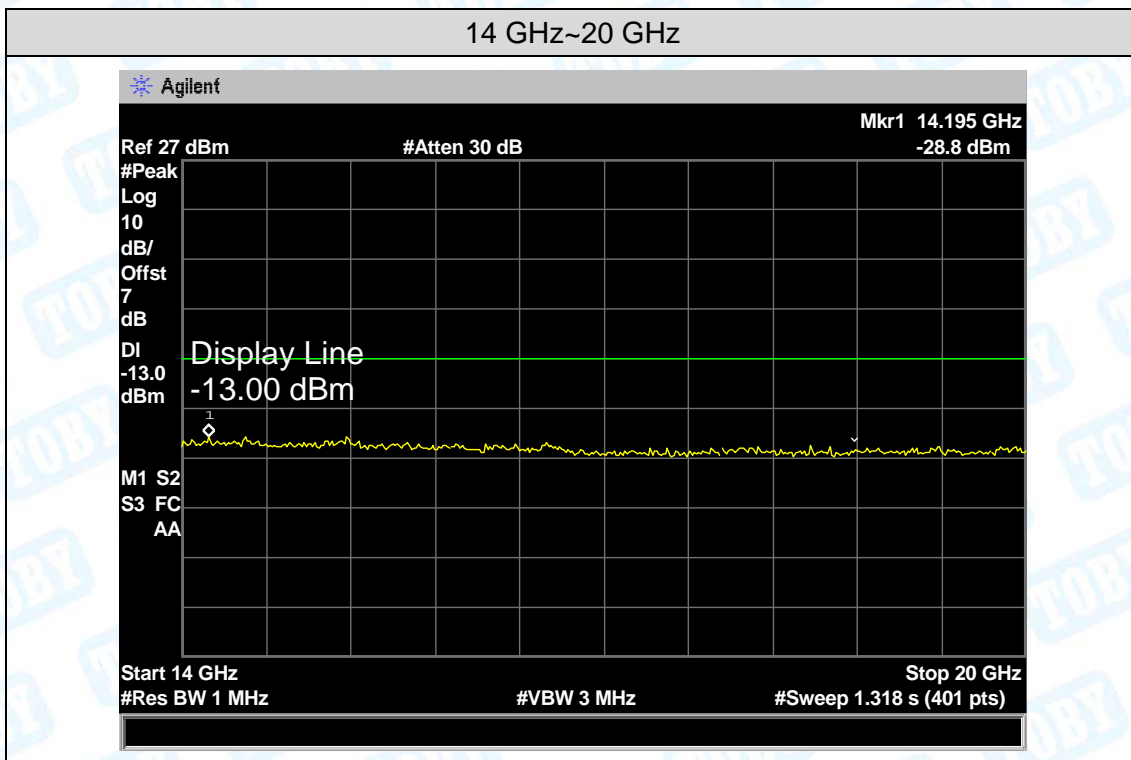

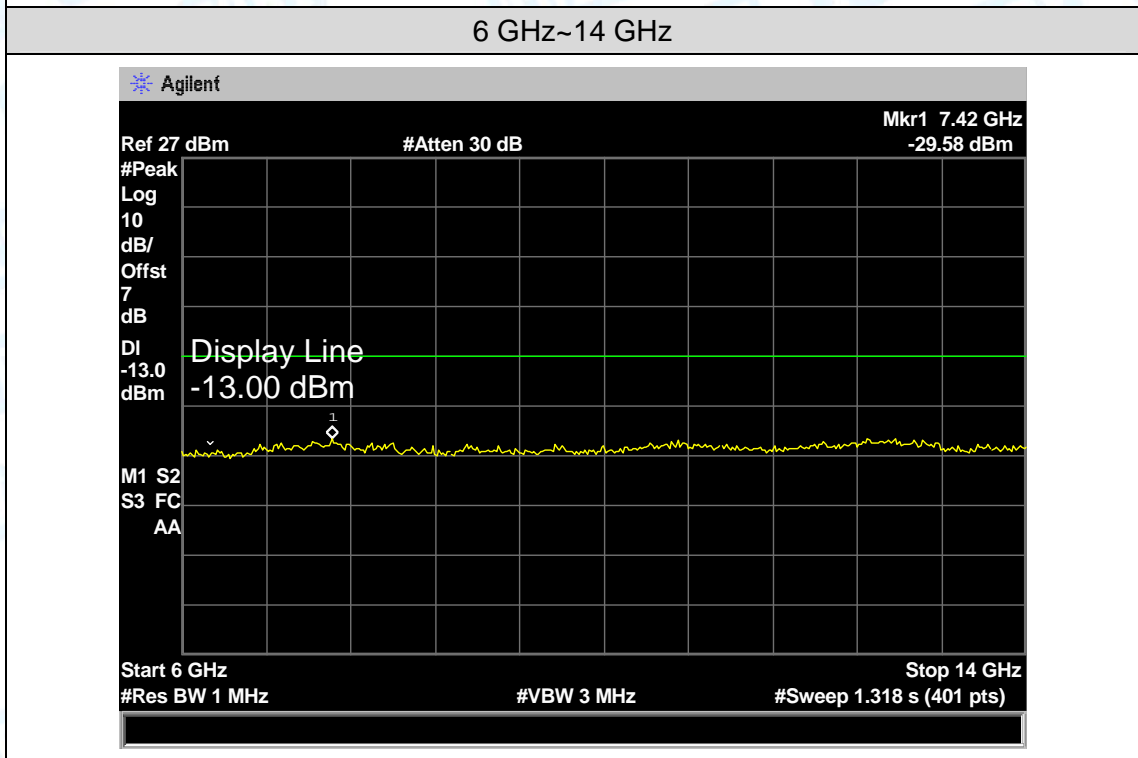
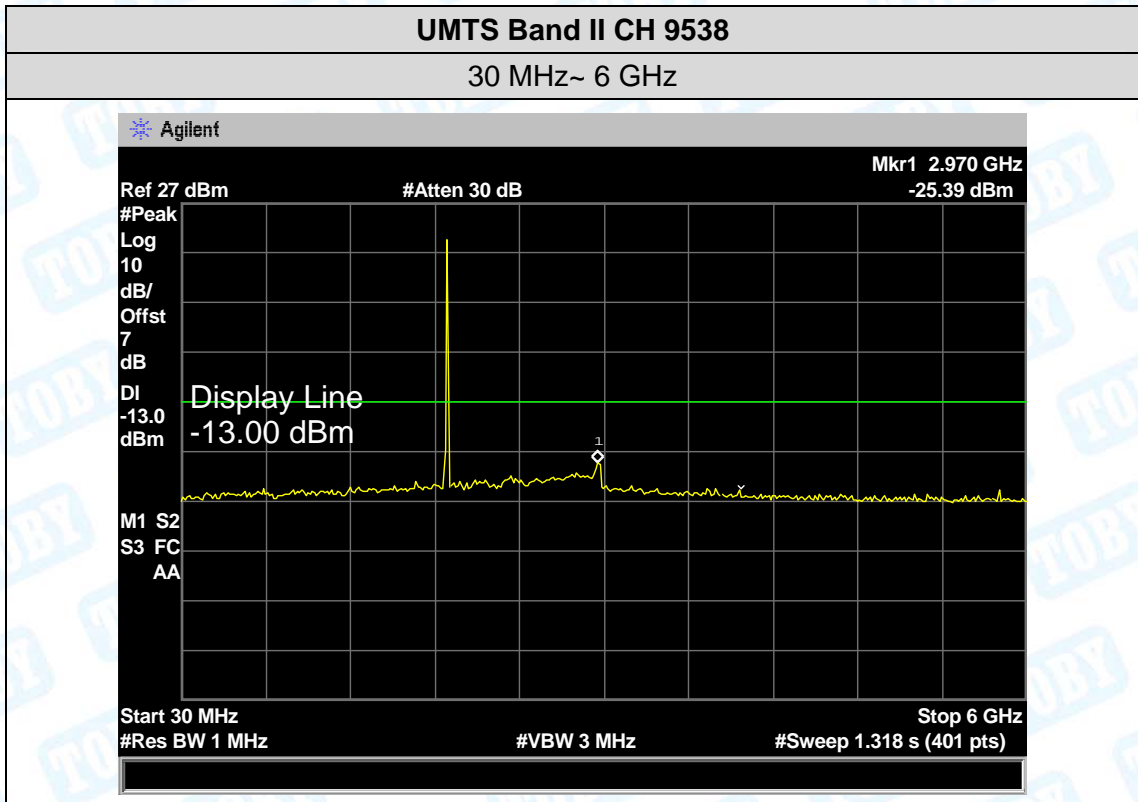

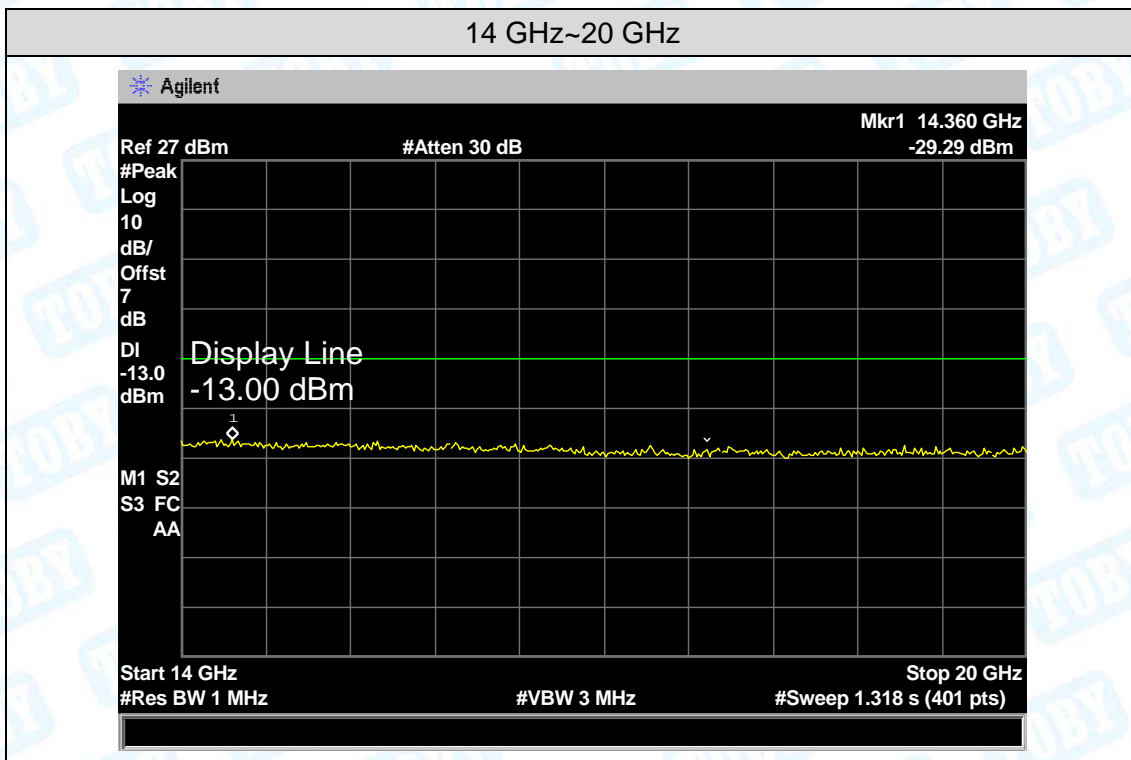

Attachment G-- Band Edge Test

Test Mode:	UMTS Band V 12.2k HSDPA
------------	-------------------------

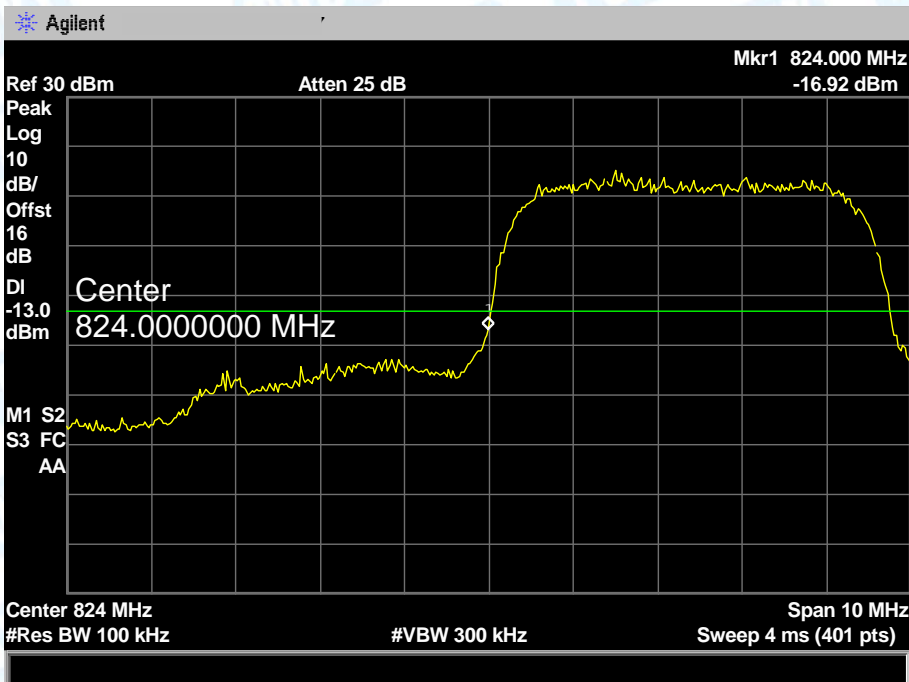

Lowest channel

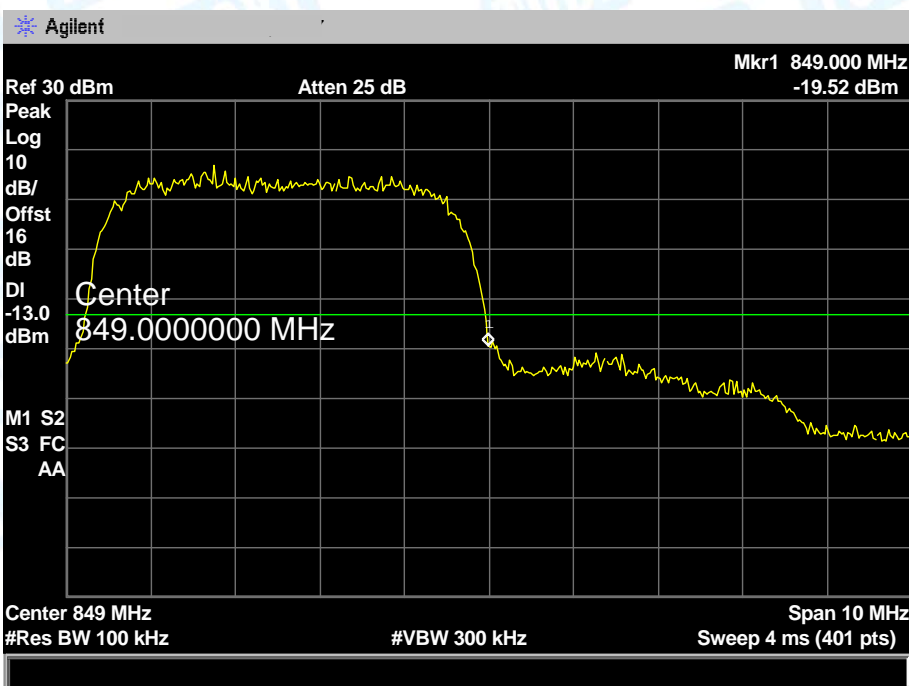

Highest channel

Test Mode: UMTS Band V 12.2k HSUPA

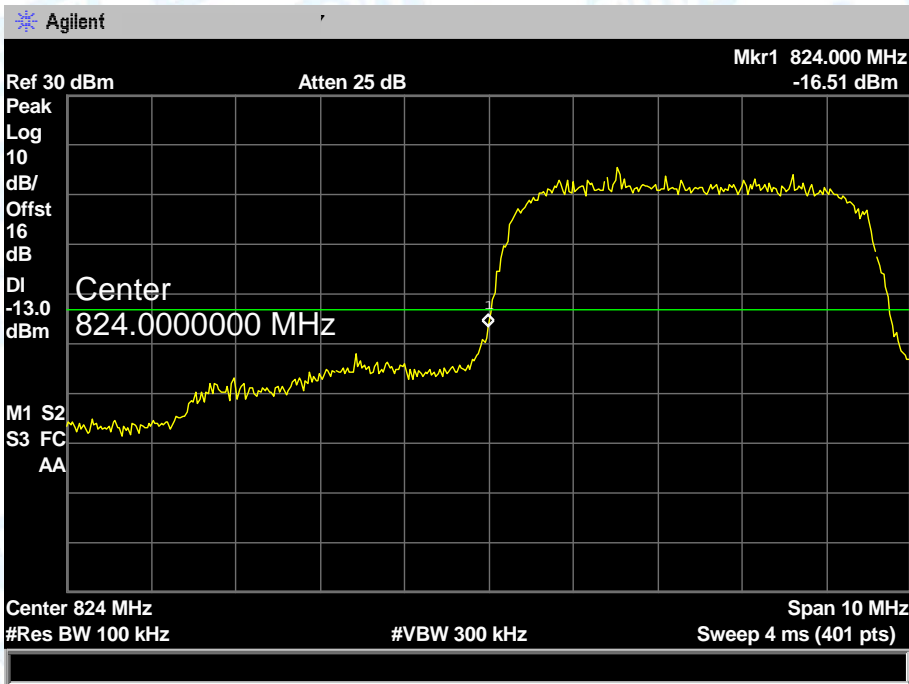

Lowest channel

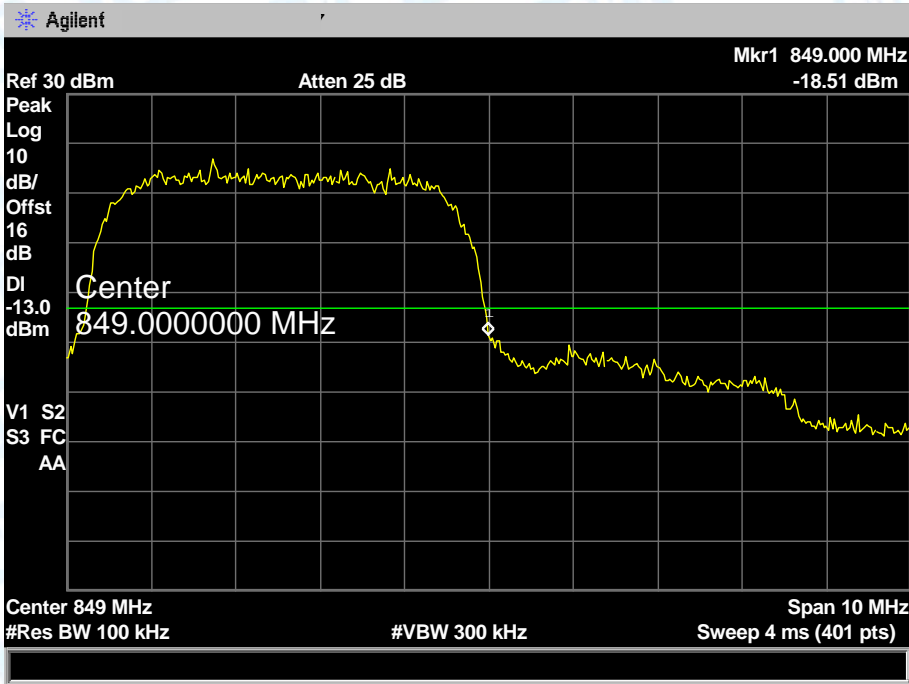

Highest channel

Test Mode: UMTS Band II 12.2k HSDPA

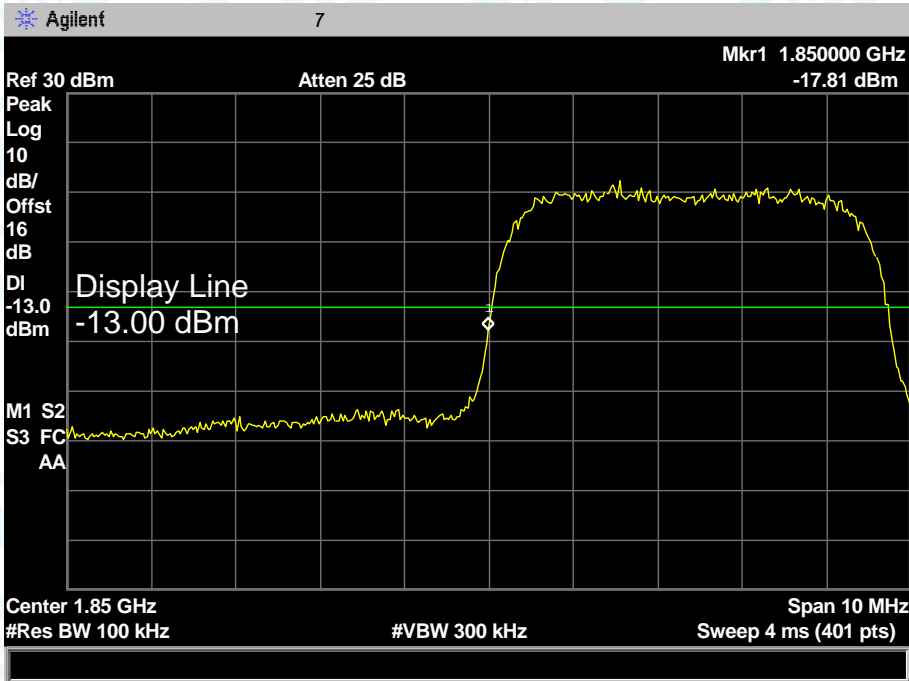

Lowest channel

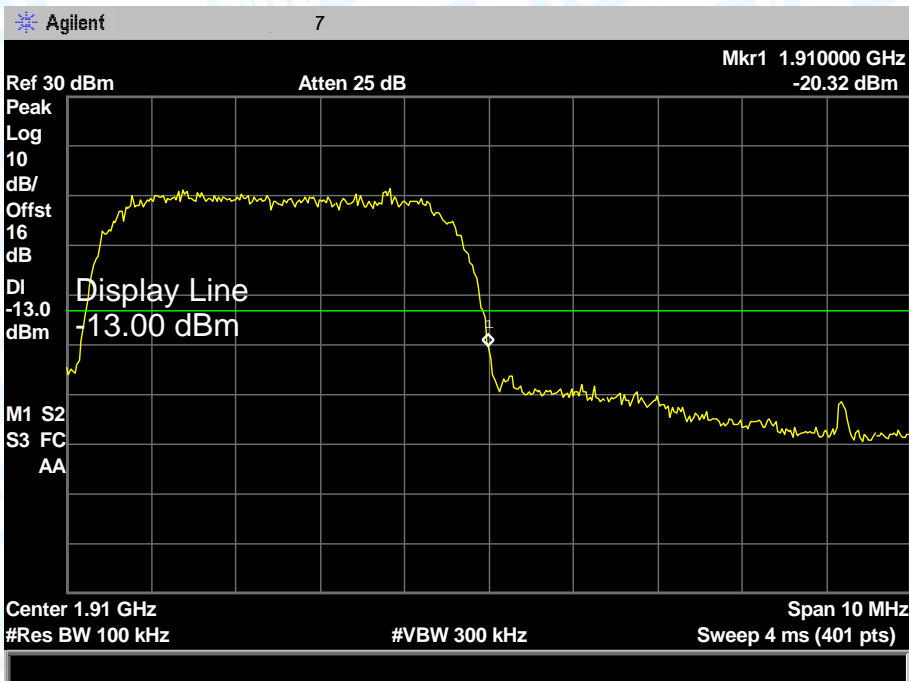

Highest channel

Test Mode: UMTS Band II 12.2k HSUPA

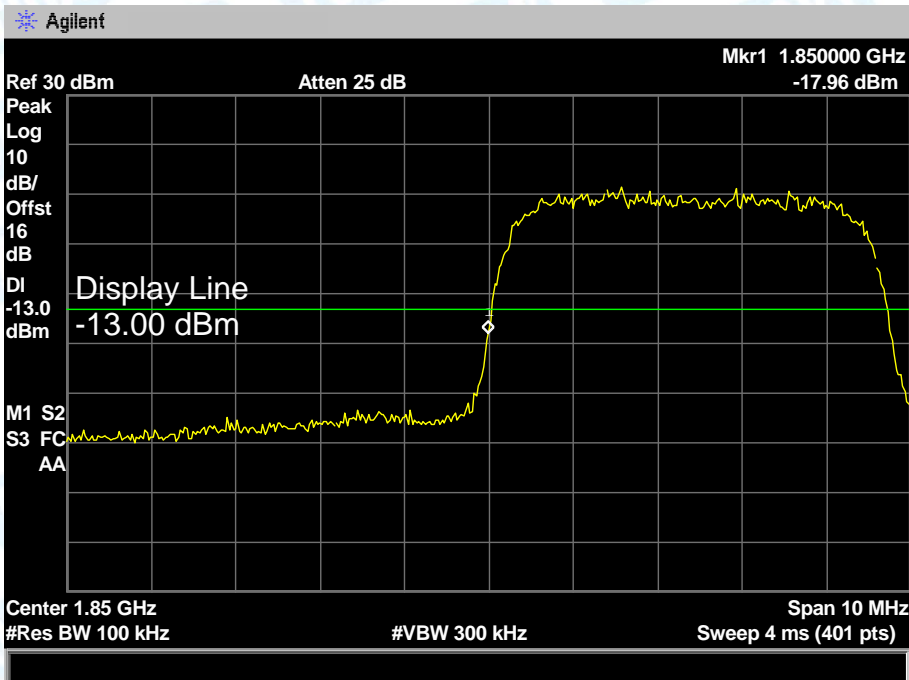

Lowest channel

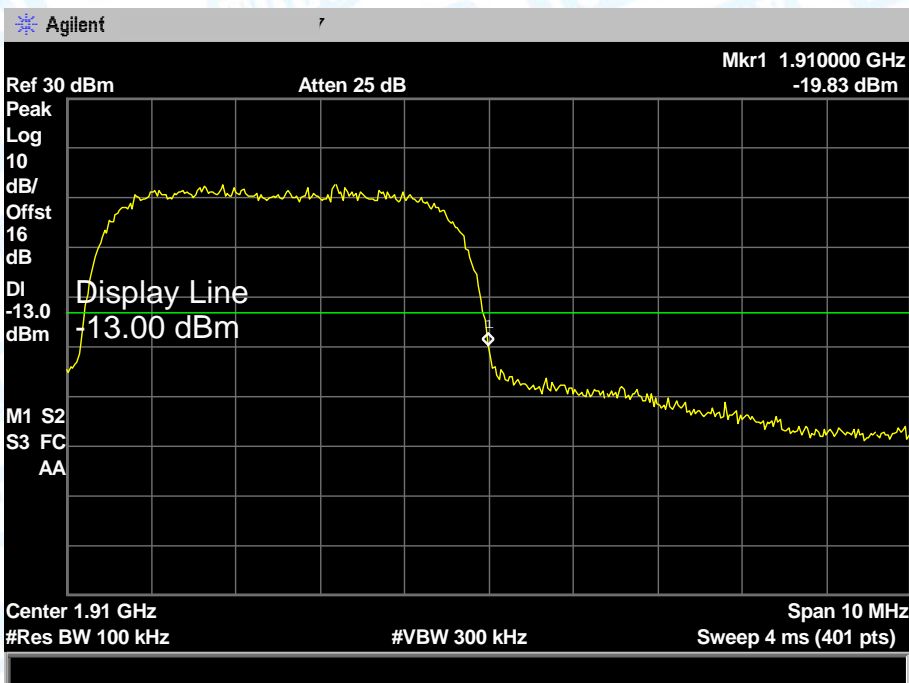

Highest channel

Attachment H--Radiated Out Band of Emissions

Measurement Data (worst case)

Test mode:	UMTS Band V RMC						
Channel:	Middle			Date of Test:	2018-12-26		
Frequency (MHz)	Spurious Emission					Limit (dBm)	Result
	Polarization (H&V)	Read Level (dBm)	Antenna Correct Factor (dBi)	Cable Loss (dB)	Emission Level (dBm)		
1673.20	Horizontal	-33.83	7.49	3.97	-22.37	-13.00	Pass
2509.80	H	-36.60	7.03	5.05	-24.52		
3346.40	H	-43.35	12.48	5.98	-24.89		
4183.00	H	---	---	---	---		
5019.60	H	---	---	---	---		
5856.20	H	---	---	---	---		
1673.20	Vertical	-33.53	8.02	3.97	-21.54	-13.00	Pass
2509.80	V	-38.94	10.47	5.05	-23.42		
3346.40	V	-47.82	16.92	5.98	-24.92		
4183.00	V	---	---	---	---		
5019.60	V	---	---	---	---		
5856.20	V	---	---	---	---		

Remark: 1, The testing has been conformed to $10 \times 836.6\text{MHz} = 8,366\text{MHz}$.
 2, All other emissions more than 30 dB below the limit.
 3, Emission Level= Read Level+ Antenna Correct Factor +Cable Loss

Test mode: UMTS Band V HSDPA							
Channel: Middle		Date of Test: 2018-12-26					
Frequency (MHz)	Spurious Emission					Limit (dBm)	Result
	Polarization (H&V)	Read Level (dBm)	Antenna Correct Factor (dBi)	Cable Loss (dB)	Emission Level (dBm)		
1673.20	Horizontal	-35.98	7.49	3.97	-24.52	-13.00	Pass
2509.80	H	-38.66	7.03	5.05	-26.58		
3346.40	H	-42.97	12.48	5.98	-24.51		
4183.00	H	---	---	---	---		
5019.60	H	---	---	---	---		
5856.20	H	---	---	---	---		
1673.20	Vertical	-33.42	8.02	3.97	-21.43	-13.00	Pass
2509.80	V	-39.16	10.47	5.05	-23.64		
3346.40	V	-47.44	16.92	5.98	-24.54		
4183.00	V	---	---	---	---		
5019.60	V	---	---	---	---		
5856.20	V	---	---	---	---		
Test mode: UMTS Band V HSUPA							
Channel: Middle		Date of Test: 2018-12-26					
Frequency (MHz)	Spurious Emission					Limit (dBm)	Result
	Polarization (H&V)	Read Level (dBm)	Antenna Correct Factor (dBi)	Cable Loss (dB)	Emission Level (dBm)		
1673.20	Horizontal	-35.11	7.49	3.97	-23.65	-13.00	Pass
2509.80	H	-37.29	7.03	5.05	-25.21		
3346.40	H	-41.84	12.48	5.98	-23.38		
4183.00	H	---	---	---	---		
5019.60	H	---	---	---	---		
5856.20	H	---	---	---	---		
1673.20	Vertical	-32.14	8.02	3.97	-20.15	-13.00	Pass
2509.80	V	-40.04	10.47	5.05	-24.52		
3346.40	V	-46.75	16.92	5.98	-23.85		
4183.00	V	---	---	---	---		
5019.60	V	---	---	---	---		
5856.20	V	---	---	---	---		
Remark: 1, The testing has been conformed to $10 \times 836.6\text{MHz} = 8,366\text{MHz}$. 2, All other emissions more than 30 dB below the limit. 3, Emission Level= Read Level+ Antenna Correct Factor +Cable Loss							

Test mode: UMTS Band II RMC							
Channel: Middle		Date of Test: 2018-12-26					
Frequency (MHz)	Spurious Emission					Limit (dBm)	Result
	Polarization (H&V)	Read Level (dBm)	Antenna Correct Factor (dBi)	Cable Loss (dB)	Emission Level (dBm)		
3760.00	Horizontal	-41.47	14.70	6.12	-20.65	-13.00	Pass
5640.00	H	-43.87	13.67	7.86	-22.34		
7520.00	H	-48.36	14.27	9.54	-24.55		
9400.00	H	---	---	---	---		
11280.00	H	---	---	---	---		
13160.00	H	---	---	---	---	-13.00	Pass
3760.00	Vertical	-43.05	15.81	6.12	-21.12		
5640.00	V	-45.12	13.80	7.86	-23.46		
7520.00	V	-47.59	13.40	9.54	-24.65		
9400.00	V	---	---	---	---		
11280.00	V	---	---	---	---		
13160.00	V	---	---	---	---		

Remark: 1, The testing has been conformed to $10 \times 1880.0\text{MHz} = 18,800\text{MHz}$.
 2, All other emissions more than 30 dB below the limit.
 3, Emission Level= Read Level+ Antenna Correct Factor +Cable Loss

Test mode: UMTS Band II HSDPA							
Channel: Middle			Date of Test: 2018-12-26				
Frequency (MHz)	Spurious Emission					Limit (dBm)	Result
	Polarization (H&V)	Read Level (dBm)	Antenna Correct Factor (dBi)	Cable Loss (dB)	Emission Level (dBm)		
3760.00	Horizontal	-41.41	14.70	6.12	-20.59	-13.00	Pass
5640.00	H	-43.87	13.67	7.86	-22.34		
7520.00	H	-47.55	14.27	9.54	-23.74		
9400.00	H	---	---	---	---		
11280.00	H	---	---	---	---		
13160.00	H	---	---	---	---		
3760.00	Vertical	-40.56	15.81	6.12	-18.63	-13.00	Pass
5640.00	V	-43.24	13.80	7.86	-21.58		
7520.00	V	-45.35	13.40	9.54	-22.41		
9400.00	V	---	---	---	---		
11280.00	V	---	---	---	---		
13160.00	V	---	---	---	---		
Test mode: UMTS Band II HSUPA							
Channel: Middle			Date of Test: 2018-12-26				
Frequency (MHz)	Spurious Emission					Limit (dBm)	Result
	Polarization (H&V)	Read Level (dBm)	Antenna Correct Factor (dBi)	Cable Loss (dB)	Emission Level (dBm)		
3760.00	Horizontal	-42.37	14.70	6.12	-21.55	-13.00	Pass
5640.00	H	-45.08	13.67	7.86	-23.55		
7520.00	H	-49.28	14.27	9.54	-25.47		
9400.00	H	---	---	---	---		
11280.00	H	---	---	---	---		
13160.00	H	---	---	---	---		
3760.00	Vertical	-42.54	15.81	6.12	-20.61	-13.00	Pass
5640.00	V	-44.20	13.80	7.86	-22.54		
7520.00	V	-47.41	13.40	9.54	-24.47		
9400.00	V	---	---	---	---		
11280.00	V	---	---	---	---		
13160.00	V	---	---	---	---		
Remark: 1, The testing has been conformed to $10 \times 1880.0\text{MHz} = 18,800\text{MHz}$. 2, All other emissions more than 30 dB below the limit. 3, Emission Level= Read Level+ Antenna Correct Factor +Cable Loss							

-----End of the Report-----