

Need more help?

amcrest.com/support

Get the most out of your Amcrest product. Check out our FAQs, instructional videos and support page.



facebook.com/amcrest



twitter.com/amcrestsecurity

1.888.212.7538

support@amcrest.com

© 2018 Amcrest Industries. All rights reserved.

Model: AC-2

Amcrest Care Video Baby Monitor

Generation 2

User Manual



A M C R E S T

Simple. Reliable. Secure.

Table of contents

FCC Statement, Welcome	3
Important Safeguards & Warnings	5
Quick Start Guide	7
1 User Manual	11
1.1 Features	11
1.2 Specification Chart	12
1.3 Package Contents	14
2 Handset Overview	15
2.1 Physical Handset Overview	15
2.2 Display On/OFF	15
2.3 Push To Talk	15
2.4 Menu	16
2.5 Tilt Up	16
2.6 Tilt Down	16
2.7 Pan Right	16
2.8 Pan Left	16
2.9 Function (Fn)	16
2.10 Power On/OFF	16
2.11 OK	16
2.12 Volume Up	17
2.13 Volume Down	17
2.14 Zoom In/Out	17
2.15 Switch Camera	17
2.16 Power Indicator	17
2.17 Link Indicator	17
2.18 Battery Cover Lock	18
2.19 DC Power Adapter Input	18
2.20 Antenna	19
2.21 Speaker	19
2.22 Clip	19
2.23 Handset Cutout	19
2.24 Battery Compartment	19
2.25 Handset Stand (Hanging Position)	20
2.26 Handset Button Menu	20
2.27 Handset Primary Buttons	20
2.28 Alternate Functions	21
2.29 Menu Icon Overview	21
3 Camera Overview	22
3.0 Physical Handset Overview	22
3.1 Optic Lens	22
3.2 IR LED Array	22

3.3 Ambient Light Sensor	22
3.4 Nightlight	22
3.5 Speaker	23
3.6 Antenna	23
3.7 Thermometer Probe	23
3.8 On/Off Switch	23
3.9 Power Adapter Input	23
3.10 Service Port	24
3.11 Pairing Button	24
3.12 Wall Mount	24
4 Camera Overview	25
4.1 Powering the Camera Unit	25
4.2 Installation of Handset Battery	25
4.3 Charging	26
4.4 Pairing Your Handset & Camera	26
4.5 Wall Mounting The Camera Unit	27
4.6 Charging	28
5 Usign The Amcrest Care Monitor ...	29
5.1 Setting Up Your Camera	29
5.2 Alternate Functions	29
5.3 Pan & Tilt	29
5.4 Night Vision	29
5.5 Talk Mode	30
5.6 Sellep Mode	30
5.7 Screen Timer and VOX	30
5.8 Colume control	31
5.9 Screen Brightness	32
5.10 Digital Zoom	32
5.11 Adding & Removing Cameras	32
5.12 View Different Cemerars	33
5.13 Lullaby	33
5.14 Nightlight	34
5.15 Terperature Display	34
FAQs/Troubleshooting	35



If your experience has been something less than amazing, please give us a ring at

1-888-212-7538

FCC Statement

1- This device complies with Part 15 of the FCC Rules. Operation is subject to the following two conditions: (1) this device may not cause harmful interference, and (2) this device must accept any interference received, including interference that may cause undesired operation.

2-The users manual or instruction manual for an intentional or unintentional radiator shall caution the user that changes or modifications not expressly approved by the party responsible for compliance could void the user's authority to operate the equipment. In cases where the manual is provided only in a form other than paper, such as on a computer disk or over the Internet, the information required by this section may be included in the manual in that alternative form, provided the user can reasonably be expected to have the capability to access information in that form.

3- (b) For a Class B digital device or peripheral, the instructions furnished the user shall include the following or similar statement, placed in a prominent location in the text of the manual: NOTE: This equipment has been tested and found to comply with the limits for a Class B digital device, pursuant to Part 15 of the FCC Rules. These limits are designed to provide reasonable protection against harmful interference in a residential installation. This equipment generates, uses and can radiate radio frequency energy and, if not installed and used in accordance with the instructions, may cause harmful interference to radio communications. However, there is no guarantee that interference will not occur in a particular installation. If this equipment does cause harmful interference to radio or television reception, which can be determined by turning the equipment off and on, the user is encouraged to try to correct the interference by one or more of the following measures:

- ▶ Reorient or relocate the receiving antenna.
- ▶ Increase the separation between the equipment and receiver.
- ▶ Connect the equipment into an outlet on a circuit different from that to which the receiver is connected.
- ▶ Consult the dealer or an experienced radio/TV technician for help.

RF exposure warning: This equipment must be installed and operated in accordance with provided instructions and the antenna(s) used for this transmitter must be installed to provide a separation distance of at least 20 cm from all persons and must not be co-located or operating in conjunction with any other antenna or transmitter. End-users and installers must be provide with antenna installation instructions and transmitter operating conditions for satisfying RF exposure compliance.

Welcome to the Amcrest Family!

Thank you for purchasing our Amcrest Care! This user manual is designed to be a reference for the installation and operation of your camera. Here you can find information about the camera's features and functions, as well as information to aid in troubleshooting. It is important to read this user manual carefully and in its entirety as it contains detailed information needed to properly use your Amcrest Care. If you have any issues setting up or using your Amcrest baby monitor, please call our Customer Support.

For access to the quick start guide and other support information, go to www.amcrest.com/babycam

To contact Amcrest support, please do one of the following:

Visit www.amcrest.com/contacts and use the email form Call Amcrest Support using one of the following numbers

Toll Free: (888) 212-7538
International Callers (Outside of US):
+1-713-893-8956
USA: (888) 212-7538
Canada: 437-888-0177
UK: 203-769-2757

Email Amcrest Customer Support
support@amcrest.com

Important Safeguards & Warnings

1. Electrical Safety

All installation and operation should conform to your local electrical safety codes. The product must be grounded to reduce the risk of electric shock. We assume no liability or responsibility for any fires or electrical shock caused by improper handling or installation.

2. Transportation Security

Heavy stress, violent vibrations, and excess moisture should not occur during transportation, storage, and installation of the device.

3. Repair Professionals

All examination and repair work should be done by qualified service engineers. We are not liable for any problems caused by unauthorized modifications or user-attempted repair.

4. Environment

This device should be installed and kept in a cool, dry place away from direct sunlight, flammable materials, explosive substances, etc. This product should be transported, stored, and used only in the specified environments as stated above.

5. Accessories

Be sure to use only the accessories recommended by the manufacturer. Before installation, please open the package and check to ensure that all of the components are present. Contact the retailer that you purchased from or Amcrest directly if anything is broken or missing in the package.

Important Safety Information

This product is designed to be an aid and should not be used to substitute responsible and proper adult supervision.

This product is designed to provide sound and video transmission for those times when a responsible adult is not in the same room as the baby in care.

This baby monitor is not a medical device, nor a device to prevent cases of Sudden Infant Death Syndrome (SIDS). Do not solely rely on it for a baby's wellbeing. It is important to regularly check on the baby in care in person.

Make sure the camera, handset, and power adaptor cables are kept out of reach, at least one yard away, from your baby and other young children at all times. Never place the camera unit or handset unit inside your baby's bed or playpen. Ensure that all device components are well out of the reach of your child at all times. Never cover the handset or baby unit with clothing, towels or blankets, or any other item. Ensure that all components associated with this device are not subject to moisture or liquid (e.g. near bath or pool). Immersing in water could cause electric shock and even death. Upon installation, maintain a distance of at least one yard from other electronic equipment, such as microwave ovens or Wi-Fi routers, otherwise, Electromagnetic frequency interference may be experienced. During continual use, the baby unit power adaptors may become warm to the touch. This is normal and should not be a concern.

Battery Safety

Batteries may represent a hazard to your health and the environment.

Do not dispose of batteries in a fire as they may explode. Dispose of batteries according to local regulations, never in your household rubbish as they contain toxic, ecologically hazardous heavy metals.

- ▶ Do not open, bend, puncture, or shred batteries. If a battery leaks, do not let the battery liquid touch skin or eyes. If this happens, immediately flush the affected areas with water, and seek medical assistance.
- ▶ Do not modify or attempt to insert foreign objects into the battery or expose it to any liquids. Batteries may explode or leak if damaged.
- ▶ Use only the battery supplied with the product. Use of unapproved batteries may present a risk of fire, explosion, or other hazards, and will nullify the device warranty.

Quick Start Guide

Connection & Installation

This section provides information about pairing the handset with the camera.

Powering on the Camera

- 1 Connect the included power adapter to a wall outlet.
- 2 Connect the camera to the power adapter.
- 3 Slide the ON/OFF switch to the ON position.

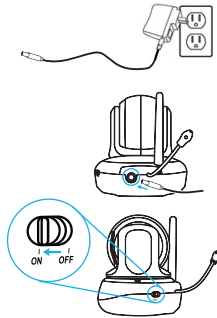

Powering on the Handset

- 1 Connect the included power adapter to a wall outlet.
- 2 Connect the handset to the power adapter.
- 3 Press and hold the power button until the handset powers on.

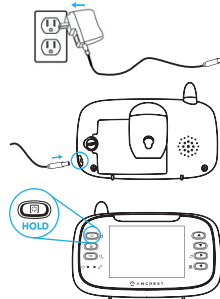

Once powered on, a battery icon with a lightning bolt will display on the upper right-hand of the screen. This indicates the handset is charging. When the handset is completely charged, the battery indicator shown on the screen will be full and you may disconnect it from the charging cable as desired.

Pairing your Handset & Camera

By default, the camera and the handset comes paired and should be ready to use, However, If for any reason pairing needs to be reestablished between the handset and the camera, please Follow these instructions:









- 1 Within the handset menu please navigate to the setting icon
- 2 Next, navigate to "Add" and press the **OK** button located between the standby and **MENU** buttons on the handset face.
- 3 Now, select a channel and press **OK** to start the pairing process.
- 4 Located under the camera, press and hold the **pair** button while the camera is powered on. If the pairing process was completed within the allotted time, you should see an image captured by the camera unit.

! Please note that the handset will only pair within 15 seconds. If the camera does not pair within this time you will need to begin the process again.







Handset Button Menu

Icon	Description	Options
	Display	On/Off
	Push to Talk	Press and Hold to Speak
MENU	Menu	Configuration Settings
	Tilt Up	Tilt Camera Up
	Tilt Down	Tilt Camera Down
	Pan Right	Pan Camera Right
	Pan Left	Pan Camera Left
ON	Power	Indicates if the device is powered on or off.
link	Link	Indicates the status of the connected cameras. When lit indicates there is no link.

Menu Icons Overview

Icon	Description	Options
	Volume	5 Levels
	Screen Brightness	5 Levels
	Night Light	On/OFF
	Lullaby Music	5 Lullabies, All
	Sleep Mode Delay	1 Min, 3 Min, 4 Min
	Camera Options	Del, Add, View, Scan
	VOX Voice Detection Sensitivity	Adjust Voice Detection Sensitivity
	Current Camera Unit Temperature	1-36 °C / 34-97 °F

Alternative Function (Fn) Icons

Icon	Description	Options
	Power	On/Off
OK	OK	Confirm Selections
	Alternative Function	Activate Alternative Function
	Volume Up	Turn Volume Up
	Volume Down	Turn Volume Down
	Zoom	Enable/Disable
	Camera Scan	Scan Between Cameras Feeds



For access to the quick start guide and other support information, go to

www.Amcrest.com/babycam

Troubleshooting

Device does not turn on:

- › Confirm the camera and monitor unit are both ON (check Power LED indicator).
- › Check that both handset and camera units are charged or plugged into a charger.
- › Battery may be depleted and may need to be recharged or replaced.
- › Check that power adapters are connected correctly.

"Out of Range" displaying on handset unit:

- › Move the handset closer to the camera unit.
- › Register the camera to the handset unit.
- › Reset both units by disconnecting them from battery and electrical power. Wait about 15 seconds then reconnect and pair.
- › Large metallic objects including mirrors, doors, refrigerators, fillings cabinets, may also block radio signal if it is between the two units.
- › Signal strength may be reduced when in close proximity to radio or other electrical equipment such as TVs, computers, phones, fluorescent light, or dimmer switches.
- › Use of 2.4Hz product such as WiFi routers, Bluetooth systems, or microwave ovens may cause interference. Keep camera and handset units at least 5ft from these items or turn them off.

Reception Interference:

- › The camera and handset units may be too far apart. Move the handset unit closer to the camera unit.
- › The battery power may be too low.
- › Check for interference from other electronic devices.
- › Handset and camera unit may be too close in proximity to large metallic objects causing interference.
- › Use of 2.4Hz product such as WiFi routers, Bluetooth systems, or microwave ovens may cause interference. Keep camera and handset units at least 5ft from these items or turn them off.

High pitched noise from handset unit:

- › Increase the distance between the handset and camera unit.
- › Volume may be too high. Reduce the volume on the handset unit.
- › Camera unit may be too far from the handset unit. Move the camera unit closer to the handset unit.
- › Make sure camera and handset units are placed away from other electrical equipment, such as television, computer, or phone.

1 User Manual

The Amcrest Care system is an excellent product that can be useful to a wide variety of users that have babies or small children to monitor. Once paired, the camera connects to the handset for in home real-time viewing to provide an added sense of security for your child's wellbeing.

1.1 Features

Amcrest Care system has the following features:

Pan, Tilt, and Zoom

Camera panning, tilting, and zooming are all features available that allow peace of mind by knowing that your child is safe. Pan into an area, tilt up, down, side to side, and zoom in for a closer look.

Real Time Viewing

See what's going on right now and view your child in real-time. No delay or lag, just pick up the handset and watch your child whenever you need.

Two-Way Communication

Always hear your child through the handset via the camera. The Amcrest Care comes with the added benefit of two-way communication. Speak through the handset to the location of the camera. This is especially helpful when calming a baby or speaking to a caretaker.

VOX

See and hear your child through your handset as soon as they make a noise or any other sound detected by VOX. This useful feature allows the user to set the appropriate ambient sound in the room. The monitor will wake up and display an image of what is happening when sound is detected in the camera viewing area.

Lullaby

Whether it's time for a nap or time for bed, we have incorporated lullabies to help soothe your baby to sleep. Pick from five classic lullabies or play all of them, one after another.

Night Vision

The Amcrest Care system includes night vision that will automatically illuminate a dark room without extra steps. This feature is non-visible to the naked eye and allows you to view your child without disturbing them.

1.2 Specification Chart



Display

LCD Type	3.5" Color TFT 320 x 240
LCD Backlight	Yes
Display Language	On / Off is English, others by icons
Time / Date in Idle Display	No

Parent Unit Indicator

LED Indicators	Change power / battery low / charge = Green Color Unlink / Out of Range = Red Color Voice Level = 3pcs green color and 2pcs red color
Battery Indication	Display on LCD
Battery Low Warning Indicator	3 levels + empty in LCD icon
Out of Range Indication	Yes, Unlink LED flash
Baby Unit Sound Level Indication	5 LEDs (3 green + 2 red)
Baby Unit Sound Level Alert	No

General Features

Communication Type	2-Way
Remote Control Baby Unit	Yes (night light on/off; Lullabies selections, Lullabies, Play/Stop and Pan / Tilt)
Belt-Clip	Yes (Non-Detachable)
Antenna Type	External Fixed
Zoom In	Yes, 2X (Can Pan/Tilt by long press menu key)
Microphone	Yes, as push to talk
Microphone Sensitivity (VOX)	6 levels (Off, 1, 2, 3, 4, 5) Default: 3
Speakerphone Volume Level	6 levels (Off, 1, 2, 3, 4, 5) Default: 3
Temperature Alert	Visual Indicator
Temperature Display	(Degree C / F selection)
DC Jack	Yes (Unit works with or without battery inserted)
Power Adaptor	Switching Mode Adaptor: 5.9V 1A



Baby Camera

Key	Power On / Off Slide Key Pairing Key
CMOS Sensor	VGA, 640 x 480 pixels
Imaging Device	5/1" CMOS
Lens Focal Length	F2.8mm
Angular Field of View (Horizontal)	Degree 50
Max Aperture Ratio	F2.8
Night Vision	8pcs IR LED - 940nm
Antenna	External
Temperature Sensor	Yes
Light Sensor	Yes
Wall Mount Holes	Yes
Indicators	Power LED
Power indicator	Yes
Microphone	Yes
Speaker	Yes
Pan Angle (Horizontal)	300°
Tilt Angle (Vertical)	110°
Night Light	Menu Selectable On / Of Default: On
Lullabies	Yes, 5 songs
Backup Battery Type	No
DC Jack	Yes
Power Adaptor	Switching Mode Adaptor : 5.9V 1A



For access to the quick start guide and other support information, go to

www.amcrest.com/babycam

1.3 Package Contents

AC-2

Wireless Pan/Tilt Baby Camera with 3.5" Color Monitor

1 x Camera Unit



1 x Parent Handset

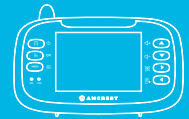

1 x Battery



2 x Power Adapter

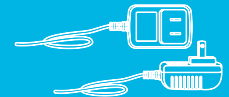

1 x Screw and Wall Fishers



1 x User Manual & Reference Card



2 Handset Overview

2.1 Physical Handset Overview

In this section we cover the features and functionality of your Amcrest Care handset.

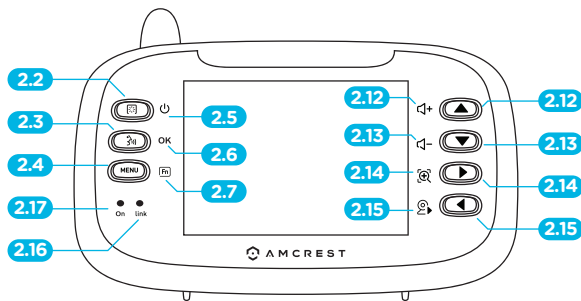

- | | |
|--------------------------------|-------------------------------|
| 2.2 Display On/Off | 2.3 Push to Talk |
| 2.4 Menu | 2.5 Power On/Off |
| 2.6 OK | 2.7 Function |
| 2.8 Volume Up | 2.9 Volume Down |
| 2.10 Zoom In/Out | 2.11 Switch Camera |
| 2.12 Movement/Pan Up | 2.13 Movement/Pan Down |
| 2.14 Movement/Pan Right | 2.15 Movement/Pan Left |
| 2.16 Power Indicator | 2.17 Link Indicator |

2.2 Display On/Off

This button serves two functions: to power the device on and off, and to turn off the screen. Press and hold the button to power on the device. Inversely, press and hold this button to power off the handset. To only turn off the screen while the handset is on, quickly press this button. This will allow the screen to turn on when the VOX sound sensitivity threshold is met if this function is active (see section 5.6 for more details).

2.3 Push To Talk

Press and hold the talk button to activate the microphone on the handset. This function will engage the user's voice and transmit it through to the speaker on the camera.

2.4 Menu

To view the menu button, press once and release the menu button. The menu for the handset configuration will present on screen (see section 5 for more information on menu options).

2.5 Tilt Up

By default, this button allows the user to tilt the camera up to better assist with seeing activity in the child's room.

2.6 Tilt Down

By default, this button allows the user to tilt the camera down to better assist with seeing activity in the child's room.

2.7 Pan Right

By default, this button allows the user to pan the camera right to better assist with seeing activity in the child's room.

2.8 Pan Left

By default, this button allows the user to pan the camera left to better assist with seeing activity in the child's room.

2.9 Function (Fn)

Hold the Function (Fn) button for two seconds to activate the use of alternate buttons shown on the face of the handset. The symbols or letters next to the buttons are the alternate functions which include Power, OK, FN, Volume Up, Volume Down, Zoom, and Switch Camera. Once the Fn button is activated, the icon will display across the top of the screen. For instance, the alternate function of the pan up button is to increase the volume.

2.10 Power On/Off

The alternate function of the Display On/Off button when the FN feature is enabled (see section 2.9) is to power the device on and off. When the device is turned off, press and hold the button power on the device. Inversely, when the handset is fully powered on, press and hold this button to turn the handset completely off. To only turn off the screen when the handset is powered on, quickly press this button once. This will allow the screen to turn on when the VOX sound sensitivity threshold is met if this function is active (see section 5.6 for more details).

2.11 OK

The alternate function of the Push to Talk button when the Fn feature is enabled (see section 2.10) is to approve selections. The OK function confirms selec-

tions made on the camera configuration menus. For instance, when adding or removing a camera from the handset, this button will be used to confirm the action.

2.12 Volume Up

The alternate function of the Pan Up button when the Fn feature is enabled (see section 2.10) is to increase the volume to the handset. This allows the audio's volume from the camera's monitoring area heard through the handset to be adjusted.

2.13 Volume Down

The alternate function of the Pan Down button when the Fn feature is enabled (see section 2.10) is to lower the volume to the handset. This allows the audio's volume from the camera's monitoring area heard through the handset to be adjusted.

2.14 Zoom In/Out

The alternate function of the Pan Right button when the Fn feature is enabled (see section 2.10) is for zooming. This function allows the user to toggle the zoom feature of the camera. There are two options to this feature, zoom disabled and zoom enabled.

2.15 Switch Camera

The alternate function of the Pan Left when the Fn feature is enabled (as described in section 2.10) allows the user to cycle between 4 camera feeds and continuous scan. The options to this function are as follows: Camera 1, Camera 2, Camera 3, Camera 4, and Scan.

2.16 Power Indicator

The power indicator displays whether the device is powered on and active. When powered on the power indicator will be lit green. While off the power indicator will be off.

2.17 Link Indicator

The link indicator displays the status of the current camera being viewed. When the indicator is lit the camera is either out of range or needs to be paired with the handset again. To pair your device with the handset please see page 6: Pairing your handset & camera

Note

Scan cycle through the video images for connected cameras. Each camera feed will rotate every 10 seconds then the next camera feed will be shown.

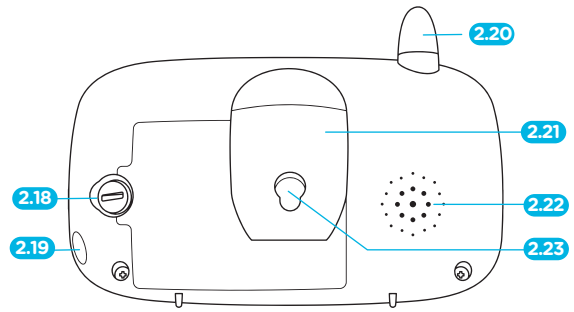

- | | | | |
|------|------------------------|------|----------------------|
| 2.18 | Battery Cover Lock | 2.21 | Handset Stand |
| 2.19 | DC Power Adapter Input | 2.22 | Speaker |
| 2.20 | Antenna | 2.23 | Wall Mounting Cutout |

2.18 Battery Cover Lock

Located on the back of the handset is a hinged door that is latched by a circular lock. Behind this door is the battery compartment. If servicing the battery is needed, a coin or flat head screwdriver can be used to turn the circular lock counterclockwise to open the compartment.

To install or remove the included battery: 1.Remove the back of the battery compartment on the handset using a coin or flat head screwdriver. 2.Insert the included battery into the compartment. Ensure the battery makes contact with the terminals inside the handset. Keep in mind that the battery is keyed and can only be inserted one way. 3.Replace the battery cover on the back of the handset and secure the compartment lid by turning the lock clockwise with a coin or screwdriver.

2.19 DC Power Adapter Input

The Amcrest Care handset can be powered via battery or DC power input. Charge the battery to full power or connect the included power adapter to the handset's DC power input and to an electrical outlet. To ensure safety, please note that only the included Amcrest power adapter should be used with this handset and/or camera.

With the handset now plugged into the wall, notice the power LED will light an amber color. A battery icon with a lightning bolt will display in the upper right-hand corner of the screen. This indicates the handset is charging. When the handset is completely charged, notice the battery icon will show four full bars. The DC power adapter can be removed from the handset at this point, although, it is not necessary to remove the handset from

the charger when the battery is completely full.

2.20 Antenna

Located at the top of the handset is a stationary antenna used to communicate with the camera. The antenna protrudes slightly from the top of the handset. This antenna is nonadjustable and will remain as received throughout the life of the Amcrest Care View camera operation.

2.21 Speaker

Located on the back of the handset unit is a speaker. This speaker is used to hear audio captured by the camera unit's viewing area. The volume of this speaker may be controlled in the menu and via two buttons on the front of the camera. See section 2.12 and 2.13 for further information on how to adjust volume.

2.22 Clip

This clip has the ability to hold the handset in an upright position on a countertop or another flat surface.

Note

Please note that the handset will show temperatures up to 85 F / 29 C. If "HH" is shown this indicates High Heat in the room.

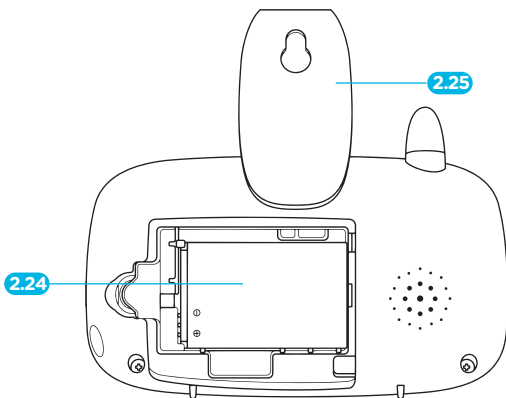

2.24 Battery Compartment

2.25 Handset Stand

2.23 Handset Cutout

Rotate 108 degrees to hang from a wall hanger, screw or nail.

2.24 Battery Compartment

Within the battery compartment, there is a 3.7 1800mAh battery used to power the handset when not plugged into the charger. Please note that this battery should only be replaced by Amcrest Technologies.

2.25 Handset Stand (Hanging Position)

Rotate the stand 180 degrees to invert it for hanging by the integrated belt clip. While in the inverted position, noticed the punched out section used for hanging the handset unit from a wall hanger, nail, or screw. This allows the ability to mount the device to a wall or another flat vertical surface.

2.26 Handset Button Menu



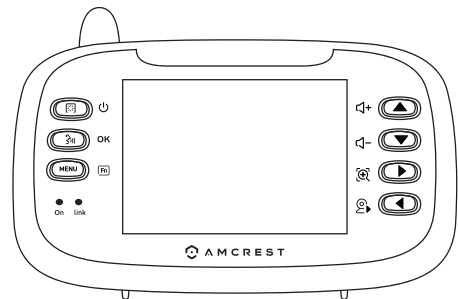



In this section we cover the features and functionality of your Amcrest Care handset.









2.27 Handset Primary Buttons

Icon	Description	Options
	Display	On/Off
	Push to Talk	Press and Hold to Speak
MENU	Menu	Configuration Settings
	Tilt Up	Tilt Camera Up
	Tilt Down	Tilt Camera Down
	Pan Right	Pan Camera Right
	Pan Left	Pan Camera Left
ON	Power	Indicates if the device is powered on or off.
link	Link	Indicates the status of the connected cameras. When lit indicates there is no link.

2.28 Alternate Functions

Icon	Description	Options
	Power	On/Off
OK	OK	Confirm Selections
	Alternative Function	Activate Alternative Function
	Volume Up	Turn Volume Up
	Volume Down	Turn Volume Down
	Zoom	Enable/Disable
	Camera Scan	Scan Between Cameras Feeds

2.29 Menu Icon Overview

Icon	Description	Options
	Power	On/Off
OK	OK	Confirm Selections
	Alternative Function	Activate Alternative Function
	Volume Up	Turn Volume Up
	Volume Down	Turn Volume Down
	Zoom	Enable/Disable
	Camera Scan	Scan Between Cameras Feeds



For access to the quick start guide and other support information, go to

www.amcrest.com/babycam

3 Camera Overview

3.1 Physical Camera Overview

In this section we cover the features and functionality of your Amcrest Care camera.

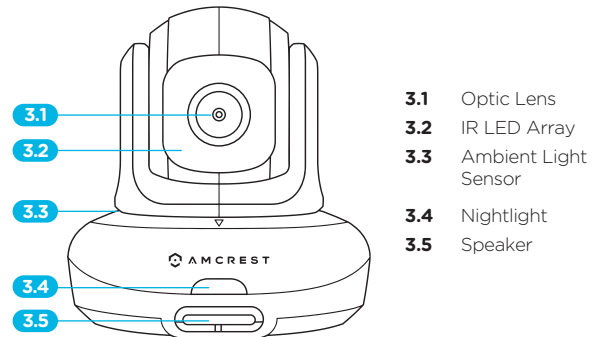

3.1 Optic Lens

The camera unit is equipped with a VGA, 640x480 sensor that is capable of capturing full light, low light, and night vision scenarios. Do not directly touch the camera lens. If the lens needs cleaning, please use a lint free microfiber cloth.

3.2 IR LED Array

Located behind the black, glossy plastic and around the optic lens on the camera is an infrared LED array. In low or no light, this array emits a non-visible light spectrum which is used to produce an image. This is especially helpful for monitoring at night.

3.3 Ambient Light Sensor

The ambient light sensor located on top of the camera base is used to examine the surrounding light. When the surrounding light is low, the sensor will trigger the non-visible night vision LEDs.

3.4 Nightlight

The night vision feature is located behind a tinted plastic lens that surrounds the camera lens. It is important that the lens remain uncovered for the night vision feature to properly function. Please note that the night vision feature is automatically triggered by the ambient light sensor as described in section 3.3.

3.5 Speaker

Located on the bottom front of the camera unit is a speaker used for two-way communication. This speaker is used to project the user's voice when spoken into the handset while holding the "talk" button on it.

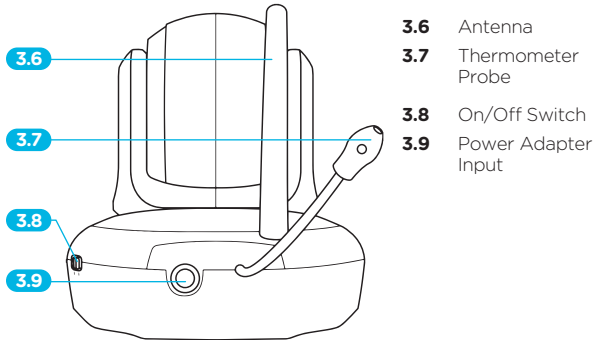

- 3.6 Antenna
- 3.7 Thermometer Probe
- 3.8 On/Off Switch
- 3.9 Power Adapter Input

3.6 Antenna

The antenna located on the back of the camera is used to communicate with the handset and should be kept no closer than one yard from radio frequency, Wi-Fi, or microwave devices. This is to ensure the camera and handset are able to properly communicate without signal loss. Please see the Important Safeguards and Warnings for further information on proper operation.

3.7 Thermometer Probe

Located on the back of the camera unit is a thermometer probe. The thermometer probe is used to read the camera's monitoring area's temperature. It is important that the camera is placed away from sources of heat and cold for an accurate reading of the ambient temperature. All readings are taken by the probe and will be shown in the handset unit.

3.8 On/Off Switch

The On/Off switch is located on the right side base of the camera. Once the power is connected to the power input, move the switch to the On position. With the power switch in the On position, the camera will boot up and be ready for use. Remember to turn the switch to the Off position before disconnecting the power.

3.9 Power Adapter Input

To the right of the temperature probe is an input for the power adapter. Connect the included power adapter to this input by taking the small end of the power adapter and inserting it firmly. Chargers supplied by Amcrest are rated as center post positive 5.9v and should only be used with your Amcrest Care camera.

Note

Keep the power cable at least 3 feet out of the reach of your child's bed or play area. At no point should a child play with or be able to reach this cable as it may pose a serious risk.

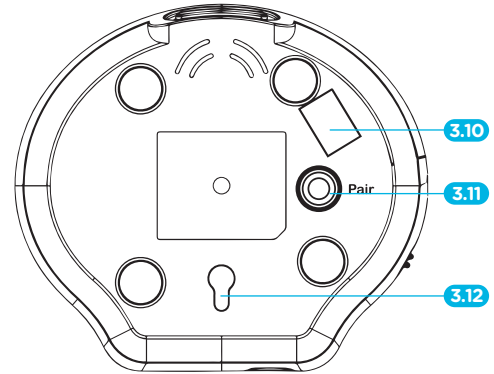

- 3.10 Service Port (Please don't remove)
- 3.11 Pair Button
- 3.12 Wall Mounting Option

3.10 Service Port

This service port located on the bottom of the camera is for maintenance via Amcrest Technologies. Please do not remove the protective covering.

3.11 Pairing Button

This button is used to pair the camera to the handset. When the handset is in pairing mode, this button must be pressed and held until a video feed is shown on the handset. For further information on how to pair the camera with the handset. Please reference section 4.4 for further information on how to pair the camera with the handset.

3.12 Wall Mount

The wall mount located on the bottom of the camera is used to mount the camera to vertical surfaces like walls. When using this mount, it is important to adhere to the safeguards and warnings as improper placement pose a risk to your child.

Please make note to use a drywall anchor to ensure the camera will not fall from the wall when unattended.

Once the drywall anchor is mounted and the screw is threaded into it, insert the screw head into the larger opening. Then slide the camera down so that the screw head slips into the tapered half of the opening.

4 Connection & Installation

4.1 Powering the Camera Unit

- 1 Connect the camera to the power outlet using the camera power adapter.
- 2 Slide the ON/OFF switch to the ON position.
- 3 Position the camera no less than 3 feet from the baby's crib or play area. Ensure that the power cord is not within reach of the baby's crib or play area.

Note

Only use the included power adapter that came in the box with your Amcrest Care.

4.2 Installation of Handset Battery

Check to ensure that the parent handset and handset battery are in the box.

- 1 On the back of the handset, there is a panel with a plastic screw head that is notched for a flat head screwdriver. Use a flathead screwdriver or a large coin to turn the plastic screw counter clockwise to open the panel.
- 2 Insert the battery with the contacts on the bottom left of the compartment so it meets the contacts of the handset.
- 3 Place the handset battery compartment cover back on the handset and turn the plastic screw head clockwise so it locks shut.

After following the previous steps in this section, we recommend using the included power adapter to fully charge the handset before initial use. After the handset is fully charged, notice the battery icon in the upper right-hand corner of the display will show as full.

When the handset is fully charged, unplug the charger. To turn the handset on, press and hold the power button in the upper left corner on the handset

face until the Amcrest logo appears. At this time, release the power button and the handset will start up.

Note

The handset unit was designed to continue operating as usual when the battery is charging so there are no interruptions when watching your child.

4.3 Charging

To charge the handset, connect the small plug located at the end of the power adaptor to the handset and the other end of the power adapter to the wall.

With the handset now plugged into the wall, notice the Power battery icon on the upper right-hand of the screen will display a charging animation. This indicates the handset is charging. When the handset is completely charged, the battery indicator shown on the screen will be full.

4.4 Pairing your Handset & Camera

By default, the camera and the handset comes paired. The pairing indicated is used to show the status of the connectivity between the handset and a camera.

- 1 Begin by placing the camera and handset near each other to ensure communication is optimal when pairing.
- 2 Ensure the camera is connected to power and the power switch is in the "On" Position. Also, ensure that the handset is either connected to power or has a charged battery.
- 3 On the bottom of the camera, press and hold the circular "Pair" button until the Night Light on the front of the camera start to flash rapidly. Now the camera is in pairing mode.
- 4 With the camera handset On, press the button and navigate to the camera setting menu. This menu is depicted with an icon that shows a camera and a gear.

- 5 Navigate to "add" and select the channel to add the camera.
- 6 Press the button and the Pairing indicator will begin to rapidly flash. This rapid flashing indicates that the device is waiting to be paired with the camera.
- 7 Now the camera is paired with the handset.
- 8 To view the camera picture, please back out of the menu and hold the key for two seconds to engage the alternate function for the handset keys.
- 9 Then press the camera switch/scan key to the bottom right of the handset face to change the camera channels.

Note

- › If the camera did not pair, please repeat the steps listed above.
- › There will be 15 seconds of allotted time for the handset and camera to establish the connection. If this time expires, the pairing process must be started over again.

The indicator will remain unlit when viewing the camera during normal operation of the handset. This indicated the camera channel is properly paired. The indicator will slowly flash if signal is lost when camera and handset are paired. Please move closer to the camera to reconnect. If the camera and handset do not automatically reconnect, check the camera to ensure it is properly powered. The camera may need to be repaired to the handset in some cases.

4.5 Wall Mounting The Camera Unit

Note

- Before installing the camera on the wall, it is important to test the reception of the handset to the camera.

Place the camera in the desired mounting area, then move around the home with the handset. If issues with signal loss occur, then reposition and test again.

- 1 Begin by drilling a pilot hole in the drywall of your home with a 3/16 inch (4.7mm) drill bit.
- 2 Insert the drywall anchor into the pilot hole. Tap

the anchor with a hammer to set it properly to seat the anchor.

- 3 Tighten the screw into the drywall anchor until the screw is sticking out of the wall about 1/8 of an inch. If needed, reverse the screw slightly so the camera fits easier on the screw.
- 4 Locate the hole on the bottom of the camera that is large enough for the screw head to fit. Note the hole tapers to a smaller notch.
- 5 Slide the camera over the screw and then down into the notched section of the hole. The camera should be snug against the wall after it's been slid down onto the screw. If the camera is not snug, then remove the camera from the screw, tighten the screw further into the wall, and replace the camera on the screw.
- 6 Plug the power adapter into the camera. Please do not have the power wire any closer than 3 feet from your child's crib or play area.

OPTIONAL:

Mount the wire to the wall by using cable raceway or clips. These are good solutions to ensure the cable is kept out of reach. Please note these are not included and are optional to the installation.

4.6 Charging

Connect the small plug located at the end of the power adaptor to the handset and the other end of the power adapter to the wall.

With the handset now plugged into the wall, notice that the battery icon on the upper right-hand corner of the screen will show a charging animation. This indicates the handset is charging. When the handset is completely charged, the animation will show the battery being full.

5 Using the Amcrest Care Monitor

5.1 Setting Up Your Camera

Consider the mounting options for using the camera. The camera can be mounted on a shelf or stand that is out of the reach of the child in care or a wall by drywall mounting. Once the camera has been placed or mounted, point the lens in the general direction of the child's area.

Note

Do not place the camera or power cable within reach of the child's area. The camera and cable may pose a threat to the child's health and should be kept no closer to three feet from the child's area.





5.2 Alternate Functions

Before proceeding in this section, note that the face keys on the handset have alternate functions. These functions are shown by the symbols and/or letter directly next to the button itself. Please see section 2.24 for the icon legend.

To enable the alternate functions of these buttons, press and hold the FN button until the  appears on the top of the display.

5.3 Pan and Tilt

The camera unit can be remotely controlled using the handset. The keys on the right side of the controller function as follows.



- 1 Press UP  button or DOWN  button to tilt the camera upward or downward.
- 2 Press the LEFT  and RIGHT  buttons to pan the camera left or right.

5.4 Night Vision

The camera has eight inferred LEDs that emit a nonvisible form of light which allows the camera to

see at night. The camera will automatically switch to night vision mode. When the light threshold is reached, a sensor will trigger night time viewing. A symbol of a moon in the upper bar will display on the handset. It is important to note the image will be in black and white as this is how inferred light functions.

5.5 Talk Mode



Press and hold the Talk  button on the handset to speak and be heard through the camera. When holding the talk  button, the talk icon will display on the handset's monitor. If the volume is turned up on the handset, sound is emitted and heard from the camera's location.

5.6 Sleep Mode

The parent handset unit has the ability to sleep so it saves battery and shuts off illumination while not in use. To manually set the handset in sleep mode, press the screen on/off button on the handset and immediately release it. While the device is sleeping, power will be consumed at a slower rate. While the handset is in sleep mode, audio will emit from the camera location until the VOX timer duration is met. Please see the following section for details of the VOX feature. As a safety precaution, when the screen is manually put to sleep and VOX is disabled sound will continue to be heard through the handset.





5.7 Screen Timer and VOX

VOX is a feature that allows the handset monitor to automatically sleep or standby when the sound volume at the camera location remains below a threshold. Once the threshold for sound volume is met, the handset monitor will turn on. The user will immediately be able to see and hear what is happening in the monitoring area. To configure this feature, please follow the steps below:

- 1 To configure this feature, press the menu  button.
- 2 Navigate to the VOX  icon.
- 3 Once highlighted, press the up  button on the handset until the appropriate sensitivity level is selected which is depicted by the circles displayed.

Sensitivity is represented in order of lowest to highest sensitivity via bottom to top.

Paired with this feature is the ability to control how long the screen will stay active once the VOX threshold has been met. To set the duration for the screen to remain active, please follow the steps below:







- 1 Navigate to the icon showing screen off timer.
- 2 Once this icon has been selected, press up and down  on the handset and select the desired duration of the screen to stay on.
- 3 For example, to activate the screen when softer sounds are detected and have the screen triggered stay on for one minute, navigate to the VOX  icon and press the up  arrow on the handset until all of the circles are blue.
- 4 Next, navigate to the screen off timer  icon and navigate to the 1 Min option.

Note



Please note that when VOX is disabled, you may still set screen timeout duration however, for safety audio captured by the camera may still be played unless the volume is turned completely down

5.8 Volume Control



There are two methods to reach the volume adjustments in the handset. Within the handset menu **MENU will be the volume  control.**

- 1 Once the menu is presented, press up  and down  on the direction pad to adjust the volume. Alternatively, also hold Function  key on the handset until the Fn icon appears on the handset screen.
- 2 Once Fn is shown on the handset screen, this means the alternate functions to the handset keys have been enabled.
- 3 Now press up  and down  on the handset to raise and lower the volume.
- 4 To disable the alternate handset functions, press and hold the  key for another two seconds.

5.9 Screen Brightness



- 1 To adjust the screen brightness, press the Menu **MENU** button.
- 2 Navigate to the brightness  icon and use the up  and down  arrows to adjust the brightness.
- 3 Once the brightness has been adjusted, press the menu **MENU** key again to exit.

5.10 Digital Zoom

- 1 To enable or disable the zoom, simply hold the Fn  key for two seconds to enable alternate handset key functions. The letters "Fn" will appear on the handset screen.
- 2 Now press the right arrow with the magnifying glass  icon to zoom in and out.
- 3 To disable alternate functions, press and hold the function key  for two seconds until the "Fn" icon is no longer on the monitor.



5.11 Adding and Removing Cameras

The Amcrest Care allows up to four cameras to be added to the handset. This section is useful if you purchased an add-on camera and wish to add or need to pair the camera to the handset again.

- 1 To add a camera, press the menu **MENU** button and navigate to the camera setup icon.
- 2 Once selected use the up  and down  arrow keys until "ADD" is highlighted and then press **OK** on the handset. A list of cameras will be presented showing Cam1, Cam2, Cam3, and Cam4. Cameras with an "*" asterisk next to them are already paired to the handset.
- 3 To add a camera, select an option that does not have an "*" asterisk and press "OK" on the handset.
- 4 Now the handset will be in pairing mode and the pairing indicator **pair** will flash rapidly. Located on the bottom of the camera is a button labeled "Pair".
- 5 Press and hold the Pair **pair** button until the light located on the front of the camera begins to flash.

Note

If the camera is not paired with handset within 20 seconds, the pairing procedure will be canceled and the process will need to be restarted.



- 1 To remove a camera, press the menu **MENU** button and navigate to the camera setup  icon.
- 2 Once selected use the up  and down  arrow keys until "DEL" is highlighted and then press **OK** on the handset. A list of cameras will be presented showing Cam1, Cam2, Cam3, and Cam4. Cameras with an "*" asterisk next to them are already paired to the handset.
- 3 Highlight the camera that must be removed and press **OK** on the handset.

Note

A camera unit may only be paired with one handset at a time.

5.12 Viewing Different Cameras

If more than one camera is paired to the handset, multiple feeds may be viewed.



- 1 Press and hold the **Fn** until the "Fn" appears on the screen.
- 2 Then press the Camera feed  button on the handset to change camera feeds. The camera feed you are in will display at the top of the screen.
- 3 To scan multiple feeds, press the camera feed  button on the handset until scan is shown. With scan selected, every 10 seconds another camera feed will be shown.
- 4 To disable camera scan, follow the previous directions until the preferred camera feed is shown.
- 5 Turn off the alternate functions by pressing and hold **Fn** until it is no longer shown on the monitor.

5.13 Lullaby

Included as a feature of the handset is the ability to play lullabies at the camera unit.



- 1 To play the lullabies press menu **MENU** and

navigate to the lullaby icon 

- 2 Once highlighted use the up  and down  arrow keys to select a song to play.
- 3 To have the song turned off, navigate to Off, and close the menu by pressing the menu **MENU** button again.



5.14 Nightlight

On the front of the camera unit is a nightlight that may be enabled.

- 1 Press the menu **MENU** button and navigating to the nightlight icon .
- 2 Once highlighted use the up  and down  arrow keys to select the either On or Off.
- 3 To close the menu, press the menu **MENU** button once again.

5.15 Temperature Display

Located in the menu of the handset is the ability to set the preferred temperature standard.

To set the temperature standard, please press the menu **MENU** key and navigate temperature unit of measurement selection  option . Use the up  and down  arrow keys.

Troubleshooting

Device does not turn on:

- › Confirm the camera and monitor unit are both ON (check Power LED indicator).
- › Check that both handset and camera units are charged or plugged into a charger.
- › Battery may be depleted and may need to be recharged or replaced.
- › Check that power adapters are connected correctly.

"Out of Range" displaying on handset unit:

- › Move the handset closer to the camera unit.
- › Pair the camera to the handset unit.
- › Reset both units by disconnecting them from battery and electrical power. Wait about 15 seconds then reconnect and pair.
- › Large metallic objects including mirrors, doors, refrigerators, fillings cabinets, may also block radio signal if it is between the two units.
- › Signal strength may be reduced when in close proximity to radio or other electrical equipment such as TVs, computers, phones, fluorescent light, or dimmer switches.
- › Use of 2.4Hz product such as WiFi routers, Bluetooth systems, or microwave ovens may cause interference. Keep camera and handset units at least 5ft from these items or turn them off.

Reception Interference:

- › The camera and handset units may be too far apart. Move the handset unit closer to the camera unit.
- › The battery power may be too low.
- › Check for interference from other electronic devices.
- › Handset and camera unit may be too close in proximity to large metallic objects causing interference.
- › Use of 2.4Hz product such as WiFi routers, Bluetooth systems, or microwave ovens may cause interference. Keep camera and handset units at least 5ft from these items or turn them off.

High pitched noise from handset unit:

- › Increase the distance between the handset and camera unit.
- › Volume may be too high. Reduce the volume on the handset unit.
- › Camera unit may be too far from the handset unit. Move the camera unit closer to the handset unit.
- › Make sure camera and handset units are placed away from other electrical equipment, such as television, computer, or phone.

No image from camera unit:

- › Check connection to the camera. Confirm the adapter is plugged in.
- › Recharge camera unit or replace the battery pack
- › Confirm that camera and handset unit are both on.

Picture is not smooth:

- › Move the camera unit closer to the handset unit.
- › Remove obstructions between the units.
- › Adjust the monitor antenna to vertical position
- › Use of 2.4Hz product such as WiFi routers, Bluetooth systems, or microwave ovens may cause interference. Keep camera and handset units at least 5ft from these items or turn them off.

Pairing Failed:

- › Confirm that the camera unit is turned on (power LED indicator shows green light).
- › Ensure power adapter is connected to the camera unit.
- › Test pairing to another camera channel.

Amber power LED flashing:

- › Battery level is low. Charge the handset unit.
Picture, but no sound:
- › Volume setting may be too low. Adjust to a higher setting.
Picture is in black and white:
- › Nightlight may be on. Nightlight operates in black and white.
- › Turn room lights on to force monitor out of night light mode.

Battery not charging:

- › Check that the battery is connected to the battery connection in the battery compartment.
- › The battery may need to be replaced due to everyday usage after a long period of time.

Handset shows HH instead

- › The Handset is meant to display temperatures up to 85 F /29 C. Above this range the handset will show "H H" to indicate there is high heat in the room.

No picture after 10 seconds:

- › VOX function is activated. Turn off VOX if required.

FCC Statement

1. This device complies with Part 15 of the FCC Rules. Operation is subject to the following two conditions:

- (1) This device may not cause harmful interference.
- (2) This device must accept any interference received, including interference that may cause undesired operation.

2. Changes or modifications not expressly approved by the party responsible for compliance could void the user's authority to operate the equipment.

NOTE:

This equipment has been tested and found to comply with the limits for a Class B digital device, pursuant to Part 15 of the FCC Rules. These limits are designed to provide reasonable protection against harmful interference in a residential installation.

This equipment generates uses and can radiate radio frequency energy and, if not installed and used in accordance with the instructions, may cause harmful interference to radio communications. However, there is no guarantee that interference will not occur in a particular installation. If this equipment does cause harmful interference to radio or television reception, which can be determined by turning the equipment off and on, the user is encouraged to try to correct the interference by one or more of the following measures:

Reorient or relocate the receiving antenna.

Increase the separation between the equipment and receiver.

Connect the equipment into an outlet on a circuit different from that to which the receiver is connected.

Consult the dealer or an experienced radio/TV technician for help.