

TEST REPORT

of

FCC Part 15 Subpart C

New Application; Change ID Application; Class II PC

Product : 7 inch Android Panel PC PoE LED
Brand: ProDVX
Model: APPC-7XPL, APPC-7XPLN
Model Difference: For different markets
FCC ID: 2AR42APPC7XPL
FCC Rule Part: §15.225, Cat: DXX
Applicant: ProDVX Europe B.V.
Address: Europalaan 12F, 5232 BC Den Bosch, The Netherlands

Test Performed by:
International Standards Laboratory Corp.

<LT Lab.>

*Site Registration No.

BSMI: SL2-IN-E-0013; MRA TW0997; TAF: 0997; IC: IC4067B-4;

*Address:

No. 120, Lane 180, Hsin Ho Rd., Lung-Tan Dist., Tao Yuan City 325, Taiwan

TEL: +886-3-263-8888 FAX: +886-3-263-8899

Report No.: **ISL-20LR400FC**

Issue Date : **2021/01/15**

Test results given in this report apply only to the specific sample(s) tested and are traceable to national or international standard through calibration of the equipment and evaluating measurement uncertainty herein.

The uncertainty of the measurement does not include in consideration of the test result unless the customer required the determination of uncertainty via the agreement, regulation or standard document specification.

This test report shall not be reproduced except in full, without the written approval of International Standards Laboratory Corp.



VERIFICATION OF COMPLIANCE

Applicant: ProDVX Europe B.V.
Product Description: 7 inch Android Panel PC PoE LED
Brand Name: ProDVX
Model No.: APPC-7XPL, APPC-7XPLN
Model Difference: For different markets.
FCC ID: 2AR42APPC7XPL
Date of test: 2020/12/04 ~ 2021/01/14
Date of EUT Received: 2020/12/04

We hereby certify that:

All the tests in this report have been performed and recorded in accordance with the standards described above and performed by an independent electromagnetic compatibility consultant, International Standards Laboratory Corp.

The test results contained in this report accurately represent the measurements of the characteristics and the energy generated by sample equipment under test at the time of the test. The sample equipment tested as described in this report is in compliance with the limits of above standards.

Test By: Barry Lee Date: 2021/01/15

Barry Lee / Senior Engineer

Prepared By: Gigi Yeh Date: 2021/01/15

Gigi Yeh / Senior Engineer

Approved By: Jerry Liu Date: 2021/01/15

Jerry Liu / Associate Director

Version

Version No.	Date	Description
00	2021/01/15	Initial creation of document

Uncertainty of Measurement

Description Of Test	Uncertainty
Conducted Emission (AC power line)	2.586 dB
Field Strength of Spurious Radiation	<=30MHz: 2.96dB 30-1GHz: 4.22 dB 1-40 GHz: 4.08 dB
Conducted Power	2.412 GHz: 1.30 dB 5.805 GHz: 1.55 dB
Power Density	2.412 GHz: 1.30 dB 5.805 GHz: 1.67 dB
Frequency	0.0032%

Table of Contents

1	General Information	5
1.1	Product Description.....	5
1.2	Related Submittal(s) / Grant (s)	6
1.3	Test Methodology	6
1.4	Test Facility.....	6
1.5	Special Accessories	6
1.6	Equipment Modifications.....	6
2	System Test Configuration.....	7
2.1	EUT Configuration	7
2.2	EUT Exercise	7
2.3	Test Procedure.....	7
2.4	Limitation.....	8
2.5	Configuration of Tested System.....	10
3	Summary of Test Results.....	11
4	Description of test modes.....	11
5	Conducted Emissions Test	12
5.1	Measurement Procedure:.....	12
5.2	Test SET-UP (Block Diagram of Configuration)	12
5.3	Measurement Equipment Used:	12
5.4	Measurement Result:.....	13
6	Radiated Emission Test	15
6.1	Measurement Procedure.....	15
6.2	Test SET-UP (Block Diagram of Configuration)	15
6.3	Measurement Equipment Used:	16
6.4	Field Strength Calculation	16
6.5	Measurement Result.....	17
7	Frequency Tolerance	22
7.1	Measurement Procedure.....	22
7.2	Test SET-UP (Block Diagram of Configuration)	22
7.3	Measurement Equipment Used:	23
7.4	Measurement Results	23

1 General Information

1.1 Product Description

General:

Product Name	7 inch Android Panel PC PoE LED	
Brand Name	ProDVX	
Model Name	APPC-7XPL, APPC-7XPLN	
Model Difference	For different markets	
USB port	One provided	
Micro USB	One provided	
SD	One provided	
RJ45	One provided	
Audio ouy	One provided	
Power Supply	12Vdc from AC/DC adapter	
	Adapter:	<ol style="list-style-type: none"> 1. Model : SOY-1200200-068 2. Model: 2AAJ024FC 3. Model: 2ABL024F US

NFC:

Operating Frequency	13.56MHz
Transmit Power	53.98 dBuV/m Peak at 3m
Number of Channels	1
Antenna Type	Coil Antenna
Modulation Type	ASK

The Test report is applied for NFC.

Remark: The above DUT's information was declared by manufacturer. Please refer to the specifications or user's manual for more detailed description.

1.2 Related Submittal(s) / Grant (s)

This submittal(s) (test report) is intended for **FCC ID: 2AR42APPC7XPL** filing to comply with Section 15.225 of the FCC Part 15, Subpart C Rules.

1.3 Test Methodology

Both conducted and radiated testing were performed according to the procedures in ANSI 63.4: 2014. Radiated testing was performed at an antenna to EUT distance 3 meters. Radiated testing was performed at an antenna to EUT distance 3 meters.

1.4 Test Facility

The measurement facilities used to collect the 3m Radiated Emission and AC power line conducted data are located on the address of **International Standards Laboratory Corp.** <LT Lab.> No. 120, Lane 180, Hsin Ho Rd., Lung-Tan Dist., Tao Yuan City 325, Taiwan which are constructed and calibrated to meet the FCC requirements in documents ANSI 63.4: 2014. FCC Registration Number is: TW0997, Canada Registration Number: 4067B-4.

1.5 Special Accessories

Not available for this EUT intended for grant.

1.6 Equipment Modifications

Not available for this EUT intended for grant.

2 System Test Configuration

2.1 EUT Configuration

The EUT configuration for testing is installed on RF field strength measurement to meet the Commissions requirement and operating in a manner which intends to maximize its emission characteristics in a continuous normal application.

2.2 EUT Exercise

The EUT (Transmitter) was tested with a test program to fix the Tx frequency that was for the purpose of the measurements. For more information please see test data and APPENDIX 1 for set-up photographs.

2.3 Test Procedure

2.3.1 Conducted Emissions

The EUT is a placed on as turn table which is 0.8 m above ground plane. According to the requirements in Section 7 and 13 of ANSI C63.4: 2014. Conducted emissions from the EUT measured in the frequency range between 0.15 MHz and 30MHz using CISPR Quasi-Peak and Average detector mode.

2.3.2 Radiated Emissions

The EUT is a placed on as turn table which is 0.8 m/1.5m(Frequency above 1GHz) above ground plane. The turn table shall rotate 360 degrees to determine the position of maximum emission level. EUT is set 3m away from the receiving antenna which varied from 1m to 4m to find out the highest emission. And also, each emission was to be maximized by changing the polarization of receiving antenna both horizontal and vertical. In order to find out the max. emission, the relative positions of this hand-held transmitter (EUT) was rotated through three orthogonal axes according to the requirements in Section 6 and 11 of ANSI C63.10: 2013.

2.4 Limitation

(1) Conducted Emission

According to section 15.207(a) Conducted Emission Limits is as following.

Frequency range MHz	Limits dB (uV)	
	Quasi-peak	Average
0.15 to 0.50	66 to 56	56 to 46
0.50 to 5	56	46
5 to 30	60	50

Note

- 1.The lower limit shall apply at the transition frequencies
- 2.The limit decreases linearly with the logarithm of the frequency in the range 0.15 MHz to 0.50 MHz.

(2) Radiated Emission

1. The field strength of any emission within the band 13.553-13.567 MHz shall not exceed 15,848 microvolts/meter at 30 meters. (124dBuV/m at 3m)
2. Within the bands 13.410-13.553 MHz and 13.567-13.710 MHz, the field strength of any emissions shall not exceed 334 microvolts/meter at 30 meters. (90.47dBuV/m at 3m.)
3. Within the bands 13.110-13.410 MHz and 13.710-14.010 MHz the field strength of any emissions shall not exceed 106 microvolts/meter at 30 meters. (80.5dBuV/m at 3m.)
4. The field strength of any emissions appearing outside of the 13.110-14.010 MHz shall not exceed the general radiated emission limits in section 15.209(Intentional Radiators general limit).as below.

Frequency (MHz)	Field strength $\mu\text{V}/\text{m}$	Distance (m)	Field strength at 3m $\text{dB}\mu\text{V}/\text{m}$
1.705-30	30	2 30	69.54
30-88	100	3	40
88-216	150	3	43.5
216-960	200	3	46
Above 960	500	3	54

- Remark:
1. Emission level in dBuV/m= $20 \log (\mu\text{V}/\text{m})$
 2. Measurement was performed at an antenna to the closed point of EUT distance of meters.
 3. Only spurious frequency is permitted to locate within the Restricted Bands specified in provision of §15.205
 4. Emission spurious frequency which appearing within the Restricted Bands specified in provision of §15.205, then the general radiated emission limits in § 15.209 apply.
 - 5.

Limitation Calculation:

15,848 microvolts/meter at 30 meters = $20 \log (15,848)$ dBuV/m at 30m = 84 dBuV/m at 30m= 124 dBuV/m at 3m

30m to 3m distance correction factor: $40 \log (30/3) = 40 \text{ dB}$

(3) Frequency Tolerance

The frequency tolerance of the carrier signal shall be maintained within +/- 0.01% of the operating frequency over a temperature variation of -20 degrees to +50 degrees C at normal supply voltage, and for a variation in the primary supply voltage from 85% to 115% of the rated supply voltage at a temperature of 20 degrees C. For battery operated equipment, the equipment tests shall be performed using a new battery.

2.5 Configuration of Tested System

Fig. 2-1 Configuration of Tested System



Table 2-1 Equipment Used in Tested System

Item	Equipment	Mfr/Brand	Model/ Type No.	Series No.	Data Cable	Power Cord
1	Adaptor (EUT)	Shenzhen SOY Techology Co.,LTD	SOY-1200200- 068	NA	NA	3M

3 Summary of Test Results

FCC Rules	Description Of Test	Result
§ 15.207	Conducted Emission	Compliant
§ 15.225 (a)-(d)	Radiated Emission	Compliant
§ 15.225 (e)	Frequency Stability	Compliant

4 Description of test modes

The EUT was tested when placed vertically on the table and the EUT stay in continuous transmitting mode.

5 Conducted Emissions Test

5.1 Measurement Procedure:

1. The EUT was placed on a table which is 0.8m above ground plane.
2. Maximum procedure was performed on the six highest emissions to ensure EUT compliance.
3. Repeat above procedures until all frequency measured were complete.

5.2 Test SET-UP (Block Diagram of Configuration)

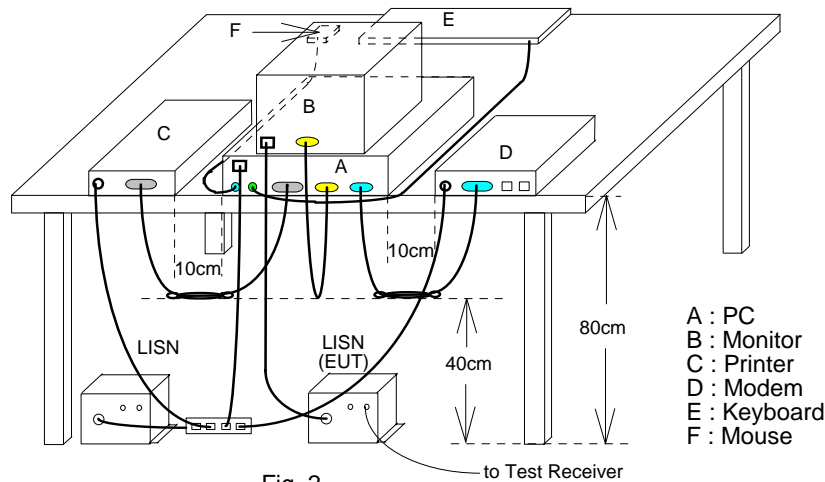

5.3 Measurement Equipment Used:

Location	Equipment Name	Brand	Model	S/N	Last Cal. Date	Next Cal. Date
Conduction 03	EMI Receiver 15	ROHDE & SCHWARZ	ESCI	101166	07/29/2020	07/29/2021
Conduction 03	ISN T4 09	Teseq GmbH	ISN T400A	49914	08/10/2020	08/10/2021
Conduction 03	ISNT8 09	Teseq GmbH	ISN T800	36190	09/20/2020	09/20/2021
Conduction 03	LISN 15	R&S	ENV216	101335	12/12/2020	12/12/2021
Conduction 03	LISN 22	R&S	ENV216	101478	08/10/2020	08/10/2021
Conduction 03	Conduction Cable 04-3	WOKEN	CFD 300-NL	conduction 04-3	08/29/2020	08/29/2021
Conduction 03	Capacitive Voltage Probe	FCC	F-CVP-1	68	01/17/2020	01/17/2021
Conduction 03	Current Probe	SCHAFFNER	SMZ 11	18030	01/17/2020	01/17/2021



Address: No. 120, Lane 180, Hsin Ho Rd., Lung-Tan Dist.,
Tao Yuan City 325, Taiwan.
Tel: 03-2638888

Conducted Emission Measurement

Date: 2020/12/21

operator: Jeff Liang

Temperature: 26 °C

Humidity: 60 %

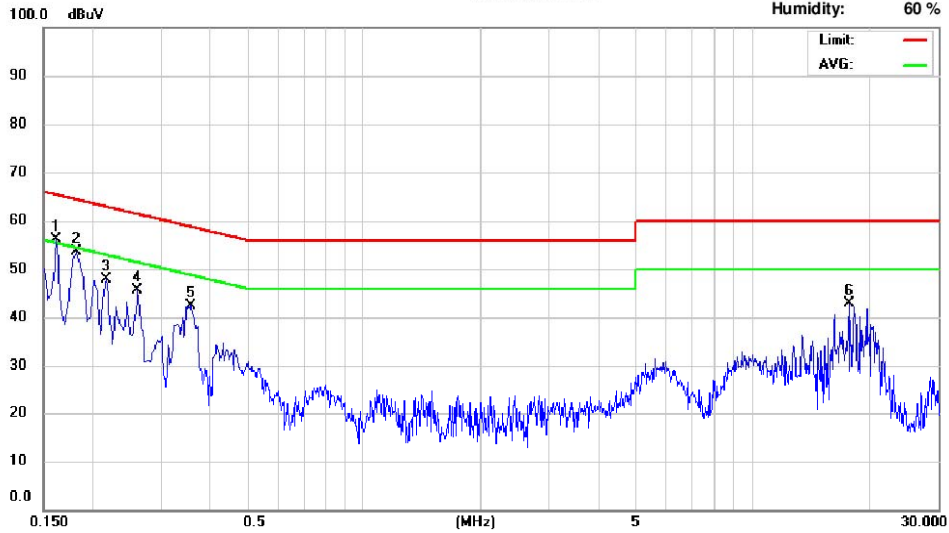

Site: Conduction 03

Phase: N

No.	Frequency (MHz)	QP_R (dBuV)	AVG_R (dBuV)	Correct Factor (dB)	QP Emission (dBuV)	QP Limit (dBuV)	QP Margin (dB)	AVG Emission (dBuV)	AVG Limit (dBuV)	AVG Margin (dB)
1	0.162	43.36	28.85	9.71	53.07	65.36	-12.29	38.56	55.36	-16.80
2	0.182	39.66	24.27	9.70	49.36	64.39	-15.03	33.97	54.39	-20.42
3	0.218	34.58	20.84	9.71	44.29	62.89	-18.60	30.55	52.89	-22.34
4	0.262	30.49	18.30	9.71	40.20	61.37	-21.17	28.01	51.37	-23.36
5	0.358	31.58	24.31	9.70	41.28	58.77	-17.49	34.01	48.77	-14.76
6	17.694	31.29	28.49	10.02	41.31	60.00	-18.69	38.51	50.00	-11.49

6 Radiated Emission Test

6.1 Measurement Procedure

1. The EUT was placed on a turn table which is 0.8m above ground plane.
2. Maximum procedure was performed on the six highest emissions to ensure EUT compliance.
3. And also, each emission was to be maximized by changing the polarization of receiving antenna both horizontal and vertical.
4. Repeat above procedures until all frequency measured were complete.

6.2 Test SET-UP (Block Diagram of Configuration)

(A) Radiated Emission Test Set-Up, Frequency Below 30MHz

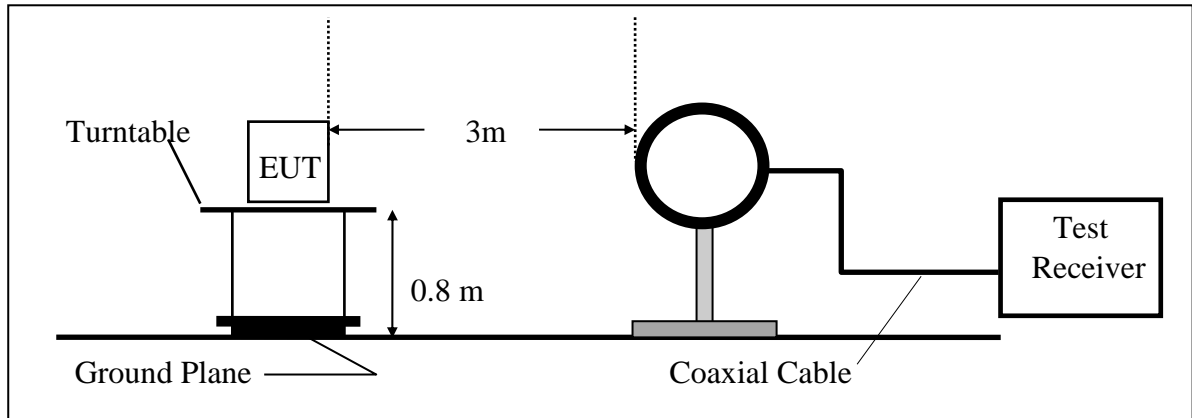

(B) Radiated Emission Test Set-Up, Frequency Below 1000MHz

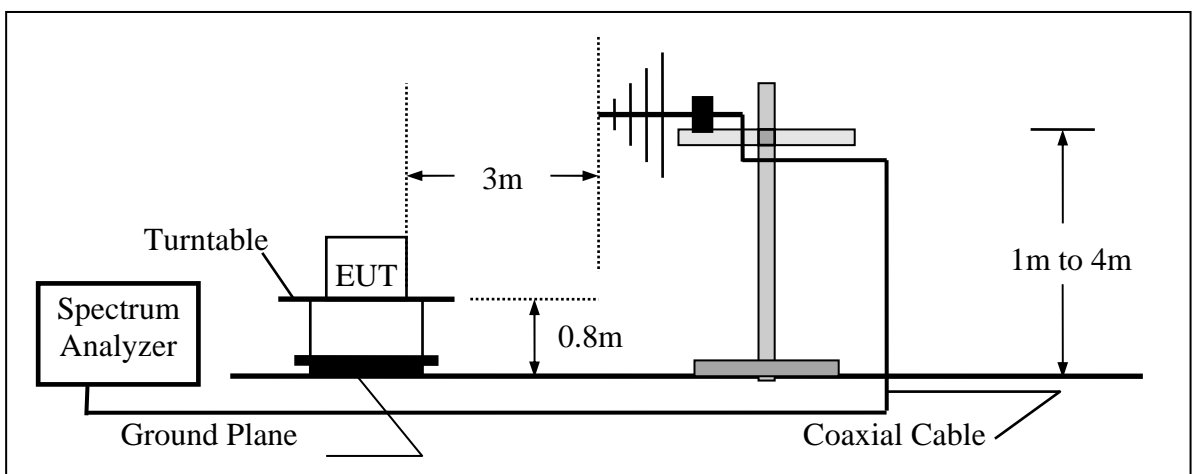

6.3 Measurement Equipment Used:

Location Conducted	Equipment Name	Brand	Model	S/N	Last Cal. Date	Next Cal. Date
Chamber 19	Signal analyzer	R&S	FSV40	101919	8/13/2020	8/13/2021
Chamber 19	EMI Receiver	R&S	ESR3	102461	05/05/2020	05/05/2021
Chamber 19	Loop Antenna	EM	EM-6879	271	05/21/2020	05/21/2021
Chamber 19	Bilog Antenna (30MHz-1GHz)	Schwarzbeck	VULB9168 w 6dB Att.	736	02/11/2020	02/11/2021
Chamber 19	Horn antenna (1GHz-18GHz)	ETS LINDGREN	3117	00218718	09/25/2020	09/25/2021
Chamber 19	Horn antenna (18GHz-26GHz)	Com-power	AH-826	081001	11/23/2020	11/23/2021
Chamber 19	Horn antenna (26GHz-40GHz)	Com-power	AH-640	100A	03/13/2020	03/13/2021
Chamber 19	Preamplifier (9kHz-1GHz)	HP	8447F	3113A04621	06/19/2020	06/19/2021
Chamber 19	Preamplifier (1GHz - 26GHz)	EM	EM01M26G	060681	05/04/2020	05/04/2021
Chamber 19	Preamplifier (26GHz-40GHz)	MITEQ	JS4-26004000-27-5A	818471	05/04/2020	05/04/2021
Chamber 19	RF Cable (9kHz-18GHz)	Huber Suhner & Woken	Sucoflex 104A & 18GHz SMA(M)-SMA(M)-10M	MY817/4A & 20200525	12/25/2020	12/25/2021
Chamber 19	RF Cable (18GHz-40GHz)	HUBER SUHNER	Sucoflex 102	27963/2&37421/2	11/19/2020	11/19/2021
Chamber 19	Signal Generator	Anritsu	MG3692A	20311	01/03/2021	01/03/2022
Chamber 19	Test Software	Audix	E3 Ver:6.12023	N/A	N/A	N/A

6.4 Field Strength Calculation

The field strength is calculated by adding the Antenna Factor and Cable Factor and subtracting the Amplifier Gain and Duty Cycle Correction Factor (if any) from the measured reading. The basic equation with a sample calculation is as follows:

$$FS = RA + AF + CL - AG$$

Where	FS = Field Strength	CL = Cable Attenuation Factor (Cable Loss)
	RA = Reading Amplitude	AG = Amplifier Gain
	AF = Antenna Factor	

6.5 Measurement Result

Fundamental Measurement Result

Operation Mode	: TX mode	Test Date	: 2021/01/07
Fundamental Frequency	: 13.56 MHz	Test By	: Barry
Temp	: 25 °C	Hum.	: 60%

Freq MHz	Reading dBuV	Factor dB/m	Level dBuV/m	Limit dBuV/m	Margin dB	Remark	Pol V/H
13.56	42.98	11.00	53.98	124.00	-70.02	Peak	VERTICAL
13.56	35.98	11.00	46.98	124.00	-77.02	Peak	HORIZONTAL

Radiated Mask

Fundamental Measurement Result

Operation Mode : MASK
 Fundamental Frequency : 13.56 MHz
 Temp : 25 °C

Test Date : 2021/01/07
 Test By : Barry
 Hum. : 60%

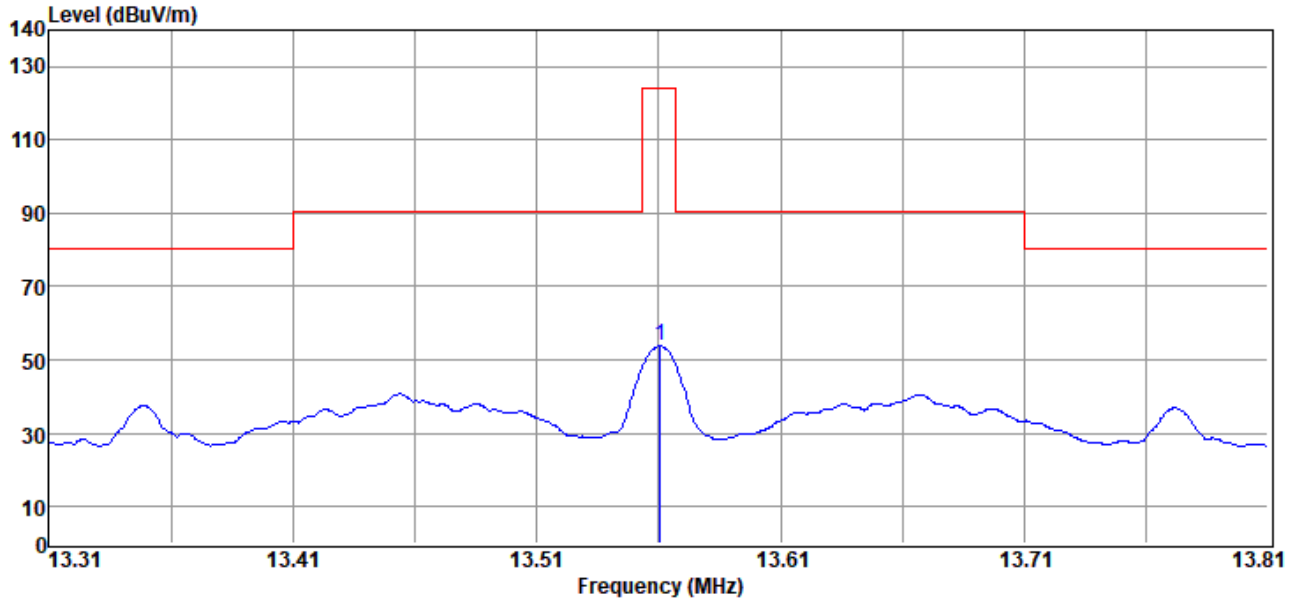

No	Freq MHz	Reading dBuV	Factor dB/m	Level dBuV/m	Limit dBuV/m	Margin dB	Remark	Pol V/H
1	13.56	42.79	11.00	53.79	124.00	-70.21	Peak	VERTICAL

Operation Mode : MASK
 Fundamental Frequency : 13.56 MHz
 Temp : 25 °C

Test Date : 2021/01/07
 Test By : Barry
 Hum. : 60%

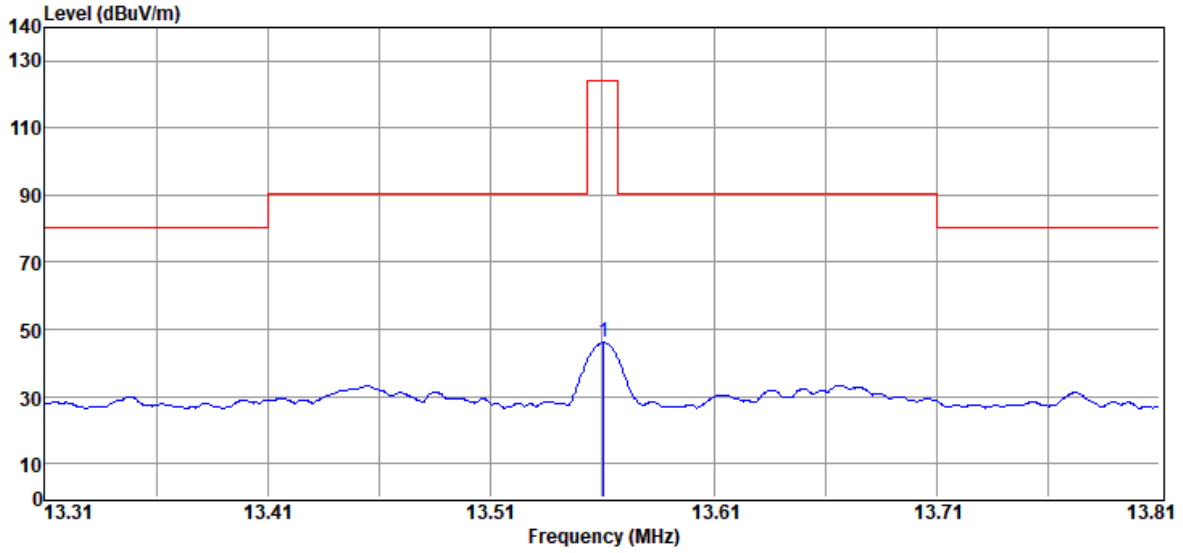

No	Freq MHz	Reading dBuV	Factor dB/m	Level dBuV/m	Limit dBuV/m	Margin dB	Remark	Pol V/H
1	13.56	35.15	11.00	46.15	124.00	-77.85	Peak	HORIZONTAL

Radiated Spurious Emission Measurement Result (below 1GHz)

Operation Mode:	Transmitting Mode	Test Date:	2021/01/07
Fundamental Frequency:	13.56MHz	Test By:	Barry
Temperature :	25 °C	Humidity :	65 %

1	0.73	45.49	16.57	62.06	71.02	-8.96	Peak	HORIZONTAL
2	4.66	26.16	10.45	36.61	69.54	-32.93	Peak	HORIZONTAL
3	9.82	27.64	11.40	39.04	69.54	-30.50	Peak	HORIZONTAL
4	17.25	31.56	10.68	42.24	69.54	-27.30	Peak	HORIZONTAL
5	22.44	28.71	11.33	40.04	69.54	-29.50	Peak	HORIZONTAL
6	27.12	28.73	12.75	41.48	69.54	-28.06	Peak	HORIZONTAL
7	149.31	39.56	-5.03	34.53	43.50	-8.97	Peak	HORIZONTAL
8	203.63	42.84	-7.40	35.44	43.50	-8.06	Peak	HORIZONTAL
9	256.98	39.22	-5.45	33.77	46.00	-12.23	Peak	HORIZONTAL
10	515.00	35.27	-0.31	34.96	46.00	-11.04	Peak	HORIZONTAL
11	600.36	41.80	1.58	43.38	46.00	-2.62	Peak	HORIZONTAL
12	900.09	38.58	6.17	44.75	46.00	-1.25	Peak	HORIZONTAL

Remark:

- 1 No further spurious emissions detected from the lowest internal frequency and 30MHz.
- 2 Measuring frequencies from the lowest internal frequency to the 1GHz.
- 3 Radiated emissions measured in frequency range from 30 MHz to 1000MHz were made with an instrument using Peak / QP detector mode.
- 4 Measurement result within this frequency range shown “ - ” in the table above means the reading of emissions are attenuated more than 20dB below the permissible limits or the field strength is too small to be measured.
- 5 The IF bandwidth of SPA between 30MHz to 1GHz was 100kHz, VBW=300kHz.
- 6 Peak is below the average limit, so that the average result is not measured

7 Frequency Tolerance

7.1 Measurement Procedure

1. The EUT was placed on a turn table which is 0.8m above ground plane.
2. Set EUT as normal operation
3. Set SPA Center Frequency = fundamental frequency, RBW, VBW= 10kHz, Span =100kHz.
4. Set SPA Max hold. Mark peak.
- 5.

7.2 Test SET-UP (Block Diagram of Configuration)

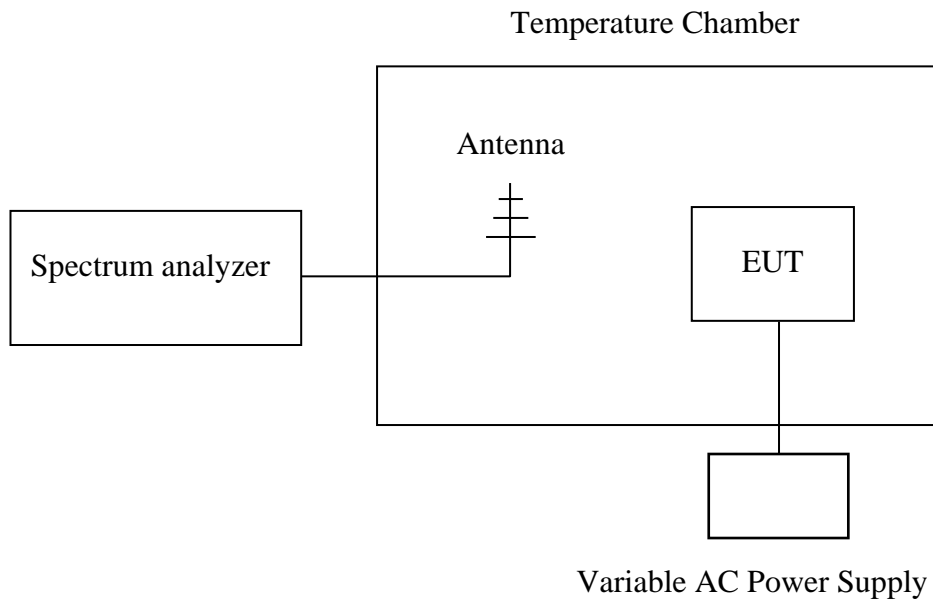

7.3 Measurement Equipment Used:

Location Conducted	Equipment Name	Brand	Model	S/N	Last Cal. Date	Next Cal. Date
Conducted	Power Meter	Anritsu	ML2495A	1116010	09/25/2020	09/25/2021
Conducted	Power Sensor	Anritsu	MA2411B	34NKF50	09/25/2020	09/25/2021
Conducted	Power Sensor	DARE	RPR3006W	13I00030SNO33	01/03/2020	01/03/2021
Conducted	Power Sensor	DARE	RPR3006W	13I00030SNO34	01/09/2020	01/09/2021
Conducted	Power Sensor	DARE	RPR3006W	14I00889SNO35	06/29/2020	06/29/2021
Conducted	Power Sensor	DARE	RPR3006W	14I00889SNO36	06/29/2020	06/29/2021
Conducted	Temperature Chamber	KSON	THS-B4H100	2287	03/11/2020	03/11/2021
Conducted	DC Power supply	ABM	8185D	N/A	01/03/2020	01/03/2021
Conducted	AC Power supply	EXTECH	CFC105W	NA	N/A	N/A
Conducted	Spectrum analyzer	Keysight	N9010A	MY56070257	09/23/2020	09/23/2021
Conducted	Spectrum analyzer	R&S	FSP40	100116	01/10/2020	01/10/2021
Conducted	Test Software	DARE	Radiation Ver:2013.1.23	NA	NA	NA
Conducted	Test Software	R&S	CMUGO Ver:2.0.0	N/A	N/A	N/A
Conducted	Radio Communication Analyzer	R&S	CMU200	111968	11/29/2020	11/29/2021
Conducted	Wideband Radio Communication Tester	R&S	CMW500	1201.002K50108793-JG	10/28/2020	10/28/2021
Conducted	BT Simulator	Agilent	N4010A	MY48100200	NA	NA
Conducted	GPS Simulator	Welnavigate	GS-50	701523	NA	NA

7.4 Measurement Results

Refer to attached data chart.

A. Temperature Variation

Limit: +/- 0.01%					
Power Supply	Environment	Frequency	Delta (KHz)	Limit (KHz)	Result
Vdc	Temperature (°C)	(MHz)			
12	-20	13.56044	-0.010	1.356	Pass
	-10	13.56048	0.030		Pass
	0	13.56047	0.020		Pass
	10	13.56049	0.040		Pass
	20	13.56045	0.000		Pass
	30	13.56043	-0.020		Pass
	40	13.56046	0.010		Pass
	50	13.56049	0.060		Pass
	60	13.56048	0.030		Pass

B. Supply Voltage Variation

Limit: +/- 0.01%					
Power Supply	Environment	Frequency	Delta (KHz)	Limit (KHz)	Result
Vdc	Temperature (°C)	(MHz)			
12	20	13.56045	0.000	1.356	Pass
13.2	20	13.56047	0.020		Pass
10.8	20	13.56048	0.030		Pass