

FCC&IC RADIO TEST REPORT

FCC ID: 2AR3Z-UNA
IC: 24615-UNA

Product : Portable Speaker

Trade Name : POW AUDIO INC

Model Name : POW Una

Serial Model : N/A

Report No. : UNIA19112102FR-01

Prepared for

POW AUDIO INC

116 John Street, Suite 415, Lowell, MA 01582, USA

Prepared by

Shenzhen United Testing Technology Co., Ltd.

2F, Annex Bldg, Jiahuangyuan Tech Park, #365 Baotian 1 Rd, Tiegang Community, Xixiang Str, Bao'an District, Shenzhen, China

TEST RESULT CERTIFICATION

Applicant's name : POW AUDIO INC
Address : 116 John Street, Suite 415, Lowell, MA 01582, USA
Manufacture's Name..... : POW AUDIO INC
Address : 116 John Street, Suite 415, Lowell, MA 01582, USA

Product description

Product name : Portable Speaker
Trade Mark : POW AUDIO INC
Model and/or type reference : POW Una
 FCC Rules and Regulations Part 15 Subpart C Section 15.247

Standards : ANSI C63.10: 2013 , RSS-247 Issue 2: February 2017,
 RSS-Gen Issue 5: March 2019

This device described above has been tested by Shenzhen United Testing Technology Co., Ltd., and the test results show that the equipment under test (EUT) is in compliance with the FCC requirements. And it is applicable only to the tested sample identified in the report.

This report shall not be reproduced except in full, without the written approval of UNI, this document may be altered or revised by Shenzhen United Testing Technology Co., Ltd., personnel only, and shall be noted in the revision of the document.

Date of Test :
Date (s) of performance of tests : 2019-10-31 ~ 2019-11-14
Date of Issue..... : 2019-11-19
Test Result..... : Pass

Prepared by:

Kahn Yang

Kahn Yang/Editor

Reviewer:

Sherwin Chan
 Sherwin Chan/Supervisor

Approved & Authorized Signer:

Liuze

Liuze/Manager

Table of Contents

Page

1 . TEST SUMMARY	1
2 . GENERAL INFORMATION	1
2.1 GENERAL DESCRIPTION OF EUT	1
2.2 Carrier Frequency of Channels	1
2.3 Operation of EUT during testing	1
2.4 DESCRIPTION OF TEST SETUP	1
2.5 MEASUREMENT INSTRUMENTS LIST	1
3 . CONDUCTED EMISSIONS TEST	1
3.1 Conducted Power Line Emission Limit	11
3.2 Test Setup	11
3.3 Test Procedure	11
3.4 Test Result	11
4 RADIATED EMISSION TEST	14
4.1 Radiation Limit	14
4.2 Test Setup	14
4.3 Test Procedure	15
4.4 Test Result	15
5 BAND EDGE	21
5.1 Limits	21
5.2 Test Procedure	21
5.3 Test Result	21
6 OCCUPIED BANDWIDTH MEASUREMENT	26
6.1 Test Limit	26
6.2 Test Procedure	26
6.3 Measurement Equipment Used	26
6.4 Test Result	26
7 POWER SPECTRAL DENSITY TEST	31
7.1 Test Limit	31
7.2 Test Procedure	31
7.3 Measurement Equipment Used	31
7.4 Test Result	31
8 PEAK OUTPUT POWER TEST	34
8.1 Test Limit	34
8.2 Test Procedure	34

Table of Contents	Page
8.3 Measurement Equipment Used	34
8.4 Test Result	34
9 OUT OF BAND EMISSIONS TEST	35
9.1 Test Limit	35
9.2 Test Procedure	35
9.3 Test Setup	35
9.4 Test Result	35
10 ANTENNA REQUIREMENT	37

1. TEST SUMMARY

1.1 TEST PROCEDURES AND RESULTS

DESCRIPTION OF TEST	STANDARD	RESULT
6dB Bandwidth And 99% Occupied Bandwidth	FCC Part 15.247 (a)(2) RSS-Gen clause 6.7 &RSS-247 5.2 a)	COMPLIANT
Peak Output Power	FCC Part 15.247(b)(3) RSS-Gen clause 6.12 &RSS-247 5.4 d)	COMPLIANT
Power Spectral Density	FCC Part 15.247(e) RSS-247 5.2 b) & ANSIC63.10: Clause 12.5	COMPLIANT
Spurious Emissions at Antenna Port	FCC Part 15.247(d)& RSS-247 5.5	COMPLIANT
Spurious Emissions	FCC Part 15.205, 15.209,FCC Part 15.247(d) RSS-Gen 8.9 8.10	COMPLIANT
100 kHz Bandwidth of Frequency Band Edge	FCC Part 15.205, 15.209,FCC Part 15.247(d) RSS-Gen 8.9 8.10	COMPLIANT
AC Line Conducted Emissions	FCC Part 15.207 (a) RSS-Gen clause 8.8	COMPLIANT
Antenna requirement	FCC Part 15: 15.203 RSS-Gen clause 6.8	COMPLIANT

1.2 TEST FACILITY

Test Firm : Shenzhen United Testing Technology Co., Ltd.
 Address : 2F, Annex Bldg, Jiahuangyuan Tech Park, #365 Baotian 1 Rd, Tiegang Community, Xixiang Str, Bao'an District, Shenzhen, China

The testing quality ability of our laboratory meet with "Quality Law of People's Republic of China" Clause 19.The testing quality system of our laboratory meets with ISO/IEC-17025 requirements, which is approved by CNAS. This approval result is accepted by MRA of APLAC.

Our test facility is recognized, certified, or accredited by the following organizations:

CNAS-LAB Code: L6494

The EMC Laboratory has been assessed and in compliance with CNAS-CL01 accreditation criteria for testing Laboratories (identical to ISO/IEC 17025:2017 General Requirements) for the Competence of testing Laboratories.

Designation Number: CN1227

Test Firm Registration Number: 674885

The EMC Laboratory has been registered and fully described in a report filed with the (FCC) Federal Communications commission. The acceptance letter from the FCC is maintained in our files.

Measurement Uncertainty

Conducted Emission Expanded Uncertainty	=	2.23dB, k=2
Radiated emission expanded uncertainty(9kHz-30MHz)	=	3.08dB, k=2
Radiated emission expanded uncertainty(30MHz-1000MHz)	=	4.42dB, k=2
Radiated emission expanded uncertainty(Above 1GHz)	=	4.06dB, k=2

2. GENERAL INFORMATION

2.1 GENERAL DESCRIPTION OF EUT

Equipment	Portable Speaker
Trade Mark	POW AUDIO INC
Model Name	POW Una
Serial No.	N/A
Model Difference	N/A
FCC ID IC	2AR3Z-UNA 24615-UNA
Antenna Type	PCB Antenna
Antenna Gain	0dBi
Frequency Range	2402 MHz to 2480 MHz
Number of Channels	40
Modulation Type	GFSK
Battery	N/A
Power Source	DC 5V from adapter or DC 7.4V from battery
Adapter	N/A

2.2 Carrier Frequency of Channels

Description of Channel:			
Channel	Frequency (MHz)	Channel	Frequency (MHz)
00	2402	20	2442
01	2404	21	2444
02	2406	22	2446
03	2408	23	2448
04	2410	24	2450
05	2412	25	2452
06	2414	26	2454
07	2416	27	2456
08	2418	28	2458
09	2420	29	2460
10	2422	30	2462
11	2424	31	2464
12	2426	32	2466
13	2428	33	2468
14	2430	34	2470
15	2432	35	2472
16	2434	36	2474
17	2436	37	2476
18	2438	38	2478
19	2440	39	2480

2.3 Operation of EUT during testing

Operating Mode

Test software Version: ATS282X FCC Test tools v1.09

Power Parameters: default setting

The mode is used:

Transmitting mode for TX 1Mbps Mode

Low Channel: 2402MHz

Middle Channel: 2440MHz

High Channel: 2480MHz

2.4 DESCRIPTION OF TEST SETUP

Operation of EUT during Conducted testing:

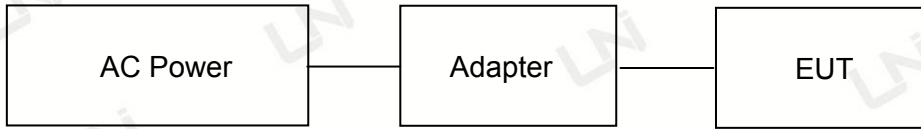

Operation of EUT during Radiation and Above1GHz Radiation testing:



Table for auxiliary equipment:

Equipment Description	Manufacturer	Model	Calibration Due Date
N/A	N/A	N/A	N/A
N/A	N/A	N/A	N/A

2.5 MEASUREMENT INSTRUMENTS LIST

Item	Equipment	Manufacturer	Model No.	Serial No.	Calibrated until
CONDUCTED EMISSIONS TEST					
1	AMN	Schwarzbeck	NNLK8121	8121370	2020.9.9
2	AMN	ETS	3810/2	00020199	2020.9.9
3	EMI TEST RECEIVER	Rohde&Schwarz	ESCI	101210	2020.9.9
4	AAN	TESEQ	T8-Cat6	38888	2020.9.9
RADIATED EMISSION TEST					
1	Horn Antenna	Sunol	DRH-118	A101415	2020.9.9
2	BicoNILog Antenna	Sunol	JB1 Antenna	A090215	2020.9.9
3	PREAMP	HP	8449B	3008A00160	2020.9.9
4	PREAMP	HP	8447D	2944A07999	2020.9.9
5	EMI TEST RECEIVER	Rohde&Schwarz	ESR3	101891	2020.9.9
6	VECTOR Signal Generator	Rohde&Schwarz	SMU200A	101521	2020.9.28
7	Signal Generator	Agilent	E4421B	MY4335105	2020.9.28
8	MXA Signal Analyzer	Agilent	N9020A	MY50510140	2020.9.28
9	MXA Signal Analyzer	Agilent	N9020A	MY51110104	2020.9.9
10	ANT Tower&Turn table Controller	Champro	EM 1000	60764	2020.9.28
11	Anechoic Chamber	Taihe Maorui	9m*6m*6m	966A0001	2020.9.9
12	Shielding Room	Taihe Maorui	6.4m*4m*3m	643A0001	2020.9.9
13	RF Power sensor	DARE	RPR3006W	15I00041SNO88	2020.3.14
14	RF Power sensor	DARE	RPR3006W	15I00041SNO89	2020.3.14
15	RF power divider	Anritsu	K241B	992289	2020.9.28
16	Wideband radio communication tester	Rohde&Schwarz	CMW500	154987	2020.9.28
17	Biconical antenna	Schwarzbeck	VHA 9103	91032360	2020.9.8
18	Biconical antenna	Schwarzbeck	VHA 9103	91032361	2020.9.8
19	Broadband Hybrid Antennas	Schwarzbeck	VULB9163	VULB9163#958	2020.9.8
20	Horn Antenna	Schwarzbeck	BBHA9120D	9120D-1680	2020.1.12
21	Active Receive Loop Antenna	Schwarzbeck	FMZB 1919B	00023	2020.9.8
22	Horn Antenna	Schwarzbeck	BBHA 9170	BBHA9170651	2020.03.14
23	Microwave Broadband Preamplifier	Schwarzbeck	BBV 9721	100472	2020.9.8
24	Active Loop Antenna	Com-Power	AL-130R	10160009	2020.05.10
25	Power Meter	KEYSIGHT	N1911A	MY50520168	2020.05.10
26	Frequency Meter	VICTOR	VC2000	997406086	2020.05.10
27	DC Power Source	HYELEC	HY5020E	055161818	2020.05.10

3. CONDUCTED EMISSIONS TEST

3.1 Conducted Power Line Emission Limit

For unintentional device, according to § 15.107(a) Line Conducted Emission Limits is as following

Frequency (MHz)	Maximum RF Line Voltage(dB V)			
	CLASS A		CLASS B	
	Q.P.	Ave.	Q.P.	Ave.
0.15~0.50	79	66	66~56*	56~46*
0.50~5.00	73	60	56	46
5.00~30.0	73	60	60	50

* Decreasing linearly with the logarithm of the frequency

For intentional device, according to §15.207(a) Line Conducted Emission Limit is same as above table.

3.2 Test Setup

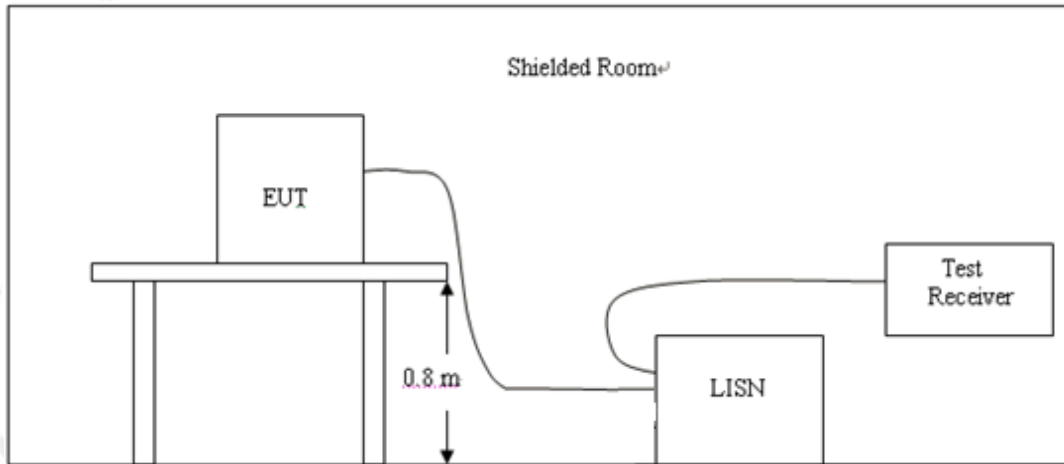

3.3 Test Procedure

- 1, The equipment was set up as per the test configuration to simulate typical actual usage per the user's manual. A wooden table with a height of 0.8 meters is used and is placed on the ground plane as per ANSI C63.10.
- 2, Support equipment, if needed, was placed as per ANSI C63.10.
- 3, All I/O cables were positioned to simulate typical actual usage as per ANSI C63.10.
- 4, If a EUT received DC power from the USB Port of Notebook PC, the PC's adapter received AC120V/60Hz power through a Line Impedance Stabilization Network (LISN) which supplied power source and was grounded to the ground plane.
- 5, All support equipments received AC power from a second LISN, if any.
- 6, The EUT test program was started. Emissions were measured on each current carrying line of the EUT using a spectrum Analyzer / Receiver connected to the LISN powering the EUT. The LISN has two monitoring points: Line 1 (Hot Side) and Line 2 (Neutral Side). Two scans were taken: one with Line 1 connected to Analyzer / Receiver and Line 2 connected to a 50 ohm load; the second scan had Line 1 connected to a 50 ohm load and Line 2 connected to the Analyzer / Receiver.
- 7, Analyzer / Receiver scanned from 150 KHz to 30MHz for emissions in each of the test modes.

3.4 Test Result

Pass

Remark:

1. All modes were tested at AC 120V and 240V, only the worst result of AC 120V was reported.
2. All modes were tested at Low, Middle, and High channel, only the worst result of 802.11b Low Channel was reported as below:

Temperature:	24°C	Relative Humidity:	48%
Test Date:	2019-11-07	Pressure:	1010hPa
Test Voltage:	AC 120V, 60Hz	Phase:	Line
Test Mode:	TX (1Mbps) CH00 (worst case)		

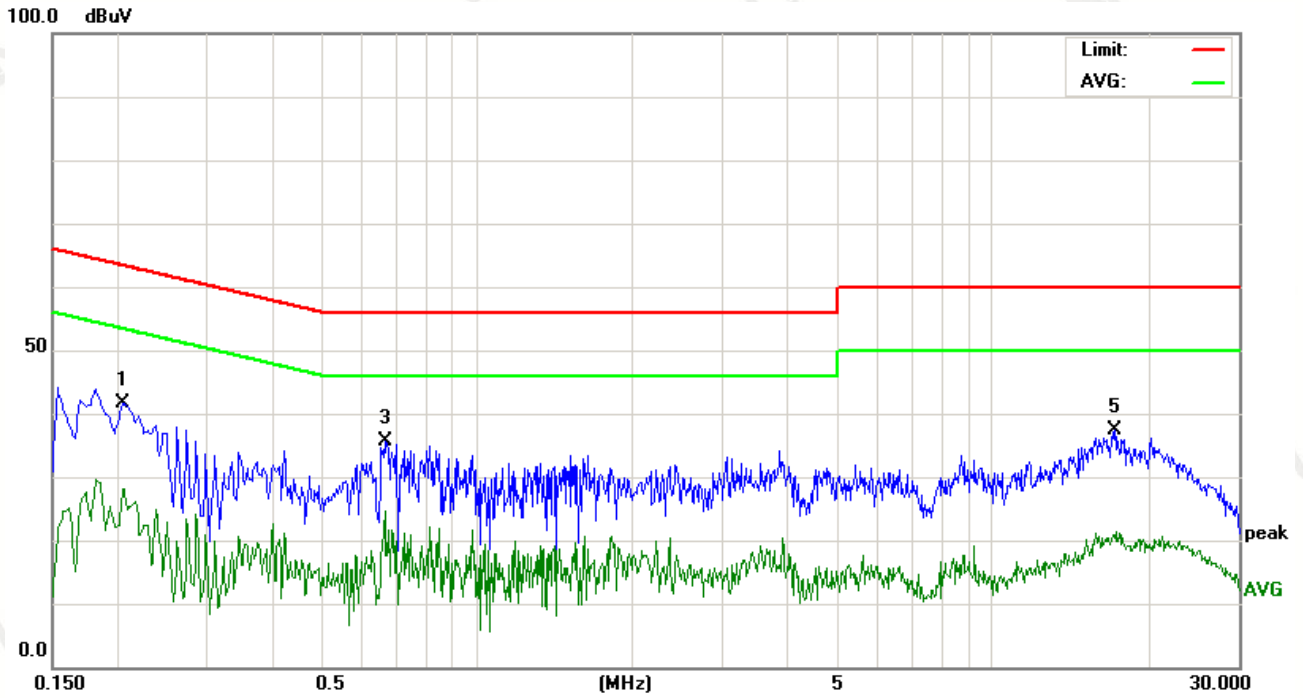

No.	Mk.	Freq. MHz	Reading Level dBuV	Correct Factor dB	Measure- ment dBuV	Limit dBuV	Over dB	Detector
1		0.2059	30.59	11.10	41.69	63.37	-21.68	peak
2		0.2059	17.04	11.10	28.14	53.37	-25.23	AVG
3	*	0.6620	25.64	9.98	35.62	56.00	-20.38	peak
4		0.6620	14.76	9.98	24.74	46.00	-21.26	AVG
5		17.2819	26.60	10.72	37.32	60.00	-22.68	peak
6		17.4539	10.62	10.74	21.36	50.00	-28.64	AVG

Remark: Factor = Insertion Loss + Cable Loss, Result = Reading + Factor, Margin = Result – Limit.

Temperature:	24°C	Relative Humidity:	48%
Test Date:	2019-11-07	Pressure:	1010hPa
Test Voltage:	AC 120V, 60Hz	Phase:	Neutral
Test Mode:	TX (1Mbps) CH00 (worst case)		

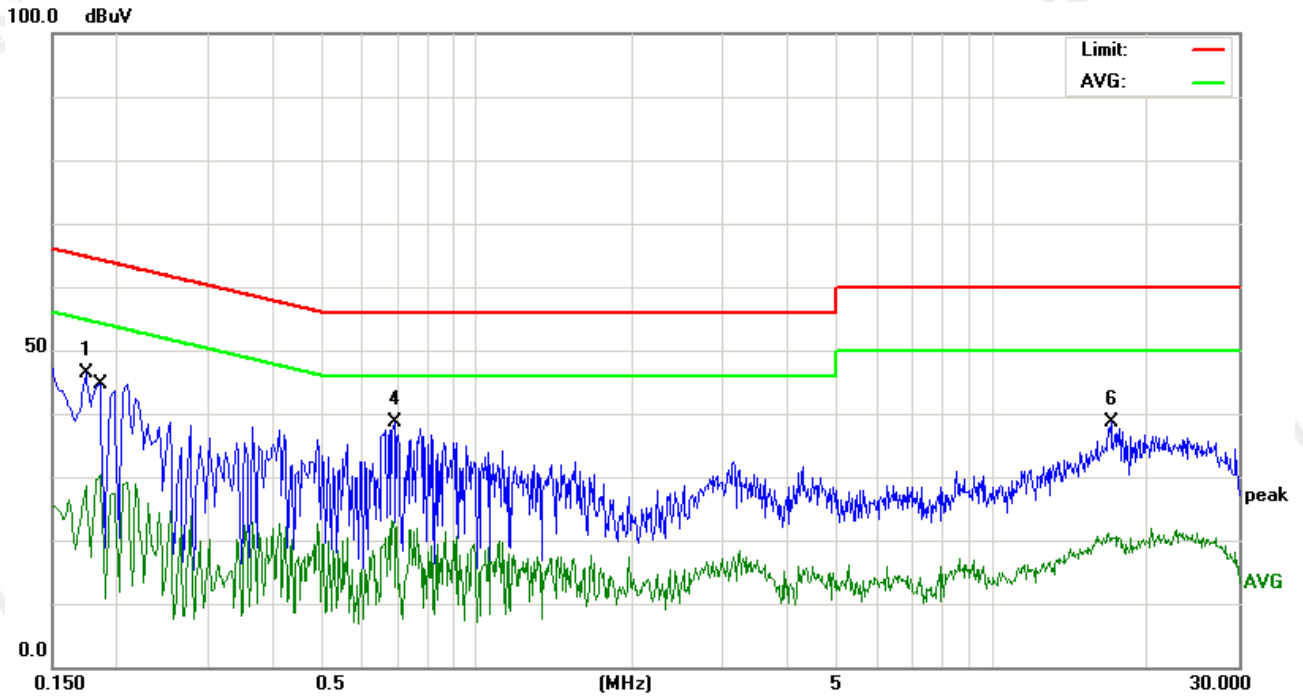

No.	Mk.	Freq. MHz	Reading Level dBuV	Correct Factor dB	Measure- ment dBuV	Limit dBuV	Over dB	Detector
1		0.1740	34.93	11.48	46.41	64.76	-18.35	peak
2		0.1860	18.97	11.31	30.28	54.21	-23.93	AVG
3		0.6860	13.02	9.98	23.00	46.00	-23.00	AVG
4	*	0.6900	28.64	9.98	38.62	56.00	-17.38	peak
5		16.7579	10.36	10.66	21.02	50.00	-28.98	AVG
6		16.9298	28.01	10.68	38.69	60.00	-21.31	peak

Remark: Factor = Insertion Loss + Cable Loss, Result = Reading + Factor, Margin = Result – Limit.

4 RADIATED EMISSION TEST

4.1 Radiation Limit

For unintentional device, according to § 15.109(a), except for Class A digital devices, the field strength of radiated emissions from unintentional radiators at a distance of 3 meters shall not exceed the following values:

Frequency (MHz)	Distance (Meters)	Radiated (dBµV/m)	Radiated (µV/m)
30-88	3	40	100
88-216	3	43.5	150
216-960	3	46	200
Above 960	3	54	500

For intentional device, according to § 15.209(a), the general requirement of field strength of radiated emissions from intentional radiators at a distance of 3 meters shall not exceed the above table.

4.2 Test Setup

1. Radiated Emission Test-Up Frequency Below 30MHz

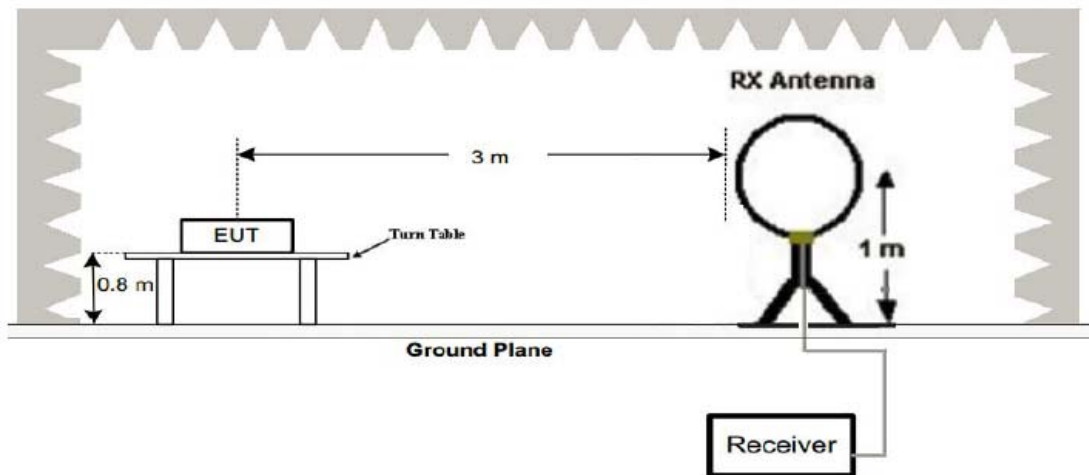

2. Radiated Emission Test-Up Frequency 30MHz~1GHz

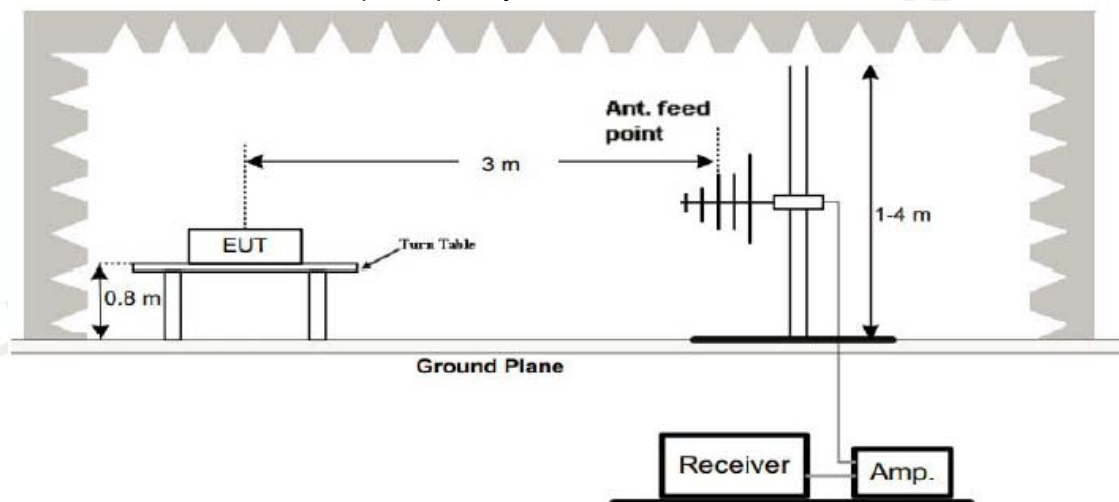

3. Radiated Emission Test-Up Frequency Above 1GHz

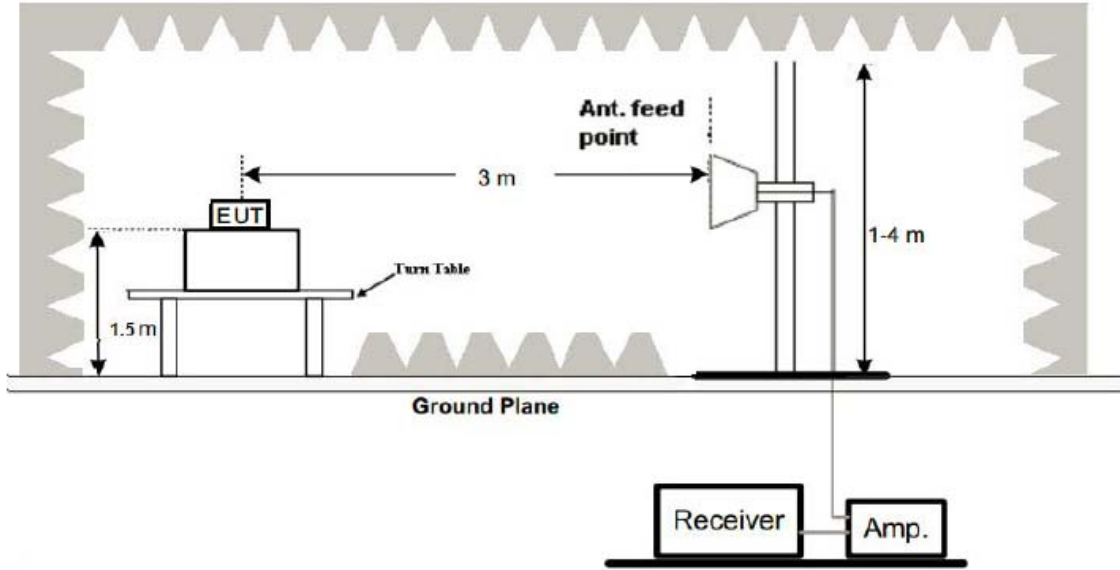

4.3 Test Procedure

1. Below 1GHz measurement the EUT is placed on turntable which is 0.8m above ground plane. And above 1GHz measurement EUT was placed on low permittivity and low tangent turn table which is 1.5m above ground plane.
2. The turntable shall be rotated for 360 degrees to determine the position of maximum emission level.
3. EUT is set 3m away from the receiving antenna, which is varied from 1m to 4m to find out the highest emissions.
4. Maximum procedure was performed on the six highest emissions to ensure EUT compliance.
5. And also, each emission was to be maximized by changing the polarization of receiving antenna both horizontal and vertical.
6. Repeat above procedures until the measurements for all frequencies are complete.
7. The test frequency range from 9KHz to 25GHz per FCC PART 15.33(a).

Note:

For battery operated equipment, the equipment tests shall be performed using a new battery.

4.4 Test Result

PASS

Remark:

1. All modes of mode were tested at Low, Middle, and High channel, and only the worst result of GFSK (1Mbps) Low Channel was reported for below 1GHz test.
2. By preliminary testing and verifying three axis (X, Y and Z) position of EUT transmitted status, it was found that "Z axis" position was the worst, and test data recorded in this report.

Below 30M

Temperature:	22°C	Relative Humidity:	48%
Test Date:	2019-11-07	Pressure:	1010hPa
Test Voltage:	AC 120V, 60Hz	Polarization:	Horizontal
Test Mode:	TX (1Mbps) CH00 (worst case)		

Freq.	Reading	Limit	Margin	State
(MHz)	(dBuV/m)	(dBuV/m)	(dB)	P/F
--	--	--	--	P
--	--	--	--	P

Note:

The amplitude of spurious emissions which are attenuated by more than 20dB below the permissible value has no need to be reported.

Distance extrapolation factor = 20 log (specific distance/test distance)(dB);

Limit line = specific limits(dBuv) + distance extrapolation factor

Below 1GHz Test Results:

Temperature:	22°C	Relative Humidity:	48%
Test Date:	2019-11-07	Pressure:	1010hPa
Test Voltage:	AC 120V, 60Hz	Polarization:	Horizontal
Test Mode:	TX (1Mbps) CH00 (worst case)		

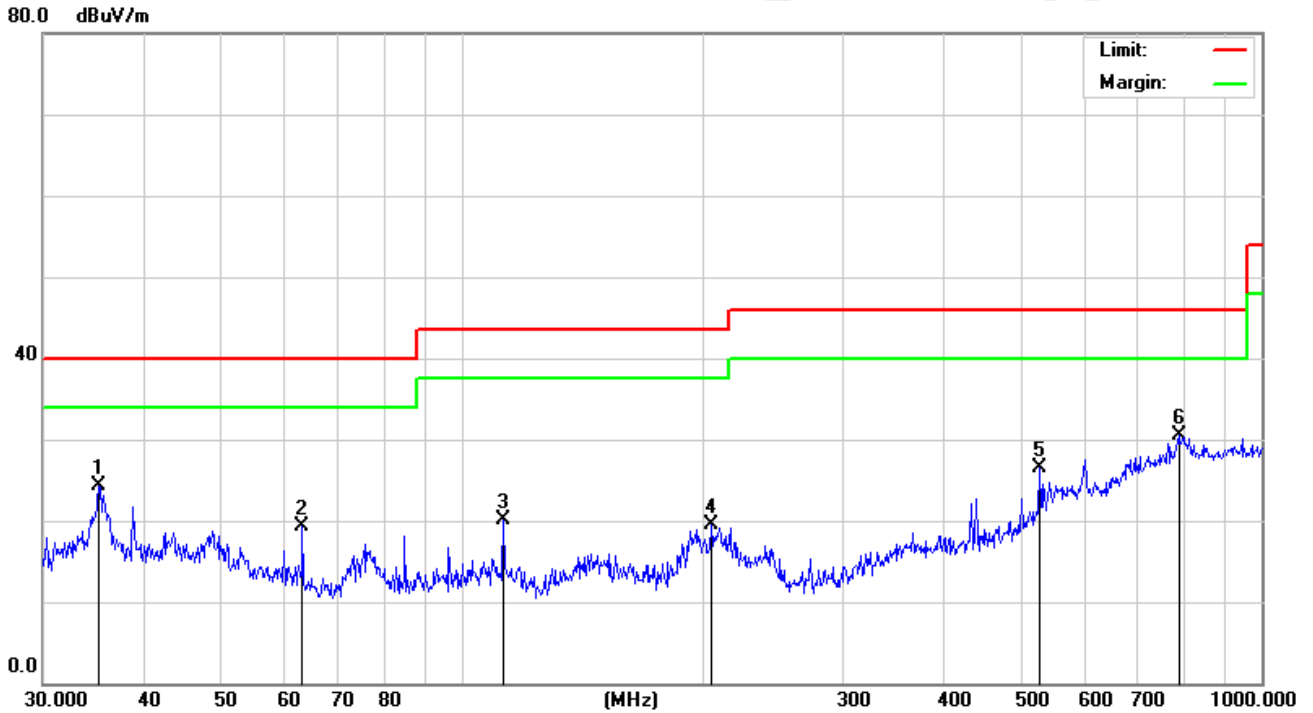

No.	Mk.	Freq. MHz	Reading Level dBuV	Correct Factor dB	Measure- ment dBuV/m	Limit dBuV/m	Over dB	Detector
1		35.2511	29.16	-4.77	24.39	40.00	-15.61	peak
2		63.3132	27.72	-8.35	19.37	40.00	-20.63	peak
3		112.9196	28.18	-8.06	20.12	43.50	-23.38	peak
4		205.6750	24.58	-5.17	19.41	43.50	-24.09	peak
5		528.2458	26.22	0.32	26.54	46.00	-19.46	peak
6	*	787.8513	23.18	7.41	30.59	46.00	-15.41	peak

Remark: Absolute Level = Reading Level + Factor, Margin = Absolute Level – Limit
 Factor = Ant. Factor + Cable Loss – Pre-amplifier

Temperature:	22°C	Relative Humidity:	48%
Test Date:	2019-11-07	Pressure:	1010hPa
Test Voltage:	AC 120V, 60Hz	Polarization:	Vertical
Test Mode:	TX (1Mbps) CH00 (worst case)		

80.0 dBuV/m

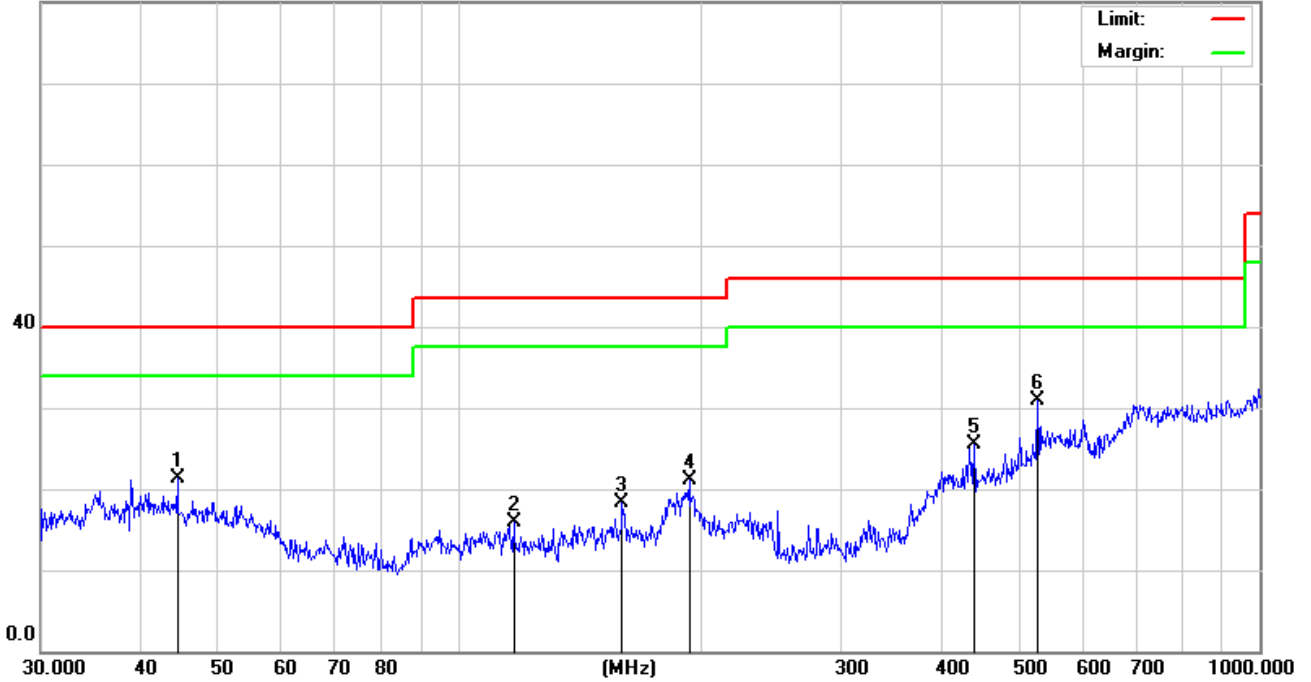

No.	Mk.	Freq. MHz	Reading Level dBuV	Correct Factor dB	Measure- ment dBuV/m	Limit dBuV/m	Over dB	Detector
1		44.4307	23.57	-2.20	21.37	40.00	-18.63	peak
2		116.9495	23.41	-7.52	15.89	43.50	-27.61	peak
3		159.7844	24.86	-6.54	18.32	43.50	-25.18	peak
4		193.7727	28.57	-7.56	21.01	43.50	-22.49	peak
5		440.1963	26.16	-0.68	25.48	46.00	-20.52	peak
6	*	528.2458	26.98	3.83	30.81	46.00	-15.19	peak

Remark: Absolute Level = Reading Level + Factor, Margin = Absolute Level – Limit
Factor = Ant. Factor + Cable Loss – Pre-amplifier

Remark:

- (1) Measuring frequencies from 9 KHz to the 1 GHz, Radiated emission test from 9KHz to 30MHz was verified, and no any emission was found except system noise floor.
- (2) * denotes emission frequency which appearing within the Restricted Bands specified in provision of 15.205, then the general radiated emission limits in 15.209 apply.
- (3) The IF bandwidth of EMI Test Receiver between 30MHz to 1GHz was 120KHz, 1 MHz for measuring above 1 GHz, below 30MHz was 10KHz.

Above 1 GHz Test Results:

CH Low of 2402MHz

Horizontal:

Frequency	Reading Result	Factor	Emission Level	Limits	Margin	Detector
(MHz)	(dBμV)	(dB)	(dBμV/m)	(dBμV/m)	(dB)	Type
4804	43.89	5.06	48.95	74	-25.05	PK
4804	32.18	5.06	37.24	54	-16.76	AV

Remark: Factor = Antenna Factor + Cable Loss – Pre-amplifier. Margin = Absolute Level – Limit

Vertical:

Frequency	Reading Result	Factor	Emission Level	Limits	Margin	Detector
(MHz)	(dBμV)	(dB)	(dBμV/m)	(dBμV/m)	(dB)	Type
4804	42.50	5.06	47.56	74	-26.44	PK
4804	32.43	5.06	37.49	54	-16.51	AV

Remark: Factor = Antenna Factor + Cable Loss – Pre-amplifier. Margin = Absolute Level – Limit

CH Middle of 2440MHz

Horizontal:

Frequency	Reading Result	Factor	Emission Level	Limits	Margin	Detector
(MHz)	(dBμV)	(dB)	(dBμV/m)	(dBμV/m)	(dB)	Type
4880	43.52	5.14	48.66	74	-25.34	PK
4880	32.28	5.14	37.42	54	-16.58	AV

Remark: Factor = Antenna Factor + Cable Loss – Pre-amplifier. Margin = Absolute Level – Limit

Vertical:

Frequency	Reading Result	Factor	Emission Level	Limits	Margin	Detector
(MHz)	(dBμV)	(dB)	(dBμV/m)	(dBμV/m)	(dB)	Type
4880	44.82	5.14	49.96	74	-24.04	PK
4880	32.27	5.14	37.41	54	-16.59	AV

Remark: Factor = Antenna Factor + Cable Loss – Pre-amplifier. Margin = Absolute Level – Limit

CH High of 2480MHz

Horizontal:

Frequency	Reading Result	Factor	Emission Level	Limits	Margin	Detector
(MHz)	(dB μ V)	(dB)	(dB μ V/m)	(dB μ V/m)	(dB)	Type
4960	43.12	5.22	48.34	74	-25.66	PK
4960	32.51	5.22	37.73	54	-16.27	AV

Remark: Factor = Antenna Factor + Cable Loss – Pre-amplifier. Margin = Absolute Level – Limit

Vertical:

Frequency	Reading Result	Factor	Emission Level	Limits	Margin	Detector
(MHz)	(dB μ V)	(dB)	(dB μ V/m)	(dB μ V/m)	(dB)	Type
4960	42.82	5.22	48.04	74	-25.96	PK
4960	32.49	5.22	37.71	74	-36.29	AV

Remark: Factor = Antenna Factor + Cable Loss – Pre-amplifier. Margin = Absolute Level – Limit

Remark :

- (1) Measuring frequencies from 1 GHz to the 25 GHz.
- (2) "F" denotes fundamental frequency; "H" denotes spurious frequency. "E" denotes band edge frequency.
- (3) * denotes emission frequency which appearing within the Restricted Bands specified in provision of 15.205, then the general radiated emission limits in 15.209 apply.
- (4) Data of measurement within this frequency range shown "---" in the table above means the reading of emissions are attenuated more than 20dB below the permissible limits or the field strength is too small to be measured.
- (5) The IF bandwidth of EMI Test Receiver between 30MHz to 1GHz was 120KHz, 1 MHz for measuring above 1 GHz, below 30MHz was 10KHz. The resolution bandwidth of test receiver/spectrum analyzer is 1MHz and video bandwidth is 3MHz for peak measurement with peak detector at frequency above 1GHz. The resolution bandwidth of test receiver/spectrum analyzer is 1MHz and video bandwidth is 10Hz for Average measurement with peak detection at frequency above 1GHz.
- (6) When the test results of Peak Detected below the limits of Average Detected, the Average Detected is not need completed. For example: Top Channel at Fundamental 73.16dBuV/m(PK Value) <93.98(AV Limit), at harmonic 53.20 dBuV/m(PK Value) <54 dBuV/m(AV Limit), the Average Detected not need to completed.

5 BAND EDGE

5.1 Limits

FCC PART 15.247 Emissions radiated outside of the specified frequency bands, except for harmonics, shall be attenuated by at least 20 dB below the level of the fundamental or to the general radiated emission limits in §15.209, whichever is the lesser attenuation.

5.2 Test Procedure

The band edge compliance of RF radiated emission should be measured by following the guidance in ANSI C63.10 with respect to maximizing the emission by rotating the EUT, measuring the emission while the EUT is situated in three orthogonal planes (if appropriate), adjusting the measurement antenna height and polarization etc. Set RBW to 100KHz and VBM to 300KHz to measure the peak field strength and set RBW to 1MHz and VBW to 10Hz to measure the average radiated field strength. The conducted RF band edge was measured by using a spectrum analyzer. Set span wide enough to capture the highest in-band emission and the emission at the band edge. Set RBW to 100 KHz and VBW to 300 KHz, to measure the conducted peak band edge.

5.3 Test Result

PASS

Operation Mode: TX 1Mbps Mode

Vertical

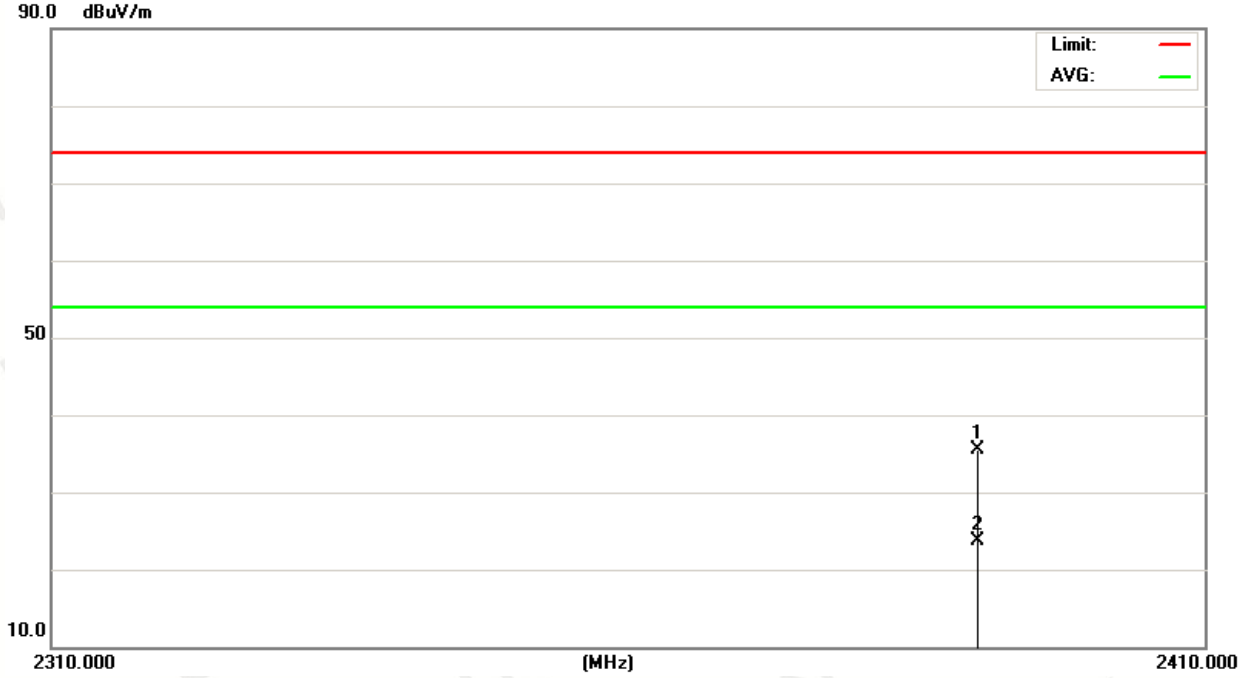

No.	Mk.	Freq. MHz	Reading Level dBuV	Correct Factor dB	Measure- ment dBuV/m	Limit dBuV/m	Over dB	Detector
1		2390.000	41.25	-5.79	35.46	74.00	-38.54	peak
2	*	2390.000	29.46	-5.79	23.67	54.00	-30.33	AVG

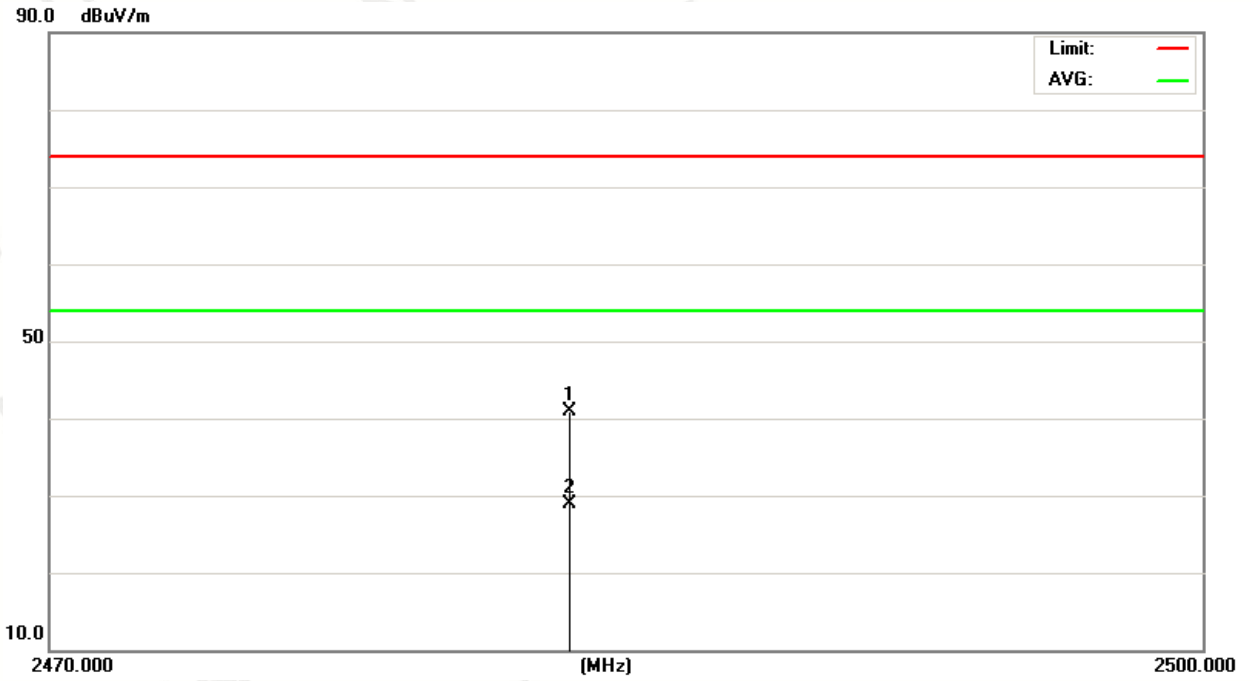

No.	Mk.	Freq.	Reading Level	Correct Factor	Measurement	Limit	Over	Detector
		MHz	dBuV	dB	dBuV/m	dBuV/m	dB	
1		2483.500	45.85	-4.98	40.87	74.00	-33.13	peak
2	*	2483.500	33.93	-4.98	28.95	54.00	-25.05	AVG

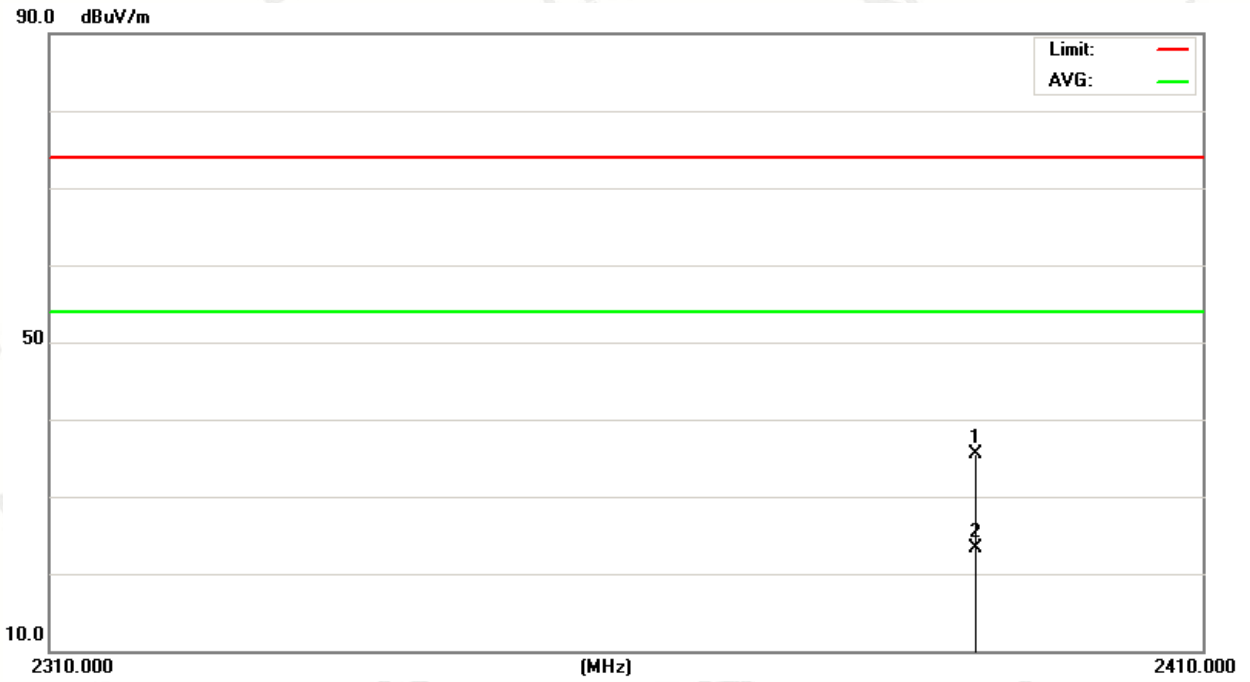

No.	Mk.	Freq. MHz	Reading Level dBuV	Correct Factor dB	Measure- ment dBuV/m	Limit dBuV/m	Over dB	Detector
1		2390.000	41.32	-5.79	35.53	74.00	-38.47	peak
2	*	2390.000	29.13	-5.79	23.34	54.00	-30.66	AVG

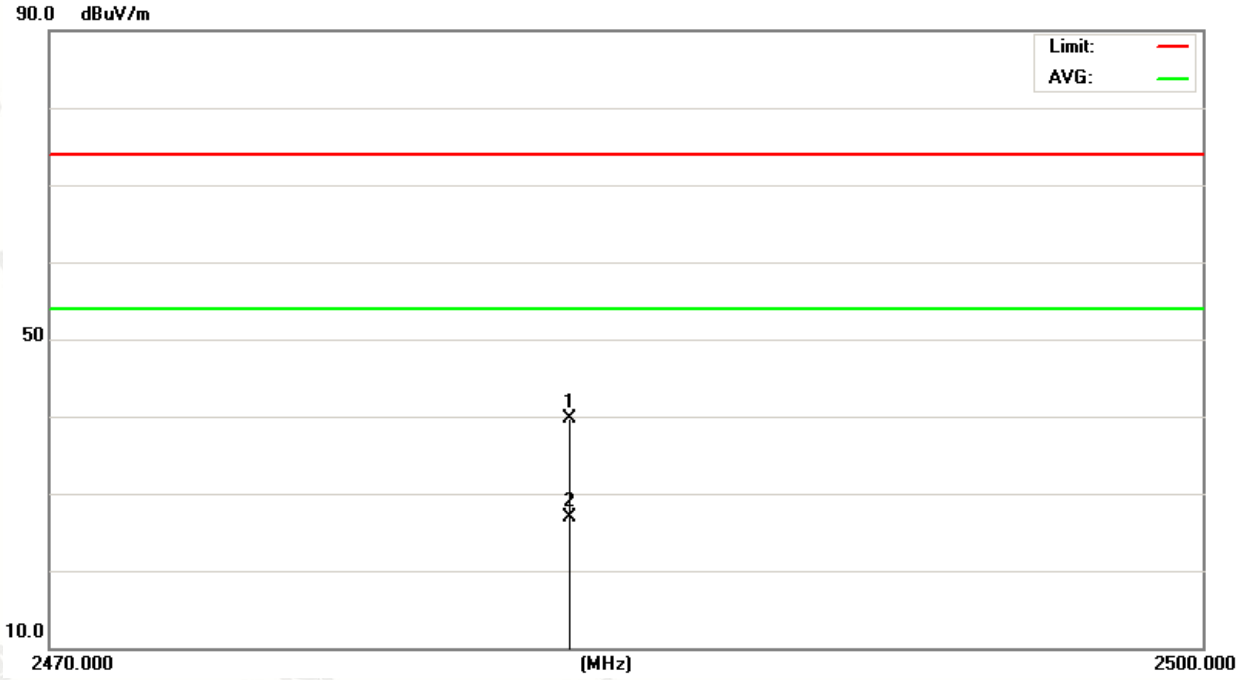

No.	Mk.	Freq. MHz	Reading Level dBuV	Correct Factor dB	Measure- ment dBuV/m	Limit dBuV/m	Over dB	Detector
1		2483.500	44.76	-4.98	39.78	74.00	-34.22	peak
2	*	2483.500	31.88	-4.98	26.90	54.00	-27.10	AVG

6 OCCUPIED BANDWIDTH MEASUREMENT

6.1 Test Limit

FCC Part15(15.247), Subpart C				
Section	Test Item	Limit	Frequency Range (MHz)	Result
15.247(a)(2)	Bandwidth	$\geq 500\text{KHz}$ (6dB bandwidth)	2400-2483.5	PASS

6.2 Test Procedure

1. The EUT was placed on a turn table which is 0.8m above ground plane.
2. Set EUT as normal operation.
3. Based on FCC Part15 C Section 15.247: RBW=100KHz, VBW=300KHz.
4. The useful radiated emission from the EUT was detected by the spectrum analyzer with peak detector.

6.3 Measurement Equipment Used

Same as Radiated Emission Measurement

6.4 Test Result

PASS

EUT Set Mode	CH or Frequency	6 dB bandwidth	99% dB bandwidth	Limt	Conclusion
		Result (MHz)	Result (MHz)		
BLE	CH 00	0.515	0.916	>500KHz	PASS
	CH 19	0.513	0.919	>500KHz	PASS
	CH 39	0.513	0.920	>500KHz	PASS

CH: 2402MHz

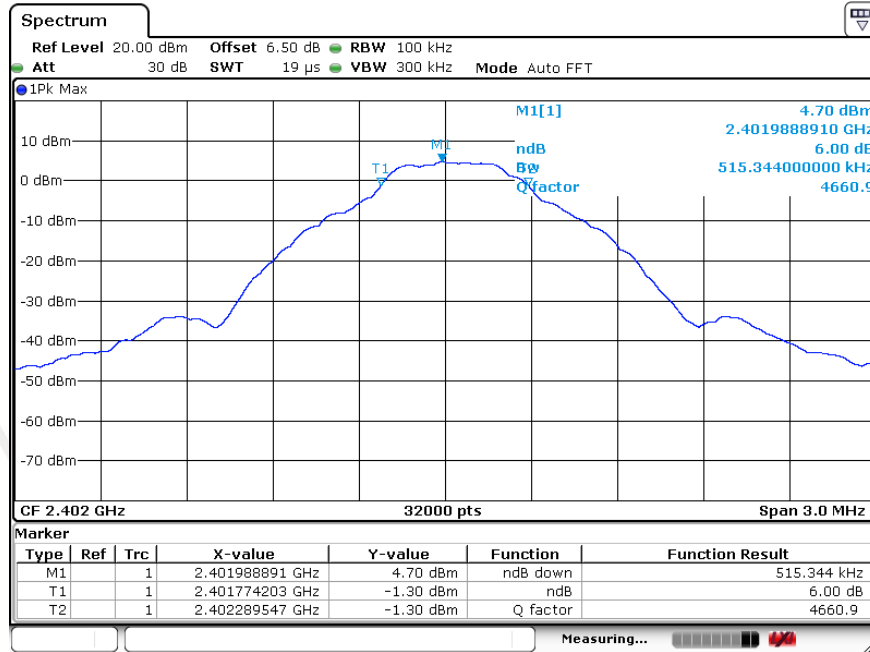

CH: 2440MHz

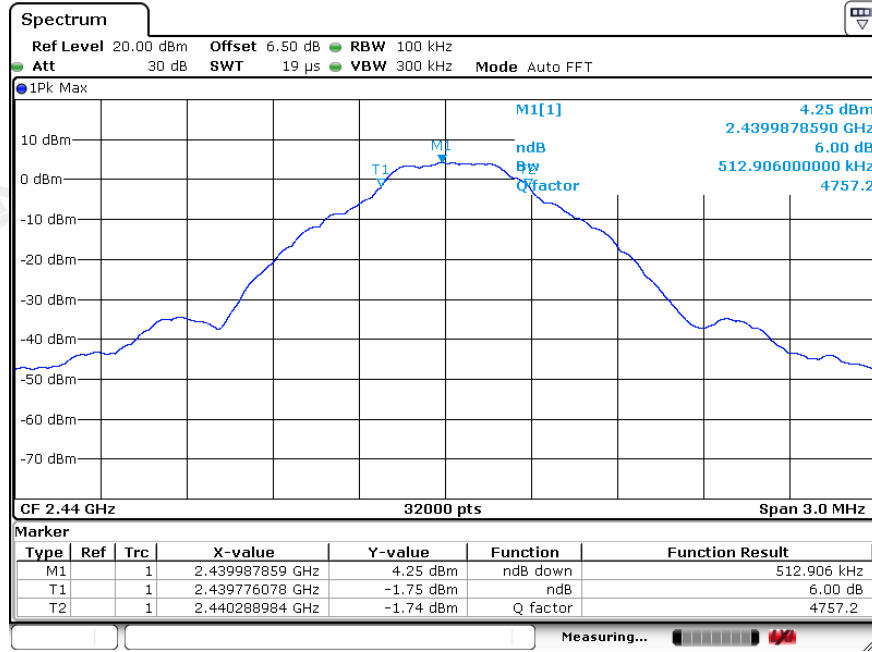

CH: 2480MHz

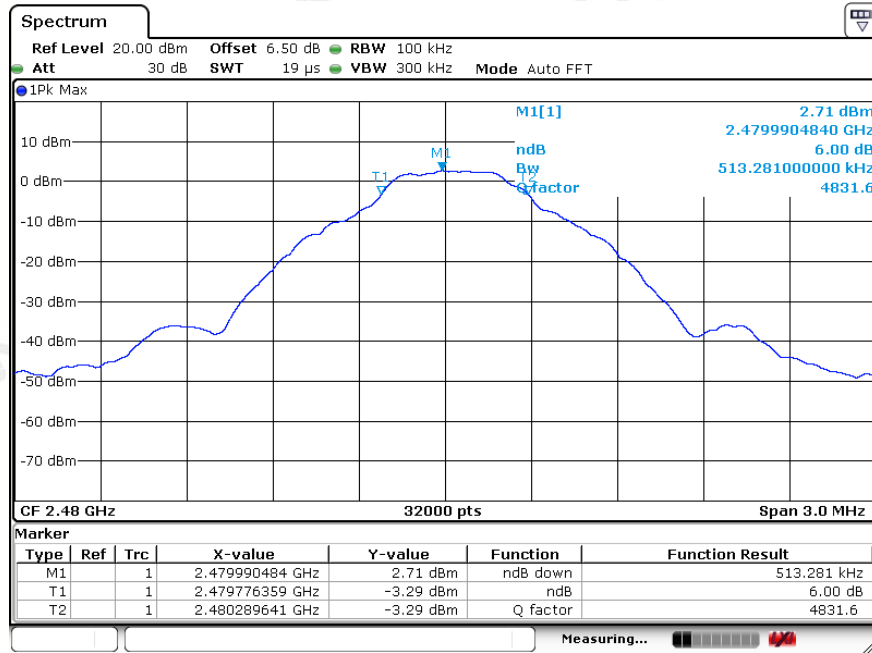

CH: 2402MHz

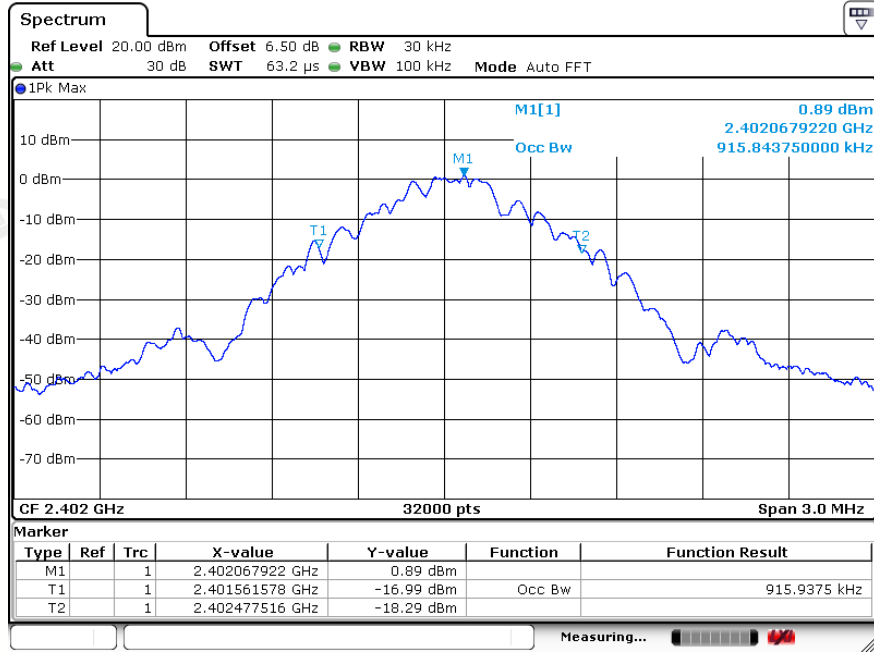

CH: 2440MHz

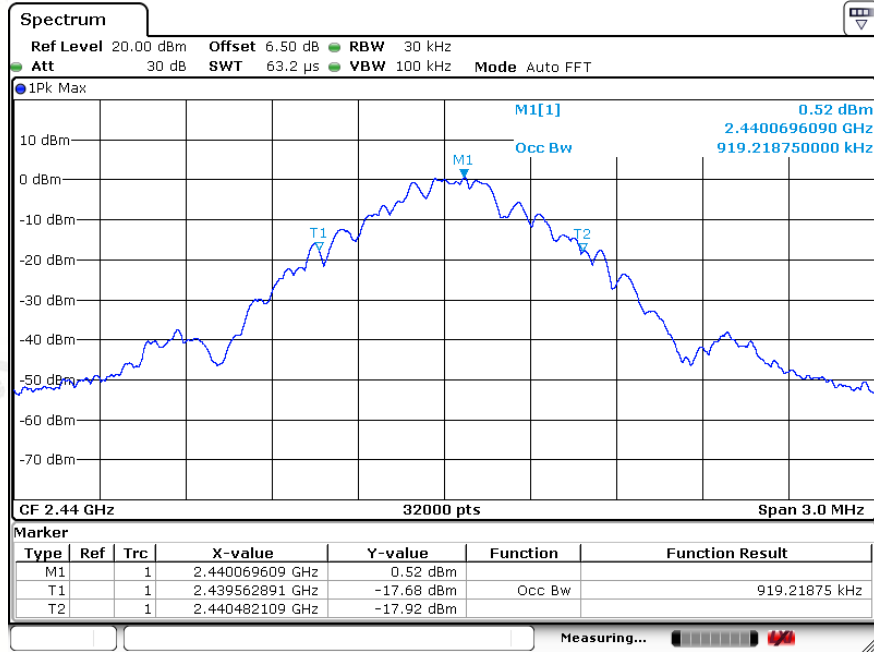



CH: 2480MHz

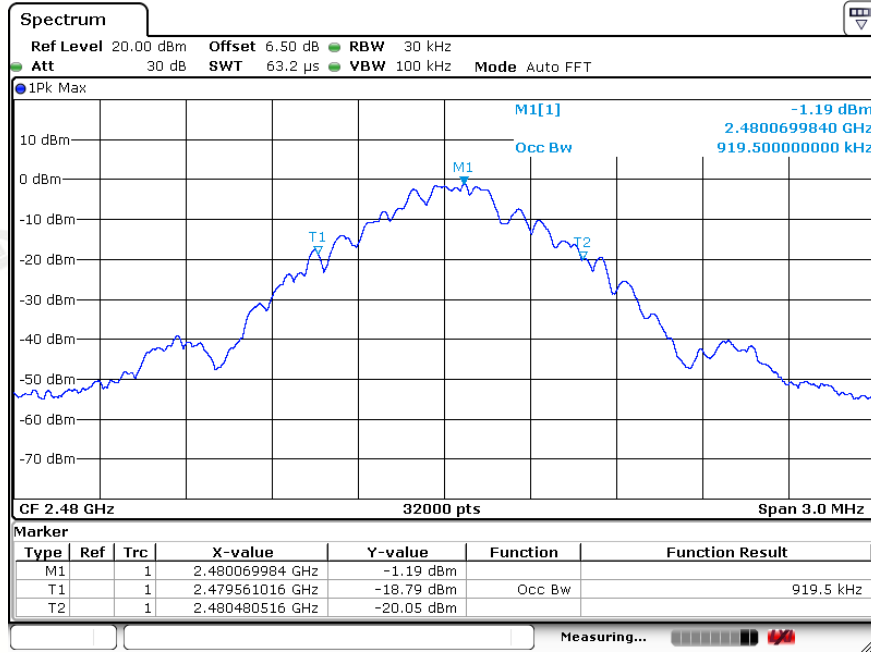

7 POWER SPECTRAL DENSITY TEST

7.1 Test Limit

FCC Part15(15.247), Subpart C				
Section	Test Item	Limit	Frequency Range (MHz)	Result
15.247	Power Spectral Density	8 dBm (in any 3KHz)	2400-2483.5	PASS

7.2 Test Procedure

1. The EUT was placed on a turn table which is 0.8m above ground plane.
2. Set EUT as normal operation.
3. Based on FCC Part15 C Section 15.247: RBW=3KHz, VBW=10KHz.
4. The useful radiated emission from the EUT was detected by the spectrum analyzer with peak detector.

7.3 Measurement Equipment Used

Same as Radiated Emission Measurement

7.4 Test Result

PASS

TX 1Mbps Mode			
Frequency (MHz)	Power Density (dBm/3KHz)	Limit (dBm/3KHz)	Result
2402	-4.90	8	PASS
2440	-5.17	8	PASS
2480	-7.08	8	PASS

CH: 2402MHz

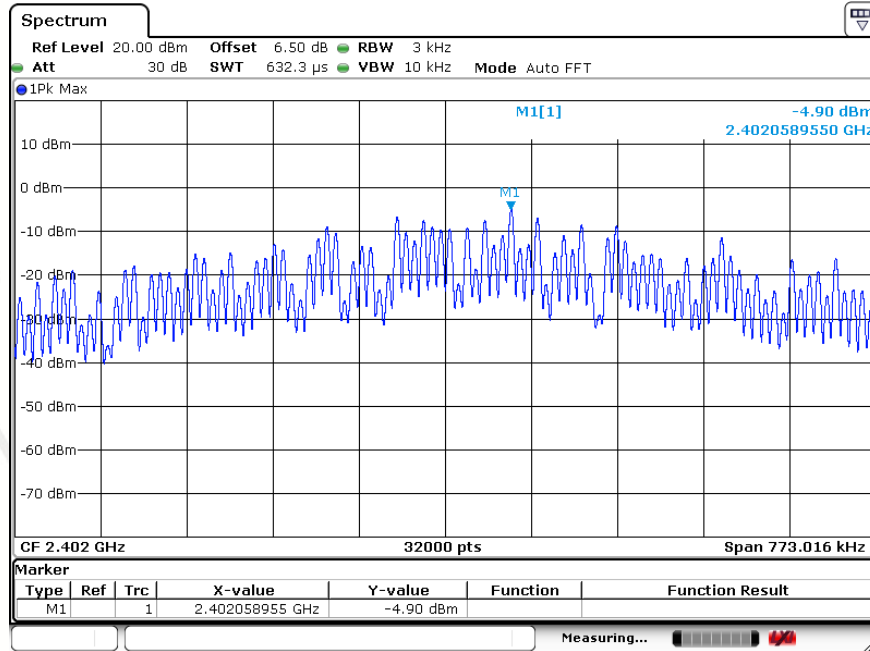

CH: 2440MHz

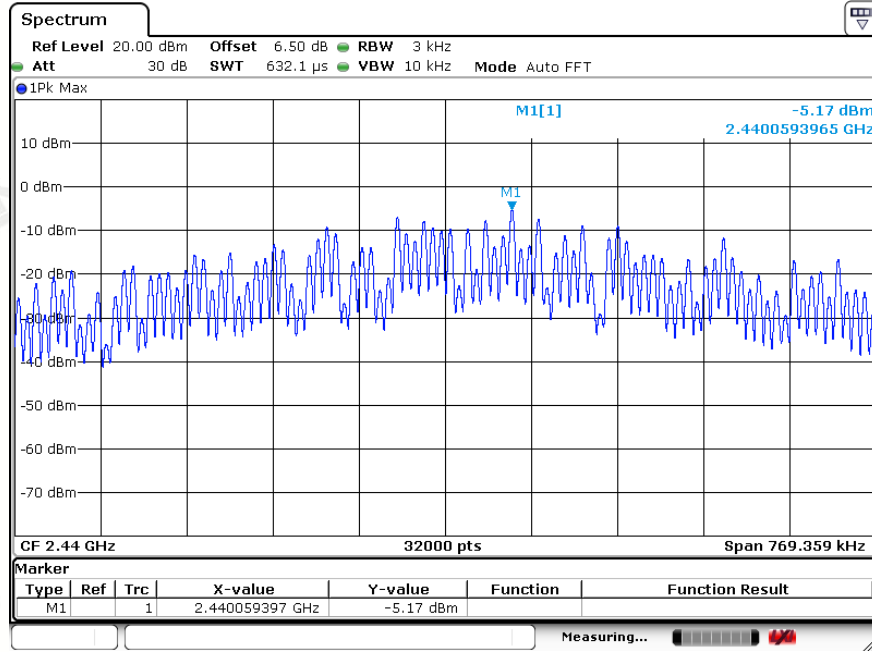

CH: 2480MHz

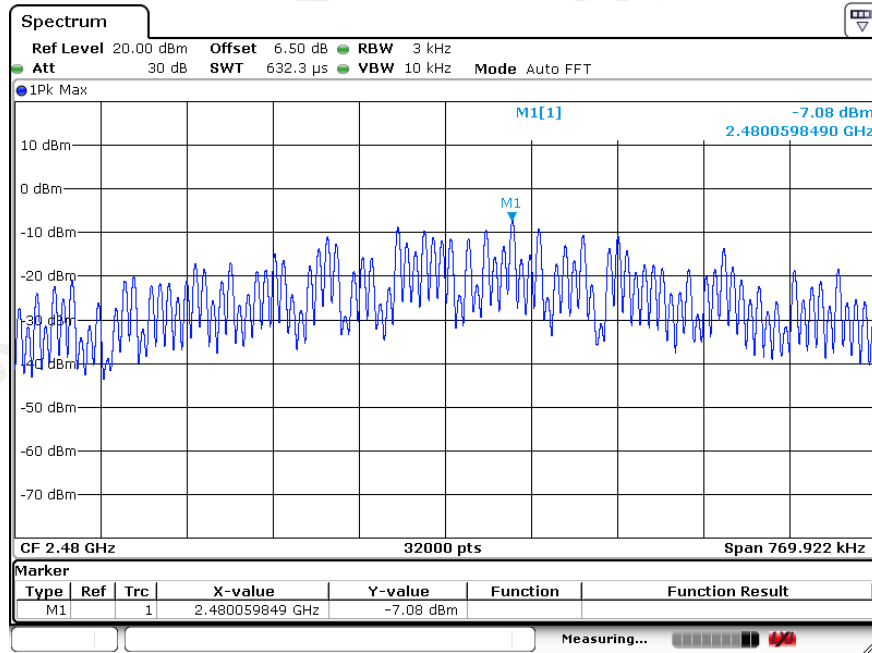

8 PEAK OUTPUT POWER TEST

8.1 Test Limit

FCC Part15(15.247), Subpart C				
Section	Test Item	Limit	Frequency Range (MHz)	Result
15.247(b)(3)	Peak Output Power	1 watt or 30dBm	2400-2483.5	PASS

8.2 Test Procedure

1. The EUT was placed on a turn table which is 0.8m above ground plane.
2. The EUT was directly connected to the Power meter.

8.3 Measurement Equipment Used

Same as Radiated Emission Measurement

8.4 Test Result

PASS

All the test modes completed for test.

TX 1Mbps Mode			
Test Channel	Frequency (MHz)	Maximum Peak Conducted Output Power (dBm)	LIMIT (dBm)
CH01	2402	5.61	30
CH06	2440	5.23	30
CH11	2480	3.36	30

9 OUT OF BAND EMISSIONS TEST

9.1 Test Limit

In any 100 kHz bandwidth outside the frequency band in which the spread spectrum or digitally modulated intentional radiator is operating, the radio frequency power that is produced by the intentional radiator shall be at least 20 dB below that in the 100 kHz bandwidth within the band that contains the highest level of the desired power, based on either an RF conducted or a radiated measurement, provided the transmitter demonstrates compliance with the peak conducted power limits. If the transmitter complies with the conducted power limits based on the use of RMS averaging over a time interval, as permitted under paragraph (b)(3) of this section, the attenuation required under this paragraph shall be 30 dB instead of 20 dB.

9.2 Test Procedure

1. The EUT was placed on a turn table which is 0.8m above ground plane.
2. Set EUT as TX operation and connect directly to the spectrum analyzer.
3. Based on FCC Part15 C Section 15.247: RBW=100KHz, VBW=300KHz.
4. Set detected by the spectrum analyzer with peak detector.

9.3 Test Setup

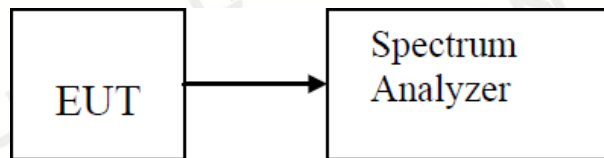

9.4 Test Result

PASS

CH: 2402MHz

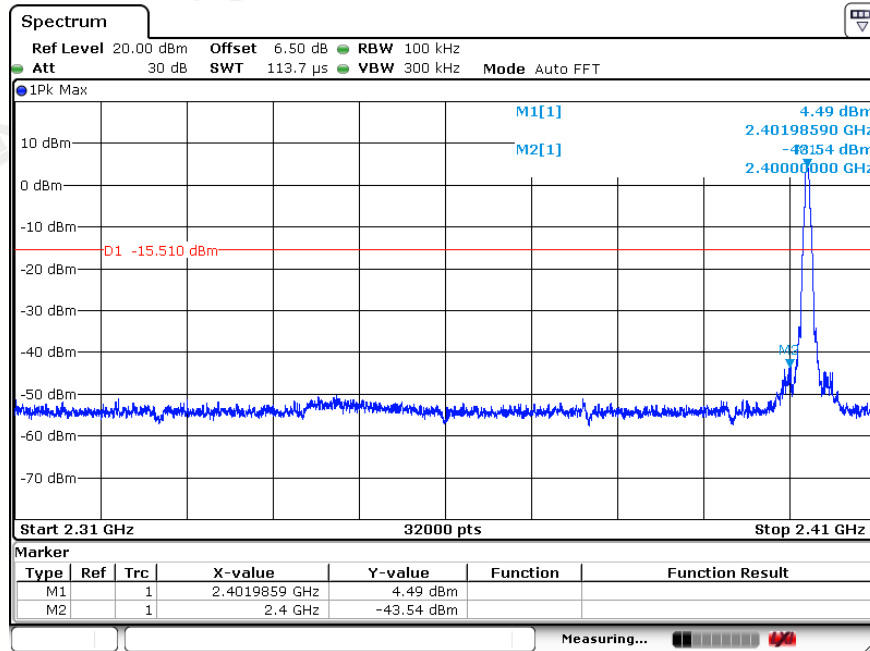

CH: 2480MHz

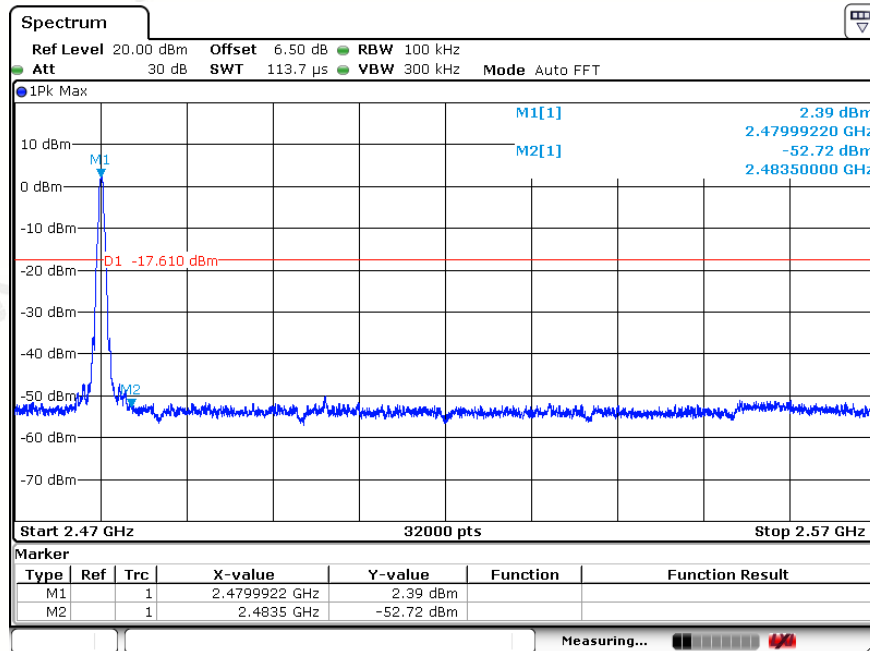

10 ANTENNA REQUIREMENT

Standard Applicable:

For intentional device, according to FCC 47 CFR Section 15.203, an intentional radiator shall be designed to ensure that no antenna other than that furnished by the responsible party shall be used with the device.

Antenna Connected Construction

The antenna used in this product is a PCB Antenna, The directional gains of antenna used for transmitting is 0dBi.

ANTENNA:

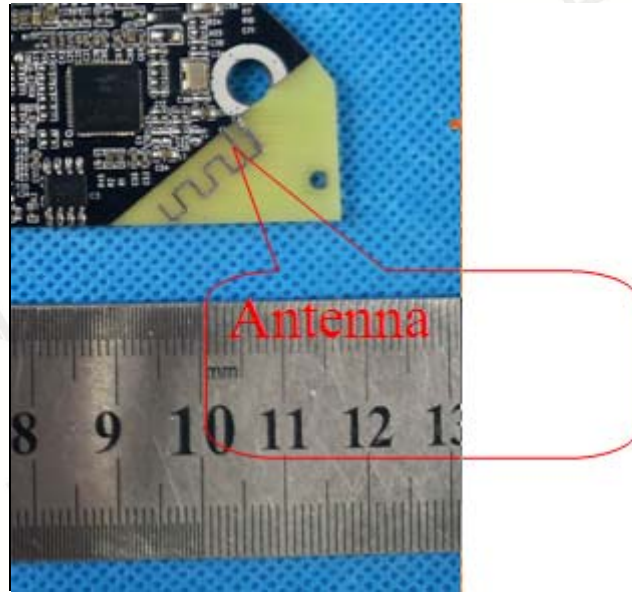

End of Report