

PHILIPS

Soundbar

7000 Series

TAB7568



User manual

Register your product and get support at:
www.philips.com/support

Contents

1	Important safety instructions	3	5	Product specifications	19
	Safety	3			
	Care for your product	4			
	Care of the environment	4			
	Declaration of conformity	4			
	Help and support	4			
	FCC and IC information	5			
<hr/>					
2	Your soundbar	6	6	Troubleshooting	20
	What's in the box	6			
	Main unit	6			
	Connectors	7			
	Wireless subwoofer	7			
	Surround speaker	7			
	Remote control	8			
	Prepare the remote control	8			
	Placement	9			
	Wall mount	10			
<hr/>					
3	Connect	11	7	Trademarks	22
	Dolby Audio	11			
	Connect to HDMI ARC socket	11			
	Connect to Optical socket	12			
	Connect to AUX socket	12			
	Connect to power	12			
	Pair up with the subwoofer	13			
	Connect surround speakers to the subwoofer	13			
<hr/>					
4	Use your soundbar	14			
	Turn ON and OFF	14			
	Select source	14			
	Select equalizer (EQ) effect	14			
	Adjust the volume	14			
	Settings menu	15			
	Factory reset	17			
	Bluetooth operation	17			
	USB operation	18			
	AUX / OPTICAL / HDMI	18			
	ARC operation				

1 Important safety instructions

Read and understand all instructions before you use your product. If damage is caused by failure to follow instructions, the warranty does not apply.

Safety

Risk of electric shock or fire!

- Before you make or change any connections, make sure that all devices are disconnected from the power outlet.
- Never expose the product and accessories to rain or water. Never place liquid containers, such as vases, near the product. If liquids are spilt on or into the product, disconnect it from the power outlet immediately. Contact Consumer Care to have the product checked before use.
- Never place the product and accessories near naked flames or other heat sources, including direct sunlight.
- Never insert objects into the ventilation slots or other openings on the product.
- Where the mains plug or an appliance coupler is used as the disconnect device, the disconnect device shall remain readily operable.
- Battery (battery pack or batteries installed) shall not be exposed to excessive heat such as sunshine, fire or the like.
- Disconnect the product from the power outlet before lightning storms.
- When you disconnect the power cord, always pull the plug, never the cable.
- Use the product in tropical and/or moderate climates.

Risk of short circuit or fire!

- For identification and supply ratings, see the type plate at the back or bottom of the product.
- Before you connect the product to the power outlet, ensure that the power voltage matches the value printed on the back or bottom of the product. Never connect the product to the power outlet if the voltage is different.

Risk of injury or damage to this product!

- For wall mounting, this product must be securely attached to the wall in accordance with the installation instructions. Use only the supplied wall mount bracket (if available). Improper wall mounting may result in accident, injury or damage. If you have any query, contact Consumer Care in your country.
- Never place the product or any objects on power cords or on other electrical equipment.
- If the product is transported in temperatures below 5°C, unpack the product and wait until its temperature matches room temperature before connecting it to the power outlet.
- Parts of this product can be made of glass. Handle with care to avoid injury and damage.
- Please use the product safely in an environment with temperature between 0°C and 40°C.

Risk of overheating!

- Never install this product in a confined space. Always leave a space of at least four inches around the product for ventilation. Ensure curtains or other objects never cover the ventilation slots on the product.

Risk of contamination!

- Do not mix batteries (old and new or carbon and alkaline , etc.).

- **CAUTION:** Danger of explosion if batteries are incorrectly replaced. Don't disposal of a battery into fire or a hot oven, or mechanically crushing or cutting of a Battery. Don't leaving a battery in an extremely high temperature surrounding environment To avoid battery subjected to extremely low air pressure.



This is CLASS II apparatus with double insulation, and no protective earth provided.



AC voltage



Follow the instructions in the user manual!



WARNING!
Warning: Risk of electric shock!



The exclamation mark is intended to alert the user to the presence of important operating instructions.



The symbol indicates DC voltage

Note

- The rating label is pasted on the bottom or back of the equipment.

Care for your product

Use only microfiber cloth to clean the product.

Care of the environment

Disposal of your old product and battery



Your product is designed and manufactured with high quality materials and components, which can be recycled and reused.



This symbol on a product means that the product is covered by European Directive 2012/19/EU.



This symbol means that the product contains batteries covered by European Directive 2013/56/EU which cannot be disposed of with normal household waste.

Inform yourself about the local separate collection system for electrical and electronic products and batteries. Follow local rules and never dispose of the product and batteries with normal household waste. Correct disposal of old products and batteries helps prevent negative consequences for the environment and human health.

Removing the disposable batteries

To remove the disposable batteries, see battery installation section.

Declaration of conformity

This product complies with the radio interference requirements of the European community.

Hereby, TP Vision Europe B.V. declares that the product is in compliance with the essential requirements and other relevant provisions of RED Directive 2014/53/EU and UK Radio Equipment Regulations SI 2017 No 1206. You can find the Declaration of Conformity on www.philips.com/support.

Help and support

For extensive online support, visit www.philips.com/support to:

- download the user manual and the quick start guide
- watch video tutorials (available only for selected models)

- find answers to frequently answered questions (FAQs)
- email us a question
- chat with our support representative.

Follow the instructions on the website to select your language, and then enter your product model number.

Alternatively, you can contact Consumer Care in your country. Before you contact, note down the model number and serial number of your product. You can find this information on the back or bottom of your product.

FCC information

NOTE: This equipment has been tested and found to comply with the limits for a Class B digital device, pursuant to Part 15 of the FCC Rules. These limits are designed to provide reasonable protection against harmful interference in a residential installation. This equipment generates, uses and can radiate radio frequency energy and, if not installed and used in accordance with the instructions, may cause harmful interference to radio communications.

However, there is no guarantee that interference will not occur in a particular installation. If this equipment does cause harmful interference to radio or television reception, which can be determined by turning the equipment off and on, the user is encouraged to try to correct the interference by one or more of the following measures:

- Reorient or relocate the receiving antenna.
- Increase the separation between the equipment and receiver.
- Connect the equipment into an outlet on a circuit different from that to which the receiver is connected.
- Consult the dealer or an experienced radio / TV technician for help.

FCC&IC Warning:

- This equipment should be installed and operated with minimum distance 20cm between the radiator & your body.
- Changes or modifications to this unit not expressly approved by the party responsible for compliance could void the user's authority to operate the equipment.

IC-Canada: CAN ICAN ICES-003(B) / NMB-003(B)

This device contains licence-exempt transmitter(s) / receiver(s) that comply with Innovation, Science and Economic Development Canada's licence-exempt RSS(s). Operation is subject to the following two conditions:

1. This device may not cause interference.
2. This device must accept any interference, including interference that may cause undesired operation of the device.

Avis d'Industrie Canada: CAN ICES-003 (B)/NMB-003(B)

L'émetteur/récepteur exempt de licence contenu dans le présent appareil est conforme aux CNR d'Innovation, Sciences et Développement économique Canada applicables aux appareils radio exempts de licence. L'exploitation est autorisée aux deux conditions suivantes :

1. L'appareil ne doit pas produire de brouillage;
2. L'appareil doit accepter tout brouillage radioélectrique subi, même si le brouillage est susceptible d'en compromettre le fonctionnement.

2 Your soundbar

Congratulations on your purchase, and welcome to Philips! To fully benefit from the support that Philips offers, register your soundbar at www.philips.com/support.

What's in the box

Check and identify the items in the package:

- Soundbar x 1
- Wireless subwoofer x 1
- Surround speakers x 2
- Remote control x 1
- Power cord (subwoofer) x 1
- Power cord (soundbar) x 1
- Surround speaker audio cables x 2
- HDMI cable x 1
- Wall mount kit x 1
- Quick start guide x 1
- Warranty card x 1
- Safety sheet x 1

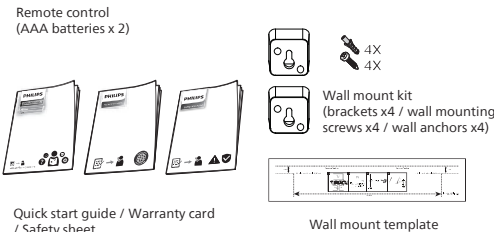
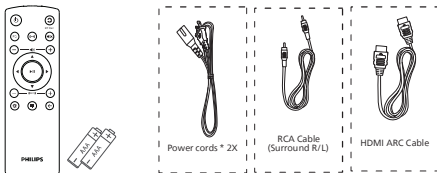
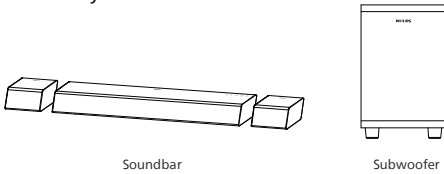

- Power cord quantity and plug type vary by regions.
- Images, illustrations and drawings shown on this User Manual are for reference only, actual product may vary in appearance.

Main unit

This section includes an overview of the main unit.

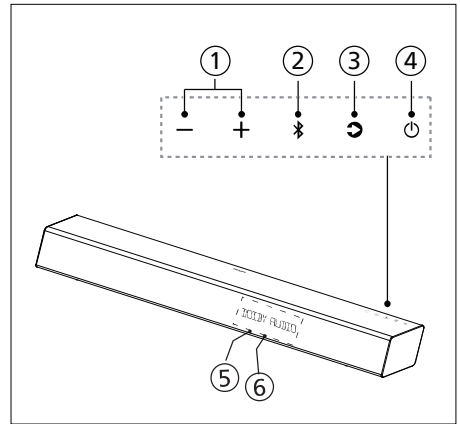

- ➊ **+/- (Volume) button**
Increase or decrease volume.
- ➋ **Bluetooth button**
 - Press to switch to BT source
 - Press and hold to disconnect from all Bluetooth devices and enter pairing mode.
- ➌ **Source button**
Press to select an input source. (The preset source is HDMI ARC by default.)
- ➍ **Standby-On button**
Switch the soundbar on or to standby.
- ➎ **Soundbar's display screen**
- ➏ **Remote control sensor**

Connectors

This section includes an overview of the connectors available on your soundbar.

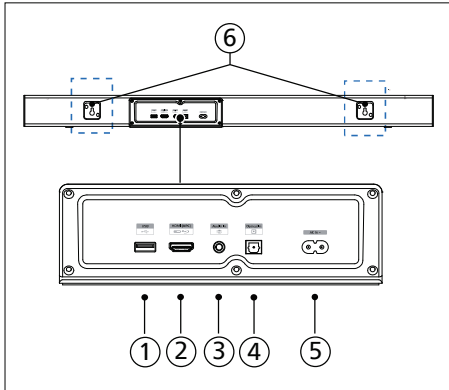

- ① **USB**
 - Connect to a USB storage device for audio media play.
- ② **HDMI out (ARC)**
Connect to the HDMI (ARC) input on the TV.
- ③ **Audio in**
Audio input from, for example, an MP3 player (3.5mm jack).
- ④ **Optical in**
Connect to an optical audio output on the TV or a digital device.
- ⑤ **AC in**
Connect to the power supply.
- ⑥ **Wall mounting bracket slot**

Wireless subwoofer

This section includes an overview of the wireless subwoofer.

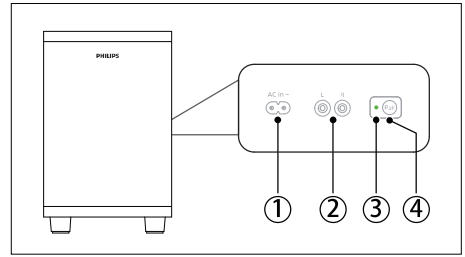

- ① **AC in**
Connect to the power supply.
- ② **Connector to surround speaker**
Connect to surround speaker.
- ③ **Subwoofer indicator**
Determine the status based on the wireless subwoofer indicator.
- ④ **Pair button**
Press and hold to enter the pairing mode for the subwoofer.

LED State	Status
Fast blink	Subwoofer in pairing mode
Constant on	Connected / Pairing successful
Slow blink	Connection / Pairing failed

Surround Speakers

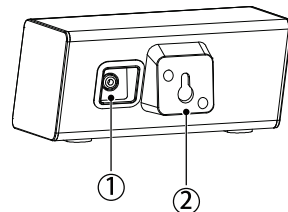

- ① Connector to subwoofer.
- ② Wall mounting bracket.

Remote control

This section includes an overview of the remote control.

- ① **⏻ (Standby-On) button**
Switch the soundbar On or to standby.
- ② **🔍 (Source)**
Select an input source for the soundbar.
- ③ **EQ**
Select from the four EQ modes:
Movie/Music/Voice/Stadium.
- ④ **⦿ (Sound Effect)**
Select from the three sound effects:
VRT X (Virtual X), AUVOL (Auto Volume Leveling), NIGHT (Night mode).
- ⑤ **🔇 (Mute)**
Mute or restore sound output.
- ⑥ **🔊 - (System volume)**
Decrease system volume level.
- ⑦ **🔊 + (System volume)**
Increase system volume level.
- ⑧ **Navigation**
 - ▲ ▼ (Up/Down)
Navigation Up/Down in menu structure.
 - ◀ ▶ (Left/Right)
 - Skip to the previous or next track in USB/BT mode.
 - Navigation Left/Right in menu structure.
 - ▶|| (Play / Pause)
Start, pause or resume play in USB/ BT mode; confirm the selection of the menu.
- ⑨ **⦿ (SUB) - (Subwoofer volume)**
Decrease subwoofer volume level.
- ⑩ **⦿ (SUB) + (Subwoofer volume)**
Increase subwoofer volume level.
- ⑪ **⚙️ (Settings)**
Enter settings menu.

- ⑫ **☰ (Sound mode)**
Select from the three sound modes:
BASS, TREB (treble), AV SYNC (Audio Delay).
- ⑬ **⬅️ (Back)**
Back to previous level.

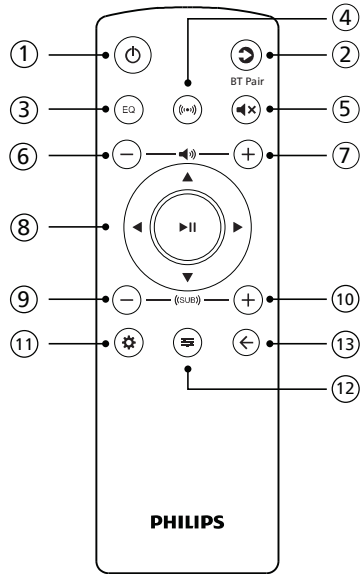

Prepare the remote control

- The provided remote control allows the unit to be operated from a distance.
- Even if the remote control is operated within the effective range 19.7 feet (6m), remote control operation may be impossible if there are any obstacles between the unit and the remote control.
- If the remote control is operated near other products which generate infrared rays, or if other remote control devices using infra-red rays are used near the unit, it may operate incorrectly. Conversely, the other products may operate incorrectly.

Replace the remote control battery

Slide to remove the battery compartment cover, insert 2 AAA batteries (1.5V) with correct polarity, then slide the battery compartment cover back into position.

- Make sure the (+) and (-) ends of the batteries match the (+) and (-) ends indicated in the battery compartment.

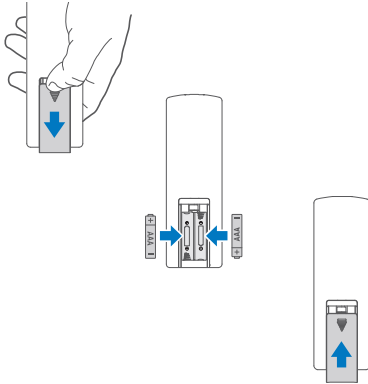

- Do not place the remote control on a wet object.
- Do not place the remote control under direct sunlight or near sources of excessive heat.
- Remove the battery from the remote control when not in use for a long period of time, as corrosion or battery leakage may occur and result in physical injury, and/or property damage, and/or fire.
- Do not use any batteries other than those specified
- Do not mix new batteries with old ones.
- Never recharge a battery unless it is confirmed to be a rechargeable type.

Placement

For best results, place your subwoofer as shown below. Besides, place your satellites at the angle behind the sofa as shown below. Noted, the satellites should be placed 5m away from the subwoofer, as the RCA cable is 5m long

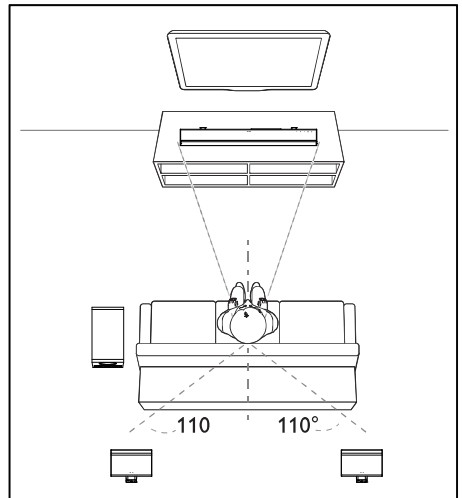

Precautions concerning batteries

- Be sure to insert the batteries with correct positive “ \oplus ” and negative “ \ominus ” polarities.
- Use batteries of the same type. Never use different types of batteries together.
- Either rechargeable or non-rechargeable batteries can be used. Refer to the precautions on their labels.
- Be aware of your fingernails when removing the battery cover and the battery.
- Do not drop the remote control.
- Do not allow anything to impact the remote control.
- Do not spill water or any liquid on the remote control.

Wall mount

Note

- Improper wall mounting may result in accident, injury or damage. If you have any query, contact Consumer Care in your country.
- Before wall mounting, make sure the wall can support the weight of your soundbar.
- Before wall mounting, you need not remove the rubber feet at the bottom of the soundbar, otherwise the rubber feet cannot be fixed back.
- Depending on the type of wall mounting, make sure that you use screws of a suitable length and diameter.
- Please check whether the USB port on the back of the soundbar is connected to a USB device. If it is found that the connected USB device affects the wall-mount, you need to use another USB device of the appropriate size.

Screw length/diameter

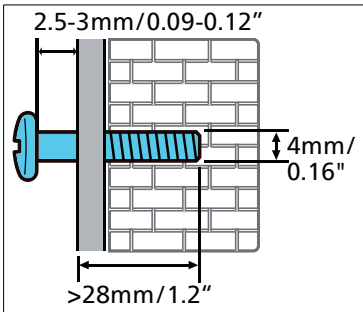

Suggested wall mounting height

You are recommended to install the TV first before wall mounting the soundbar. With a TV preinstalled, wall mount the soundbar 50mm/2.0" in distance from the bottom of the TV.

WARNING!

- To prevent injury, this apparatus must be securely attached to the floor/wall in accordance with the installation instructions.
- Suggested wall mounting height: ≤ 1.5 meters.

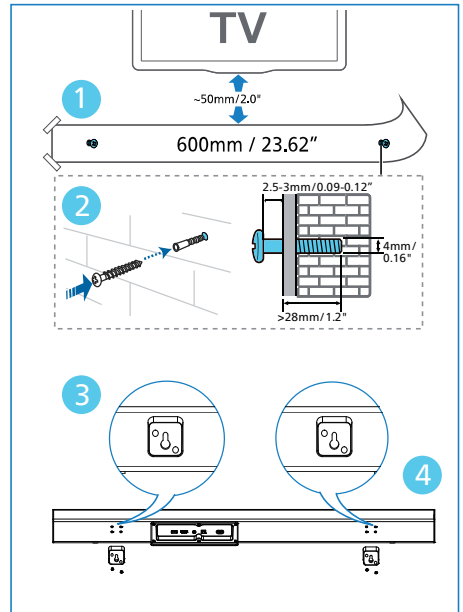

- 1 Drill 2 parallel holes (diameter 3-8mm each according to wall type) on the wall.
 - ↳ The distance between the holes are: **600mm / 23.62"**
 - ↳ You can use the wall mount template provided for helping the drilling holes position on the wall.
- 2 Secure the dowels and screws in the holes.
 - ↳ Be sure to leave a **2.5-3mm** gap between the wall and the screw's head.
- 3 Attach the wall brackets (x2) into the back of the unit.
- 4 Hang the soundbar on the fastening screws.

3 Connect

This section helps you connect your soundbar to a TV and other devices, and then set it up.

For information about the basic connections of your soundbar and accessories, see the quick start guide.

Note

- For identification and supply ratings, see the type plate at the back or bottom of the product.
- Before you make or change any connections, make sure that all devices are disconnected from the power outlet.

Note

- The Dolby Audio-Dolby Digital Plus experience is only available when the soundbar is connected to the HDMI-ARC source via a HDMI cable above 1.4.
- The soundbar will still function when connected via other methods (such as a Digital Optical cable), but these are unable to support all of the Dolby Audio-Dolby Digital Plus features. Given this, our recommendation is to connect via HDMI, in order to ensure full Dolby Audio support.

Dolby Audio-Dolby Digital Plus

Dolby Audio-Dolby Digital Plus gives you a new surround listening experience. For more information, please visit dolby.com

Use Dolby Audio-Dolby Digital Plus

Dolby Audio-Dolby Digital Plus is available in HDMI-ARC mode. For the details of the connection, please refer to "Connect to **HDMI ARC**".

- 1 To use Dolby Audio-Dolby Digital Plus in HDMI-ARC mode, your TV has to support Dolby Audio-Dolby Digital Plus.
- 2 Make sure that "No Encoding" is selected for bitstream in the digital audio output of the connected external device (e.g. Blu-ray DVD player, TV etc.).

Connect to HDMI ARC

Your soundbar supports HDMI with audio return channel (ARC). If your TV is HDMI ARC compliant, you can hear the TV audio through your soundbar by using a single HDMI cable.

- 1 On your TV, turn on HDMI-CEC operations. For details, see the TV user manual

The **HDMI ARC** connector on the TV might be labeled differently. For details, see the TV user manual.

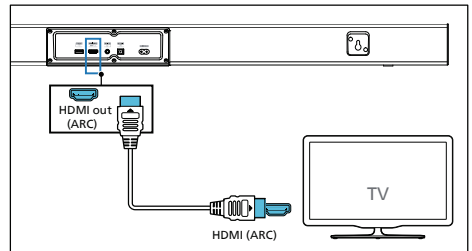

- 2 Using a High Speed HDMI cable, connect the **HDMI ARC** connector on your soundbar to the **HDMI ARC** connector on the TV.

Note

- Your TV must support the HDMI-CEC and ARC function. HDMI-CEC and ARC must be set to On.
- The setting method of HDMI-CEC and ARC may differ depending on the TV. For details about ARC function, please refer to your TV user manual.
- Make sure to use the HDMI cables that can support the ARC function.

Connect to Optical socket

- Using an optical cable, connect the **Optical** connector on your soundbar to the **Optical out** connector on the TV or other device.

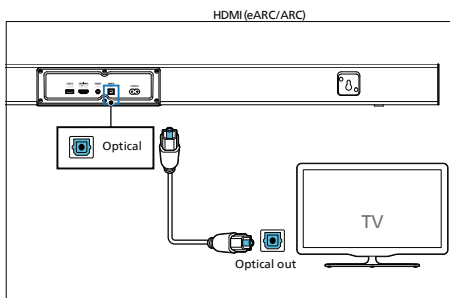

- The digital optical connector might be labeled **SPDIF** or **SPDIF OUT**.

Connect to AUX socket

- Use a 3.5mm audio cable to connect the TV's headphone socket to the AUX socket on the unit.

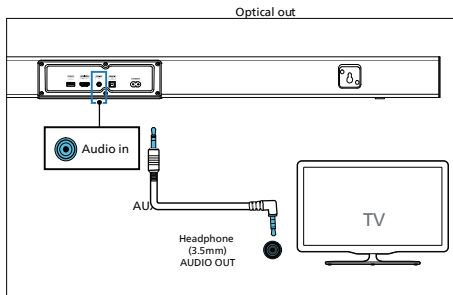

- Use an RCA to 3.5mm audio cable to connect the TV's audio output sockets to the AUX socket on the unit.

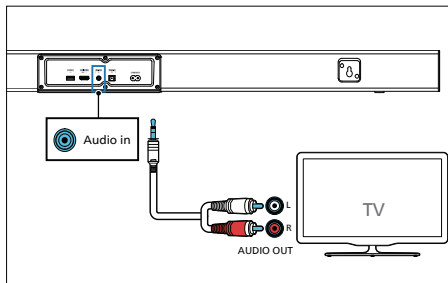

Connect to power

- Before connecting the AC power cord, ensure you have completed all other connections.
 - Risk of product damage! Ensure that the power supply voltage corresponds to the voltage printed on the back or the underside of the unit.
- 1 Connect the mains cable to the **AC~** socket of the unit and then into a mains socket.
 - 2 Connect the mains cable to the **AC~** socket of the subwoofer and then into a mains socket.

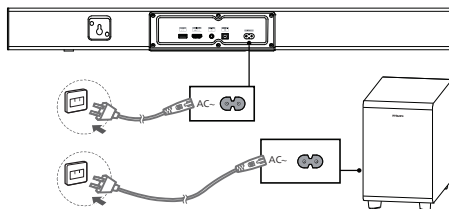

- * Power cord quantity and plug type vary by regions.

Pair up with the subwoofer

Automatic pairing

Plug the soundbar and the subwoofer into the mains sockets and then press **⏻** on the unit or remote control to switch the unit to **ON** mode. The subwoofer and soundbar will automatically be paired.

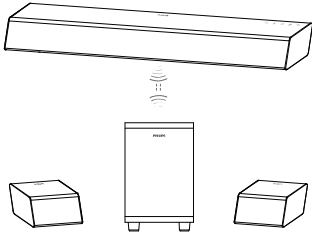

LED State	Status
Fast blink	Subwoofer in pairing mode
Constant on	Connected / Pairing successful
Slow blink	Connection / Pairing failed

Tips

- Do not press **Pair** button on the rear of the Subwoofer, except for the failure of pairing.

Manual pairing

If no audio from the wireless subwoofer can be heard, manually pair up the subwoofer.

- Unplug both the soundbar and the subwoofer from the mains sockets again, then plug them in again after 3 minutes.
- Press and hold the **Pair** button on the rear of the subwoofer for 3 seconds.
 - The indicator on the subwoofer will rapidly blink.

- Then press **⏻** on the soundbar or remote control to switch the soundbar **ON**.
 - The indicator on the subwoofer will become solid when successful.
- If the indicator still keeps blinking, repeat step 1-3.

Tips

- The subwoofer should be within 6 m of the soundbar in an open area (the closer the better).
- Remove any objects between the subwoofer and the soundbar.
- If the wireless connection fails again, check if there is a conflict or strong interference (e.g. interference from an electronic device) around the location. Remove these conflicts or strong interferences and repeat the above procedures.

Connect surround speakers to the subwoofer

Use the RCA cables to connect the surround speakers to the subwoofer, red joint to red socket and white joint to white socket.

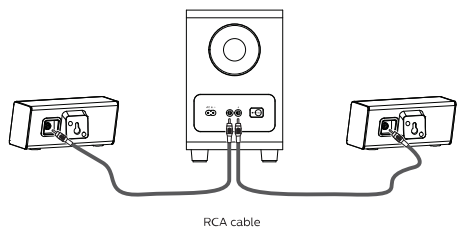

4 Use your soundbar

This section helps you use the soundbar to play audio from connected devices.

Before you start

- Make the necessary connections described in the quick start guide and the user manual.
- Switch the soundbar to the correct source for other devices.

Turn ON and OFF

- When you first connect the unit to the main socket, the unit will be in STANDBY mode. The [Standby] indicator will light up.
- Press the  button on the remote control or on the main unit to switch the main unit ON or OFF.
- Disconnect the main plug from the main socket if you want to switch the unit off completely.

Select source

Press the  button repeatedly on the unit or on the remote control to select the desired source. The Soundbar's LED display will show which source is currently in use.

Display	Status
AUX	AUX
USB	USB
STANDBY	Standby
BT NO BT	BT(Bluetooth) <ul style="list-style-type: none">• Connected• Disconnected
OPT	OPTICAL
ARC	HDMI ARC

Select equalizer (EQ) effect

Select predefined EQ effects to suit you video or music.

Press the **EQ** button on the remote control to select your desired preset equalizer effects. Default mode is Movie.



- **Movie** (Display shows MOVIE): Create a surround listening experience. Ideal for watching movies.
- **Music** (Display shows MUSIC): Create multi-channel or multichannel stereo sound. Ideal for listening to music.
- **Voice** (Display shows VOICE): Create sound effect which makes human voice more clear and outstanding for listening.
- **Stadium** (Display rolling shows STADIUM): Create an atmosphere as if watching a sports game in a stadium.

Adjust the volume

When adjusting the volume of the soundbar and subwoofer, the display will show the volume level.

Adjust the soundbar's volume

Press the **+/-** buttons on the soundbar or press  **+/-** buttons on the remote control to increase or decrease soundbar's volume level.





- To mute sound, press  on the remote control.
- To restore the sound, press  again or press the **+/-** buttons on the soundbar or press  **+/-** buttons on the remote control.





Adjust the subwoofer's volume

Press  **+/-** buttons on the remote control to increase or decrease the subwoofer's volume level.

Settings menu

The unit allows you to configure advanced settings to provide you with an even better experience.

Button	Function
	Enter settings menu
	Navigate up/down in menu structure.
	Previous/next selection
	Start, pause or resume play in USB/ BT mode; confirm the selection of the menu.
	Back to previous menu or exit menu.

- 1 Press  on the remote control to open the menu.
 - 2 Press  to select the settings.
 - 3 Press  to adjust the value of each setting.
- To return to the previous screen/ exit the settings, press .

APD (Auto Standby)

The soundbar automatically turns to Standby mode after about 15 minutes if there is no playback from any source or no operation is made or switched off.

- **ON:** Auto-Standby ON.
 - **OFF:** Auto-Standby OFF.
- ↳ By default, Auto-Standby is set to ON.

DISP (Display off)

The LED display will turn off after idling (no user action) for 3 seconds, and shall be remembered and recalled at the next power up.

- **ON:** Display off after idling (no user action) for 3 seconds.
 - **OFF:** Display won't turn off.
- ↳ By default, the display is set to ON.

DIM

Set display brightness.

- **HIGH, MID, LOW**
- ↳ By default, the dimmer is set to MID.
- ↳ By default, the Bass/Treble level is set to 0.

AURST (Audio Reset)

AURST is selected, the sound setting back to be default.

UPG (UPGRADE)

Service only, NOT applicable for end user. **UPG** is selected, insert USB disk and PLAY TO START to start firmware upgrade.

VER -X(Version)



Service only, NOT applicable for end user. **VER-X** is selected to check firmware version.

Sound effects

VRT X: DTS Digital Surround with DTS Virtual X technology to create the immersive sound effect.

AUVOL: Auto volume leveling, maintain sound stability by automatically adjusting output volume level while amplifying smaller sounds to appropriate ranges.

Night: Night mode, lower the bass to make the sound clear when listening at a low volume.

- 1 Press  on the remote control to enter sound effect menu.
- 2 Press  to select the sound effect.
- 3 Press  to exit sound effect menu.

Bass/Treble

Adjust the low frequency (bass) and high frequency (treble) settings of this product.

- **BAS -5 ... BAS +5**
- **TRB -5 ... TRB +5**

Adjust volume of each channel

Press  button on remote controller to enter sound settings menu, pressing navigation buttons to enter sounding settings to select you needed.

CENT (center channel)

Adjust the center channel volume.

- **CTR-5 ... CTR+5**
 - ↳ By default, the center channel volume is set to 0.

FL (front left channel)

- **FL-5 ...FL+5**
 - ↳ By default, the front left channel volume is set to 0

FR (front right channel)

- **FR-5 ...FR+5**
 - ↳ By default, the front right channel volume is set to 0

SL (surround left channel)

- **SL-5 ...SL+5**
 - ↳ By default, the surround left channel volume is set to 0

SR (surround right channel)

- **SR-5 ...SR+5**
 - ↳ By default, the surround right channel volume is set to 0

AV SYNC

Set the Audio Delay.

Video image processing is sometimes longer than the time required to process the audio signal. This is called "delayed." Audio Delay feature is designed to remedy this delay.

- **AV 00 ... AV 10 ... AV200**

↳ By default, the audio delay is set to 00.



Factory reset

Reset device to default setting.

- 1 Turn on the soundbar.
- 2 Press and hold + and - on the soundbar for 8 seconds. Display will show "RESET" for 5 seconds. When the system reboots, the display will show "REBOOT".



Bluetooth operation

Through Bluetooth, connect the soundbar with your Bluetooth device (such as an iPad, iPhone, iPod touch, Android phone, or laptop), and then you can listen to the audio files stored on the device through your soundbar.

- 1 Press the  button on soundbar or  on the remote control to switch the soundbar to Bluetooth mode.
→ The display will show "Pairing".
- 2 On the Bluetooth device, switch on Bluetooth, search for and select **Philips TAB7568** to start connection (see the user manual of the Bluetooth device on how to enable Bluetooth).
- 3 Wait until you hear the voice prompt from the soundbar.
→ If successfully connected, the display will show "BT".
- 4 Select and play audio files or music on your Bluetooth device.
 - During play, if a call comes in, music play pauses. Play resumes when the call ends.

- If your Bluetooth device supports AVRCP profile, on the remote control you can press ▲ / ▼ to skip to a track, or press ►|| to pause/resume play.

- 5 To disconnect Bluetooth connection and pair a new Bluetooth device:

- Press and hold the  button on the remote control or  button on the soundbar for 3 seconds to disconnect the current Bluetooth connection and enter Pairing mode.

Note

- In an open space without obstructions, the maximum operational range between the soundbar and a Bluetooth device is approximately 10 meters (30 feet).
- Compatibility with all Bluetooth devices is not guaranteed.
- The music streaming may be interrupted by obstacles between the device and soundbar, such as wall, metallic casing that covers the device, or other devices nearby that operate in the same frequency.



USB operation

Enjoy audio on a USB storage device, such as an MP3 player and USB flash memory, etc.

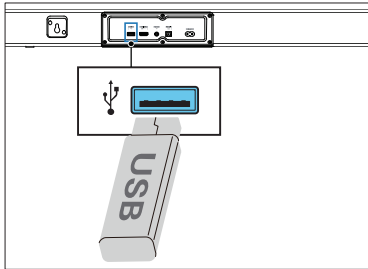
- 1 Insert the USB device.



- 2 Press the  button repeatedly on the unit or on the remote control repeatedly until the display shows "USB".
- 3 During playback:

Button	Action
	Start, pause or resume play
	Skip to the previous track
	Skip to the next track

Tips

- This product may not be compatible with certain types of USB storage devices.
- If you use a USB extension cable, USB hub, or USB Multifunctional card reader, the USB storage device may not be recognized.
- Do not remove the USB storage device during file reading.
- This product can support USB devices with up to 128 GB of memory.
- This product can play MP3, WAV, WMA, FLAC.
- Support a USB port: 5V = 500mA.

AUX / Optical / HDMI ARC operation

Ensure that the unit is connected to the TV or audio device.

- 1 Press the  button repeatedly on the unit or on the remote to select the desired source.

↳ The soundbar 's display screen will show which mode is currently in use.

Status	Display
Audio in	AUX
OPTICAL	OPT
HDMI ARC	ARC

- 2 Operate your audio device directly for playback features.
- 3 Press the +/- (volume) buttons to adjust the volume to your desired level.

Tip

- While in **Optical/HDMI ARC** mode, if there's no sound output from the unit and the status indicator flashes, you may need to activate **PCM** or **DTS** or **Dolby Digital** signal output on your source device (e.g. TV, DVD or Blu-ray player).

5 Product specifications

Note

- Specifications and design are subject to change without notice.

Bluetooth

Bluetooth profiles	A2DP, AVRCP
Bluetooth version	V 5.3
Bluetooth frequency band	2402-2480 MHz
Transmitter power	≤ 20dBm
5.8G Wireless Frequency range/ Transmitter power	5729 ~5851 MHz/ ≤ 10dBm

Amplifier section

Output power	RMS 113W @THD≤10%; Max. 226W
--------------	---------------------------------

Soundbar

Power supply	100-240V~ 50/60Hz
Power consumption	43 W
Standby consumption	< 0.5 W
USB	5V = 500mA
Frequency response	150Hz - 20KHz
Impedance	C4Ω+L8Ω+R8Ω
Dimension (W x H x D)	900x68x108 mm
Weight	2.75kg
Operating temperature	0°C - 40°C

Subwoofer

Power supply	100-240 V~ 50/60 Hz
Power consumption	70 W

Standby power consumption	< 0.5 W
Frequency response	35Hz - 150Hz
Impedance	4 Ω
Dimensions (W x H x D)	160x232x277 mm
Weight	3.35 kg
Operating temperature	0°C - 40°C

Surround speaker

Dimensions (W x H x D)	140x68x108 mm
Weight	1.1 kg
Operating temperature	0°C - 40°C

Remote control

Distance/Angle	6m/30°
Battery type	AAA (1.5V X 2)

Supported audio formats

HDMI ARC

- Dolby Digital, Dolby Digital Plus, DTS Digital Surround (DTS 5.1), DTS Virtual:X, PCM 5.1ch

Optical

- Dolby Digital, PCM 5.1ch

BLUETOOTH

- SBC

USB

- MP3, WAV, FLAC

6 Troubleshooting



Warning

- Risk of electric shock. Never remove the casing of the product.

To keep the warranty valid, never try to repair the product yourself.

If you have problems using this product, check the following points before you request service. If you still have a problem, get support at www.philips.com/support.

Main unit

The buttons on the main unit do not work.

- Disconnect from the power supply for a few minutes, and then connect again.

No power

- Ensure that the AC cord is properly connected.
- Ensure that there is power at the AC outlet.
- Press  button on the remote control or soundbar to turn the soundbar on.

Sound

No sound from the soundbar speaker.

- Connect the audio cable from your soundbar to your TV or other devices. However, you do not need a separate audio connection when:
 - the soundbar and TV are connected through HDMI ARC connection, or
 - a device is connected to the HDMI in connector on your soundbar.
- On the remote control, select the correct audio input.

- Make sure that the soundbar is not muted.
- On the remote control, select the correct audio input.
- Make sure that the soundbar is not muted.
- Reset this product to its factory settings (see "Factory reset")

Distorted sound or echo.

- If you play audio from TV through this product, make sure that the TV is muted.

No sound from the wireless subwoofer.

- Manually connect the subwoofer to the main unit.
- Increase the volume. Press Vol+ on the remote control or + on the soundbar.
- When using either of the Digital input, if there is no audio:
 - Try setting the TV output to PCM or
 - Connect directly to your Blu-ray/other sources. Some TVs do not pass through digital audio.
- Your TV may be set to variable audio output. Confirm that the audio output setting is set to FIXED or STANDARD, not VARIABLE. Refer to your TV's user manual for more detailed information.
- If using Bluetooth, ensure that the volume on your source device is turned up and that the device is not muted.
- When the playback freezes and there is no sound in Wi-Fi mode, please check whether your home network is normal.

No sound from the surround speaker.

- Unplug the RCA cable between your surround speakers and your subwoofer. Confirm your subwoofer works and has sound, with the direction of above. Connect the RCA cable from your surround speakers to your subwoofer again, red joint to red socket and white joint to white socket.

Bluetooth

A device cannot connect with the soundbar.

- The device does not support the compatible profiles required for the soundbar.
- You have not enabled the Bluetooth function of the device. See the user manual of the device on how to enable the function.
- The device is not correctly connected. Connect the device correctly.
- The soundbar is already connected with another Bluetooth device. Disconnect the connected device, and then try again.

Quality of audio play from a connected Bluetooth device is poor.

- The Bluetooth reception is poor. Move the device closer to the soundbar, or remove any obstacle between the device and the soundbar.

I can't find the Bluetooth name of this unit on my Bluetooth device.

- Ensure the Bluetooth function is activated on your Bluetooth device.
- Re-pair the unit with your Bluetooth device.

Remote control does not work.

- Before you press any playback control button, first select the correct source.
- Reduce the distance between the remote control and the unit.
- Insert the battery with its polarities (+/-) aligned as indicated.
- Replace the battery.
- Aim the remote control directly at the sensor on the front of the unit.

The soundbar turns off.

- When the unit's external input signal level is too low, the unit will turn off automatically in 15 minutes. Please increase the volume level of your external device.

The subwoofer is idle or the indicator of subwoofer does not light up.

- Please unplug power cord from the mains socket, and plug it in again after 3 minutes to reset the subwoofer.

7 Trademarks



The Adopted Trademarks HDMI, HDMI High-Definition Multimedia Interface, HDMI trade dress and the HDMI Logos are trademarks or registered trademarks of HDMI Licensing Administrator, Inc. in the United States and other countries.



Dolby, Dolby Audio, and the double-D symbol are trademarks of Dolby Laboratories Licensing Corporation. Manufactured under license from Dolby Laboratories.



For DTS patents, see <http://patents.dts.com>. Manufactured under license from DTS, Inc. or DTS Licensing Limited. DTS, Digital Surround, Virtual:X, and the DTS logo are registered trademarks or trademarks of DTS, Inc. in the United States and other countries. © 2021 DTS, Inc. ALL RIGHTS RESERVED.



The Bluetooth® word mark and logos are registered trademarks owned by Bluetooth SIG, Inc. and any use of such marks by MMD Hong Kong Holding Limited is under license. Other trademarks and trade names are those of their respective owners.



Roku, the Roku logo, Roku TV, Roku TV Ready, and the Roku TV Ready logo are trademarks and/or registered trademarks of Roku, Inc. This product is Roku TV Ready-supported in the United States, Canada, and Mexico. Countries are subject to change. For the most current list of countries in which this product is Roku TV Ready-supported, please email rokutvready@roku.com.



Specifications are subject to change without notice. Please visit www.Philips.com/support for the latest updates and documents.

Philips and the Philips Shield Emblem are registered trademarks of Koninklijke Philips N.V. and are used under license.

This product has been manufactured by and is sold under the responsibility of MMD Hong Kong Holding Limited or one of its affiliates, and MMD Hong Kong Holding Limited is the warrantor in relation to this product.

TAB7568_37_UM_V1.0

