

PHILIPS

CE235BT

User manual



Register your product and get support at
www.philips.com/support

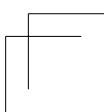
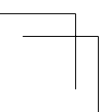
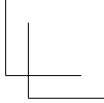
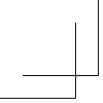

Contents

1	Safety	2	9	Charge your USB device	19
2	Your car audio system	3	10	Adjust sound	19
	Introduction	3			
	What's in the box	3			
	Overview of the system	4			
3	Install the car audio system	7	11	Adjust system settings	20
	Connect wires	7			
	Mount into the dashboard	8			
	Attach the front panel	9			
4	Get started	10	12	Additional information	20
	For the first time use	10		Reset the system	20
	Set the time format	10		Replace the fuse	20
	Set the clock	11			
	Select a source	11	13	Product information	21
	Select a listening zone	11		Product Information	21
	Mute the button beep	11			
5	Listen to radio	12	14	Troubleshooting	22
	Switch to radio mode	12		General	22
	Select a tuner region	12		About the Bluetooth device	23
	Select a tuner sensitivity	12			
	Search for a radio station	12	15	Notice	23
	Store radio stations in memory	12		Care of the environment	23
	Play with RDS	13		Trademark notice	24
				Copyright	24
6	Play from a storage device	15			
	Control play	15			
	Switch tracks	16			
7	Use Bluetooth devices	16			
	Connect a device	16			
	Play audio from a Bluetooth device	17			
	Make a call	17			
8	Listen to an external player	18			

1 Safety

Read and understand all instructions before you use this device. If damage is caused by failure to follow instructions, the warranty does not apply.

- Modification of the product could result in hazardous radiation of EMC or other unsafe operation.
- The device is designed for negative ground (earth) 12 V DC operation only.
- To ensure safe driving, adjust the volume to a safe and comfortable level.
- Improper fuses can cause damage or fire. When you need to change the fuse, consult a professional.
- Use only the supplied mounting hardware for a safe and secure installation.
- To avoid short circuits, do not expose the device to rain or water.
- The device shall not be exposed to dripping or splashing.
- Do not place any sources of danger on the device (e.g. liquid filled objects, lighted candles).
- Never insert objects into the ventilation slots or other openings on the device.
- Clean the device with soft, damp cloth. Never use substances such as alcohol, chemicals or household cleaners on the device.

2 Your car audio system

Congratulations on your purchase, and welcome to Philips! To fully benefit from the support that Philips offers, register your product at www.philips.com/welcome.

Introduction

With this system, you can:

- enjoy audio from USB storage devices, micro SD card, and other external players, and Bluetooth device.
- listen to radio stations.

You can enrich sound output with these sound effects:

- Dynamic bass boost (DBB)
- Digital sound control (DSC)

Playable media:

- USB storage device
 - Compatibility: USB 2.0, USB 1.1
 - Class support: MSC (Mass Storage Class)
 - Maximum capacity: 32 GB
- micro SD card
 - Maximum capacity: 32 GB
- .mp3 files
 - File system: FAT16, FAT32
 - Maximum number of folders: 99
 - Maximum number of tracks/files: 999
 - Maximum level of directory: 8
 - Sampling frequencies: 32 kHz, 44.1 kHz, 48 kHz
 - Bitrates: 8-320 kbps and variable bitrates
 - ID3 tag V2.0 or later
 - **Unsupported files:** AAC, WAV, and PCM files

What's in the box



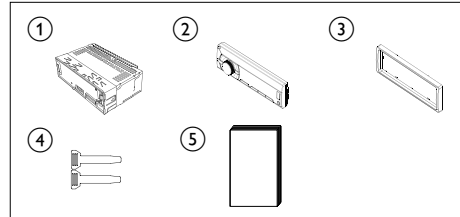

Check and identify the contents of the package:

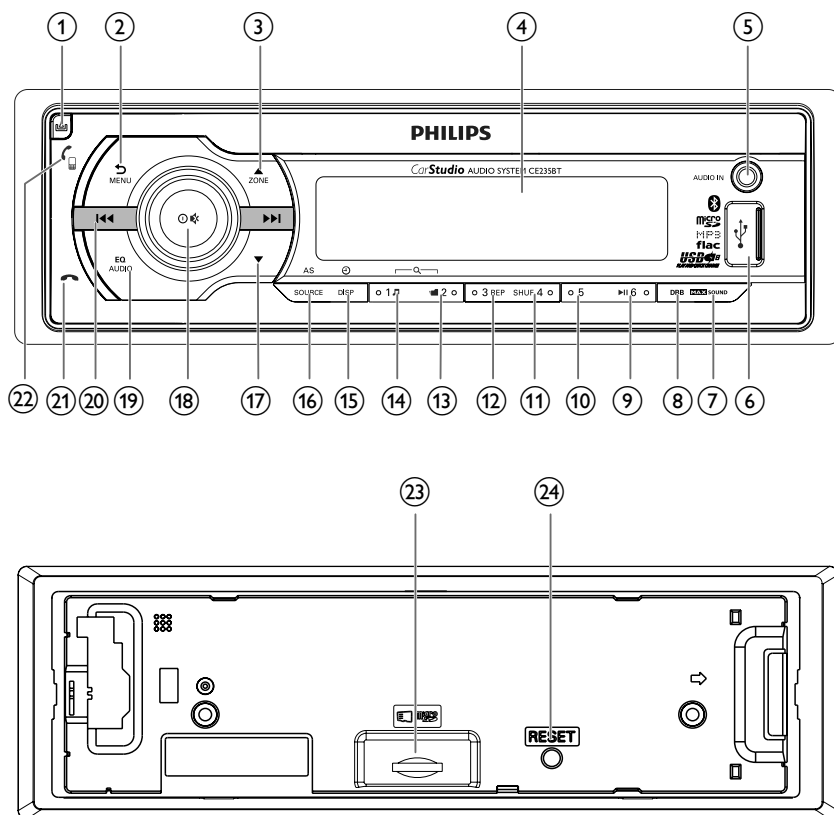

- ① Main unit (with a sleeve)
- ② Front panel
- ③ Trim plate
- ④ Disassembly tool X 2
- ⑤ User manual

Overview of the system



- ① 
 - Unlock the front panel.
- ② 
 - Press to return to the previous menu.
 - Press and hold to access the system menu.
- ③ 
 - For .mp3 tracks, press to select the previous folder.
 - In radio mode, press to select a tuner band.
 - Press and hold to activate the selection of listening zones.
- ④ LCD screen
- ⑤ AUDIO IN
 - Connect to the audio output socket (usually the headphone socket) of an external device.
- ⑥ 
 - Connect to a USB storage device.
- ⑦ **MAX SOUND**
 - Press to enable or disable the **MAX Sound** feature.

- ⑧ **DBB**
- Press to enable or disable the DBB (dynamic bass boost) sound effect.
- ⑨ **▶||6**
- Press to start, pause, or resume the play of tracks.
 - In radio mode, press to select the preset radio station of No. 6.
 - In radio mode, press and hold to store the current radio station at channel No. 6.
- ⑩ **5**
- In radio mode, press to select the preset radio station of No. 5.
 - In radio mode, press and hold to store the current radio station at channel No. 5.
- ⑪ **SHUF 4**
- In radio mode, press to select the preset radio station of No. 4.
 - In radio mode, press and hold to store the current radio station at channel No. 4.
 - For .mp3 tracks, press repeatedly to select a play mode: play all tracks randomly (**[RDM ALL]**), play tracks in the current folder randomly (**[RDM FLD]**), or play all tracks in the storage device in sequence (**[RDM OFF]**).
- ⑫ **3 REP**
- In radio mode, press to select the preset radio station of No. 3.
 - In radio mode, press and hold to store the current radio station at channel No. 3.
 - For .mp3 tracks, press repeatedly to select a repeat mode: repeat the current track (**[RPT TRK]**), repeat all tracks in the current folder (**[RPT FLD]**), or repeat all tracks in the storage device (**[RPT ALL]**).
- ⑬ **■ 2**
- In radio mode, press to select the preset radio station of No. 2.
- In radio mode, press and hold to store the current radio station at channel No. 2.
 - For .mp3 tracks, press to access the folder list.
- ⑭ **1 ↵**
- In radio mode, press to select the preset radio station of No. 1.
 - In radio mode, press and hold to store the current radio station at channel No. 1.
 - For .mp3 tracks, press to access the track list.
- ⑮ **⊕ /DSP**
- Press repeatedly to display available information about the current track.
 - Press repeatedly to display available RDS information.
 - Press and hold to display the set clock.
- ⑯ **AS/SOURCE**
- Press repeatedly to select a source.
 - In radio mode, press and hold to activate the automatic search of radio stations.
- ⑰ **▼**
- For .mp3 tracks, press to select the next folder.
 - In radio mode, press to select a tuner band.
- ⑱ **⊙ 🔊**
- Press to turn on the system.
 - Press and hold to turn off the system.
 - Press to mute the speakers or release them from mute status.
 - Press to confirm an option.
 - Rotate to switch between menu options.
 - Rotate to adjust the volume level.
- ⑲ **EQ AUDIO**
- Press repeatedly to select a preset sound equalizer.
 - Press and hold to activate the setup of bass, treble, balance, and fader.



⑳ 

- Tune to a radio station.
- Press to skip to the previous/next track.
- Press and hold to rewind a track or search fast forward.

㉑ 

- Press to hang up an ongoing call.
- Press and hold to reject an incoming call.

㉒ 

- Press to answer an incoming call.
- When it is not in a call, press  to redial the last called number; and then press  to start calling.
- In a call, press and hold to transfer the voice between the phone and the car speakers.

㉓ 

- Insert a micro SD card.

㉔ **RESET**

- Press to reset the system to factory default settings.

3 Install the car audio system

Caution

- Use the controls only as stated in this user manual.

Always follow the instructions in this chapter in sequence.

These instructions are for a typical installation. However, if your car has different requirements, make the adjustment accordingly. If you have any question regarding installation kits, consult your local retailer.

Note

- This system is designed for negative ground (earth) 12V DC operation only.
- Always install this system in the car dashboard. Other locations can be dangerous as the rear of the system heats up during use.
- To avoid short-circuit: before you connect, make sure that the ignition is off.
- Make sure that you connect the yellow and red power supply leads after all other leads are connected.
- Make sure that all loose leads are insulated with electrical tape.
- Make sure that the leads do not get caught under screws iron parts that will move (e.g. seat rail).
- Make sure that all ground (earth) leads are run to a common ground (earth) point.
- Use only the supplied mounting hardware for a safe and secure installation.
- Improper fuses can cause damage or fire. When you need to change the fuse, consult a professional.
- When you connect other devices to this system, make sure that the rating of the car circuit is higher than the total fuse value of all the connected devices.
- Never connect speaker wires to the metal body or chassis of the car.
- Never connect speaker wires with stripes to one another.

Connect wires

Note

- Make sure that all loose leads are insulated with electrical tape.
- Consult a professional to connect wires as instructed below.

1 Check the car's wiring carefully and connect them to the ISO male connectors.

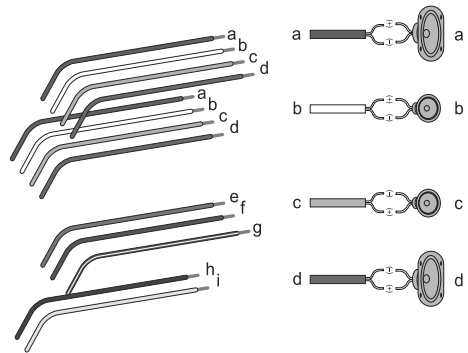

ISO male connectors	Connect to
a	Green strip, black-edged green strip Rear left speaker
b	White strip, black-edged white strip Front left speaker
c	Gray strip, black-edged gray strip Front right speaker
d	Purple strip, black-edged purple strip Rear right speaker
e	Red strip Ignition key +12V DC when ON/ACC
f	Blue strip Motor/electric antenna relay control lead
g	White-edged blue strip Amplifier relay control lead
h	Black strip Ground

	ISO male connectors	Connect to
i	Yellow strip	To the +12V car battery which is energized at all times

2 Connect the antenna and amplifier as illustrated, if applicable.

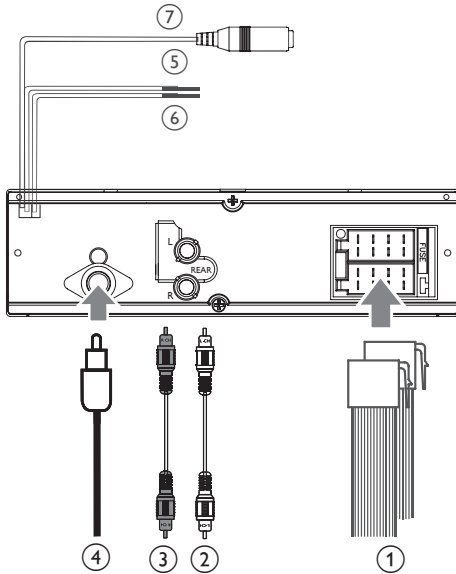

	Sockets on rear panel	External sockets or connectors
1	For ISO male connectors	As indicated above
2	REAR L	Rear left speaker
3	REAR R	Rear right speaker
4	ANTENNA	Antenna
5	Purple strip	OE remote control module
6	Black strip	Ground
7	MIC (Black Socket)	External microphone



Tip

- The pin arrangement for the ISO connectors depends on the type of your vehicle. To avoid damage to the unit, connect properly.

Mount into the dashboard

- If the car does not have an on-board drive or navigation computer, disconnect the negative terminal of the car battery.
- If the car battery is not disconnected, to avoid short-circuit, make sure that the bare wires do not touch each other.

1 Make sure that the car dashboard opening is within these measurements:

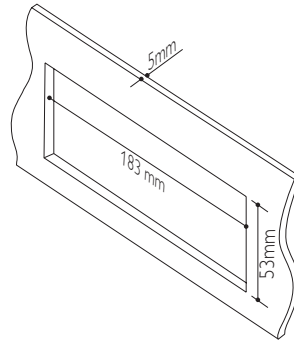

2 Remove the mounting sleeve with the supplied disassembly tools.

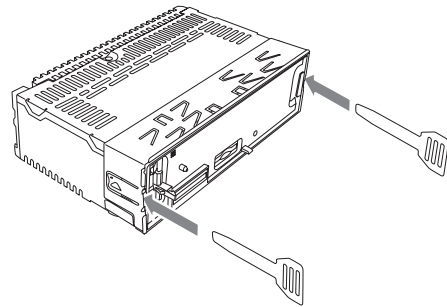

3 Install the sleeve into the dashboard and bend the tabs outward to fix the sleeve.

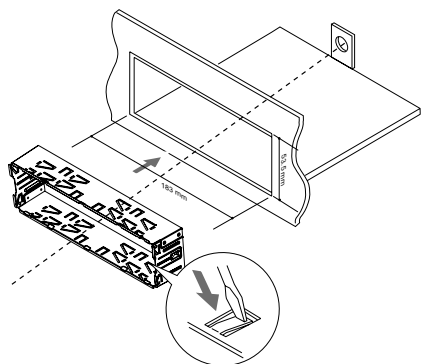

- 4 Slide the unit into the dashboard until you hear a "click".

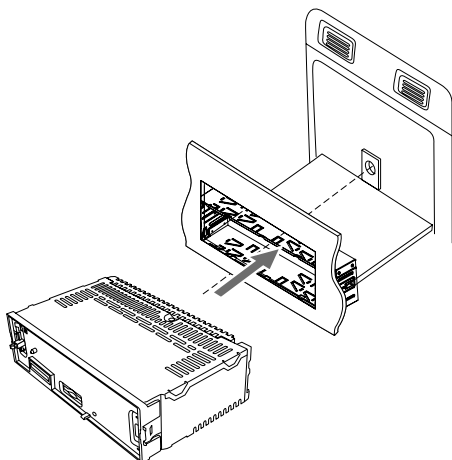

- 5 Attach the trim plate.

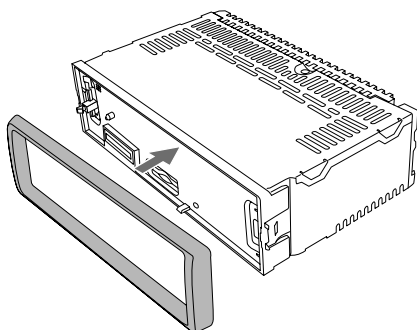

- 6 Reconnect the negative terminal of the car battery.

Attach the front panel

- 1 Insert the notch on the front panel to the chassis on the main unit.

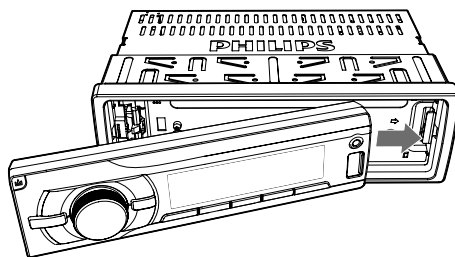

- 2 Press the left end of the front panel inwards until it is securely locked with a "click".

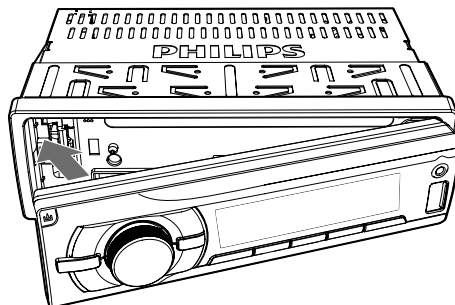

Detach the front panel

Note

- Before you insert a micro SD card or reset the system, detach the front panel.
- Before you detach the front panel, make sure that the system is turned off.

- 1 Press  to release the front panel.
- 2 Pull the front panel outwards to remove it.

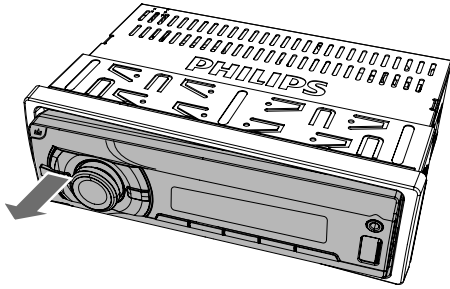

4 Get started

For the first time use

- 1 Press \odot \star to turn on the system.
↳ [PHILIPS] is displayed and then [SELECT OPERATING REGION] (select a radio region) scrolls.
- 2 When one of the following options is displayed, rotate \odot \star to select a radio region that matches your location.
 - [AREA EUROPE] (Western Europe)
 - [AREA ASIA] (Asia Pacific)
 - [AREA MID--EAST] (Middle East)
 - [AREA AUST] (Australia)
 - [AREA RUSSIA] (Russia)
 - [AREA USA] (United States)
 - [AREA LATIN] (Latin America)
 - [AREA JAPAN] (Japan)
- 3 Press \odot \star to confirm.
↳ The system switches to radio mode automatically.
 - To turn off the system, press and hold \odot \star until the screen backlight is off.

Set the time format

- 1 Press and hold \rightarrow MENU to access the system menu.
- 2 Press \triangle ZONE / ∇ repeatedly until [CLK 24H] or [CLK 12H] is displayed.
- 3 Rotate \odot \star to select [CLK 24H] or [CLK 12H].
 - [CLK 24H]: 24-hour time format
 - [CLK 12H]: 12-hour time format

Set the clock

- 1 Press and hold **MENU** to access the system menu.
- 2 Press **ZONE** / **▼** repeatedly until **[CLK]** is displayed with time digits blinking.
- 3 Rotate **◂** anti-clockwise to set the hour.
- 4 Rotate **▸** clockwise to set the minute.

Display the clock

Press and hold **DISP** until **[CLK]** and the set clock are displayed.

- To exit the clock display, press any button or rotate **◂**.

Select a source

Press **AS/SOURCE** repeatedly to select a source.

- **[RADIO]**: Listen to FM/AM radio.
- **[AUDIO IN]**: Listen to the audio input through the **AUDIO IN** socket.
- **[USB PLAY]**: When a USB storage device is connected and recognized, you can select this source to play audio files that are stored on it.
- **[SD PLAY]**: When a micro SD card is inserted and recognized, you can select this source to play audio files that are stored on it.
- **[BT AUDIO]**: Listen to the audio streamed from a connected Bluetooth device.

Select a listening zone

- 1 Press and hold **ZONE** until one of the following options is displayed.
 - **[ALL]**: For all passengers
 - **[FRONT-L]**: For the front-left seat only
 - **[FRONT-R]**: For the front-right seat only
 - **[FRONT]**: For front passengers only
- 2 Press **ZONE** / **▼** repeatedly to select a listening zone.

Mute the button beep

The beep sound of buttons is enabled by default.

- 1 Press and hold **MENU** to access the system menu.
- 2 Press **ZONE** / **▼** repeatedly until **[BEEP ON]** or **[BEEP OFF]** is displayed.
 - **[BEEP ON]**: Enable the beep sound of buttons.
 - **[BEEP OFF]**: Mute the beep sound of buttons.
- 3 Rotate **◂** to change the setting.

5 Listen to radio

Switch to radio mode

- 1 Press **AS/SOURCE** repeatedly to switch the source to **[RADIO]**.
- 2 Press **▲ / ▼** repeatedly to select a band.

Select a tuner region

You can select a radio region that matches your location.

- 1 Press and hold **≡** to access the system menu.
- 2 Press **▲ / ▼** repeatedly until one of the following options is displayed.
 - **[AREA EUROPE]** (Western Europe)
 - **[AREA ASIA]** (Asia Pacific)
 - **[AREA M--EAST]** (Middle East)
 - **[AREA AUST]** (Australia)
 - **[AREA RUSSIA]** (Russia)
 - **[AREA USA]** (United States)
 - **[AREA LATIN]** (Latin America)
- 3 Rotate **⦿** to select a region.

Select a tuner sensitivity

To search for radio stations with strong signals only or more radio stations, you can change the tuner sensitivity.

- 1 Press and hold **≡** to access the system menu.
- 2 Press **▲ / ▼** repeatedly until **[LOCAL ON]** or **[LOCAL OFF]** is displayed.
- 3 Rotate **⦿** to select a setting.
 - **[LOCAL ON]**: Search for radio stations with strong signals only.
 - **[LOCAL OFF]**: Search for radio stations with strong and weak signals.

Search for a radio station

Search for a radio station automatically

Press **⏪** or **⏩** to search for the previous or next radio station with strong signals.

Search for a radio station manually

- 1 Press and hold **⏪** or **⏩** until **[M]** blinks.
- 2 Press **⏪** or **⏩** repeatedly until the target frequency is displayed.

Store radio stations in memory



Note

- You can store a maximum of six stations in each band.

Store radio stations automatically

- 1 Press **▲ / ▼** repeatedly to select a band.
- 2 Press and hold **AS/SOURCE** until **[STORE---**] is displayed.
 - ↳ After the search is complete, the first stored radio station is broadcast automatically.
 - To select a stored radio station, press **1**, **2**, **3**, **4**, **5**, or **6**.

Store radio stations manually

- 1 Press **▲ / ▼** repeatedly to select a tuner band.
- 2 Tune to the radio station that you want to store.

- 3 Press and hold **1** **2**, **3** REP, SHUF **4**, **5**, or **▶** **6** to store the radio station at the selected channel.
- To select a stored radio station, press **1** **2**, **3** REP, SHUF **4**, **5**, or **▶** **6**.

Play with RDS

The RDS (Radio Data System) function operates only in areas with FM stations broadcasting RDS signals. If you tune to an RDS station, the station name is displayed.

Enable the RDS function



Note

- The RDS function is enabled by default.
- Only when the RDS function is enabled, RDS related settings can be accessed.

- Press and hold **≡** to access the system menu.
- Press **▲** / **▼** repeatedly until **[RDS ON]** or **[RDS OFF]** is displayed.
- Rotate **⊙** to select **[RDS ON]**.
↳ The RDS function is enabled.
 - To disable the RDS function, rotate **⊙** to select **[RDS OFF]**.

Select a program type





Before tuning to RDS stations, you can select a program type to search for programs of the selected category only.

- Press and hold **≡** to access the system menu.
- Press **▲** / **▼** repeatedly until **[PTY]** is displayed.
- Press **⊙** to access the list of program types.
- Rotate **⊙** to select a program type, and then press **⊙** to confirm.

Item	Program type	Description
1	NEWS	News services
2	AFFAIRS	Politics and current affairs
3	INFO	Special information programs
4	SPORT	Sports
5	EDUCATE	Education and advanced training
6	DRAMA	Radio plays and literature
7	CULTURE	Culture, religion and society
8	SCIENCE	Science
9	VARIED	Entertainment programs
10	POP M	Pop music
11	ROCK M	Rock music
12	EASY M	Light music
13	LIGHT M	Light classical music
14	CLASSICS	Classical music
15	OTHER M	Special music programs
16	WEATHER	Weather
17	FINANCE	Finance
18	CHILDREN	Children's programs
19	SOCIAL	Social Affairs
20	RELIGION	Religion
21	PHONE IN	Phone In
22	TRAVEL	Travel
23	LEISURE	Leisure
24	JAZZ	Jazz Music
25	COUNTRY	Country Music
26	NATION M	National Music
27	OLDIES	Oldies Music
28	FOLK M	Folk Music
29	DOCUMENT	Documentary
30	TEST	Alarm Test
31	ALARM	Alarm





Use alternate frequencies

If the signal of an RDS station is poor, enable the AF (Alternate Frequency) function to search for another station that broadcasts the same program.

- 1 Press and hold  to access the system menu.
- 2 Press  /  repeatedly until [AF ON] or [AF OFF] is displayed.
- 3 Rotate  to select a setting.
 - [AF ON]: Enable the AF function.
 - [AF OFF]: Disable the AF function.





Set the region for AF tuning

You can set the region for AF tuning.

- 1 Press and hold  to access the system menu.
- 2 Press  /  repeatedly until [REG ON] or [REG OFF] is displayed.
- 3 Rotate  to select a setting.
 - [REG ON]: Only RDS stations in current region can be tuned to automatically.
 - [REG OFF]: All RDS stations can be tuned to automatically.

Receive traffic announcement

If you want to receive traffic announcement, enable the TA (Traffic Announcement) function.

- 1 Press and hold  to access the system menu.
- 2 Press  /  repeatedly until [TA ON] or [TA OFF] is displayed.
- 3 Rotate  to select a setting.
 - [TA ON]: When a traffic announcement is on air, the system automatically switches to the tuner mode and begins to broadcast the traffic announcement. When the traffic announcement is over, the system returns to the previous mode.
 - [TA OFF]: Traffic announcement does not cut in.







Tip

- When a traffic announcement cuts in, you can press  to switch the system to the previous mode.

Synchronize the system clock

You can synchronize the system clock with an RDS station that transmits time signals.

- 1 Press and hold  to access the system menu.
- 2 Press  /  repeatedly until [CT ON] or [CT OFF] is displayed.
- 3 Rotate  to select a setting.
 - [CT ON]: Synchronize the system clock with the RDS station automatically.
 - [CT OFF]: The automatic clock synchronization with RDS station is disabled.



Tip

- The accuracy of time depends on the RDS station that transmits time signals.

6 Play from a storage device

This system can play .mp3 files that are copied onto a compatible storage device.

Note

- Philips does not guarantee compatibility with all storage devices.
- NTFS (New Technology File System) file system is not supported.

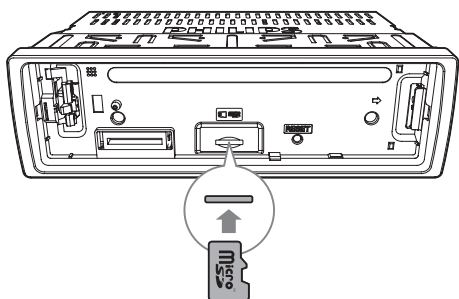
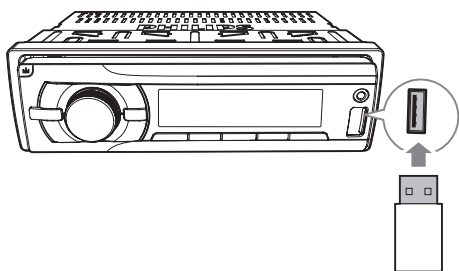







- 1 Connect a compatible USB storage device or micro SD card.
 - For a micro SD card, detach the front panel first, insert the card into the  slot, and then attach the front panel.
- 2 Press **AS/SOURCE** repeatedly to switch the source.

- **[USB PLAY]**: For a USB storage device that is connected to the USB socket on the front panel
- **[SD PLAY]**: For a micro SD card that is inserted into the  slot

- 3 If the play does not start, press **⏸**.

Control play

Button	Function
	Press repeatedly to select a folder.
	Pause or resume play.
	Press to play the previous or next track.
	Press and hold to rewind a track or search forward fast.
	Press repeatedly to display available information about the current track.
	Press repeatedly to select a repeat mode: <ul style="list-style-type: none"> • [RPT TRK]: repeat the current track, • [RPT FLD]: repeat all tracks in the current folder; or • [RPT ALL]: repeat all tracks in the storage device.
	Press repeatedly to select a play mode: <ul style="list-style-type: none"> • [RDM ALL]: play all tracks randomly, • [RDM FLD]: play tracks in the current folder randomly, or • [RDM OFF]: play all tracks in the storage device in sequence.

Switch tracks

During play, you can switch tracks or folders quickly.

Switch tracks directly

- 1 Press **1** to access the track list.
↳ The file name of current track scrolls.
- 2 Rotate **0** to toggle through tracks.
- 3 Press **0** to play the selected track.

Switch folders for a track

- 1 Press **2** to access the folder list.
↳ The name of current folder scrolls.
- 2 Rotate **0** to toggle through folders.
- 3 Press **0** to select the folder.
↳ The system starts playing the first track under the folder.

7 Use Bluetooth devices

With this car audio system, you can listen to audio from a player or make a call through Bluetooth.

Connect a device







Note

- Philips does not guarantee the compatibility with all Bluetooth devices.
- Before pairing a device with this system, read its user manual for Bluetooth compatibility.
- Make sure that Bluetooth function is enabled on your device, and your device is set as visible to all other Bluetooth devices.
- At one time, you can connect only one Bluetooth device to this system.
- The operational range between this system and a Bluetooth device is approximately 3 meters (9 feet).
- Any obstacle between this system and a Bluetooth device can reduce the operational range.
- Keep away from any other electronic device that may cause interference.

On your device, follow the steps below.

- 1 Search for Bluetooth devices.
- 2 In the device list, select **CE235BT**.
 - ↳ If the pairing succeeds, **[PAIRED]** is displayed on the LCD screen of this system.
 - ↳ If the connection succeeds, **[CONNECTED]** scrolls and **0** is displayed on the LCD screen of this system.
 - ↳ If the connection fails, **[FAILED]** is displayed on the LCD screen of this system.
 - If a password is required, enter **0000**, and then confirm the password entry. For some devices, you need to enable or permit the connection with CE235BT after successful pairing.

Disconnect a device

- 1 Press and hold  to access the system menu.
- 2 Press  /  repeatedly until **[DIS--CON]** is displayed.
- 3 Press :
 - ↳ **[WAIT]** is displayed with -, --, and --- blinking alternately until **[DISCONNECTED]** scrolls.







Tip

- You can also complete the disconnection on your device.

Reconnect a device

Some Bluetooth devices support the automatic reconnection with a paired Bluetooth device. If your device does not support automatic reconnection, reconnect it with this system manually.

- 1 Press and hold  to access the system menu.
- 2 Press  /  repeatedly until **[RE-CON]** is displayed.
- 3 Press :
 - ↳ **[WAIT]** is displayed with -, --, and --- blinking alternately until **[CONNECTED]** scrolls or **[FAILED]** appears.
 - ↳ If **[CONNECTED]** scrolls, this system is reconnected to the last connected device.





Tip

- You can also complete the reconnection on your device.

Play audio from a Bluetooth device

If the connected Bluetooth device supports Advanced Audio Distribution Profile (A2DP), you can listen to tracks that are stored on the device through the system. If the device also supports Audio Video Remote Control Profile (AVRCP) profile, you can control play on the system.

- 1 Play a track on the connected device.
- 2 Press **SOURCE** repeatedly to switch the source to **[BT AUDIO]**.
 - ↳ Play starts automatically.
 - To pause or resume play, press  6.
 - To skip to the previous or next track, press  / .



Note

- If the connected device does not support the AVRCP profile, control play on the connected device.

Make a call



Note



- Keep the Bluetooth connection active between the system and your mobile phone.

Call a number

On your mobile phone, call a number.

- ↳ **[CALLING]** is displayed.

Redial the last called number

- 1 When it is not in a call, press .
 - ↳ **[REDIAL]** is displayed.
- 2 Press  to start calling.

Pick up an incoming call

When the system receives an incoming call, the phone number or **[PHONE IN]** is displayed. Press \mathcal{C} to answer the call.

Reject an incoming call

Press and hold  until **[END]** is displayed.

End a call

To end an on-going call, press .

Transfer a call to mobile phone

By default, the voice comes from the loudspeakers during a call.

- 1 Press and hold \mathcal{C} until **[TRANSFER]** is displayed.
 - ↳ The loudspeakers are muted, and the voice comes from your mobile phone only.
- 2 Take up your mobile phone for the conversation.

8 Listen to an external player

You can use the system to amplify the audio input from an external player, for example, MP3 player.

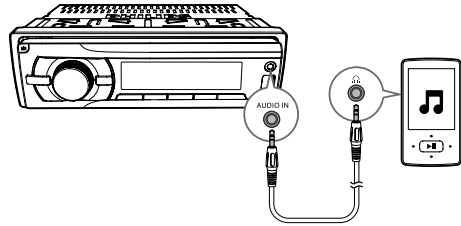

- 1 Press **AS/SOURCE** repeatedly to switch the source to **[AUDIO IN]**.
- 2 Connect an audio input cable with a 3.5 mm connector on both ends between
 - the **AUDIO IN** socket on the front panel, and
 - the audio output socket (usually the headphone socket) on the external player.
- 3 Play audio on the external player.

9 Charge your USB device

You can charge your USB device, for example, smart phone, with this product.



Note

- The output voltage through the USB socket is 5 V with output current 1.0 A.

Connect your USB device to this product with USB cable. Once the USB device is connected and recognized, it begins to charge automatically.

10 Adjust sound

The following operations are applicable to all supported media.

Button	Function
	Rotate to increase or decrease the volume level.
	Press to mute the speakers or release them from mute status.
MAX SOUND	Press to enable or disable the MAX Sound feature.
DBB	Press to enable or disable the Dynamic Bass Boost (DBB) effect.
<small>EQ AUDIO</small>	Press repeatedly to select a sound equalizer:
<small>EQ AUDIO</small>	<ol style="list-style-type: none"> 1 Press and hold to activate the setup of customized sound equalizer. 2 Press repeatedly to select an option: [BASS] (bass), [TREBLE] (treble), [BAL] (balance), [FADER] (fader), or [MIDDLE] (middle). 3 Rotate to adjust the setting.

11 Adjust system settings

- 1 Press **MENU** to access system settings.
- 2 Press **UP** or **DOWN** repeatedly until one of the following settings scrolls.
 - **[BEEP]**, **[DIMM]**, or **[DANCE]**
- 3 Rotate **OK** to change the setting.

[BEEP]	[BEEP ON]	Enable the beep sound of buttons.
	[BEEP OFF]	Disable the beep sound of buttons.
[DIMM]	[DIMMER HIGH]	Increase the brightness level of the screen.
	[DIMMER LOW]	Decrease the brightness level of the screen.
[DANCE]	[DANCE ON]	Enable the spectrum on the LCD display.
	[DANCE OFF]	Disable the spectrum on the LCD display.

12 Additional information

Reset the system

If the system works abnormally, reset the system to factory default settings.

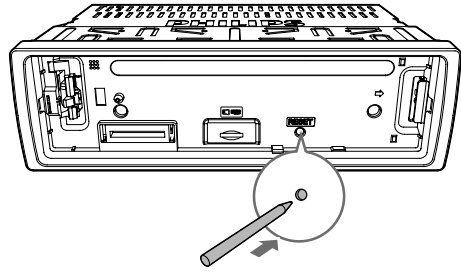

- 1 Detach the front panel.
- 2 Press the **RESET** button with the tip of a ball-point pen or toothpick.
 - ↳ All settings are reset to factory default.

Replace the fuse

If there is no power, check the fuse and replace it if it is damaged.

- 1 Check the electric connection.
- 2 Remove the damaged fuse from the rear panel.
- 3 Insert a new fuse with the same specifications (15 A).

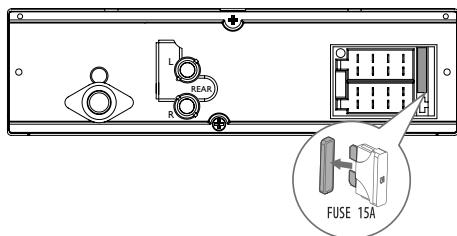

Note

- If the fuse gets damaged immediately after it is replaced, an internal malfunction may occur. In such case, consult your local retailer.

13 Product information

Note

- Product information is subject to change without prior notice.

Product Information

General

Power supply	12V DC (11V - 16V), negative ground
Fuse	15 A
Suitable speaker impedance	4 - 8 Ω
Maximum power output	50 W \times 4
Continuous power output	22 W \times 4 RMS (4 Ω 10% T.H.D.)
Pre-Amp output voltage	2.5 V
Aux-in level	\geq 500 mV
Dimensions (W \times H \times D)	188 \times 58 \times 110 mm
Weight - main unit	0.63 kg

Radio

Frequency range - FM	87.5 - 108.0 MHz (100kHz per step in auto search and 50kHz per step in manual search)
Usable sensitivity - FM (S/N = 20 dB)	8 μ V
Frequency range - AM(MW)	522 - 1620 KHz (9 kHz) 530 - 1710 kHz (10 kHz)
Usable sensitivity - AM(MW) (S/N = 20 dB)	30 μ V

Bluetooth

Output power	Class 2
Frequency band	2.4000 GHz - 2.4835 GHz ISM Band
Range	3 meters (free space)
Standard	Bluetooth 2.0 specification

14 Troubleshooting



Warning

- Never remove the casing of this product.

To keep the warranty valid, never try to repair the product yourself.

If you encounter problems when using this device, check the following points before requesting service. If the problem remains unsolved, go to the Philips Web page (www.philips.com/support). When you contact the Consumer Care, make sure that the product is nearby and the model number and serial number are available.

General

No power or no sound

- The power supply from car battery is cut off, or the car battery runs out of energy. Power the system with car battery.
- Car engine is not on. Turn the car engine on.
- Cable is not correctly connected. Check connections.
- The fuse is burnt. Replace the fuse.
- Volume is too low. Adjust volume.
- If the above solutions cannot help, press the **RESET** button.
- Make sure that the current track is in a compatible format.

Noise during broadcast

- Signals are too weak. Select other stations with stronger signals.
- Check the connection of the car antenna.
- Change the broadcast setting from stereo to mono.

Preset stations are erased.

- Battery cable is not correctly connected. Connect the battery cable to the terminal that is always live.

Display shows ERR-12.

- Data error. Check the USB storage device or micro SD card.

About the Bluetooth device

Music playback is unavailable on the system even after successful Bluetooth connection.

- The device cannot be used with the system to play music.

The audio quality is poor after connection with a Bluetooth-enabled device.

- The Bluetooth reception is poor. Move the device closer to the system or remove any obstacle between the device and the system.

Cannot connect with the system.

- The device does not support the profiles required for the system.
- The Bluetooth function of the device is not enabled. Refer to the user manual of the device to find out how to enable the function.
- The system is not in the pairing mode.
- The system is already connected with another Bluetooth-enabled device. Disconnect that device or all other connected devices and then try again.

The paired mobile phone connects and disconnects constantly.

- The Bluetooth reception is poor. Move the mobile phone closer to the system or remove any obstacle between the mobile phone and the system.
- Some mobile phones may connect and disconnect constantly when you make or end calls. This does not indicate any malfunction of the system.
- For some mobile phones, the Bluetooth connection may be deactivated automatically as a power-saving feature. This does not indicate any malfunction of the system.

15 Notice

Any changes or modifications made to this device that are not expressly approved by Philips may void the user's authority to operate the equipment.

Care of the environment

Disposal of your old product

Your product is designed and manufactured with high quality materials and components, which can be recycled and reused.



This symbol on a product means that the product is covered by European Directive 2012/19/EU. Inform yourself about the local separate collection system for electrical and electronic products. Follow local rules and never dispose of the product with normal household waste. Correct disposal of old products helps prevent negative consequences for the environment and human health.

Environmental information

All unnecessary packaging has been omitted. We have tried to make the packaging easy to separate into three materials: cardboard (box), polystyrene foam (buffer) and polyethylene (bags, protective foam sheet.)

Your system consists of materials which can be recycled and reused if disassembled by a specialized company. Please observe the local regulations regarding the disposal of packaging materials, exhausted batteries and old equipment.

EN

Compliance

Hereby, Philips declares that this product is in compliance with the essential requirements and other relevant provisions of Directive 2014/53/EU. You can find the Declaration of Conformity on www.philips.com/support.

CS

Prohlášení o shodě

Společnost Philips tímto prohlašuje, že tento výrobek vyhovuje zásadním požadavkům a dalším příslušným ustanovením směrnice 2014/53/EU. Prohlášení o shodě naleznete na webových stránkách www.philips.com/support.

DA

Overholdelse

Herved erklærer Philips, at dette produkt overholder de væsentlige krav og andre relevante bestemmelser i direktivet 2014/53/EU. Du kan se overensstemmelseserklæringen på www.philips.com/support.

DE

Prüfzeichen

Hiermit erklärt Philips, dass dieses Produkt den grundlegenden Anforderungen und anderen relevanten Bestimmungen der Richtlinie 2014/53/EU entspricht. Die Konformitätserklärung finden Sie unter www.philips.com/support.

EL

Συμμόρφωση

Με το παρόν η Philips δηλώνει ότι το προϊόν συμμορφώνεται με τις ουσιαστικές απαιτήσεις και τις λοιπές σχετικές διατάξεις της Οδηγίας 2014/53/ΕΕ. Μπορείτε να βρείτε τη Δήλωση συμμόρφωσης στη διεύθυνση www.philips.com/support.

ES

Conformidad

Por la presente, Philips declara que este producto cumple los requisitos fundamentales y otras disposiciones pertinentes de la directiva 2014/53/UE. Encontrará la declaración de conformidad en www.philips.com/support.

FI

Vaatimustenmukaisuus

Philips vakuuttaa täten, että tämä tuote on direktiivin 2014/53/EU oleellisten vaatimusten ja tuotetta koskevien direktiivin muiden säännösten mukainen. Vaatimustenmukaisuusvakuutus on saatavilla osoitteessa www.philips.com/support.

FR

Conformité

Par la présente, Philips déclare que ce produit est conforme aux exigences essentielles et autres dispositions pertinentes de la directive 2014/53/UE. La déclaration de conformité est disponible sur le site www.philips.com/support.

HU

Megfelelőség

Philips kijelenti, hogy ez a termék megfelel az 2014/53/EU irányelv lényeges előírásainak és kiegészítéseinek. A Megfelelőségi nyilatkozat a www.philips.com/support címen olvasható.

IT

Conformità

Con la presente, Philips dichiara che questo prodotto è conforme ai requisiti essenziali e ad altre disposizioni correlate della Direttiva 2014/53/UE. La Dichiarazione di conformità è presente sul sito www.philips.com/support.

NL

Compliance

Philips verklaart hierbij dat dit product voldoet aan de essentiële vereisten en andere relevante bepalingen van richtlijn 2014/53/EU. U kunt de conformiteitsverklaring lezen op www.philips.com/support.

NO

Samsvar

Philips erklærer herved at dette produktet er i samsvar med de grunnleggende kravene og øvrige relevante bestemmelser i direktiv 2014/53/EU. Du finner samsvarserklæringen på www.philips.com/support.

PL

Zgodność z przepisami

Firma Philips niniejszym oświadczam, że ten produkt spełnia wszystkie niezbędne wymagania oraz inne ważne wytyczne dyrektywy 2014/53/UE. Deklarację zgodności można znaleźć na stronie internetowej pod adresem www.philips.com/support.

PT

Conformidade

Philips declara, através deste documento, que este produto cumpre os requisitos essenciais e outras disposições relevantes da Directiva 2014/53/UE. A Declaração de Conformidade pode ser encontrada em www.philips.com/support.

RO

Conformitate

Prin prezenta, Philips declară că acest produs este în conformitate cu cerințele de bază și alte prevederi relevante ale Directivei 2014/53/UE. Declarația de conformitate este disponibilă la adresa www.philips.com/support.

SK

Súlada so smernicami

Spoločnosť Philips týmto vyhlasuje, že tento výrobok spĺňa základné požiadavky a ostatné príslušné ustanovenia Smernice 2014/53/EÚ. Vyhlásenie o zhode nájdete na stránke www.philips.com/support.

SV

Uppfyllelse

Philips deklarerar härmed att produkterna uppfyller alla viktiga krav och andra relevanta villkor i direktivet 2014/53/EG. Du hittar deklarationen om överensstämmelse på www.philips.com/support.

TR

Uyumluluk

İşbu belge ile Philips, bu ürünün 2014/53/EU Yönergesinin esas şartlarına ve ilgili hükümlerine uygun olduğunu beyan eder. Uygunluk Bildirimi'ni www.philips.com/support adresinde bulabilirsiniz.

FCC Compliance Statement: This device complies with Part 15 of the FCC rules. Operation is subjected to the following two conditions: (1) this device may not cause harmful interference, and (2) this device must accept any interference received, including interference that may cause undesired operation.

Changes or modifications not expressly approved by the party responsible for compliance could void your authority to operate the equipment.

This equipment complies with FCC radiation exposure limits set forth for an uncontrolled environment.

The distance between user and products should be no less than 20cm.

This equipment has been tested and found to comply with the limits for a Class B digital device, pursuant to Part 15 of the FCC Rules. These limits are designed to provide reasonable protection against harmful interference in a residential installation. This equipment generates, uses and can radiate radio frequency energy and, if not installed and used in accordance with the instructions, may cause harmful interference to radio communications. However, there is no guarantee that interference will not occur in a particular installation. If this equipment does cause harmful interference to radio or television reception, which can be determined by turning the equipment off and on, the user is encouraged to try to correct the interference by one or more of the following measures:

- Reorient or relocate the receiving antenna.
- Increase the separation between the equipment and receiver.
- Connect the equipment into an outlet on a circuit different from that to which the receiver is connected.
- Consult the dealer or an experienced radio/TV technician for help.



Philips and the Philips Shield Emblem are registered trademarks of Koninklijke Philips N.V. and are used under license. This product has been manufactured by and is sold under the responsibility of MMD Hong Kong Holding Limited, or one of its affiliates, and MMD Hong Kong Holding Limited, is the warrantor in relation to this product.

CE235BT_13_UM_V1.0



Séparez les éléments avant de trier