

AW5161P2 Series

2.4GHz ZigBee Wireless Communication Module

DS01010101 V1.01 Date: 2020/04/17

Product Datasheet

Overview

The AW5161P2 series ZigBee module developed by Guangzhou ZHIYUAN Electronics Co., Ltd. is a low-power and high-reliability ZigBee module based on JN516x series wireless SoC from NXP. It provides a complete application integration solution based on IEEE802.15.4 standard ISM (2.4~2.5GHz) band, supports Fastzigbee protocol, and can be quickly applied to industrial control, industrial data acquisition, agricultural control, mine personnel positioning, smart home, smart remote control and other occasions.

The AW5161P2 series ZigBee module integrates the complete RF transceiver circuit into a module, and embeds the complex communication protocol of wireless communication product into its built-in SoC, which greatly simplify the development process, make products available to the market faster, increase the competitiveness of products, so that users can better grasps the opportunities.

Applications

- ◆ Industrial control
- ◆ Industrial data acquisition
- ◆ Agricultural control
- ◆ Mine personnel positioning
- ◆ Smart home

Features

- ◆ Frequency range: 2400~2483.5MHz.
- ◆ Operating voltage: 2.0~3.6 V.
- ◆ Receiving current: 28mA
- ◆ Sleep current: 412nA
- ◆ Transmitting current: 132mA
- ◆ Max Transmitting power: 20dBm
- ◆ Receiving sensitivity: -95dBm
- ◆ Transmission speed: 250kbps
- ◆ IPEX interface, Ceramic antenna
- ◆ 3.3V interface level
- ◆ UART communication port
- ◆ Support for sleep and wake-up
- ◆ Temperature range:-40~+85℃

Ordering Information

Note: See the related product selection table.



Revision History

Version	Date	Description
V1.00	2020/04/17	Created the document.



Content

1. Introduction.....	1
1.1 Introduction.....	1
1.2 Module Naming Rule.....	1
1.3 Product Selection.....	2
2. Dimensions.....	3
3. Interface.....	4
3.1 Pin Assignment.....	4
3.2 Pin Description.....	4
4. Electrical Parameters.....	6
4.1 Operating Conditions.....	6
4.2 Operating Environment.....	6
4.3 Power consumption.....	6
5. RF Parameters.....	7
6. Production Guidance.....	8
6.1 Recommended production reflow temperature curve.....	8
6.2 Recommended production reflow temperature and time comparison table.....	8
7. Hardware Design Precautions.....	9
7.1 Smallest System.....	9
7.2 Recommended System.....	9
8. FCC Statement.....	10
9. Disclaimer.....	11

1. Introduction

1.1 Introduction

The AW5161P2 series module developed by Guangzhou ZHIYUAN Electronics Co., Ltd. is a series of low-power, high-reliability ZigBee modules based on the JN516x series wireless SoC from NXP, and provides a complete application integration solution based on IEEE802.15.4 standard ISM band. The module has been inspected and certified by authoritative RF instruments. With years of market experience and actual industry application demand, the module integrates extremely complex communication protocol into the built-in SoC, supports the transparent transmission mode of serial port, and integrates convenient and easy-to-use self-organized network function, provides multi-channel configurable AD, IO, PWM interfaces, greatly simplifying the complicated development process of wireless product, making users' product put onto the market with lower cost. Due to its ultra-small size and ultra-low power consumption, the module is widely used in a variety of smart devices.

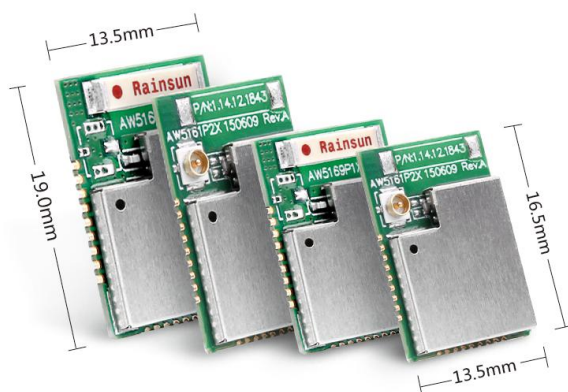

Figure 1-1: AW5161P2 series ZigBee module product image

1.2 Module Naming Rule

Figure 1-2 shows the naming rule of AW5161P2 series ZigBee module. All default factory settings of this series of module comply with the naming rule. Please confirm the model number of module is consistent with your needs before purchasing it.

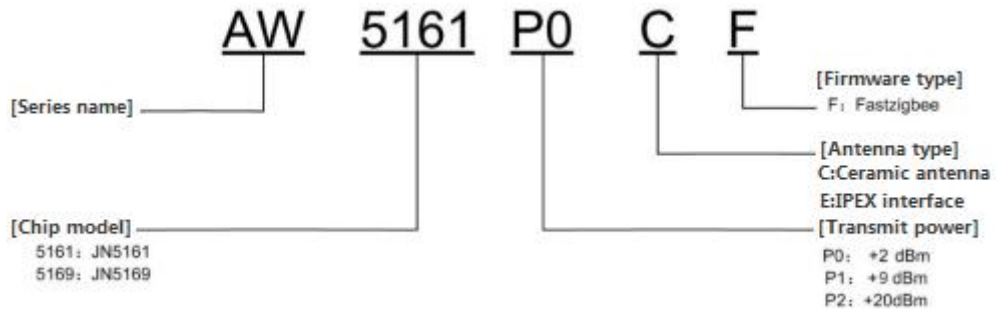

Figure 1-2: Product naming rule

1.3 Product Selection

Table 1- 1: Product model list of AW5161P2 series ZigBee module

Model	RF Interface Type	Max RF Power	Firmware	Dimensions	FCC	CE
AW5161P2EF	IPEX RF connector	+20dBm	Fastzigbee	13.5*19.0*2.25mm		
AW516P2CF	Ceramic antenna	+20dBm	Fastzigbee	13.5*19.0*2.25mm		

2. Dimensions

Please refer to Figure 2-1 for the detailed dimensions of AW5161P2 series ZigBee module.

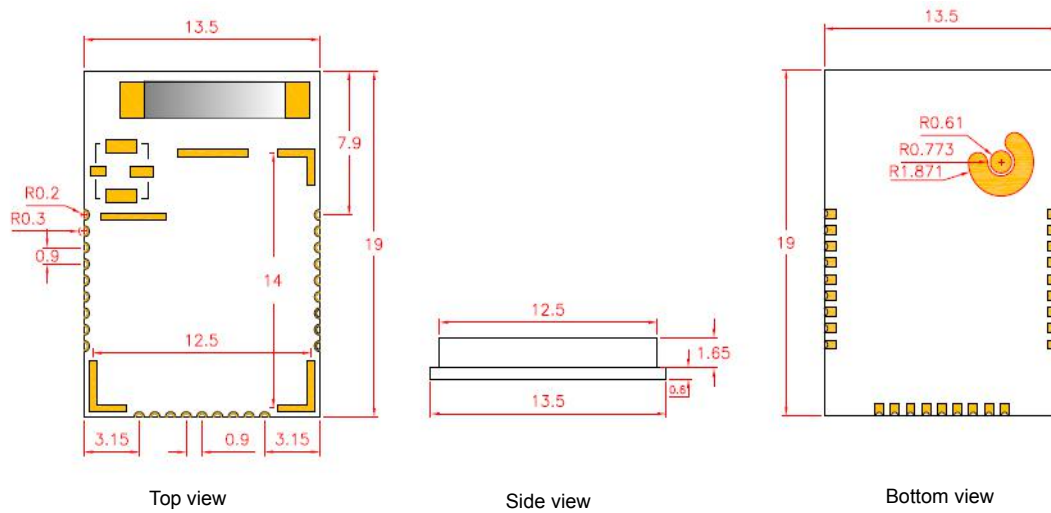

Figure 2- 1: AW5161P2 series ZigBee module dimensions (unit: mm)

3. Interface

3.1 Pin Assignment

All models of AW5161P2 series ZigBee module have same pin assignment, as shown in Figure 3-1.

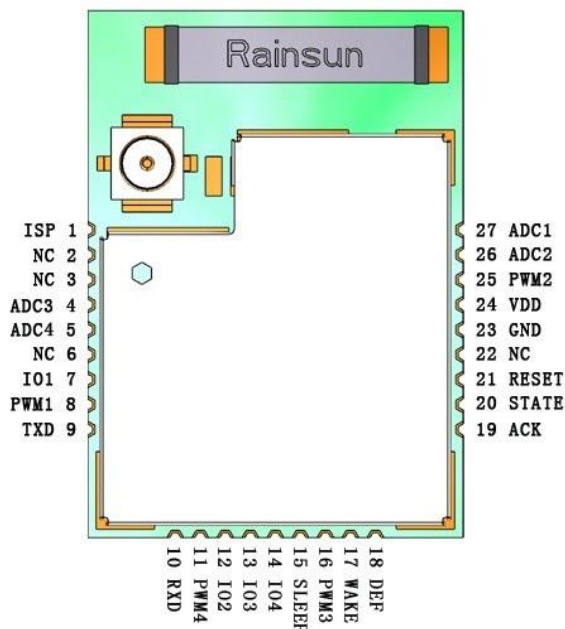

Figure 3-1: Pin assignment

3.2 Pin Description

Table 3-1 shows the pin function of AW5161P2 series ZigBee module. The description is only specially for the AW5161P2 series ZigBee module using Fastzigbee firmware.

Table 3-1: Pin description

Pin No.	Pin Name	Type	Description
1	ISP	I	Pull down the pin and reset it, and keep it low for more than 100ms after reset to enter upgrade mode.
2	NC	-	-
3	NC	-	-
4	ADC3	I	ADC input
5	ADC4	I	ADC input
6	NC	-	-
7	IO1	I/O	I/O. It is used as JOIN function when self-organized network: the coordinator allows End Devices or Router Devices to join the network, or, End Devices or Router Devices join the network through it.
8	PWM1	O	PWM output



Pin No.	Pin Name	Type	Description
9	TXD	O	Data transmitting
10	RXD	I	Data receiving
11	PWM4	O	PWM output
12	IO2	I/O	I/O, it is used as DETECT function when self-organized network: the coordinator builds the network.
13	IO3	I/O	I/O
14	IO4	I/O	I/O
15	SLEEP	I	The module enters the sleep mode when it is low level. It is only available to terminal devices.
16	PWM3	O	PWM output.
17	WAKE	I	The terminal device in the sleep mode is waked up when the fall edge occurs on the pin. The low level on the pin prevents the terminal device from entering the sleep mode.
18	DEF	I	The factory settings are restored when the pin keeps low level 3s.
19	ACK	O	ACK signal of wireless transmission.
20	STATE	O	Module networking state. Please refer to the user manual for details.
21	RESET	I	Reset. The module resets after the pin holds low level 10ms.
22	BUSY	O	Module state indication. It is high level in the case of data transmission.
23	GND	S	Ground.
24	VDD	S	DC +3.3V power supply.
25	PWM2	O	PWM output.
26	ADC2	I	ADC input.
27	ADC1	I	ADC input.



4. Electrical Parameters

4.1 Operating Conditions

Table 4- 1: Input power supply range

Parameter	Description	Min.	Typ.	Max.	Unit
VDD	Power supply of module	2.0	3.3	3.6	V

4.2 Operating Environment

Table 4-2: Temperature and humidity environment

Parameter	Name	Range	Unit
TSTG	Storage temperature	-40 to +125	°C
TA	Working temperature	-40 to +85	°C
Humidity	Relative humidity	<95	%

4.3 Power consumption

Table 4- 3: Power consumption

VDD=+3.3V; Temp=+25°C

Operating mode	Current	Remark
Sleep mode	412nA	
Transmitting mode	132mA	
Receiving mode	28mA	



5. RF Parameters

The RF characteristics of AW5161P2 series ZigBee module is listed in Table 5- 1.

Table 5- 1: RF characteristics

VDD=+3.3V; Temp=+25°C

Parameter	AW5161P2 series ZigBee module	Remark
Receiving sensitivity	-95dBm	1% PER
Maximum transmitting power	+20dBm	
Maximum receiving power	+10dBm	
Output resistance	50ohm	

6. Production Guidance

6.1 Recommended production reflow temperature curve

The AW5161P2 series ZigBee module is recommended to follow the instructions in Figure 6-1 and the solder manufacturer's guidelines during reflow soldering.

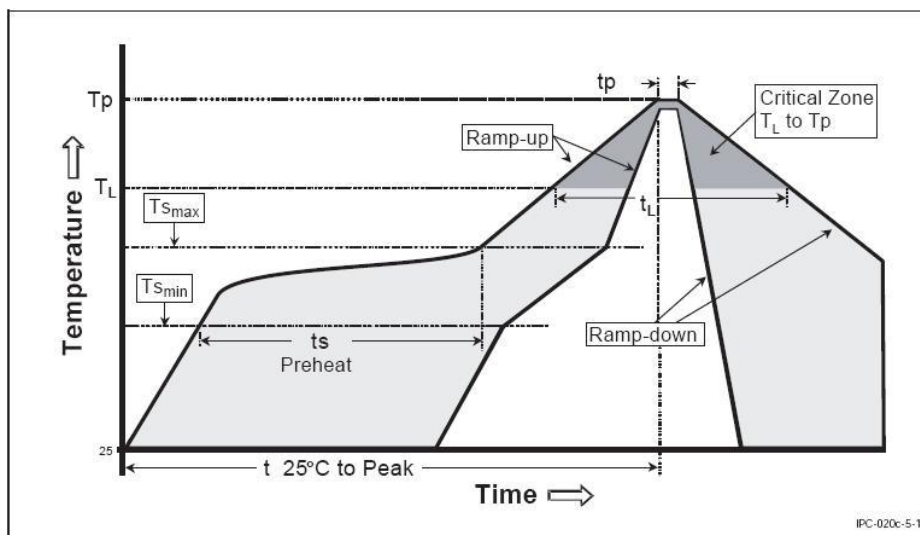

Figure 6-1: Recommended production reflow temperature curve

6.2 Recommended production reflow temperature and time comparison table

Figure 6-1 lists detailed temperature and time comparison of AW5161P2 series ZigBee module in the reflow soldering.

Table 6-1: Recommended production reflow temperature and time comparison table

Profile Feature	Sn-Pb Assembly	Pb-Free Assembly
Solder Paste	Sn63/Pb37	Sn96.5/Ag3/Cu0.5
Preheat Temperature min (Tsmmin)	100°C	150°C
Preheat Temperature max (Tsmmax)	150°C	200°C
Preheat Time (Tsmmin to Tsmmax) (ts)	60-120 sec	60-120 sec
Average ramp-up rate (Tsmmax to Tp)	3°C/second max	3°C/ second max
Liquidous Temperature (TL)	183°C	217°C
Time (tL) Maintained Above (TL)	60-90 sec	30-90 sec
Peak temperature (Tp)	220-235°C	230-245°C
Average ramp-down rate (Tp to Tsmmax)	6°C/ second max	6°C/ second max
Time 25°C to peak temperature	6 minutes max	8 minutes max

7. Hardware Design Precautions

7.1 Smallest System

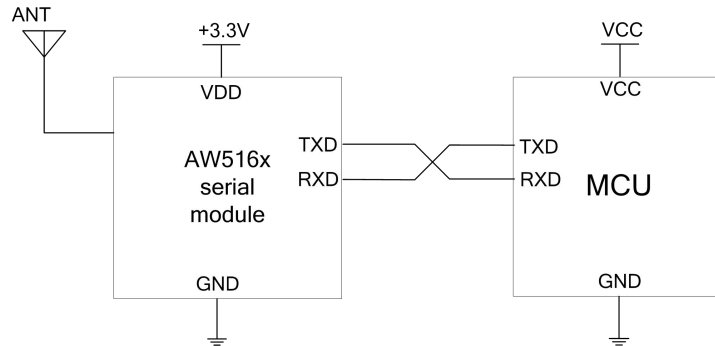

Figure 7-1: Smallest system application

7.2 Recommended System

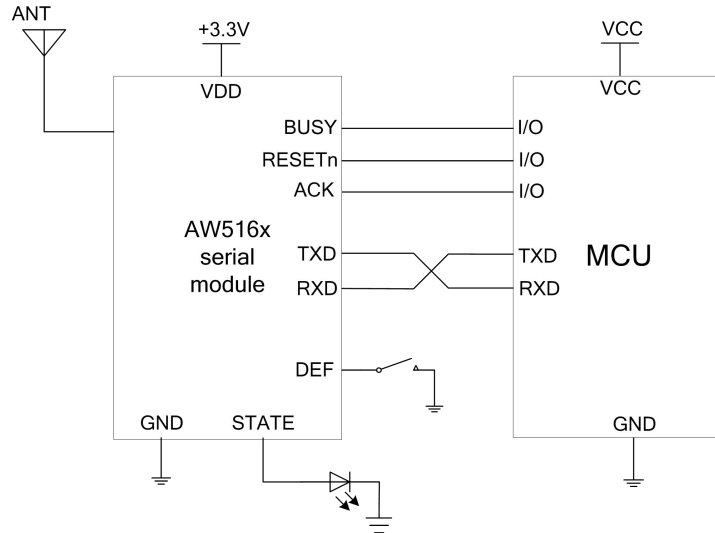

Figure 7-2: Recommended system application



8. FCC Statement

This device complies with part 15 of the FCC Rules. Operation is subject to the following two conditions: (1) This device may not cause harmful interference, and (2) this device must accept any interference received, including interference that may cause undesired operation.

Any Changes or modifications not expressly approved by the party responsible for compliance could void the user's authority to operate the equipment.

Note: This equipment has been tested and found to comply with part 15 of the FCC Rules. These limits are designed to provide reasonable protection against harmful interference in a residential installation. This equipment generates uses and can radiate radio frequency energy and, if not installed and used in accordance with the instructions, may cause harmful interference to radio communications. However, there is no guarantee that interference will not occur in a particular installation. If this equipment does cause harmful interference to radio or television reception, which can be determined by turning the equipment off and on, the user is encouraged to try to correct the interference by one or more of the following measures:

- Reorient or relocate the receiving antenna.
- Increase the separation between the equipment and receiver.
- Connect the equipment into an outlet on a circuit different from that to which the receiver is connected.
- Consult the dealer or an experienced radio/TV technician for help.

The ZigBee Wireless Transmission Module is designed to comply with the FCC statement. FCC ID is : 2AR25-AW5161P2CF The host system using ZigBee Wireless Transmission Module should have label indicated it contain module's FCC ID: 2AR25-AW5161P2CF . This radio module must not installed to colocate and operating simultaneously with other radios in host system additional testing and equipment authorization may be required to operating simultaneously with other radio.

To comply with FCC regulations limiting both maximum RF output power and human exposure to RF radiation, the maximum antenna gain including cable loss in a mobile-only exposure condition must not exceed 5dBi in the 2.4G band. The ZigBee Wireless Transmission Module and its antenna must not be co-located or operating in conjunction with any other transmitter or antenna within a host device.

RF warning for Mobile device:

This equipment complies with FCC radiation exposure limits set forth for an uncontrolled environment. This equipment should be installed and operated with minimum distance 20cm between the radiator & your body.

This device complies with Part 15, Subpart C, Section 15.247 of the FCC Rules.



9. Disclaimer

About application information

The application information in this document applies to the R&D of AW5161P2 series ZigBee module. Users shall modify and verify it based on the characteristics of their products before product development.

Rights to modify this document

The product text information and related software described in this document are all owned by Guangzhou ZHIYUAN Electronics Co., Ltd. All these property rights are protected by the national law absolutely. Without obtaining the authorization of ZHIYUAN Electronics, other companies, organizations, agencies and individuals shall not illegally copy and use the information, or else will be subject to the severe sanctions from national laws. ZHIYUAN Electronics reserves the right to modify this document at any time without any notice.

If you want to know our product and relevant information, please contact us promptly.



Sales Information

Guangzhou ZHIYUAN Electronics Stock Co., Ltd.

Address: Floor 2, Building No.7, Huangzhou Industrial Estate, Chebei Road,
Tianhe District, Guangzhou City, China

Zip Code: 510660

Website: www.zlg.com



Nationwide service hotline: 400-888-4005

Nationwide service hotline: 400-888-4005

Sales and service network:

Guangzhou Sales Office

Floor 2, Building No.7, Huangzhou Industrial Estate,
Chebei Road, Tianhe District, Guangzhou City

TEL: (020)28872342 22644261

Shanghai Branch- Shanghai

Room 12E, Jingcheng Building (E), No.668 Beijing
Road (E), Shanghai City.

TEL: (021) 53865521 53083451

Beijing Branch

Floor 19, Haojing Building A, No.108 Zhichun Road,
Haidian District, Beijing City

TEL: (010)62536178 62635573

Shanghai Branch - Nanjing

Room 1501, Pearl River Building, No.280 Pearl River
Road, Nanjing City.

TEL: (025) 68123923 68123920

Shenzhen Branch

Room 1203, Floor 12, Electronics Building, No.2072
Shennan Road (M), Futian District, Shenzhen City

TEL: (0755)83640169 83783155

Shanghai Branch - Hangzhou

Room 502, Jiangnan Electronics Building, No.217
Tianmushan Road, Hangzhou City.

TEL: (0571)89719491 89719493

Wuhan Branch

Room 12128, No.158 Luoyu Road, Guangbu
Village, Hongshan District, Wuhan City.

TEL: (027) 87168497 87168397

Chongqing Branch

Room 2705, Atlantic International Building (SEG
Electronics Market), Shiqiaopu Science and
Technology Park Road I, Chongqing City

TEL: (023)68796438 68797619

Chengdu Branch

Room 403, Digital Technology Building, No.1 Yihuan
Road, South 2nd section, Chengdu City

TEL: (028) 85439836 85432683

Xi'an Office

Room 1201, Pacific Building, No.54 Changan Road
(N), Xi'an City

TEL: (029)87881295 87881296

Please contact us with the above information. Thank you for your attention to our products!