

DC POWER CEILING FAN WALL CONTROL MANUAL

ACTIVATING THE LEARNING PROCESS

1. After installation is complete, AC power is turned on within 30 seconds, press and hold the **LEARN** button for 1~3 seconds. The receiver will make sound, Bi, once. This will indicate the receiver has learned the ID that was previously selected on the transmitter. Then the wall transmitter can control the receiver.
2. If user cannot finish the setting within the 30 seconds time frame, the main power must be turned off and re-started again. This will reset the unit. Repeat step 1 until the LEARNING feature is activated as indicated.

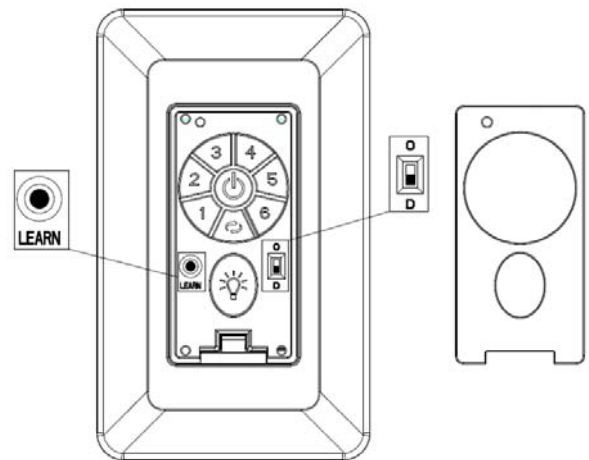

LIGHT FUNCTION SELECT SWITCH

If installed energy light onto ceiling fan, please set the “light function select switch” “light function select switch” to O position. If installed tungsten light onto ceiling fan, please set the “light function select switch” to D position.

WALL TRANSMITTER OPERATION



Press button 1~6 to set fan speed



Press this button to turn the fan off.



Press this button to set fan wind direction up or down.



ON/OFF—Press this button and release instantly to turn on or off the light.

DIMMER—Press and hold to dim or brighten lights to the desired level and release. (Tungsten bulb only)

TRANSMITTER

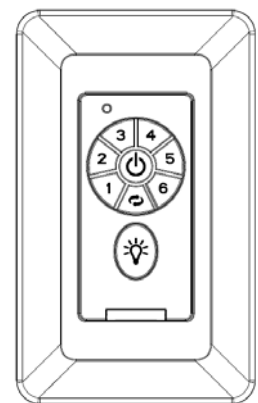

When pressing remote button, the LED indicator would be on.

Installing Wall Control (TRANSMITTER):

Remove wall plate, disconnect and remove the toggle switch from wall junction box. Using the wire connectors, make the electrical connections to the wall control (transmitter) unit. Carefully push all connected wires inside wall switch box. Secure wall control unit with 2 screws previously removed. Face plate could be locked onto the transmitter.

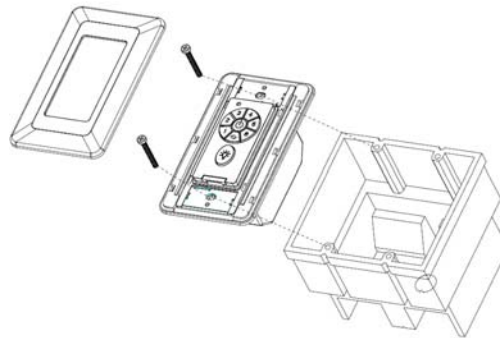

To assure continued FCC compliance:

FEDERAL COMMUNICATIONS COMMISSION INTERFERENCE STATEMENT

This equipment has been tested and found to comply with the limits for a Class B digital device, pursuant to Part 15 of the FCC Rules. These limits are designed to provide reasonable protection against harmful interference in a residential installation. This equipment generates, uses and can radiate radio frequency energy and, if not installed and used in accordance with the instructions, may cause harmful interference to radio communications. However, there is no guarantee that interference will not occur in a particular installation. If this equipment does cause harmful interference to radio or television reception, which can be determined by turning the equipment off and on, the user is encouraged to try to correct the interference by one or more of the following measures:

--Reorient or relocate the receiving antenna. --Increase the separation between the equipment and receiver. --Connect the equipment into an outlet on a circuit different from that to which the receiver is connected. --Consult the dealer or an experienced radio/TV technician for help.

CAUTION:

To assure continued FCC compliance:

Any changes or modifications not expressly approved by the grantee of this device could void the user's authority to operate the equipment.

FCC ID : 2AQZU-18023

This device complies with Part 15 of the FCC Rules. Operation is subject to the following two conditions: (1) This device may not cause harmful interference, and (2) this device must accept any interference received, including interference that may cause undesired operation.