

Abstand-Spule zur Anwendungsoberfläche  
distance coil to application surface

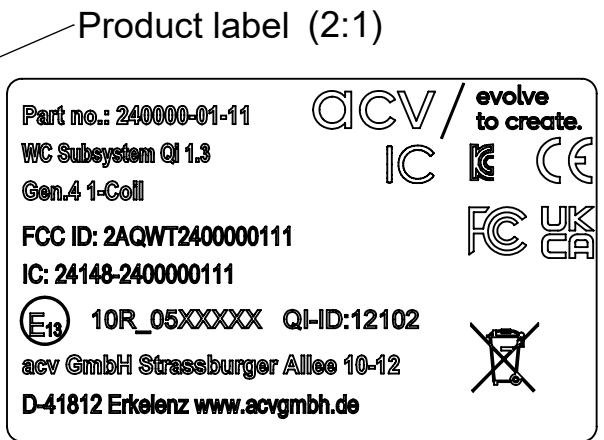

| modifications  |             |                    |            |
|----------------|-------------|--------------------|------------|
| modification n | index-clock | change description | date /name |
| —              | blank       |                    |            |

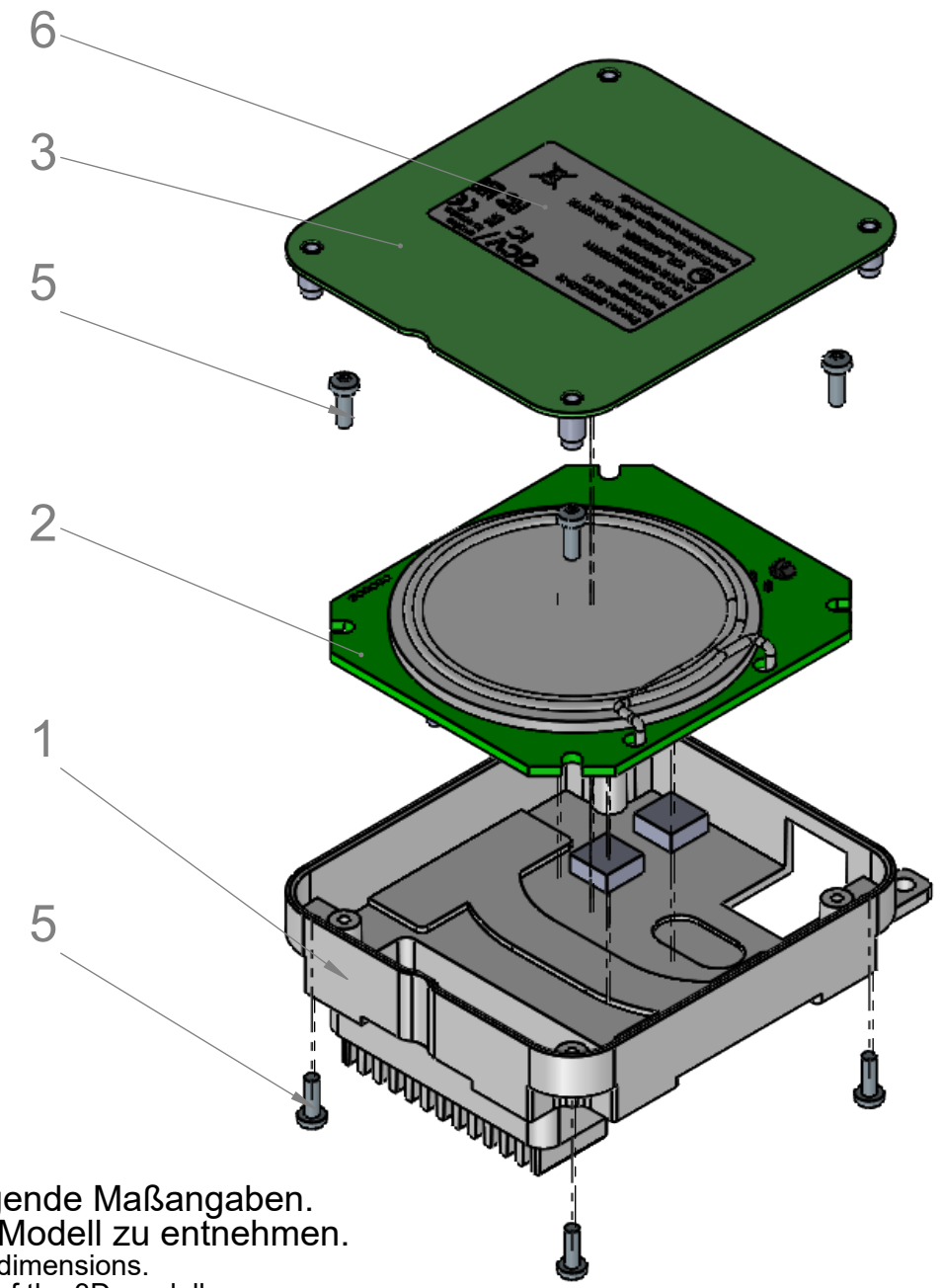

Die Zeichnung enthält nur grundlegende Maßangaben.  
 Die genaue Geometrie ist dem 3D-Modell zu entnehmen.  
 This drawing contains just the basic overall dimensions.  
 The detailed geometry should be taken out of the 3D-modell.

| pos. | part no.           | designation                               | addexplanation                   | amount |
|------|--------------------|---|----------------------------------|--------|
| 6    | 240000-01-11_Label | 15W Subsystem Qi 1.3 Label                | 240000-01-11_Label               | 1      |
| 5    | 3500117017         | Phillips pan-head screw with torx M 2 x 6 | DIN7985                          | 8      |
| 4    | IF 240000-01-11-3  | Thermal-Pad small 7x7x3mm                 | 15W/EPP qi 3 coil PCB Gen. 3 OEM | 3      |
| 3    | IF 240000-01-11-2  | Filterboard                               |                                  | 1      |
| 2    | IF 240000-01-11-1  | 1-Coil PCB 15W Qi 1.3                     |                                  | 1      |
| 1    | IF 240000-04-021   | aluminium housing 1 Coil                  |                                  | 1      |

| scale    |             | <p>pay attention to protection mark ISO 16016</p>        | general tolerances |                                     |
|----------|-------------|--|--------------------|-------------------------------------|
| 1:1      |             |  | L / Ø              | < 30 ± 0,2<br>≥ 30 ... ≤ 1000 ± 0,3 |
| material |             | drawing no.  |                    | mass [g]                            |
|          |             | 240000-01-11   |                    |                                     |
| name     |             | date   |                    | page of                             |
| drawn    | J. Hoheisel | 03.02.2022   |                    | 1 / 1                               |
| checked  |             | designation  |                    | format                              |
| modified |             | Subsystem 1Coil 15W Qi 1.3<br>Subsystem 1Coil 15W Qi 1.3 |                    | A3                                  |
| source:  |             | repl. for:   |                    | repl. by:                           |
|          |             |  |                    |                                     |

