

S1 RC Module Manual

Contents

1 Introduction.....	2
2 Technical Specification	4
3 System Diagram.....	5
4 Dimension	6
5 Pin-out definition.....	7
6 Notice	11

1 Introduction

This manual consists of technical specification, system diagram, mechanical

dimension, pin-out definition and notice.

2 Technical Specification

1	Working frequency	2.4GHz & 5.8GHz
2	Channel bandwidth	10MHz
3	Max. range	15KM
4	Transmitting power	26dBm@2.4GHz, 24dBm@5.8GHz
5	Modulation	OFDM
6	Constellation	BPSK, QPSK, 16QAM
7	FEC	LDPC (1/2, 2/3, 3/4, 5/6)
8	Duplex	TDD
10	Throughput	2Mbps ~ 10Mbps
11	Encryption	AES256
12	Serial baud rate	9600/57600/115200bps
13	Interface	Ethernet, TTL, S.bus
14	Weight	41g
15	Voltage input	TS101A: 8~12V RS101A: 18~70V

3 System Diagram

TS101A

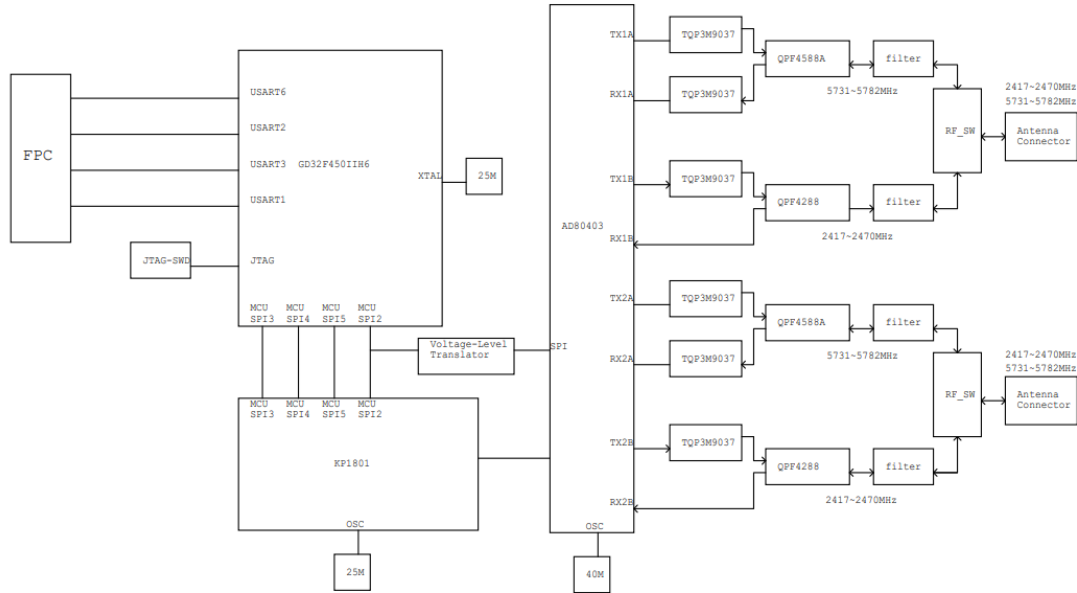

RS101A

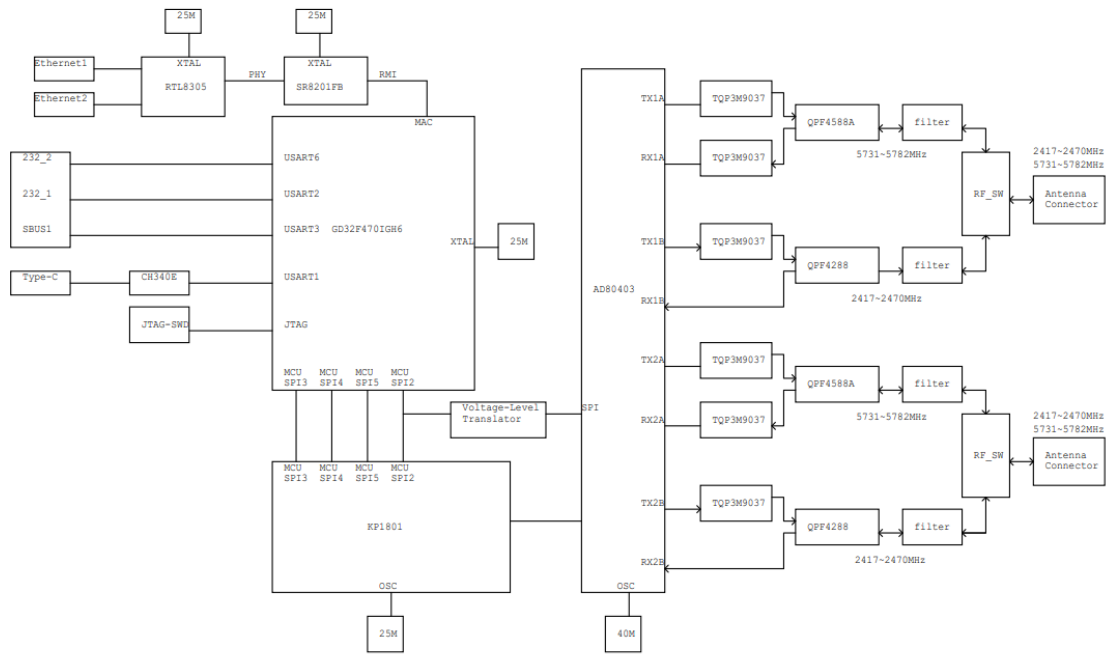

4 Dimension

AIR

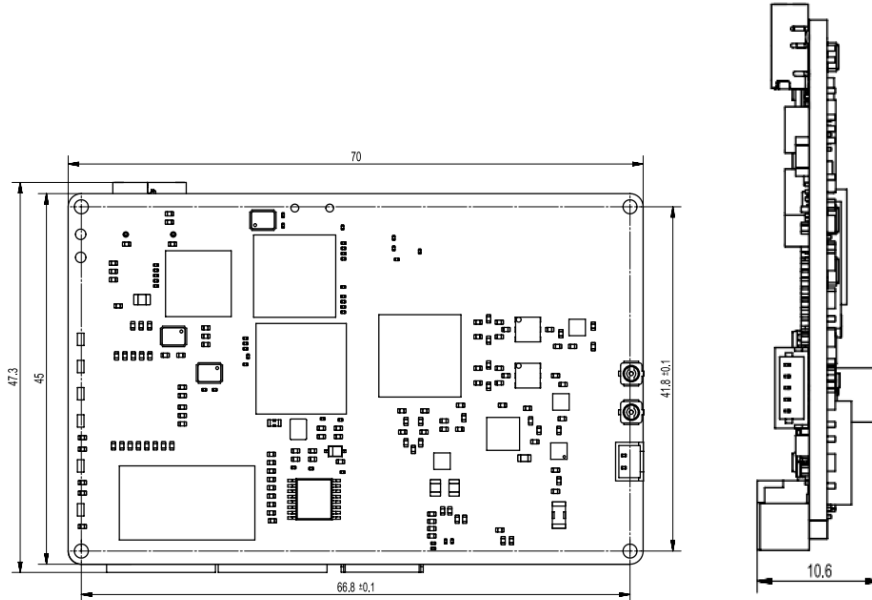

GND

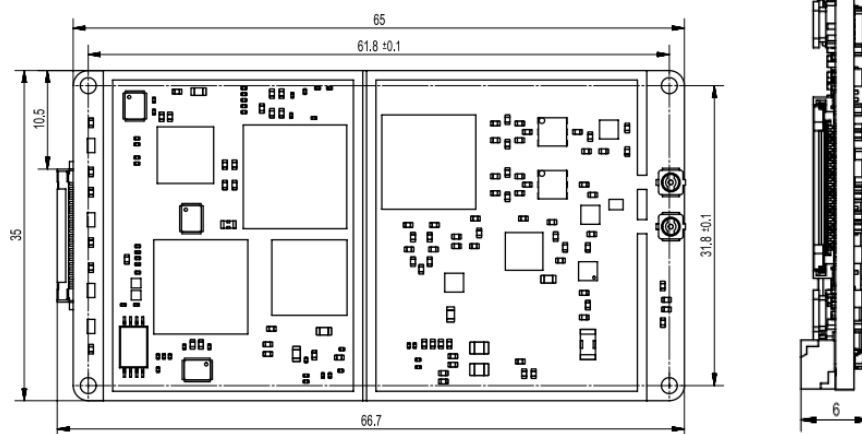

Dimension (unit: mm)

5 Pin-out definition

AIR

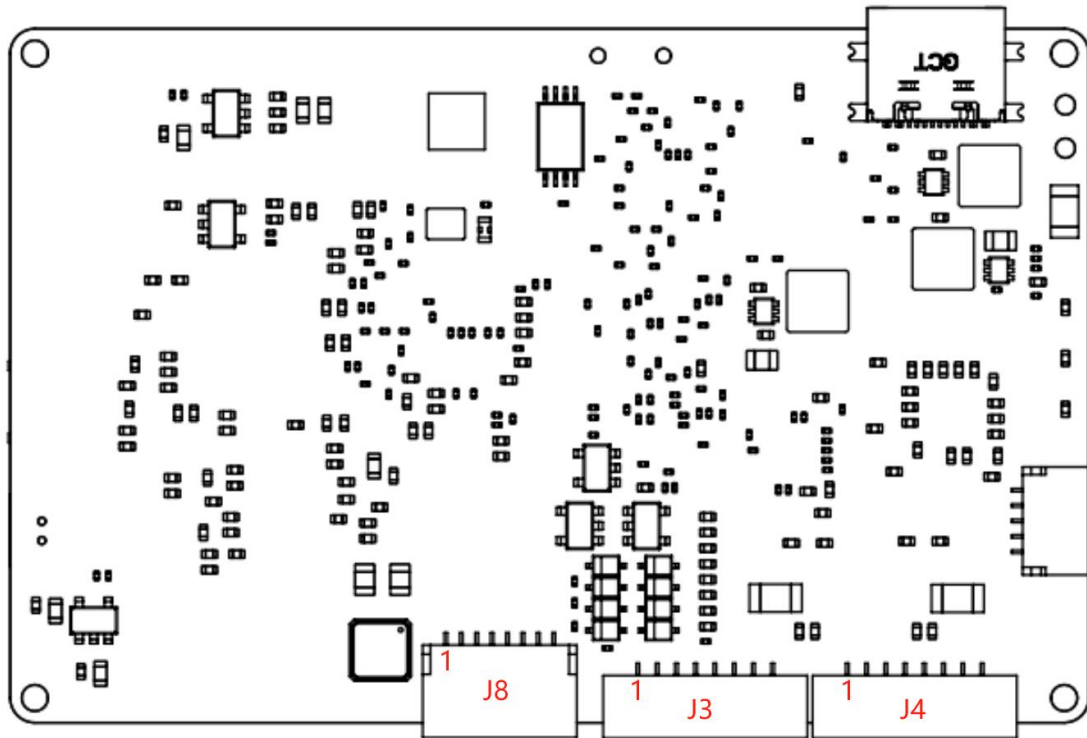

Number	Name	I/O	Voltage level	Note
J3-1	Light1_CTRL	O	TTL	Light control
J3-2	Ground	-	-	Ground
J3-3	PVIN	O	-	12V output
J3-4	Ground	-	-	Ground
J3-5	RX1N	-	-	100M Ethernet RX1N
J3-6	RX1P	-	-	100M Ethernet RX1P

J3-7	TX1N	-	-	100M Ethernet TX1P
J3-8	TX1P	-	-	100M Ethernet TX1P
J4-1	Light1_CTRL	O	TTL	Light control
J4-2	Ground	-	-	Ground
J4-3	PVIN	O	-	12V output
J4-4	Ground	-	-	Ground
J4-5	TX2N	-	-	100M Ethernet TX2N
J4-6	TX2P	-	-	100M Ethernet TX2P
J4-7	RX2N	-	-	100M Ethernet RX2N
J4-8	RX2P	-	-	100M Ethernet RX2P
J8-1	TTL/232TX1	O	TTL	Serial telemetry 1 TX
J8-2	TTL/232RX1	I	TTL	Serial telemetry 1 RX
J8-3	Ground	-	-	Ground
J8-4	TTL/232TX2	O	TTL	Serial telemetry 2 TX
J8-5	TTL/232RX2	I	TTL	Serial telemetry 2 RX
J8-6	Ground	-	-	Ground
J8-7	SBUS	O	TTL	SBUS output
J8-8	Ground	-	-	Ground

GND

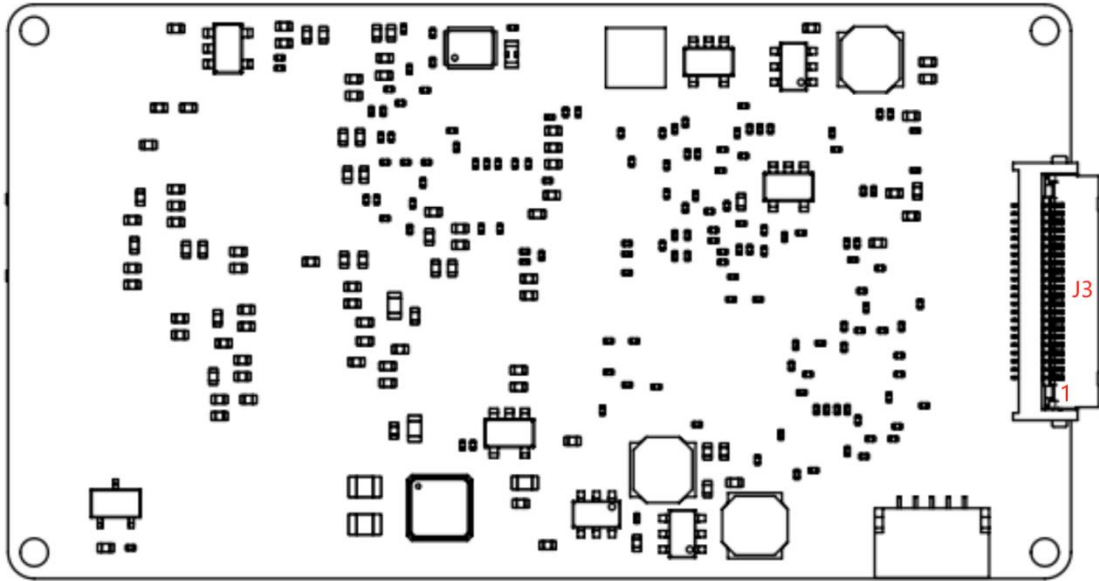

Number	Name	I/O	Voltage level	Note
J3-1	MCU_USART1_T X	O	TTL	3.3V, configuration serial port
J3-2	MCU_USART1_R X	I	TTL	3.3V, configuration serial port
J3-3	MCU_USART2_T X	O	TTL	3.3V, serial telemetry 1
J3-4	MCU_USART2_R X	I	TTL	3.3V, serial telemetry 1
J3-5	MCU_USART6_T X	O	TTL	3.3V, serial telemetry 2
J3-6	MCU_USART6_R X	I	TTL	3.3V, serial telemetry 2

J3-7	Ground			Ground
J3-8	MCU_USART3_TX	I	TTL	3.3V, can be used for S.bus
J3-9	Bind_key	I	TTL	3.3V, to trigger binding
J3_10	SYNC_IO	O	TTL	3.3V, not used
J3_11	PVIN	I	-	2S-3S voltage input
J3_12	PVIN	I	-	2S-3S voltage input
J3_13	PVIN	I	-	2S-3S voltage input
J3_14	PVIN	I	-	2S-3S voltage input
J3_15	Ground	-	-	Ground
J3_16	Ground	-	-	Ground
J3_17	Ground	-	-	Ground
J3_18	Ground	-	-	Ground
J3_19	FEA_RDN	-	-	100M Ethernet, PHY output directly without transformation
J3_20	FEA_RDP	-	-	100M Ethernet, PHY output directly without transformation
J3_21	FEA_TDN	-	-	100M Ethernet, PHY output directly without transformation
J3_22	FEA_TDP	-	-	100M Ethernet, PHY output directly without transformation

6 Notice

1) During mounting

- Please do not use metals for a chassis setting this module.
- Please do not mount parts under this module except a specified connector.

2) During operation

● The products might receive the radio wave interference from electronic devices such as Wireless LAN devices, Bluetooth devices and so on that radiate electromagnetic wave.

● Confirm that operation temperature is within the specified range described in product specification.

● Products should be used at rated voltage.

● Check the polarity of product before power on. No reverse connecting.

● No direct contacting with water, oil, acid or alkaline.

● No crushing, nail penetrating or disassembling products.

● No discarding. Dispose based on the local policy and law.

3) Storage

● No storage in a condition with a relative humidity exceeding 85% or with corrosive gases. It is easy to cause the damage and corrosion of the module, resulting in disconnection.

● For long-term storage, place the product in a well-ventilated condition at $-10^{\circ}\text{C} \sim 50^{\circ}\text{C}$, with a relative humidity below 85%.

TS101A

FCC Statement:

This device complies with Part 15 of the FCC Rules. Operation is subject to the following two

conditions:

- (1) This device may not cause harmful interference, and
- (2) this device must accept any interference received, including interference that may cause undesired operation.

This equipment has been tested and found to comply with the limits for a Class B digital device, pursuant to Part 15 of the FCC Rules. These limits are designed to provide reasonable protection against harmful interference in a residential installation. This equipment generates, uses and can radiate radio frequency energy and, if not installed and used in accordance with the instructions, may cause harmful interference to radio communications. However, there is no guarantee that interference will not occur in a particular installation. If this equipment does cause harmful interference to radio or television reception, which can be determined by turning the equipment off and on, the user is encouraged to try to correct the interference by one of the following measures:

- Reorient or relocate the receiving antenna.
- Increase the separation between the equipment and receiver.
- Connect the equipment into an outlet on a circuit different from that to which the receiver is connected.
- Consult the dealer or an experienced radio/TV technician for help.

Radiation Exposure Statement:

This equipment complies with FCC radiation exposure limits set forth for an uncontrolled environment. This equipment should be installed and operated with minimum distance 20cm between the radiator & your body.

This device is intended only for OEM integrators under the following conditions:

1) The antenna must be installed such that 20 cm is maintained between the antenna and users,

and

2) The transmitter module may not be co-located with any other transmitter or antenna.

In the event that these conditions cannot be met (for example certain laptop configurations or co-location with another transmitter), then the FCC authorization is no longer considered valid and the FCC ID cannot be used on the final product. In these circumstances, the OEM integrator will be responsible for re-evaluating the end product (including the transmitter) and obtaining a separate FCC authorization

The module is tested for standalone mobile RF exposure use condition. Any other usage conditions such as co-location with other transmitter(s) or being used in a portable

condition will need a separate reassessment through a class II permissive change application or new certification.

End Product Labeling

This transmitter module is authorized only for use in device where the antenna may be installed such that 20cm may be maintained between the antenna and users. The final end product must be labeled in a visible area with the following: “Contains FCC ID: [2AQVB-TS101A](#)”. The grantee's FCC ID can be used only when all FCC compliance requirements are met.

The end product shall bear the following 15.19 statement: This device complies with part 15 of the FCC Rules. Operation is subject to the following two conditions:

- (1) This device may not cause harmful interference, and
- (2) This device must accept any interference received, including interference that may cause undesired operation.

Antennas

The following antennas have been certified for use with this module; antennas of the same type

with equal or lower gain may also be used with this module. The antenna must be installed such

that 20 cm can be maintained between the antenna and users.

Antenna Specification list below:

Antenna Type	M/N	Frequency Band (MHz)	Antenna Gain (dBi)
Omni Antenna	ANTWRJQ24583V70JBIPX194	2400~2500 & 5150-5850	3.0
Omni Antenna	N12-7417-R0A	2400~2500 & 5150-5850	3.0

Part 15 Subpart B disclaimer

This transmitter module is tested as a subsystem and its certification does not cover the FCC Part 15 Subpart B rule requirement applicable to the final host. The final host will still need to be reassessed for compliance to this portion of rule requirements if applicable.

As long as all conditions above are met, further transmitter test will not be required. However, the OEM integrator is still responsible for testing their end-product for any additional compliance requirements required with this module installed.

Manual Information to the End User

The OEM integrator has to be aware not to provide information to the end user regarding how to install or remove this RF module in the user's manual of the end product which integrates this module. The end user manual shall include all required regulatory information/warning as show in this manual.

The host integrator must follow the integration instructions provided in this document and ensure that the composite-system end product complies with the requirements by a technical assessment or evaluation to the rules and to KDB Publication 996369.

The host integrator installing this module into their product must ensure that the final composite product complies with the requirements by a technical assessment or evaluation to the rules, including the transmitter operation and should refer to guidance in KDB 996369.

OEM/Host manufacturer responsibilities

Must use the device only in host devices that meet the FCC/ISED RF exposure category of mobile, which means the device is installed and used at distances of at least 20cm from persons.

OEM/Host manufacturers are ultimately responsible for the compliance of the Host and Module. The final product must be reassessed against all the essential requirements of the FCC rule such as FCC Part 15 Subpart B before it can be placed on the US market. This includes reassessing the transmitter module for compliance with the Radio and EMF essential requirements of the FCC rules. This module must not be incorporated into any other device or system without retesting for compliance as multi-radio and combined equipment.

Additional text needed for the host product manufacturer to provide to end users in their end-product manuals. If RF exposure statements and use conditions are not provided, then the host product manufacturer is required to take responsibility of the module through a change in FCC ID (new application).

RS101A

FCC Statement:

This device complies with Part 15 of the FCC Rules. Operation is subject to the following two

conditions:

- (1) This device may not cause harmful interference, and
- (2) this device must accept any interference received, including interference that may cause undesired operation.

This equipment has been tested and found to comply with the limits for a Class B digital

device, pursuant to Part 15 of the FCC Rules. These limits are designed to provide reasonable protection against harmful interference in a residential installation. This equipment generates, uses and can radiate radio frequency energy and, if not installed and used in accordance with the instructions, may cause harmful interference to radio communications. However, there is no guarantee that interference will not occur in a particular installation. If this equipment does cause harmful interference to radio or television reception, which can be determined by turning the equipment off and on, the user is encouraged to try to correct the interference by one of the following measures:

- Reorient or relocate the receiving antenna.
- - Increase the separation between the equipment and receiver.
- Connect the equipment into an outlet on a circuit different from that to which the receiver is connected.
- - Consult the dealer or an experienced radio/TV technician for help.

FCC Caution: Any changes or modifications not expressly approved by the party responsible for compliance could void the user's authority to operate this equipment. This transmitter must not be co-located or operating in conjunction with any other antenna or transmitter.

Radiation Exposure Statement:

This equipment complies with FCC radiation exposure limits set forth for an uncontrolled environment. This equipment should be installed and operated with minimum distance 20cm between the radiator & your body.