

RF MEASUREMENT REPORT

FCC ID: 2AQVB- RS101A
Applicant: Taisync Technology Inc.
Product: S1 RC
Model No.: RS101A
Brand Name: Viulinx
FCC Classification: Unlicensed National Information Infrastructure (NII)
FCC Rule Part(s): Part 15 Subpart E (Section 15.407)
Result: Complies
Received Date: 2023-08-28
Test Date: 2023-09-01 ~ 2023-10-20

Reviewed By:

Jame Yuan

Approved By:

Robin Wu



The test results relate only to the samples tested.

This equipment has been shown to be capable of compliance with the applicable technical standards as indicated in the measurement report and was tested in accordance with the measurement procedures specified in KDB789033. Test results reported herein relate only to the item(s) tested.

The test report shall not be reproduced except in full without the written approval of MRT Technology (Suzhou) Co., Ltd.

Revision History

Report No.	Version	Description	Issue Date	Note
2308RSU081-U2	V01	Initial Report	2023-11-10	Valid

CONTENTS

Description	Page
1. General Information	6
1.1. Applicant	6
1.2. Manufacturer.....	6
1.3. Testing Facility	6
1.4. Product Information	7
1.5. Radio Specification under Test	7
1.6. Working Frequencies.....	7
1.7. Antenna Details	7
2. Test Configuration	8
2.1. Test Mode	8
2.2. Test System Connection Diagram	8
2.3. Test Software	9
2.4. Applied Standards	9
2.5. Test Environment Condition.....	9
3. Antenna Requirements	10
4. Measuring Instrument	11
5. Decision Rules and Measurement Uncertainty	12
5.1. Decision Rules.....	12
5.2. Measurement Uncertainty	12
6. Test Result.....	13
6.1. Summary	13
6.2. 26dB & 99% Bandwidth Measurement.....	14
6.2.1. Test Limit.....	14
6.2.2. Test Procedure	14
6.2.3. Test Setting	14
6.2.4. Test Setup.....	14
6.2.5. Test Result	15
6.3. 6dB Bandwidth Measurement	16
6.3.1. Test Limit.....	16
6.3.2. Test Procedure	16
6.3.3. Test Setting	16
6.3.4. Test Setup.....	16
6.3.5. Test Result	16
6.4. Output Power Measurement.....	17
6.4.1. Test Limit.....	17

6.4.2.	Test Procedure	17
6.4.3.	Test Setting	17
6.4.4.	Test Setup	17
6.4.5.	Test Result	17
6.5.	Power Spectral Density Measurement	18
6.5.1.	Test Limit.....	18
6.5.2.	Test Procedure	18
6.5.3.	Test Setting	18
6.5.4.	Test Setup	19
6.5.5.	Test Result	19
6.6.	Frequency Stability Measurement	20
6.6.1.	Test Limit.....	20
6.6.2.	Test Procedure	20
6.6.3.	Test Setup	20
6.6.4.	Test Result	21
6.7.	Radiated Spurious Emission Measurement	22
6.7.1.	Test Limit.....	22
6.7.2.	Test Procedure	22
6.7.3.	Test Setting	22
6.7.4.	Test Setup	24
6.7.5.	Test Result	25
6.8.	Radiated Restricted Band Edge Measurement	26
6.8.1.	Test Limit.....	26
6.8.2.	Test Procedure	28
6.8.3.	Test Setting	28
6.8.4.	Test Setup	29
6.8.5.	Test Result	29
6.9.	AC Conducted Emissions Measurement.....	30
6.9.1.	Test Limit.....	30
6.9.2.	Test Setup	30
6.9.3.	Test Result	30
Appendix A – Test Result		31
A.1	Duty Cycle Test Result	31
A.2	26dB Bandwidth Test Result.....	32
A.3	6dB Bandwidth Test Result.....	34
A.4	Output Power Test Result	36
A.5	Power Spectral Density Test Result	37
A.6	Frequency Stability Test Result	39
A.7	Radiated Spurious Emission Test Result.....	41

A.8	Radiated Restricted Band Edge Test Result	49
Appendix B – Test Setup Photograph		57
Appendix C – EUT Photograph		58

1.4. Product Information

Product Name	S1 RC
Model No.	RS101A
EUT Identification No	20230828Sample#01
Wireless Specification	2417 ~ 2470MHz & 5731 ~ 5782MHz
Antenna Information	Refer to selection 1.7
Working Voltage	6S-16S (DC 18V-70V), Typically DC 24V
Operating Temperature	-10 ~ 55 °C
<p>Note 1: The information of EUT was provided by the manufacturer, and the accuracy of the information shall be the responsibility of the manufacturer.</p> <p>Note 2: There are two antenna ports of the EUT, and the two antenna ports could not transmit simultaneous.</p>	

1.5. Radio Specification under Test

Frequency Range	5731 ~ 5782MHz
Channel Number	3
Type of Modulation	OFDM
Data Rate	Upstream: 600kbps Downstream: 2.08~7.78Mbps

1.6. Working Frequencies

Low Channel	Mid Channel	High Channel
5731 MHz	5765 MHz	5782 MHz

1.7. Antenna Details

Antenna No.	Antenna Model	Antenna Type	Frequency Band (MHz)	Antenna Gain (dBi)	
				Ant 0	Ant 1
Antenna 1#	ANTWRJQ24585V50SJB	Dipole Antenna	2417 ~ 2470	5.0	5.0
			5731 ~ 5782	5.0	5.0
Antenna 2#	N12-7419-R0A	Dipole Antenna	2417 ~ 2470	5.0	5.0
			5731 ~ 5782	5.0	5.0

Note 1: The antenna gain is from antenna data sheet provided by the manufacturer.

Note 2: We choose Antenna 1# to test for this report.

2. Test Configuration

2.1. Test Mode

Mode 1: Transmit at 5731MHz - SISO Mode (Ant 0).
Mode 2: Transmit at 5765MHz - SISO Mode (Ant 0).
Mode 3: Transmit at 5782MHz - SISO Mode (Ant 0).
Mode 4: Transmit at 5731MHz - SISO Mode (Ant 1).
Mode 5: Transmit at 5765MHz - SISO Mode (Ant 1).
Mode 6: Transmit at 5782MHz - SISO Mode (Ant 1).

2.2. Test System Connection Diagram

The device was tested per the guidance ANSI C63.10: 2013 was used to reference the appropriate EUT setup for radiated emissions testing.

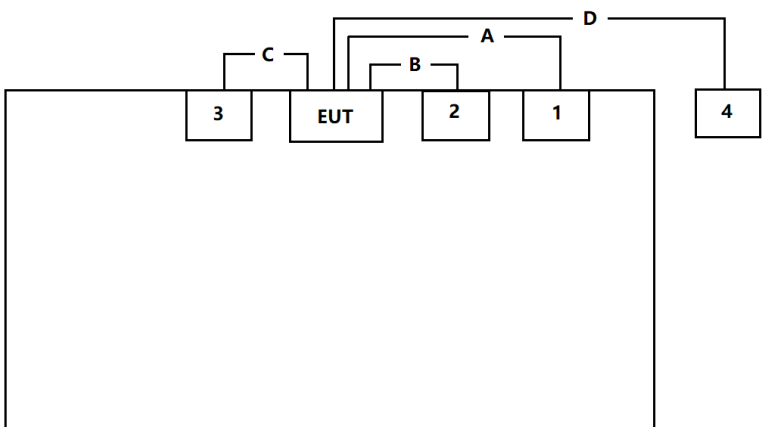
Connection Diagram			
 <p>The diagram shows a central box labeled 'EUT'. To its left are three boxes labeled '3', '2', and '1'. To its right is a box labeled '4'. Cable 'C' connects '3' to 'EUT'. Cable 'B' connects '2' to 'EUT'. Cable 'A' connects '1' to 'EUT'. Cable 'D' connects 'EUT' to '4'.</p>			
Cable Type	Cable Description		Length
A	Power Cable	Non shielded	1.8m
B	Signal Cable	Non shielded	0.16m
C	Signal Cable	Non shielded	0.75m
D	Type-C Cable	Shielding	>10m
Product	Manufacturer	Model No.	
1	Adapter	FLYPOWER	PS12T120K1000ED
2	Radio Link	PIXHAWK	N/A
3	Camera	N/A	N/A
4	Notebook	Lenovo	E430C

2.3. Test Software

The test utility software used during testing was “IPOP”, and the version was 4.1.

Note: Final power setting please refer to operational description.

2.4. Applied Standards

According to the specifications of the manufacturer, the EUT must comply with the requirements of the following standards:

- FCC Part 15.407
- KDB 789033 D02v02r01
- ANSI C63.10-2013

2.5. Test Environment Condition

Ambient Temperature	15 ~ 35°C
Relative Humidity	20 ~ 75%RH

3. Antenna Requirements

Excerpt from §15.203 of the FCC Rules/Regulations:

“An intentional radiator antenna shall be designed to ensure that no antenna other than that furnished by the responsible party can be used with the device. The use of a permanently attached antenna or of an antenna that uses a unique coupling to the intentional radiator shall be considered sufficient to comply with the provisions of this section.”

- The product is defined as the professional installation of equipment by the manufacturer, there is no necessary to comply with the requirement of §15.203.

4. Measuring Instrument

Instrument	Manufacturer	Model No.	Asset No.	Cali. Interval	Cali. Due Date	Test Site
EMI Test Receiver	R&S	ESR7	MRTSUE06001	1 year	2023-12-28	WZ-AC1
Signal Analyzer	Keysight	N9010B	MRTSUE06607	1 year	2023-12-28	WZ-AC1
Loop Antenna	Schwarzbeck	FMZB 1519	MRTSUE06025	1 year	2024-09-17	WZ-AC1
Horn Antenna	Schwarzbeck	BBHA 9120D	MRTSUE06023	1 year	2024-08-09	WZ-AC1
Horn Antenna	Schwarzbeck	BBHA 9170	MRTSUE06597	1 year	2023-11-05	WZ-AC1
Preamplifier	Agilent	83017A	MRTSUE06076	1 year	2024-05-07	WZ-AC1
Preamplifier	EMCI	EMC184045SE	MRTSUE06640	1 year	2024-01-12	WZ-AC1
Thermohygrometer	testo	608-H1	MRTSUE06403	1 year	2024-05-31	WZ-AC1
Thermohygrometer	testo	608-H1	MRTSUE11039	1 year	2023-11-01	WZ-AC1
Anechoic Chamber	TDK	WZ-AC1	MRTSUE06212	1 year	2024-04-20	WZ-AC1
EMI Test Receiver	Agilent	N9038A	MRTSUE06125	1 year	2024-05-23	WZ-AC2
TRILOG Antenna	Schwarzbeck	VULB 9162	MRTSUE06022	1 year	2024-05-15	WZ-AC2
Thermohygrometer	Mingle	ETH529	MRTSUE06170	1 year	2023-11-27	WZ-AC2
Thermohygrometer	testo	608-H1	MRTSUE11038	1 year	2023-11-01	WZ-AC2
Anechoic Chamber	RIKEN	WZ-AC2	MRTSUE06213	1 year	2024-04-20	WZ-AC2
USB Power Sensor	Keysight	U2021XA	MRTSUE06446	1 year	2024-05-23	WZ-SR4
Signal Analyzer	Keysight	N9010B	MRTSUE06457	1 year	2024-05-23	WZ-SR4
Attenuator	MVE	MVE2213	MRTSUE11088	1 year	2024-06-08	WZ-SR4
Shielding Room	HUAMING	WZ-SR4	MRTSUE06441	N/A	N/A	WZ-SR4
Temperature Chamber	BAOYT	BYH-150CL	MRTSUE06051	1 year	2024-09-27	WZ-TR3
Signal Analyzer	Keysight	N9010B	MRTSUE06457	1 year	2024-05-23	WZ-TR3
Attenuator	MVE	MVE2213	MRTSUE11088	1 year	2024-06-08	WZ-TR3
Thermohygrometer	testo	608-H1	MRTSUE06401	1 year	2024-05-31	WZ-TR3

Software	Version	Function
EMI Software	V3.0.0	EMI Test Software
Controller_MF 7802	2.03C	RE Antenna & Turntable
Controller_MF 7802	1.02	RE Antenna & Turntable
BenchVue Power Meter	2018.1	Power

5. Decision Rules and Measurement Uncertainty

5.1. Decision Rules

The Decision Rule is based on Simple Acceptance in accordance with ISO Guide 98-4: 2012 Clause 8.2. (Measurement uncertainty is not taken into account when stating conformity with a specified requirement.)

5.2. Measurement Uncertainty

Where relevant, the following test uncertainty levels have been estimated for tests performed on the EUT as specified in CISPR 16-4-2. This uncertainty represents an expanded uncertainty expressed at approximately the 95% confidence level using a coverage factor of $k = 2$.

Radiated Emission Measurement
<p>The maximum measurement uncertainty is evaluated as:</p> <p>Coaxial: 9kHz~30MHz: 2.61dB</p> <p>Coplanar: 9kHz~30MHz: 2.62dB</p> <p>Horizontal: 30MHz~200MHz: 3.79dB 200MHz~1GHz: 3.91dB 1GHz~40GHz: 4.99dB</p> <p>Vertical: 30MHz~200MHz: 4.06dB 200MHz~1GHz: 5.21dB 1GHz~40GHz: 4.90dB</p>
Spurious Emissions, Conducted
<p>Measuring Uncertainty for a Level of Confidence of 95% ($U=2Uc(y)$): 2.2dB</p>
Output Power
<p>Measuring Uncertainty for a Level of Confidence of 95% ($U=2Uc(y)$): 1.4dB</p>
Power Spectrum Density
<p>Measuring Uncertainty for a Level of Confidence of 95% ($U=2Uc(y)$): 2.2dB</p>
Occupied Bandwidth
<p>Measuring Uncertainty for a Level of Confidence of 95% ($U=2Uc(y)$): 2.7%</p>

6. Test Result

6.1. Summary

FCC Section(s)	Test Description	Test Condition	Verdict
15.407(a)	26dB Bandwidth	Conducted	Pass
15.407(e)	6dB Bandwidth		Pass
15.407(a)(3)(i)	Maximum Conducted Output Power		Pass
15.407(g)	Frequency Stability		Pass
15.407(a)(3)(i), (12)	Peak Power Spectral Density		Pass
15.407(b)(4)(i)	Undesirable Emissions		Pass
15.205, 15.209 15.407(b)(8), (9), (10)	General Field Strength Limits (Restricted Bands and Radiated Emission Limits)	Radiated	Pass
15.207	AC Conducted Emissions 150kHz - 30MHz	Line Conducted	N/A

Notes:

- The analyzer plots shown in this section were all taken with a correction table loaded into the analyzer. The correction table was used to account for the losses of the cables and attenuators used as part of the system to connect the EUT to the analyzer at all frequencies of interest.
- For radiated emission test, every axis (X, Y, Z) was also verified. The test results shown in the following sections represent the worst-case emissions.
- “N/A” means this item is not applicable, and the details refer to relevant section.

6.2. 26dB & 99% Bandwidth Measurement

6.2.1. Test Limit

N/A

6.2.2. Test Procedure

KDB 789033 D02v02r01- Section II)C)1) (26dB Bandwidth)

KDB 789033 D02v02r01- Section II)D) (99% Bandwidth)

6.2.3. Test Setting

26dB Bandwidth

1. The analyzers' automatic bandwidth measurement capability was used to perform the 26dB bandwidth
2. RBW = approximately 1% of the emission bandwidth.
3. VBW > RBW
4. Detector = Peak.
5. Trace mode = max hold.
6. Measure the maximum width of the emission that is 26 dB down from the maximum of the emission.
Compare this with the RBW setting of the analyzer. Readjust RBW and repeat measurement as needed until the RBW/EBW ratio is approximately 1%.

99% Bandwidth

1. Set center frequency to the nominal EUT channel center frequency.
2. RBW = 1% to 5% of the OBW
3. VBW $\geq 3 \times$ RBW
4. Span = 1.5 times to 5 times the OBW
5. Detector = peak
6. Trace mode = max hold
7. Allow the trace to stabilize
8. Use the 99% power bandwidth function of the instrument.

6.2.4. Test Setup

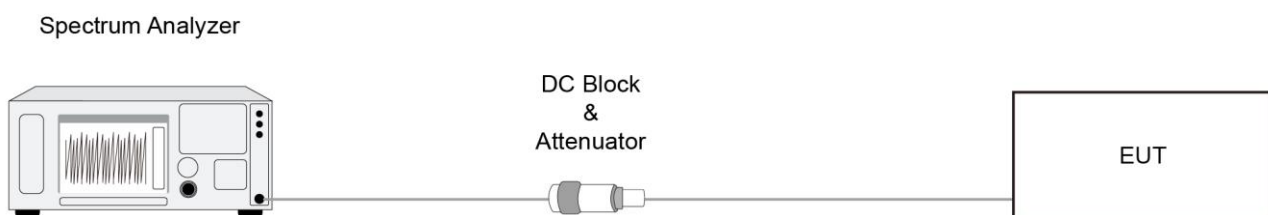

6.2.5. Test Result

Refer to Appendix A.2.

6.3. 6dB Bandwidth Measurement

6.3.1. Test Limit

The minimum 6dB bandwidth shall be at least 500 kHz.

6.3.2. Test Procedure

KDB 789033 D02v02r01- Section II(C)2)

6.3.3. Test Setting

1. Set center frequency to the nominal EUT channel center frequency.
2. RBW = 100 kHz.
3. VBW $\geq 3 \times$ RBW.
4. Detector = Peak.
5. Trace mode = max hold.
6. Sweep = auto couple.
7. Allow the trace to stabilize.
8. Measure the maximum width of the emission that is constrained by the frequencies associated with the two outermost amplitude points (upper and lower frequencies) that are attenuated by 6 dB relative to the maximum level measured in the fundamental emission.

6.3.4. Test Setup

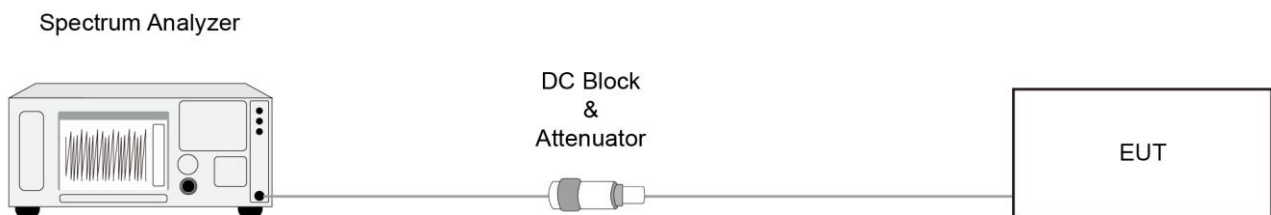

6.3.5. Test Result

Refer to Appendix A.3.

6.4. Output Power Measurement

6.4.1. Test Limit

For the band 5.725-5.85 GHz, the maximum conducted output power over the frequency band of operation shall not exceed 1 W (30dBm).

If transmitting antennas of directional gain greater than 6dBi are used, the maximum conducted output power shall be reduced by the amount in dB that the directional gain of the antenna exceeds 6dBi.

6.4.2. Test Procedure

KDB 789033D02v02r01- Section II)E)3)b) Method PM-G

6.4.3. Test Setting

Average Power Measurement

Average power measurements were performed only when the EUT was transmitting at its maximum power control level using a broadband power meter with a pulse sensor. The power meter implemented triggering and gating capabilities which were set up such that power measurements were recorded only during the ON time of the transmitter.

6.4.4. Test Setup

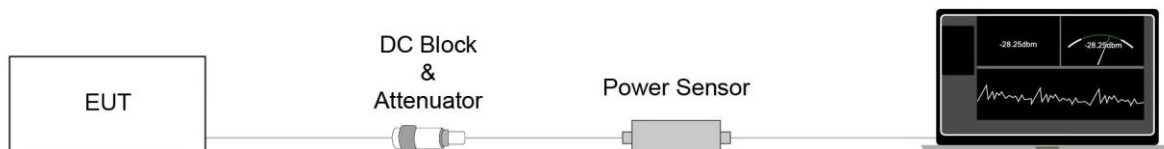

6.4.5. Test Result

Refer to Appendix A.4.

6.5. Power Spectral Density Measurement

6.5.1. Test Limit

For the band 5.725-5.85 GHz, the maximum power spectral density shall not exceed 30 dBm in any 500-kHz band.

If transmitting antennas of directional gain greater than 6dBi are used, the peak power spectral density shall be reduced by the amount in dB that the directional gain of the antenna exceeds 6dBi.

6.5.2. Test Procedure

KDB 789033 D02v02r01-Section II)F)

6.5.3. Test Setting

1. Analyzer was set to the center frequency of the UNII channel under investigation
2. Span was set to encompass the entire 26dB EBW of the signal.
3. RBW = 1MHz (510kHz, if measurement bandwidth of Maximum PSD is specified in 500 kHz)
4. VBW = 3 × RBW
5. Number of sweep points $\geq 2 \times (\text{span} / \text{RBW})$
6. Detector = power averaging (Average)
7. Sweep time = auto
8. Trigger = free run
9. Trace average at least 100 traces in power averaging (rms) mode; however, the number of traces to be averaged shall be increased above 100 as needed to ensure that the average accurately represents the true average over the on and off periods of the transmitter.
10. Use the peak search function on the instrument to find the peak of the spectrum and record its value.
11. Add $10 \cdot \log(1/x)$, where x is the duty cycle, to the measured power in order to compute the average power during the actual transmission times (because the measurement represents an average over both the on and off times of the transmission). For example, add $10 \cdot \log(1/0.25) = 6$ dB if the duty cycle is 25 percent.

6.5.4. Test Setup

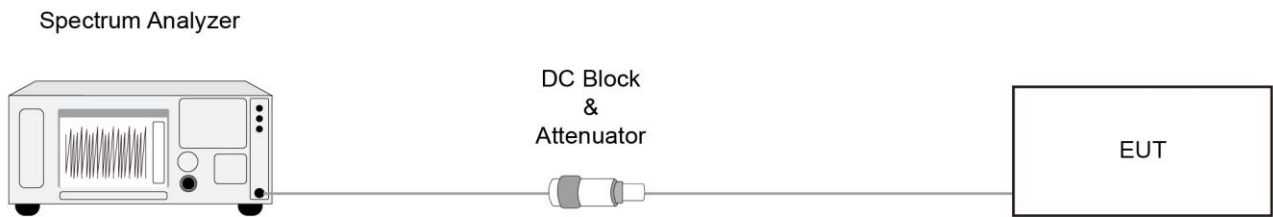

6.5.5. Test Result

Refer to Appendix A.5.

6.6. Frequency Stability Measurement

6.6.1. Test Limit

Manufactures of U-NII devices are responsible for ensuring frequency stability such that an emission is maintained within the band of operation under all conditions of normal operation as specified in the user's manual.

6.6.2. Test Procedure

Frequency Stability Under Temperature Variations:

The equipment under test was connected to an external AC or DC power supply and input rated voltage. RF output was connected to a frequency counter or spectrum analyzer via feed through attenuators. The EUT was placed inside the temperature chamber. Set the spectrum analyzer RBW low enough to obtain the desired frequency resolution and measure EUT 20°C operating frequency as reference frequency. Turn EUT off and set the chamber temperature to highest. After the temperature stabilized for approximately 30 minutes recorded the frequency. Repeat step measure with 10°C decreased per stage until the lowest temperature reached.

Frequency Stability Under Voltage Variations:

Set chamber temperature to 20°C. Use a variable AC power supply / DC power source to power the EUT and set the voltage to rated voltage. Set the spectrum analyzer RBW low enough to obtain the desired frequency resolution and recorded the frequency.

Reduce the input voltage to specify extreme voltage variation ($\pm 15\%$) and endpoint, record the maximum frequency change.

6.6.3. Test Setup

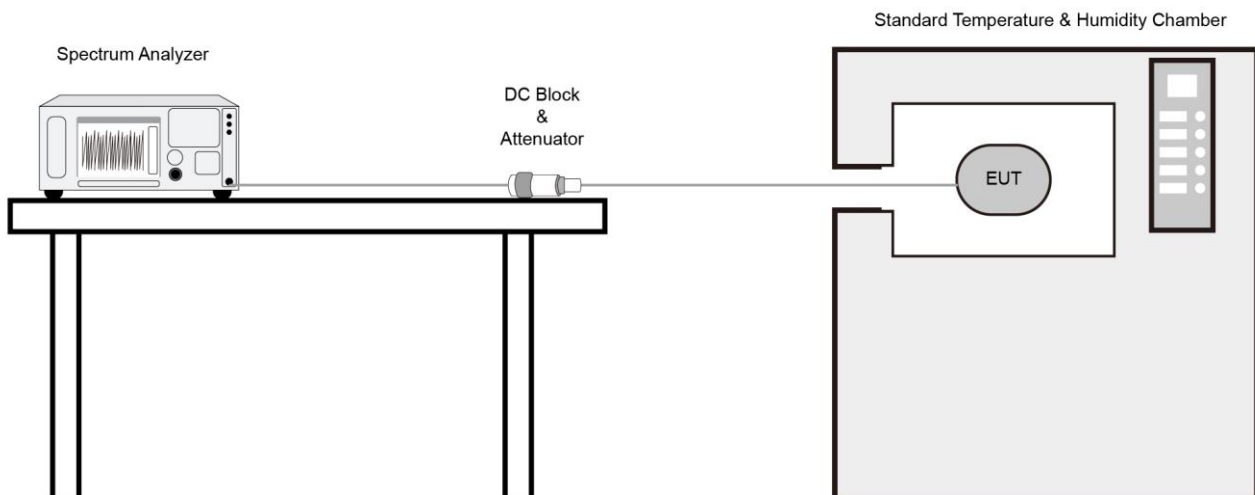

6.6.4. Test Result

Refer to Appendix A.6.

6.7. Radiated Spurious Emission Measurement

6.7.1. Test Limit

All out of band emissions appearing in a restricted band as specified in Section 15.205 of the Title 47 CFR must not exceed the limits shown in Table per Section 15.209.

FCC Part 15 Subpart C Paragraph 15.209		
Frequency [MHz]	Field Strength [$\mu\text{V/m}$]	Measured Distance [Meters]
0.009 - 0.490	2400/F (kHz)	300
0.490 - 1.705	24000/F (kHz)	30
1.705 - 30	30	30
30 - 88	100	3
88 - 216	150	3
216 - 960	200	3
Above 960	500	3

6.7.2. Test Procedure

KDB 789033 D02v02r01- Section II)G)

6.7.3. Test Setting

Table 1 - RBW as a function of frequency

Frequency	RBW
9 ~ 150 kHz	200 ~ 300 Hz
0.15 ~ 30 MHz	9 ~ 10 kHz
30 ~ 1000 MHz	100 ~ 120 kHz
> 1000MHz	1MHz

Quasi-Peak Measurements below 1GHz

1. Analyzer center frequency was set to the frequency of the radiated spurious emission of interest
2. Span was set greater than 1MHz
3. RBW = as specified in Table 1
4. Detector = CISPR quasi-peak
5. Sweep time = auto couple
6. Trace was allowed to stabilize

Peak Measurements above 1GHz

1. Analyzer center frequency was set to the frequency of the radiated spurious emission of interest
2. RBW = 1MHz
3. VBW = 3MHz
4. Detector = peak
5. Sweep time = auto couple
6. Trace mode = max hold
7. Trace was allowed to stabilize

Average Measurements above 1GHz (Method VB)

1. Analyzer center frequency was set to the frequency of the radiated spurious emission of interest
2. RBW = 1MHz
3. VBW; If the EUT is configured to transmit with duty cycle $\geq 98\%$, set VBW = 10 Hz.
If the EUT duty cycle is $< 98\%$, set VBW $\geq 1/T$. T is the minimum transmission duration.
4. Detector = Peak
5. Sweep time = auto
6. Trace mode = max hold
7. Trace was allowed to stabilize

6.7.4. Test Setup

Below 30MHz Test Setup:

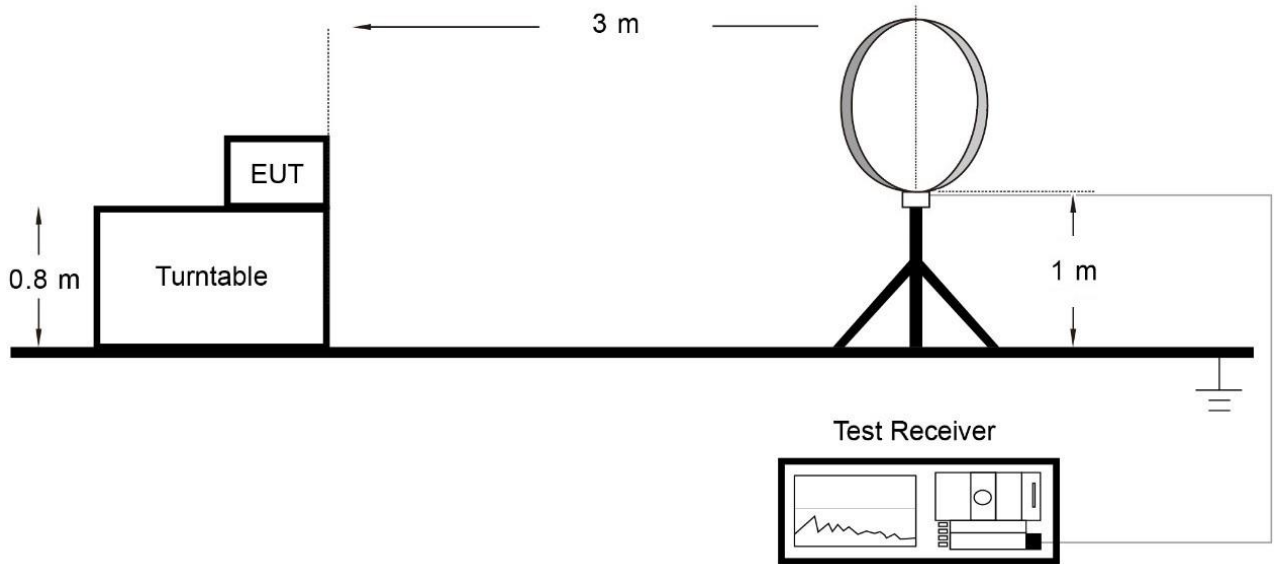

Below 1GHz Test Setup:

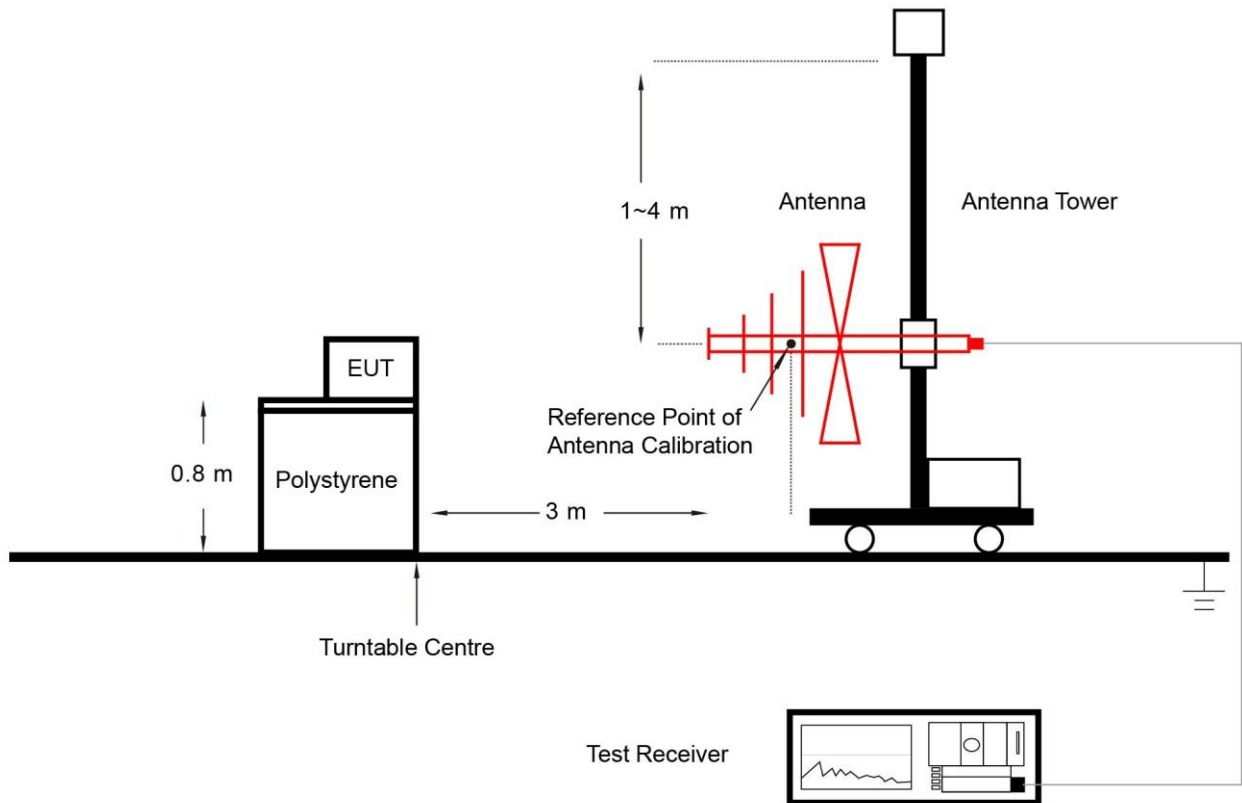

Above 1GHz Test Setup:

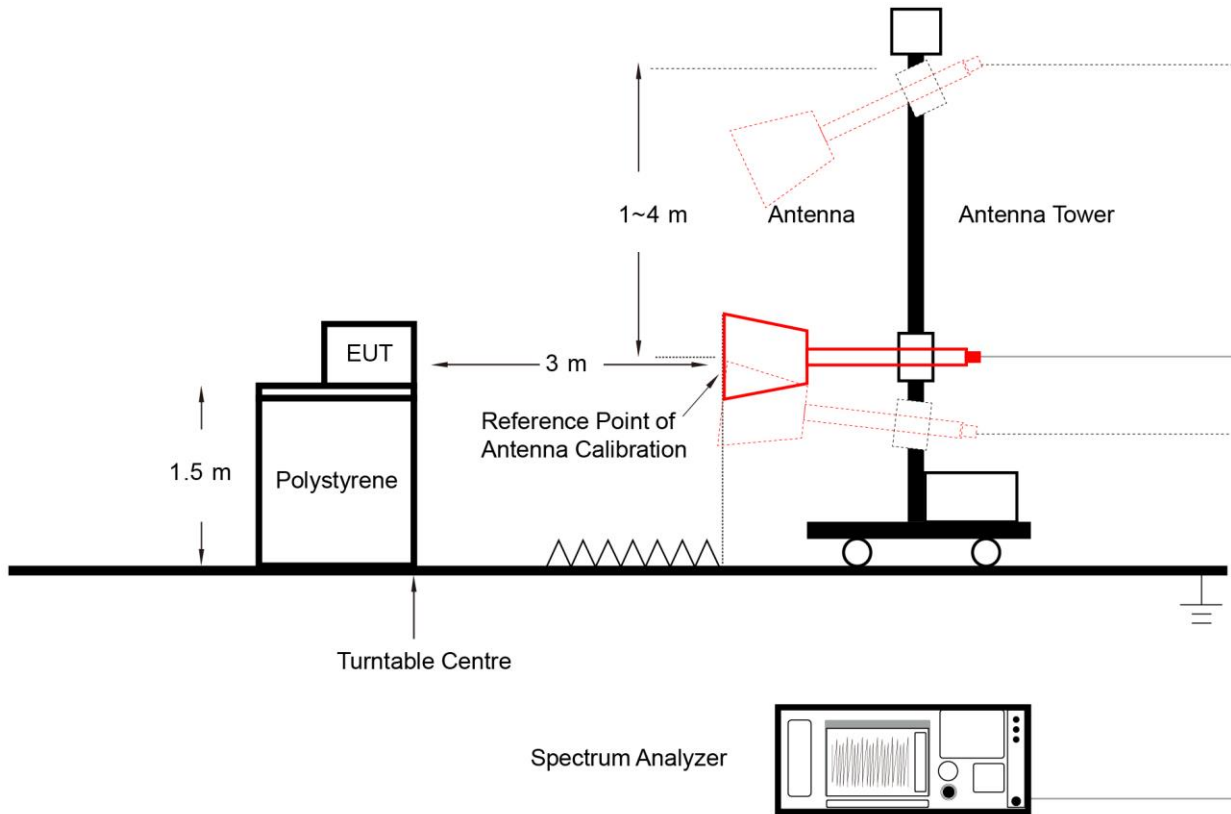

6.7.5. Test Result

Refer to Appendix A.7.

6.8. Radiated Restricted Band Edge Measurement

6.8.1. Test Limit

For 15.205 requirement:

Radiated emissions which fall in the restricted bands, as defined in Section 15.205(a) of FCC part 15, must also comply with the radiated emission limits specified in Section 15.209(a).

Frequency (MHz)	Frequency (MHz)	Frequency (MHz)	Frequency (GHz)
0.090 - 0.110	16.42 - 16.423	399.9 - 410	4.5 - 5.15
¹ 0.495 - 0.505	16.69475 - 16.69525	608 - 614	5.35 - 5.46
2.1735 - 2.1905	16.80425 - 16.80475	960 - 1240	7.25 - 7.75
4.125 - 4.128	25.5 - 25.67	1300 - 1427	8.025 - 8.5
4.17725 - 4.17775	37.5 - 38.25	1435 - 1626.5	9.0 - 9.2
4.20725 - 4.20775	73 - 74.6	1645.5 - 1646.5	9.3 - 9.5
6.215 - 6.218	74.8 - 75.2	1660 - 1710	10.6 - 12.7
6.26775 - 6.26825	108 - 121.94	1718.8 - 1722.2	13.25 - 13.4
6.31175 - 6.31225	123 - 138	2200 - 2300	14.47 - 14.5
8.291 - 8.294	149.9 - 150.05	2310 - 2390	15.35 - 16.2
8.362 - 8.366	156.52475 - 156.52525	2483.5 - 2500	17.7 - 21.4
8.37625 - 8.38675	156.7 - 156.9	2690 - 2900	22.01 - 23.12
8.41425 - 8.41475	162.0125 - 167.17	3260 - 3267	23.6 - 24.0
12.29 - 12.293	167.72 - 173.2	3332 - 3339	31.2 - 31.8
12.51975 - 12.52025	240 - 285	3345.8 - 3358	36.43 - 36.5
12.57675 - 12.57725	322 - 335.4	3600 - 4400	(²)
13.36 - 13.41	--	--	--

For 15.407(b) requirement:

For transmitters operating in the 5.725-5.85 GHz band: All emissions shall be limited to a level of -27 dBm/MHz at 75 MHz or more above or below the band edge increasing linearly to 10 dBm/MHz at 25 MHz above or below the band edge, and from 25 MHz above or below the band edge increasing linearly to a level of 15.6 dBm/MHz at 5 MHz above or below the band edge, and from 5 MHz above or below the band edge increasing linearly to a level of 27 dBm/MHz at the band edge.

Refer to KDB 789033 D02v02r01 G)2)c), as specified in § 15.407(b), emissions above 1000 MHz that are outside of the restricted bands are subject to a maximum emission limit of -27 dBm/MHz (or -17 dBm/MHz as specified in § 15.407(b)(4)). However, an out-of-band emission that complies with both the peak and average limits of § 15.209 is not required to satisfy the -27 dBm/MHz or -17 dBm/MHz maximum emission limit.

All out of band emissions appearing in a restricted band as specified in Section 15.205 of the Title 47CFR must not exceed the limits shown in Table per Section 15.209.

FCC Part 15 Subpart C Paragraph 15.209		
Frequency [MHz]	Field Strength [μ V/m]	Measured Distance [Meters]
0.009 - 0.490	2400/F (kHz)	300
0.490 - 1.705	24000/F (kHz)	30
1.705 - 30	30	30
30 - 88	100	3
88 - 216	150	3
216 - 960	200	3
Above 960	500	3

6.8.2. Test Procedure

KDB 789033 D02v02r01- Section II)G)

6.8.3. Test Setting

Peak Measurements above 1GHz

1. Analyzer center frequency was set to the frequency of the radiated spurious emission of interest
2. RBW = 1MHz
3. VBW = 3MHz
4. Detector = Peak
5. Sweep time = Auto couple
6. Trace mode = Max hold
7. Trace was allowed to stabilize

Average Measurements above 1GHz (Method VB)

1. Analyzer center frequency was set to the frequency of the radiated spurious emission of interest
2. RBW = 1MHz
3. VBW; if the EUT is configured to transmit with duty cycle $\geq 98\%$, set VBW = 10Hz
4. If the EUT duty cycle is $< 98\%$, set VBW $\geq 1/T$. T is the minimum transmission duration
5. Detector = Peak
6. Sweep time = Auto
7. Trace mode = Max hold
8. Trace was allowed to stabilize

6.8.4. Test Setup

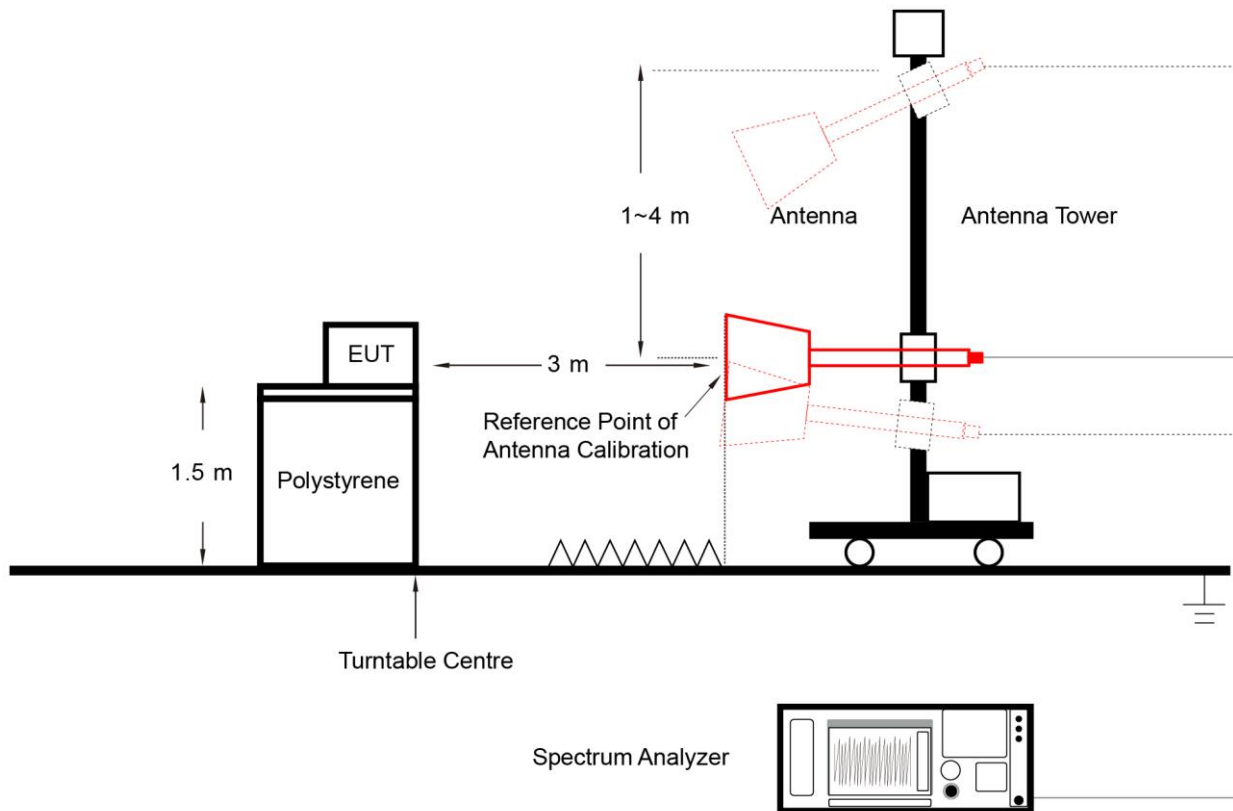

6.8.5. Test Result

Refer to Appendix A.8.

6.9. AC Conducted Emissions Measurement

6.9.1. Test Limit

FCC Part 15.207 Limits		
Frequency (MHz)	QP (dB μ V)	AV (dB μ V)
0.15 - 0.50	66 - 56	56 - 46
0.50 - 5.0	56	46
5.0 - 30	60	50

Note 1: The lower limit shall apply at the transition frequencies.

Note 2: The limit decreases linearly with the logarithm of the frequency in the range 0.15MHz to 0.5MHz.

6.9.2. Test Setup

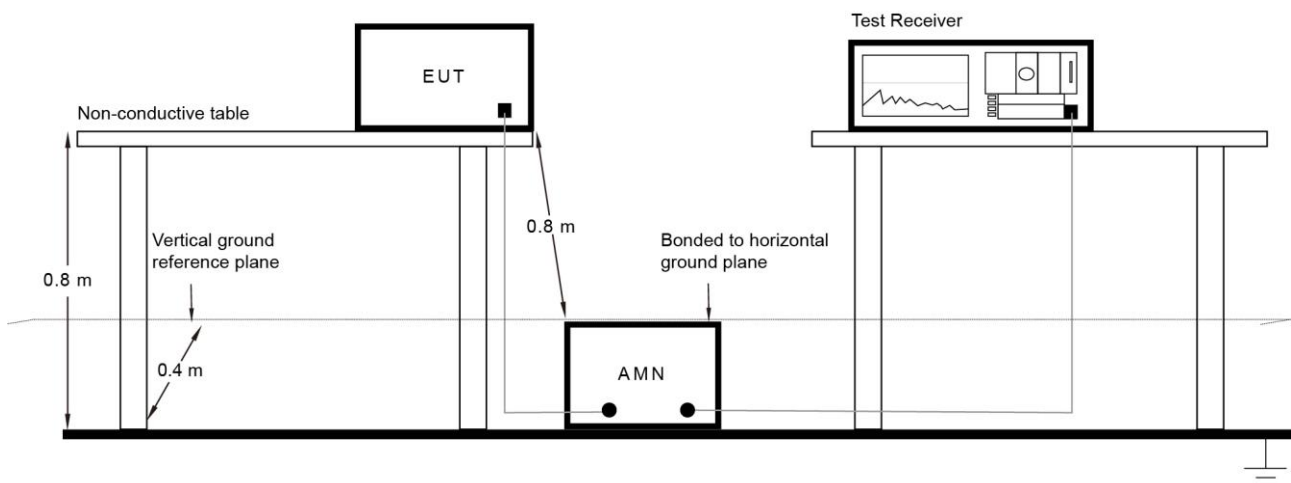

6.9.3. Test Result

The device is powered by battery in actual use, so this test item is not applicable.

Appendix A – Test Result

A.1 Duty Cycle Test Result

Test Site	WZ-SR4	Test Engineer	Jeff Yang
Test Date	2023-10-20		

Duty Cycle	92.01%
------------	--------

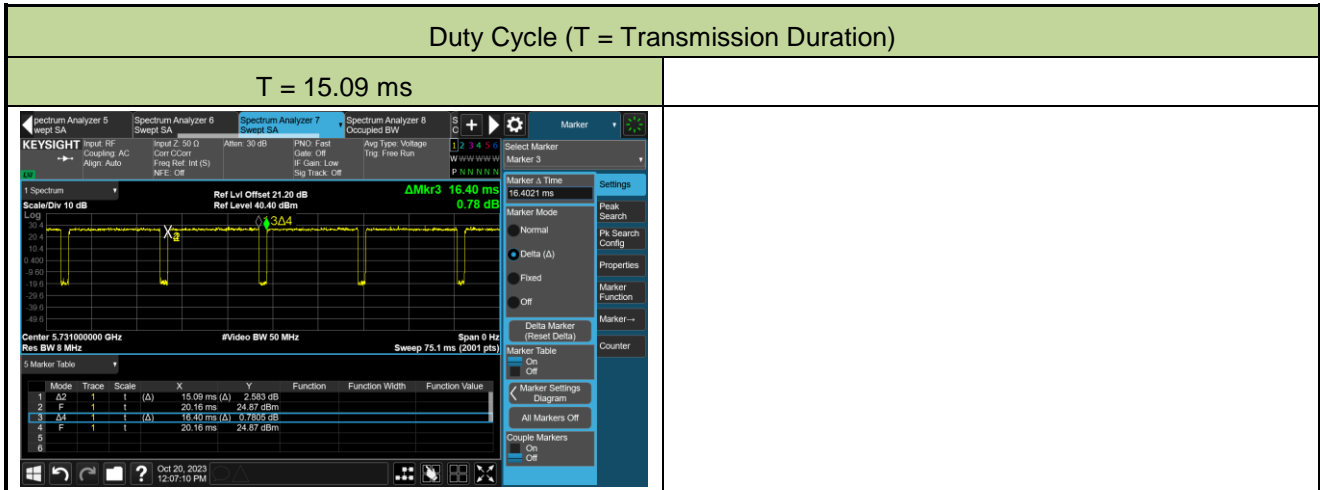

A.2 26dB Bandwidth Test Result

Test Site	WZ-SR4	Test Engineer	Jeff Yang
Test Date	2023-10-20		

Frequency (MHz)	26dB Bandwidth (MHz)	99% Bandwidth (MHz)
SISO Mode - Ant 0		
5731	9.569	8.9990
5765	12.37	9.0402
5782	12.02	9.0451
SISO Mode - Ant 1		
5731	11.36	9.0431
5765	12.97	9.0192
5782	12.55	9.0824

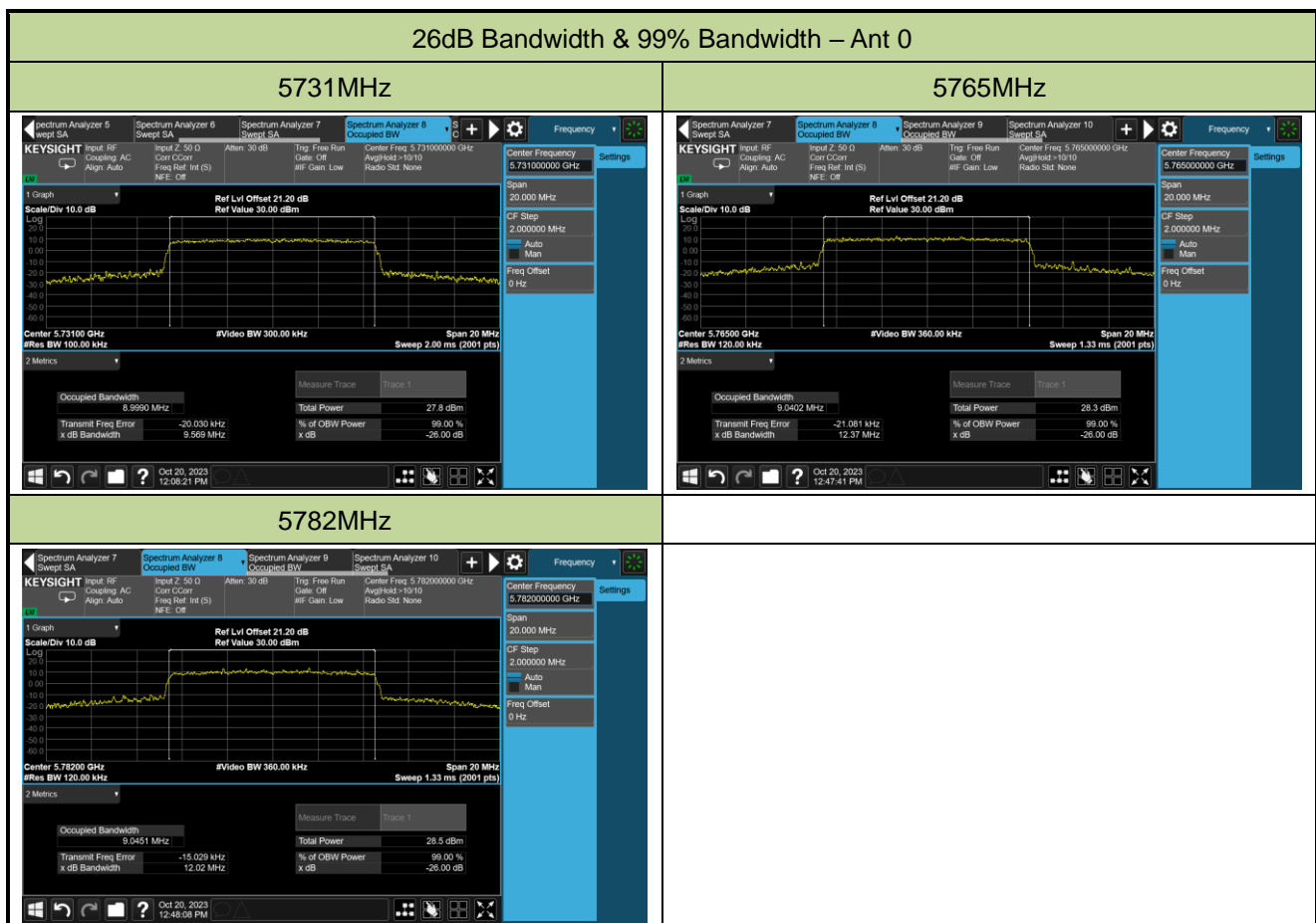

26dB Bandwidth & 99% Bandwidth – Ant 1

5731MHz

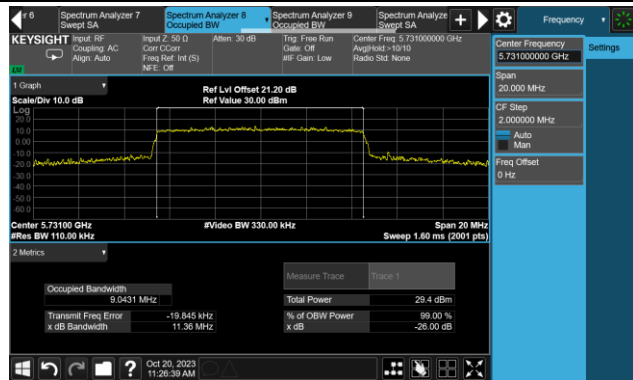

5765MHz

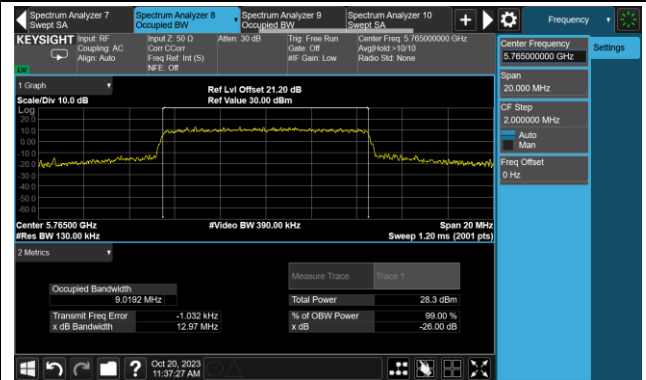

5782MHz

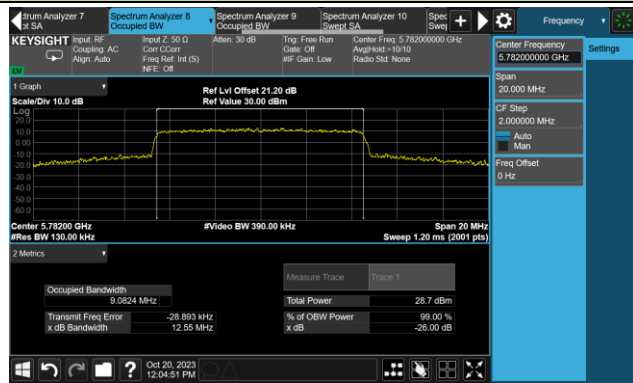

A.3 6dB Bandwidth Test Result

Test Site	WZ-SR4	Test Engineer	Jeff Yang
Test Date	2023-10-20		

Frequency (MHz)	6dB Bandwidth (MHz)	Limit (MHz)
SISO Mode - Ant 0		
5731	9.019	≥0.5
5765	8.987	≥0.5
5782	8.861	≥0.5
SISO Mode - Ant 1		
5731	9.018	≥0.5
5765	9.039	≥0.5
5782	8.951	≥0.5

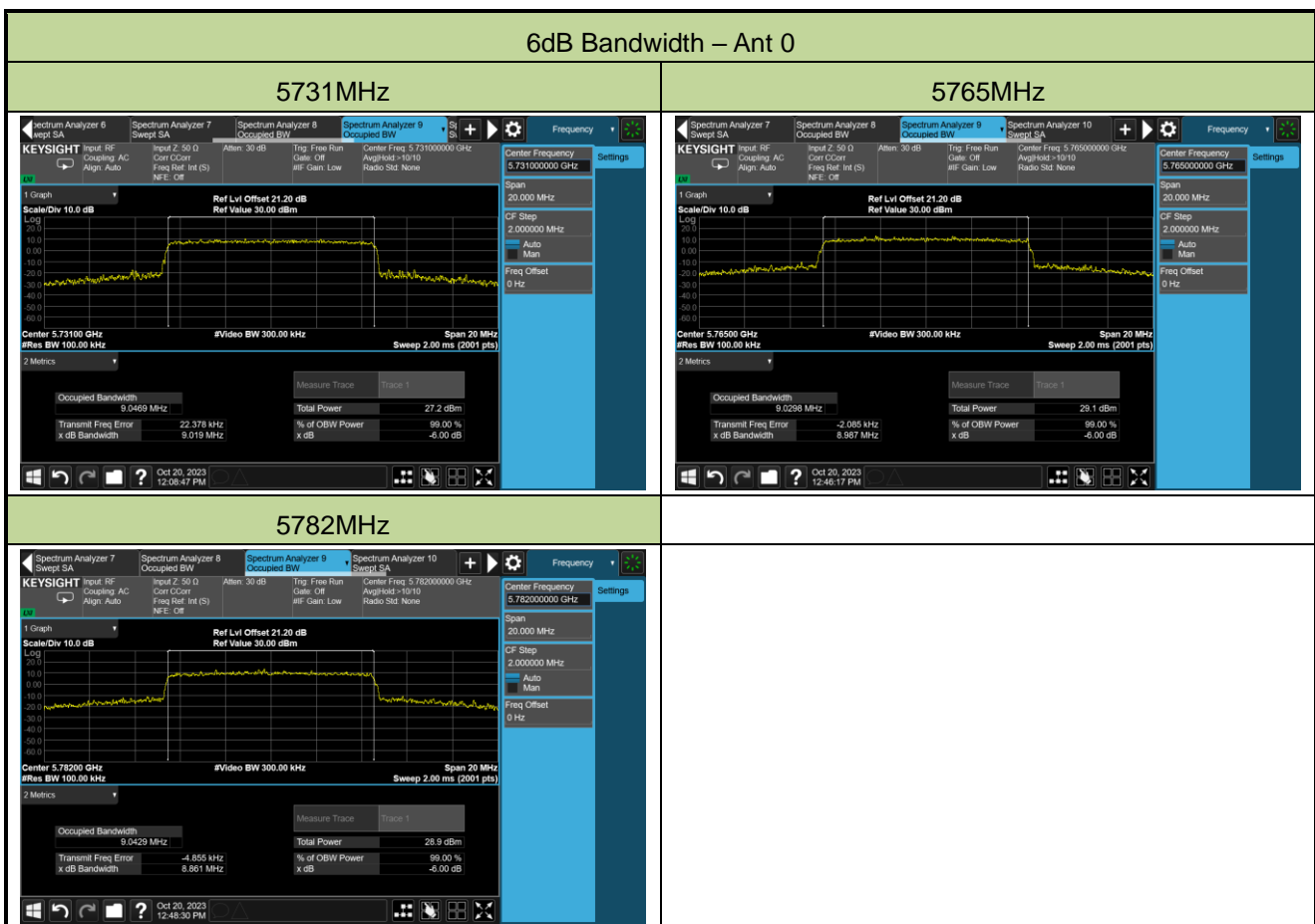

6dB Bandwidth – Ant 1

5731MHz

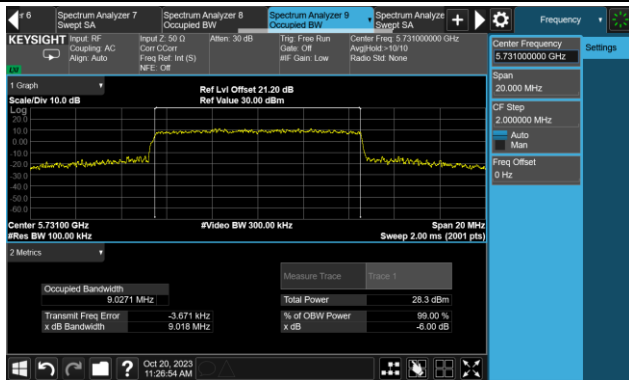

5765MHz

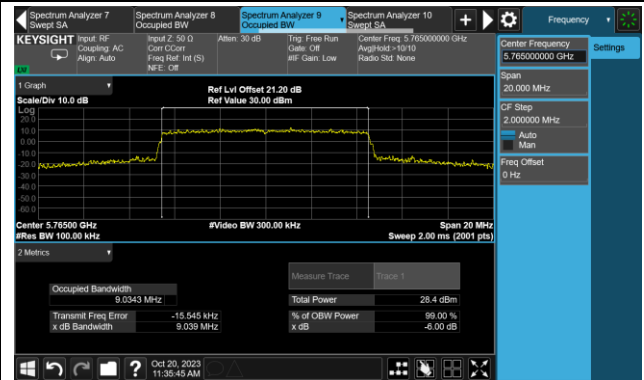

5782MHz

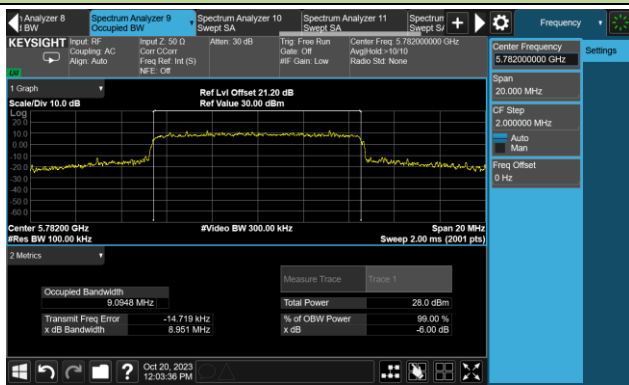

A.4 Output Power Test Result

Test Site	WZ-SR4	Test Engineer	Jeff Yang
Test Date	2023-09-01		

Freq. (MHz)	Average Power (dBm)		Power Limit (dBm)
	Ant 0	Ant 1	
5731	23.57	23.66	≤ 30.00
5765	23.88	23.52	≤ 30.00
5782	23.92	23.97	≤ 30.00

A.5 Power Spectral Density Test Result

Test Site	WZ-SR4	Test Engineer	Jeff Yang
Test Date	2023-10-20		

Freq. (MHz)	AV PSD (dBm/510kHz)		Duty Cycle (%)	10*log(1/x)	Total PSD (dBm/510kHz)		PSD Limit (dBm/500kHz)
	Ant 0	Ant 1			Ant 0	Ant 1	
5731	7.64	7.99	92.01	0.362	8.00	8.35	≤ 30.00
5765	8.64	7.69	92.01	0.362	9.00	8.05	≤ 30.00
5782	8.69	7.81	92.01	0.362	9.05	8.17	≤ 30.00

Note: When Duty Cycle < 98%, Total PSD (dBm/510kHz) = AV PSD (dBm/510kHz) + 10*log (1/Duty Cycle).

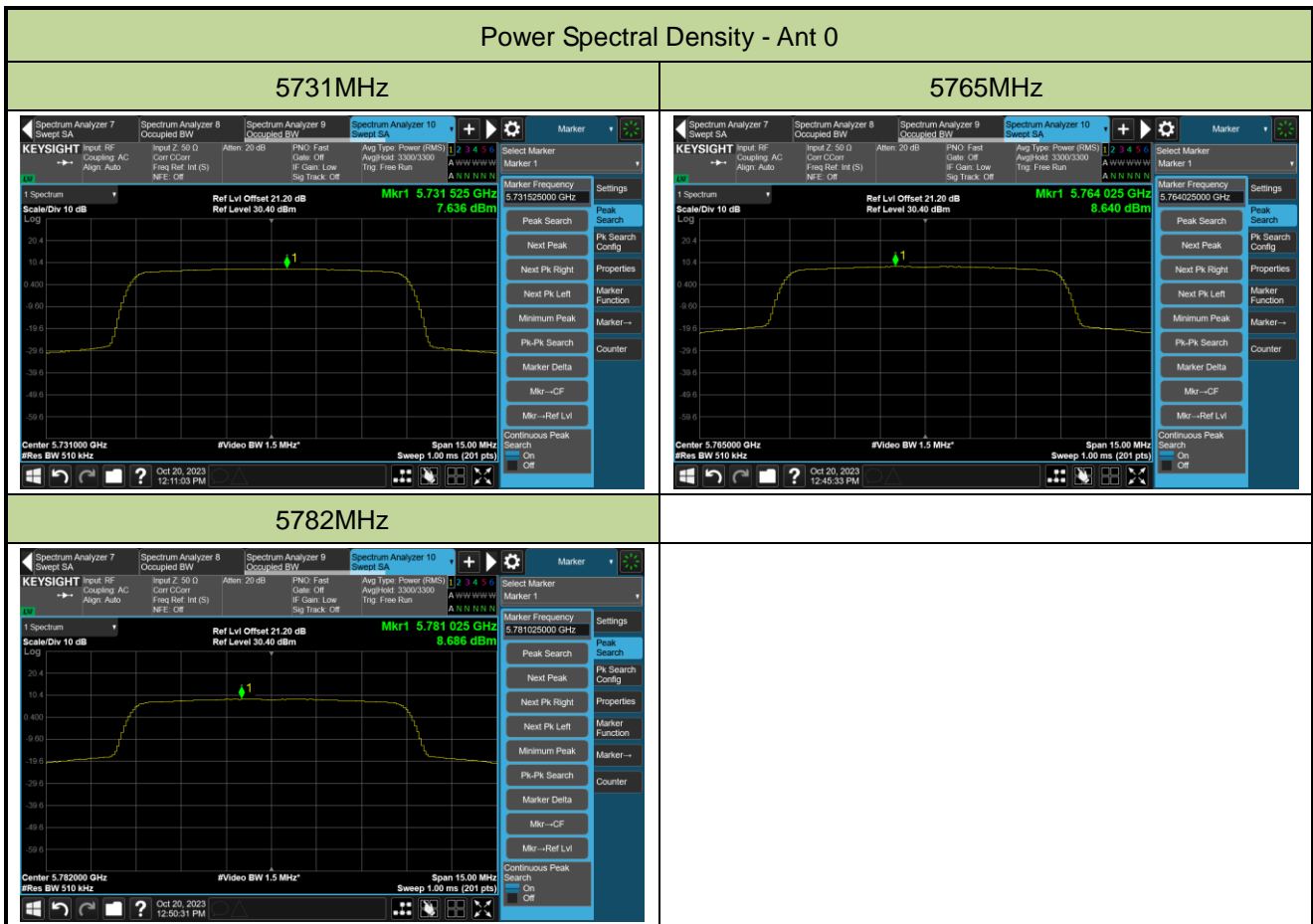

Power Spectral Density - Ant 1

5731MHz

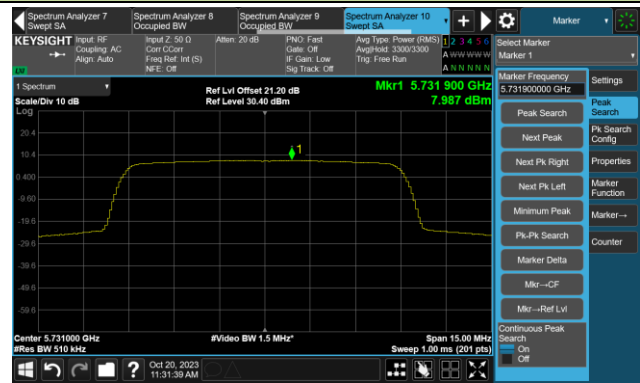

5765MHz

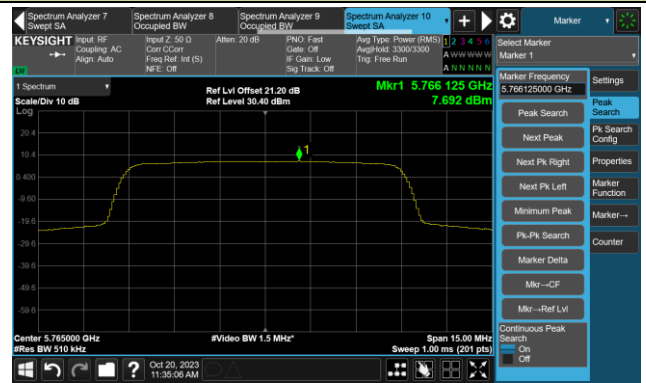

5782MHz



A.6 Frequency Stability Test Result

Test Site	WZ-TR3	Test Engineer	Jeff Yang
Test Date	2023-10-20	Test Mode	5731MHz (Carrier Mode) - Ant 0

Voltage (%)	Power (VDC)	Temp (°C)	Frequency Tolerance (ppm)			
			0 minutes	2 minutes	5 minutes	10 minutes
100%	24.0	- 30	-2.16	-2.18	-2.20	-2.21
		- 20	-2.16	-2.16	-2.16	-2.16
		- 10	-2.20	-2.20	-2.20	-2.20
		0	-2.19	-2.20	-2.20	-2.20
		+ 10	-2.18	-2.18	-2.18	-2.18
		+ 20	-2.26	-2.23	-2.22	-2.21
		+ 30	-2.32	-2.32	-2.32	-2.32
		+ 40	-2.29	-2.28	-2.28	-2.28
		+ 50	-2.40	-2.28	-2.42	-2.40
115%	27.6	+ 20	-2.25	-2.23	-2.20	-2.21
85%	20.4	+ 20	-2.25	-2.22	-2.22	-2.23

Note: Frequency Tolerance (ppm) = $\{[\text{Measured Frequency (Hz)} - \text{Declared Frequency (Hz)}] / \text{Declared Frequency (Hz)}\} * 10^6$.

Test Site	WZ-TR3	Test Engineer	Jeff Yang
Test Date	2023-10-20	Test Mode	5731MHz (Carrier Mode) - Ant 1

Voltage (%)	Power (VDC)	Temp (°C)	Frequency Tolerance (ppm)			
			0 minutes	2 minutes	5 minutes	10 minutes
100%	24.0	- 30	-2.18	-2.18	-2.21	-2.21
		- 20	-2.17	-2.17	-2.16	-2.16
		- 10	-2.21	-2.20	-2.20	-2.18
		0	-2.20	-2.22	-2.21	-2.20
		+ 10	-2.17	-2.18	-2.16	-2.18
		+ 20	-2.25	-2.22	-2.22	-2.24
		+ 30	-2.32	-2.32	-2.32	-2.32
		+ 40	-2.29	-2.28	-2.27	-2.29
		+ 50	-2.30	-2.26	-2.43	-2.25
115%	27.6	+ 20	-2.24	-2.23	-2.23	-2.22
85%	20.4	+ 20	-2.24	-2.22	-2.22	-2.21

Note: Frequency Tolerance (ppm) = $\{[\text{Measured Frequency (Hz)} - \text{Declared Frequency (Hz)}] / \text{Declared Frequency (Hz)}\} * 10^6$.

A.7 Radiated Spurious Emission Test Result

Test Site	WZ-AC1	Test Engineer	Carl Jiang
Test Date	2023-09-03	Test Mode	5731MHz – SISO Mode Ant 0
Remark	1. Average measurement was not performed if peak level lower than average limit. 2. Other frequency was 20dB below limit line within 1-18GHz, there is not show in the report.		

Mark	Frequency (MHz)	Reading Level (dBμV)	Factor (dB/m)	Measure Level (dBμV/m)	Limit (dBμV/m)	Margin (dB)	Detector	Polarization
*	9755.0	35.7	12.9	48.6	68.2	-19.6	Peak	Horizontal
	11616.5	36.6	13.1	49.7	74.0	-24.3	Peak	Horizontal
	12067.0	36.4	12.4	48.8	74.0	-25.2	Peak	Horizontal
*	17192.5	46.6	15.3	61.9	68.2	-6.3	Peak	Horizontal
*	10027.0	33.8	12.9	46.7	68.2	-21.5	Peak	Vertical
	10987.5	33.5	14.3	47.8	74.0	-26.2	Peak	Vertical
	11463.5	42.1	13.5	55.6	74.0	-18.4	Peak	Vertical
	11463.5	30.9	13.5	44.4	54.0	-9.6	Average	Vertical
	17192.5	51.4	15.3	66.7	68.2	-1.5	Peak	Vertical

Note 1: "*" is not in restricted band, its limit is -27dBm/MHz. At a distance of 3 meters, the field strength limit in dBμV/m can be determined by adding a "conversion" factor of 95.2dB to the EIRP limit of -27dBm/MHz to obtain the limit for out of band spurious emissions.

Note 2: Measure Level (dBμV/m) = Reading Level (dBμV) + Factor (dB/m)

Factor (dB/m) = Cable Loss (dB) + Antenna Factor (dB/m) - Pre_Amplifier Gain (dB)

Test Site	WZ-AC1	Test Engineer	Carl Jiang
Test Date	2023-10-21	Test Mode	5765MHz – SISO Mode Ant 0
Remark	1. Average measurement was not performed if peak level lower than average limit. 2. Other frequency was 20dB below limit line within 1-18GHz, there is not show in the report.		

Mark	Frequency (MHz)	Reading Level (dBμV)	Factor (dB/m)	Measure Level (dBμV/m)	Limit (dBμV/m)	Margin (dB/m)	Detector	Polarization
*	10120.5	33.6	13.1	46.7	68.2	-21.5	Peak	Horizontal
	11038.5	34.8	14.1	48.9	74.0	-25.1	Peak	Horizontal
	12050.0	35.1	12.5	47.6	74.0	-26.4	Peak	Horizontal
*	17303.0	46.3	16.2	62.5	68.2	-5.7	Peak	Horizontal
*	9899.5	33.4	13.0	46.4	68.2	-21.8	Peak	Vertical
	11531.5	43.9	13.5	57.4	74.0	-16.6	Peak	Vertical
	11531.5	31.0	13.5	44.5	54.0	-9.5	Average	Vertical
	12186.0	35.1	12.2	47.3	74.0	-26.7	Peak	Vertical
	17294.5	51.6	16.1	67.7	68.2	-0.5	Peak	Vertical

Note 1: "*" is not in restricted band, its limit is -27dBm/MHz. At a distance of 3 meters, the field strength limit in dBμV/m can be determined by adding a "conversion" factor of 95.2dB to the EIRP limit of -27dBm/MHz to obtain the limit for out of band spurious emissions.

Note 2: Measure Level (dBμV/m) = Reading Level (dBμV) + Factor (dB/m)

Factor (dB/m) = Cable Loss (dB) + Antenna Factor (dB/m) - Pre_Amplifier Gain (dB)

Test Site	WZ-AC1	Test Engineer	Carl Jiang
Test Date	2023-10-21	Test Mode	5782MHz – SISO Mode Ant 0
Remark	1. Average measurement was not performed if peak level lower than average limit. 2. Other frequency was 20dB below limit line within 1-18GHz, there is not show in the report.		

Mark	Frequency (MHz)	Reading Level (dBμV)	Factor (dB/m)	Measure Level (dBμV/m)	Limit (dBμV/m)	Margin (dB/m)	Detector	Polarization
*	9704.0	35.9	12.8	48.7	68.2	-19.5	Peak	Horizontal
	11038.5	35.0	14.1	49.1	74.0	-24.9	Peak	Horizontal
	12033.0	35.0	12.5	47.5	74.0	-26.5	Peak	Horizontal
*	17345.5	46.3	16.3	62.6	68.2	-5.6	Peak	Horizontal
*	10248.0	33.7	13.4	47.1	68.2	-21.1	Peak	Vertical
	10996.0	34.1	14.4	48.5	74.0	-25.5	Peak	Vertical
	11565.5	43.6	13.3	56.9	74.0	-17.1	Peak	Vertical
	11565.5	30.1	13.3	43.4	54.0	-10.6	Average	Vertical
	17345.5	49.5	16.3	65.8	68.2	-2.4	Peak	Vertical

Note 1: "*" is not in restricted band, its limit is -27dBm/MHz. At a distance of 3 meters, the field strength limit in dBμV/m can be determined by adding a "conversion" factor of 95.2dB to the EIRP limit of -27dBm/MHz to obtain the limit for out of band spurious emissions.

Note 2: Measure Level (dBμV/m) = Reading Level (dBμV) + Factor (dB/m)

Factor (dB/m) = Cable Loss (dB) + Antenna Factor (dB/m) - Pre_Amplifier Gain (dB)

Test Site	WZ-AC1	Test Engineer	Carl Jiang
Test Date	2023-10-21	Test Mode	5731MHz – SISO Mode Ant 1
Remark	1. Average measurement was not performed if peak level lower than average limit. 2. Other frequency was 20dB below limit line within 1-18GHz, there is not show in the report.		

Mark	Frequency (MHz)	Reading Level (dB μ V)	Factor (dB/m)	Measure Level (dB μ V/m)	Limit (dB μ V/m)	Margin (dB)	Detector	Polarization
*	9993.0	33.5	13.0	46.5	68.2	-21.7	Peak	Horizontal
	10783.5	34.3	14.1	48.4	74.0	-25.6	Peak	Horizontal
	11676.0	36.9	12.9	49.8	74.0	-24.2	Peak	Horizontal
*	17192.5	43.9	15.3	59.2	68.2	-9.0	Peak	Horizontal
*	10171.5	33.8	13.3	47.1	68.2	-21.1	Peak	Vertical
	11463.5	46.8	13.5	60.3	74.0	-13.7	Peak	Vertical
	11463.5	34.0	13.5	47.5	54.0	-6.5	Average	Vertical
	12041.5	35.7	12.5	48.2	74.0	-25.8	Peak	Vertical
*	17192.5	48.5	15.3	63.8	68.2	-4.4	Peak	Vertical

Note 1: "*" is not in restricted band, its limit is -27dBm/MHz. At a distance of 3 meters, the field strength limit in dB μ V/m can be determined by adding a "conversion" factor of 95.2dB to the EIRP limit of -27dBm/MHz to obtain the limit for out of band spurious emissions.

Note 2: Measure Level (dB μ V/m) = Reading Level (dB μ V) + Factor (dB/m)

Factor (dB/m) = Cable Loss (dB) + Antenna Factor (dB/m) - Pre_Amplifier Gain (dB)

Test Site	WZ-AC1	Test Engineer	Carl Jiang
Test Date	2023-10-21	Test Mode	5765MHz – SISO Mode Ant 1
Remark	1. Average measurement was not performed if peak level lower than average limit. 2. Other frequency was 20dB below limit line within 1-18GHz, there is not show in the report.		

Mark	Frequency (MHz)	Reading Level (dB μ V)	Factor (dB/m)	Measure Level (dB μ V/m)	Limit (dB μ V/m)	Margin (dB/m)	Detector	Polarization
*	10214.0	32.5	13.2	45.7	68.2	-22.5	Peak	Horizontal
	11480.5	34.9	13.6	48.5	74.0	-25.5	Peak	Horizontal
	12109.5	34.3	12.4	46.7	74.0	-27.3	Peak	Horizontal
*	17294.5	46.4	16.1	62.5	68.2	-5.7	Peak	Horizontal
*	9780.5	34.4	13.0	47.4	68.2	-20.8	Peak	Vertical
	11531.5	45.2	13.5	58.7	74.0	-15.3	Peak	Vertical
	11531.5	34.8	13.5	48.3	54.0	-5.7	Average	Vertical
	11948.0	34.4	12.3	46.7	74.0	-27.3	Peak	Vertical
	17294.5	51.0	16.1	67.1	68.2	-1.1	Peak	Vertical

Note 1: "*" is not in restricted band, its limit is -27dBm/MHz. At a distance of 3 meters, the field strength limit in dB μ V/m can be determined by adding a "conversion" factor of 95.2dB to the EIRP limit of -27dBm/MHz to obtain the limit for out of band spurious emissions.

Note 2: Measure Level (dB μ V/m) = Reading Level (dB μ V) + Factor (dB/m)

Factor (dB/m) = Cable Loss (dB) + Antenna Factor (dB/m) - Pre_Amplifier Gain (dB)

Test Site	WZ-AC1	Test Engineer	Carl Jiang
Test Date	2023-10-21	Test Mode	5782MHz – SISO Mode Ant 1
Remark	1. Average measurement was not performed if peak level lower than average limit. 2. Other frequency was 20dB below limit line within 1-18GHz, there is not show in the report.		

Mark	Frequency (MHz)	Reading Level (dB μ V)	Factor (dB/m)	Measure Level (dB μ V/m)	Limit (dB μ V/m)	Margin (dB/m)	Detector	Polarization
	10962.0	34.3	14.1	48.4	74.0	-25.6	Peak	Horizontal
	11565.5	34.9	13.3	48.2	74.0	-25.8	Peak	Horizontal
*	14260.0	34.8	15.7	50.5	68.2	-17.7	Peak	Horizontal
*	17345.5	46.6	16.3	62.9	68.2	-5.3	Peak	Horizontal
*	10273.5	34.5	13.5	48.0	68.2	-20.2	Peak	Vertical
	11565.5	44.0	13.3	57.3	74.0	-16.7	Peak	Vertical
	11565.5	33.9	13.3	47.2	54.0	-6.8	Average	Vertical
	12058.5	34.9	12.5	47.4	74.0	-26.6	Peak	Vertical
	17345.5	50.3	16.3	66.6	68.2	-1.6	Peak	Vertical

Note 1: "*" is not in restricted band, its limit is -27dBm/MHz. At a distance of 3 meters, the field strength limit in dB μ V/m can be determined by adding a "conversion" factor of 95.2dB to the EIRP limit of -27dBm/MHz to obtain the limit for out of band spurious emissions.

Note 2: Measure Level (dB μ V/m) = Reading Level (dB μ V) + Factor (dB/m)

Factor (dB/m) = Cable Loss (dB) + Antenna Factor (dB/m) - Pre_Amplifier Gain (dB)

The Result of Radiated Emission for 30MHz ~ 1GHz:

Site: WZ-AC2	Test Date: 2023-10-13
Limit: FCC_Part15.209_RSE(3m)	Engineer: Karl Gao
Probe: VULB9162_30-7000MHz	Polarity: Horizontal
EUT: S1 RC	Power: AC 120V/60Hz
Test Mode: Transmit at 5782MHz with Ant 1	

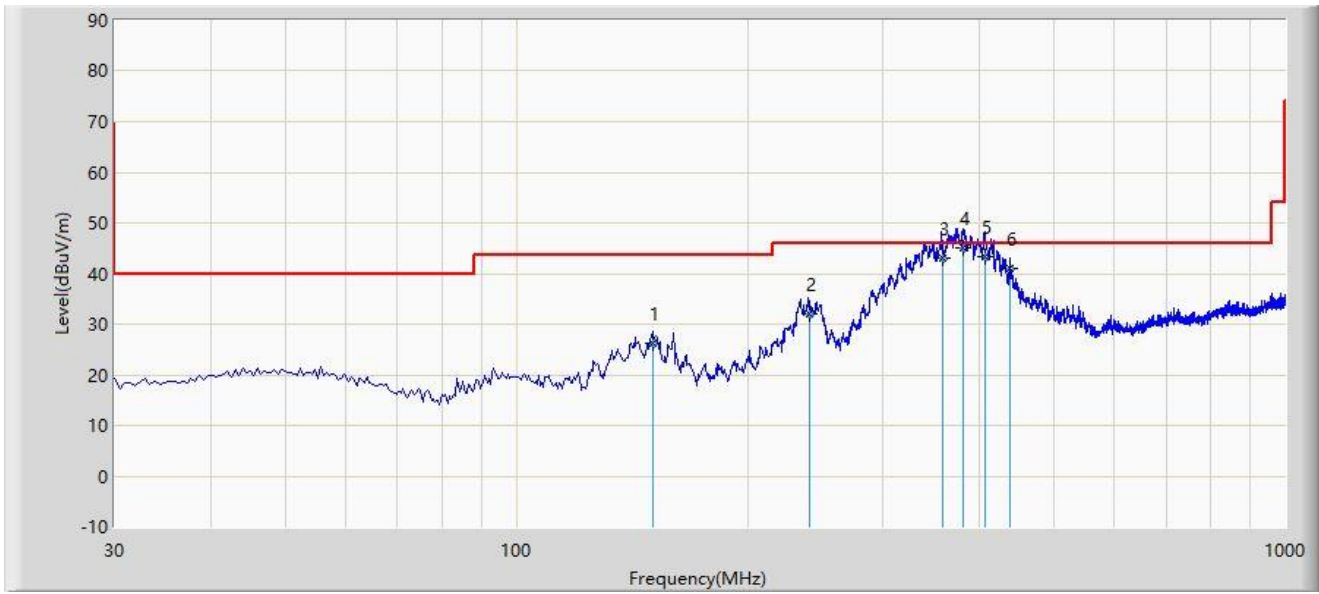

No	Mark	Frequency (MHz)	Measure Level (dB μ V/m)	Reading Level (dB μ V)	Margin (dB)	Limit (dB μ V/m)	Factor (dB/m)	Type
1		150.300	26.293	11.100	-17.207	43.500	15.193	QP
2		240.200	32.005	12.300	-13.995	46.000	19.705	QP
3		357.800	43.037	20.800	-2.963	46.000	22.237	QP
4	*	382.010	45.093	22.100	-0.907	46.000	22.993	QP
5		406.900	43.349	19.600	-2.651	46.000	23.749	QP
6		439.200	41.078	17.100	-4.922	46.000	23.978	QP

Note 1: " * ", means this data is the worst emission level.

Note 2: Measure Level (dB μ V/m) = Reading Level (dB μ V) + Factor (dB/m).

Note 3: Factor (dB/m) = Cable Loss (dB) + Antenna Factor (dB/m).

Note 4: The amplitude of radiated emissions (frequency range from 9kHz to 30MHz and 18GHz to 40GHz) is that proximity to ambient noise, which also are attenuated more than 20 dB below the permissible value.

Therefore, the data is not presented in the report.

Site: WZ-AC2	Test Date: 2023-10-13
Limit: FCC_Part15.209_RSE(3m)	Engineer: Karl Gao
Probe: VULB9162_30-7000MHz	Polarity: Vertical
EUT: S1 RC	Power: AC 120V/60Hz
Test Mode: Transmit at 5782MHz with Ant 1	

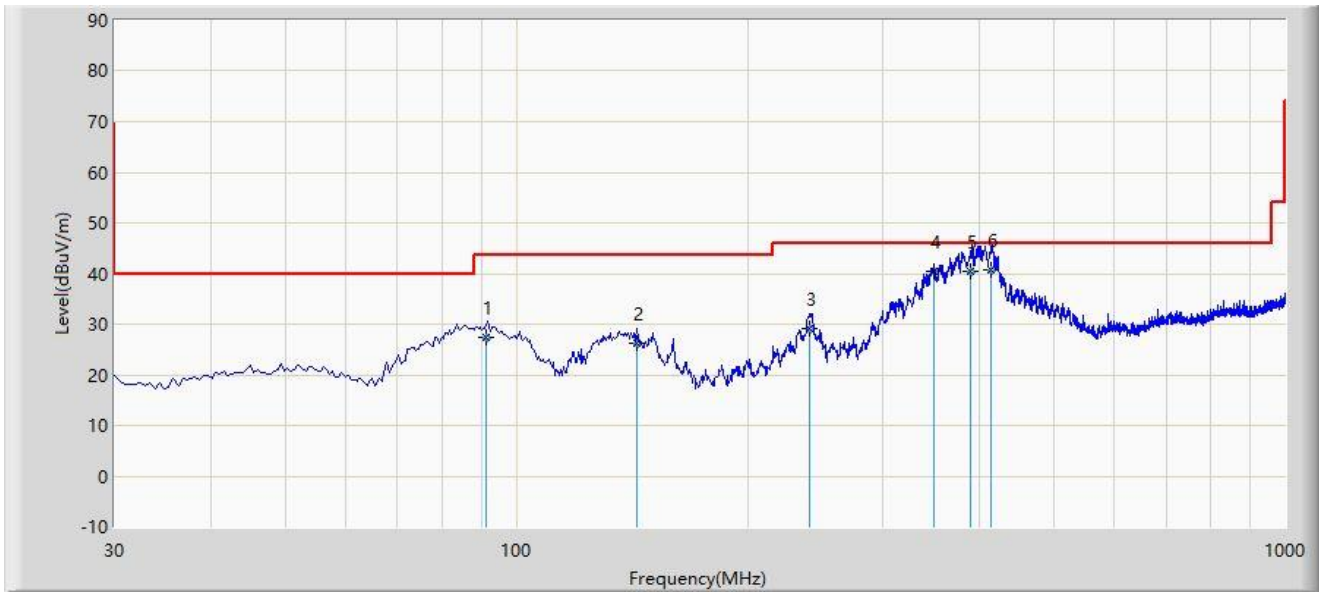

No	Mark	Frequency (MHz)	Measure Level (dB μ V/m)	Reading Level (dB μ V)	Margin (dB)	Limit (dB μ V/m)	Factor (dB/m)	Type
1		91.360	27.397	10.600	-16.103	43.500	16.796	QP
2		143.600	26.217	11.200	-17.283	43.500	15.017	QP
3		240.900	29.018	9.300	-16.982	46.000	19.717	QP
4		348.600	40.396	17.600	-5.604	46.000	22.795	QP
5		390.500	40.464	17.200	-5.536	46.000	23.265	QP
6	*	414.300	40.726	16.900	-5.274	46.000	23.826	QP

Note 1: " * ", means this data is the worst emission level.

Note 2: Measure Level (dB μ V/m) = Reading Level (dB μ V) + Factor (dB/m).

Note 3: Factor (dB/m) = Cable Loss (dB) + Antenna Factor (dB/m).

Note 4: The amplitude of radiated emissions (frequency range from 9kHz to 30MHz and 18GHz to 40GHz) is that proximity to ambient noise, which also are attenuated more than 20 dB below the permissible value.

Therefore, the data is not presented in the report.

A.8 Radiated Restricted Band Edge Test Result

Site: WZ-AC1	Test Date: 2023-09-03
Limit: FCC_5.8G_RE(3m)	Engineer: Carl Jiang
Probe: BBHA9120D_1167_1-18GHz	Polarity: Horizontal
EUT: S1 RC	Power: AC 120V/60Hz
Test Mode: Transmit at 5731MHz Ant 0	

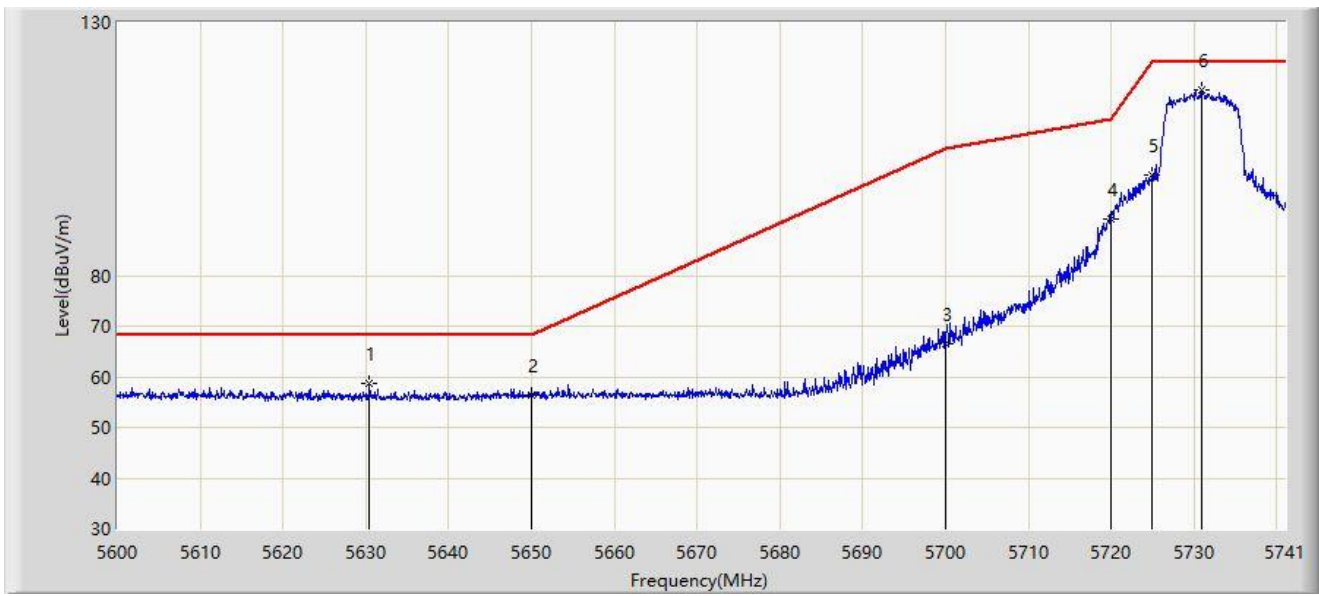

No	Mark	Frequency (MHz)	Measure Level (dB μ V/m)	Reading Level (dB μ V)	Margin (dB)	Limit (dB μ V/m)	Factor (dB/m)	Type
1	*	5630.456	58.745	54.846	-9.455	68.200	3.899	PK
2		5650.000	56.446	52.312	-11.754	68.200	4.134	PK
3		5700.000	66.438	62.264	-38.762	105.200	4.173	PK
4		5720.000	91.145	86.928	-19.655	110.800	4.217	PK
5		5725.000	99.791	95.560	-22.409	122.200	4.231	PK
6		5730.848	116.742	112.468	N/A	N/A	4.274	PK

Note 1: " * ", means this data is the worst emission level.

Note 2: Measure Level (dB μ V/m) = Reading Level (dB μ V) + Factor (dB/m).

Note 3: Factor (dB/m) = Cable Loss (dB) + Antenna Factor (dB/m) - Pre_Amplifier Gain (dB).

Site: WZ-AC1	Test Date: 2023-09-03
Limit: FCC_5.8G_RE(3m)	Engineer: Carl Jiang
Probe: BBHA9120D_1167_1-18GHz	Polarity: Vertical
EUT: S1 RC	Power: AC 120V/60Hz
Test Mode: Transmit at 5731MHz Ant 0	

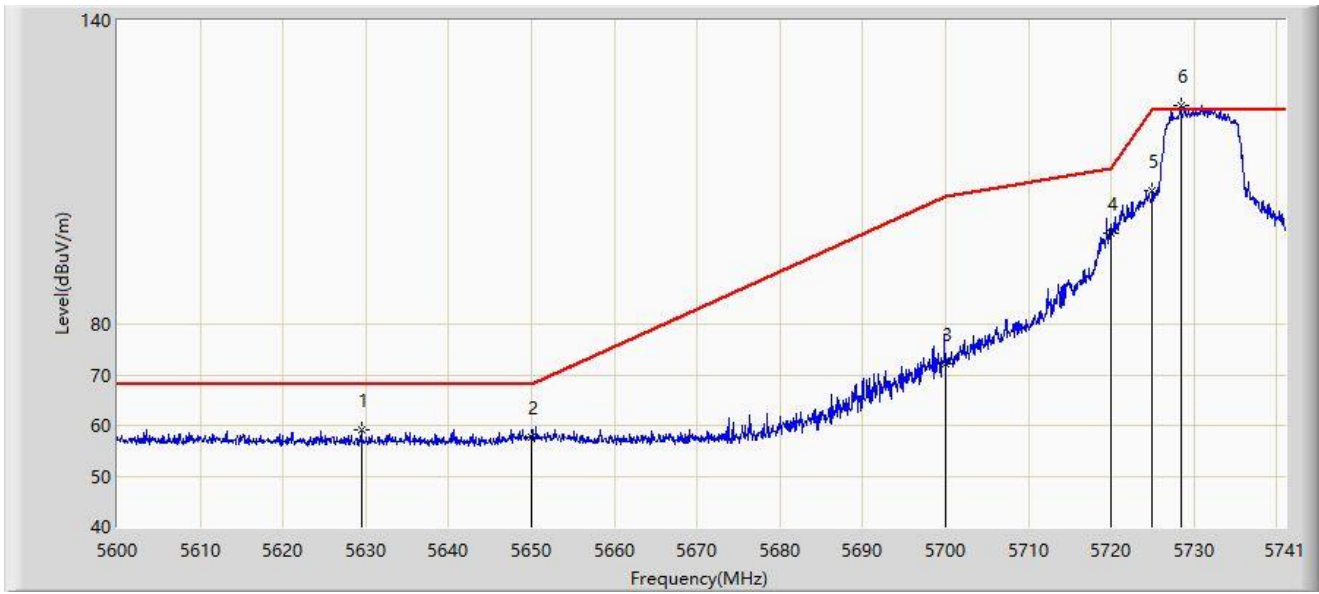

No	Mark	Frequency (MHz)	Measure Level (dB μ V/m)	Reading Level (dB μ V)	Margin (dB)	Limit (dB μ V/m)	Factor (dB/m)	Type
1	*	5629.469	59.263	55.362	-8.937	68.200	3.901	PK
2		5650.000	57.709	53.575	-10.491	68.200	4.134	PK
3		5700.000	72.066	67.892	-33.134	105.200	4.173	PK
4		5720.000	97.859	93.642	-12.941	110.800	4.217	PK
5		5725.000	106.298	102.067	-15.902	122.200	4.231	PK
6		5728.451	123.073	118.822	N/A	N/A	4.250	PK

Note 1: " * ", means this data is the worst emission level.

Note 2: Measure Level (dB μ V/m) = Reading Level (dB μ V) + Factor (dB/m).

Note 3: Factor (dB/m) = Cable Loss (dB) + Antenna Factor (dB/m) - Pre_Amplifier Gain (dB).

Site: WZ-AC1	Test Date: 2023-09-03
Limit: FCC_5.8G_RE(3m)	Engineer: Carl Jiang
Probe: BBHA9120D_1167_1-18GHz	Polarity: Horizontal
EUT: S1 RC	Power: AC 120V/60Hz
Test Mode: Transmit at 5782MHz Ant 0	

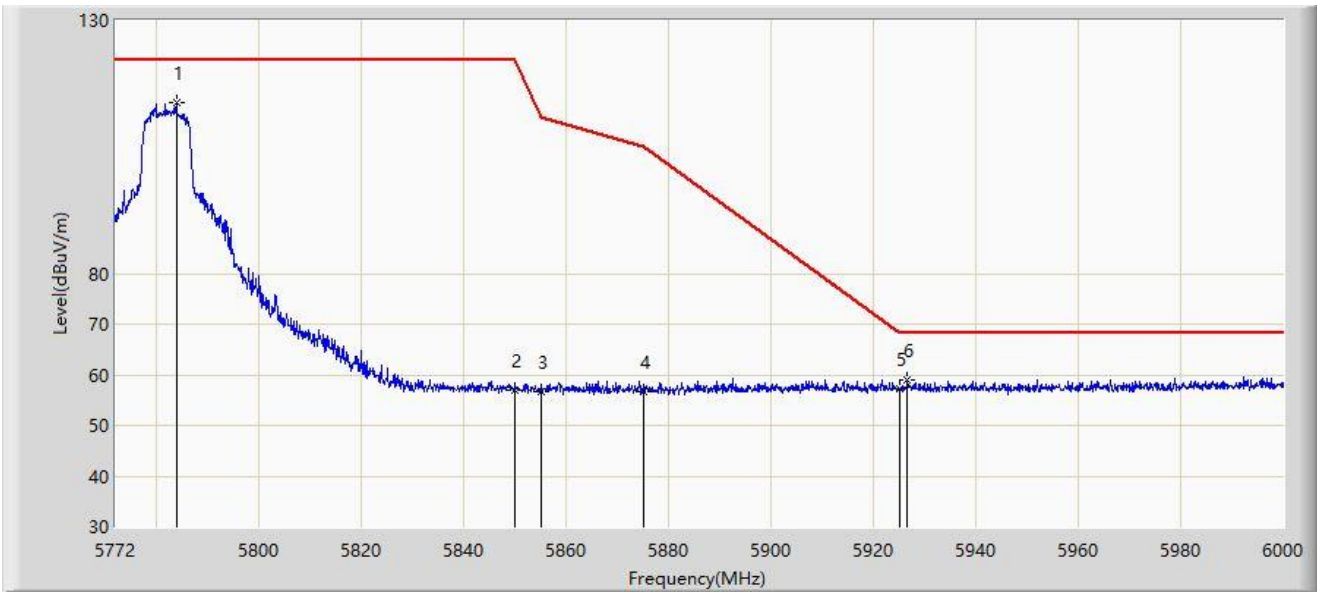

No	Mark	Frequency (MHz)	Measure Level (dB μ V/m)	Reading Level (dB μ V)	Margin (dB)	Limit (dB μ V/m)	Factor (dB/m)	Type
1		5783.970	113.903	109.573	N/A	N/A	4.331	PK
2		5850.000	56.980	52.380	-65.220	122.200	4.599	PK
3		5855.000	56.577	52.017	-54.223	110.800	4.560	PK
4		5875.000	56.643	52.180	-48.557	105.200	4.462	PK
5		5925.000	57.128	52.497	-11.072	68.200	4.631	PK
6	*	5926.698	58.942	54.309	-9.258	68.200	4.633	PK

Note 1: " * ", means this data is the worst emission level.

Note 2: Measure Level (dB μ V/m) = Reading Level (dB μ V) + Factor (dB/m).

Note 3: Factor (dB/m) = Cable Loss (dB) + Antenna Factor (dB/m) - Pre_Amplifier Gain (dB).

Site: WZ-AC1	Test Date: 2023-09-03
Limit: FCC_5.8G_RE(3m)	Engineer: Carl Jiang
Probe: BBHA9120D_1167_1-18GHz	Polarity: Vertical
EUT: S1 RC	Power: AC 120V/60Hz
Test Mode: Transmit at 5782MHz Ant 0	

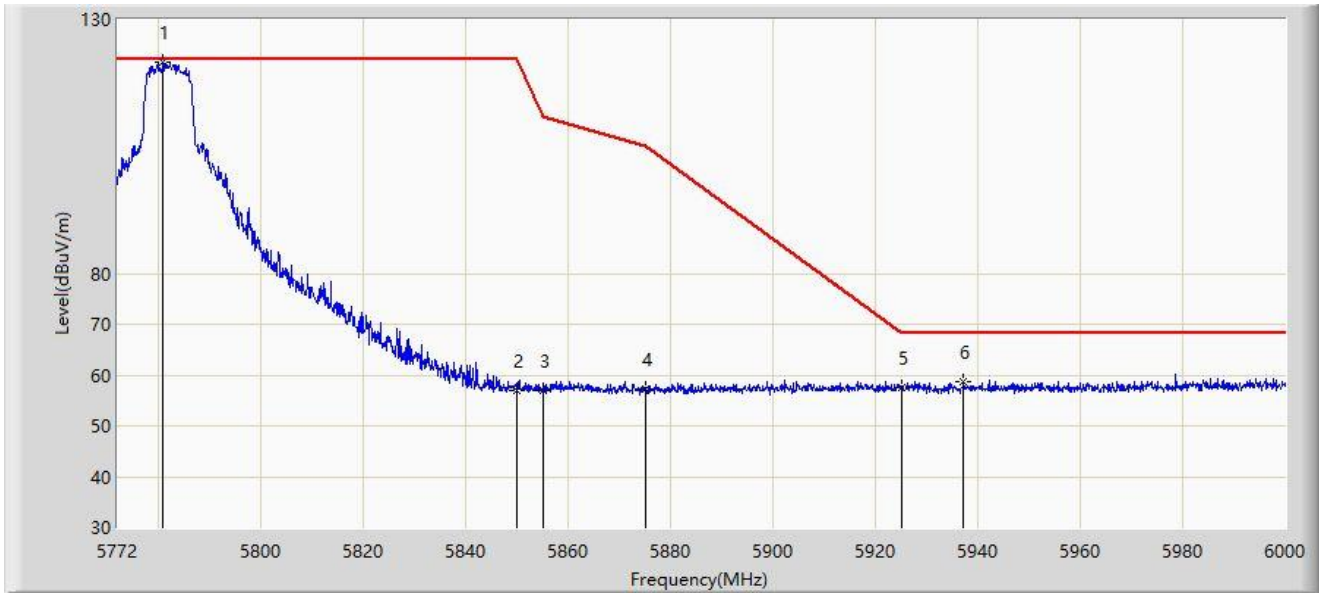

No	Mark	Frequency (MHz)	Measure Level (dBμV/m)	Reading Level (dBμV)	Margin (dB)	Limit (dBμV/m)	Factor (dB/m)	Type
1		5780.892	121.462	117.140	N/A	N/A	4.322	PK
2		5850.000	57.074	52.474	-65.126	122.200	4.599	PK
3		5855.000	56.906	52.346	-53.894	110.800	4.560	PK
4		5875.000	57.163	52.700	-48.037	105.200	4.462	PK
5		5925.000	57.400	52.769	-10.800	68.200	4.631	PK
6	*	5937.186	58.557	54.005	-9.643	68.200	4.552	PK

Note 1: " * ", means this data is the worst emission level.

Note 2: Measure Level (dBμV/m) = Reading Level (dBμV) + Factor (dB/m).

Note 3: Factor (dB/m) = Cable Loss (dB) + Antenna Factor (dB/m) - Pre_Amplifier Gain (dB).

Site: WZ-AC1	Test Date: 2023-09-03
Limit: FCC_5.8G_RE(3m)	Engineer: Carl Jiang
Probe: BBHA9120D_1167_1-18GHz	Polarity: Horizontal
EUT: S1 RC	Power: AC 120V/60Hz
Test Mode: Transmit at 5731MHz Ant 1	

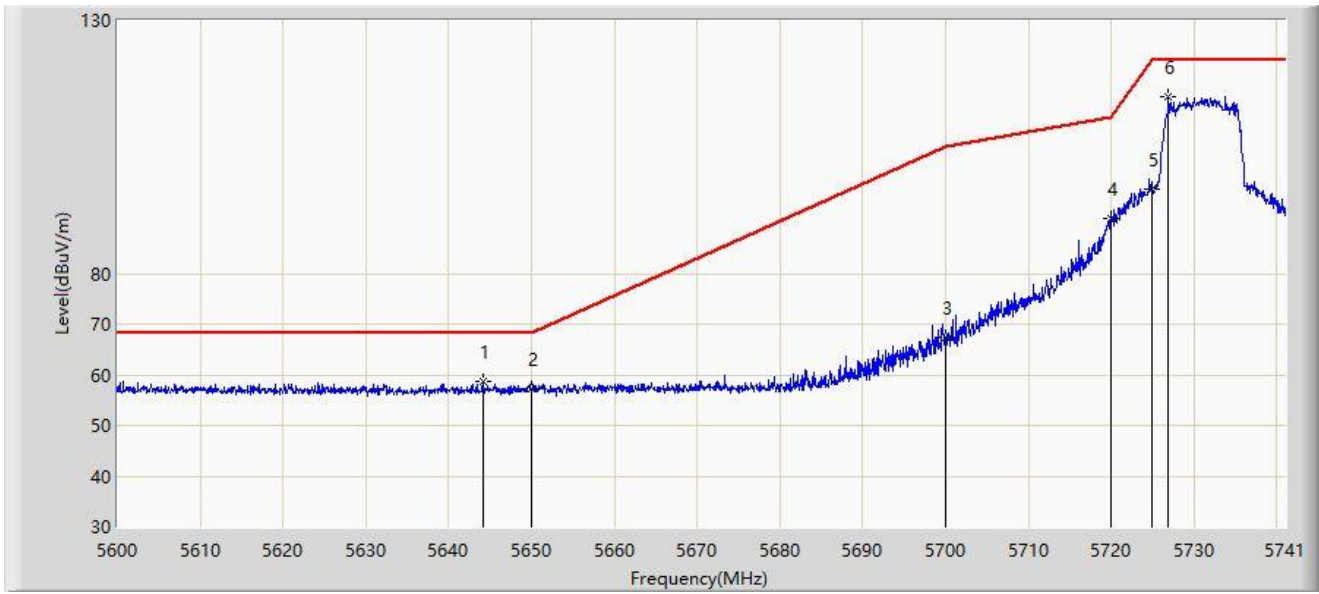

No	Mark	Frequency (MHz)	Measure Level (dB μ V/m)	Reading Level (dB μ V)	Margin (dB)	Limit (dB μ V/m)	Factor (dB/m)	Type
1	*	5644.133	58.559	54.571	-9.641	68.200	3.988	PK
2		5650.000	57.221	53.087	-10.979	68.200	4.134	PK
3		5700.000	67.336	63.162	-37.864	105.200	4.173	PK
4		5720.000	90.822	86.605	-19.978	110.800	4.217	PK
5		5725.000	96.798	92.567	-25.402	122.200	4.231	PK
6		5726.900	114.790	110.554	N/A	N/A	4.235	PK

Note 1: " * ", means this data is the worst emission level.

Note 2: Measure Level (dB μ V/m) = Reading Level (dB μ V) + Factor (dB/m).

Note 3: Factor (dB/m) = Cable Loss (dB) + Antenna Factor (dB/m) - Pre_Amplifier Gain (dB).

Site: WZ-AC1	Test Date: 2023-09-03
Limit: FCC_5.8G_RE(3m)	Engineer: Carl Jiang
Probe: BBHA9120D_1167_1-18GHz	Polarity: Vertical
EUT: S1 RC	Power: AC 120V/60Hz
Test Mode: Transmit at 5731MHz Ant 1	

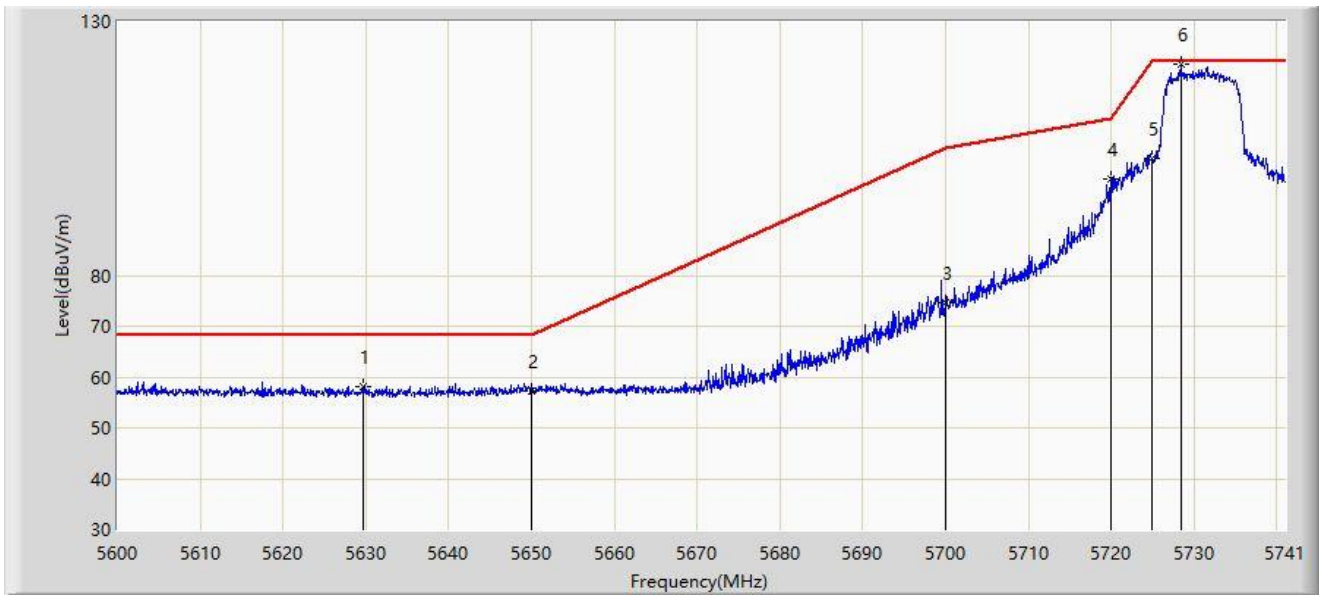

No	Mark	Frequency (MHz)	Measure Level (dB μ V/m)	Reading Level (dB μ V)	Margin (dB)	Limit (dB μ V/m)	Factor (dB/m)	Type
1	*	5629.610	58.193	54.292	-10.007	68.200	3.901	PK
2		5650.000	57.287	53.153	-10.913	68.200	4.134	PK
3		5700.000	74.518	70.344	-30.682	105.200	4.173	PK
4		5720.000	99.012	94.795	-11.788	110.800	4.217	PK
5		5725.000	103.138	98.907	-19.062	122.200	4.231	PK
6		5728.380	121.581	117.331	N/A	N/A	4.249	PK

Note 1: " * ", means this data is the worst emission level.

Note 2: Measure Level (dB μ V/m) = Reading Level (dB μ V) + Factor (dB/m).

Note 3: Factor (dB/m) = Cable Loss (dB) + Antenna Factor (dB/m) - Pre_Amplifier Gain (dB).

Site: WZ-AC1	Test Date: 2023-09-03
Limit: FCC_5.8G_RE(3m)	Engineer: Carl Jiang
Probe: BBHA9120D_1167_1-18GHz	Polarity: Horizontal
EUT: S1 RC	Power: AC 120V/60Hz
Test Mode: Transmit at 5782MHz Ant 1	

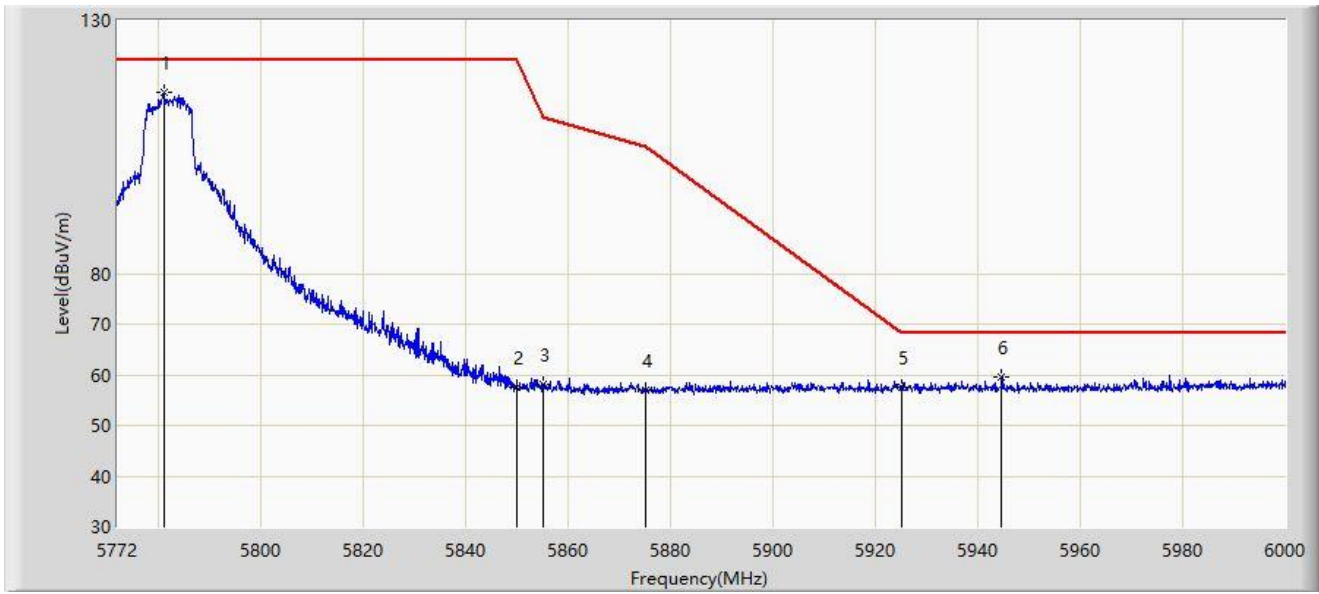

No	Mark	Frequency (MHz)	Measure Level (dB μ V/m)	Reading Level (dB μ V)	Margin (dB)	Limit (dB μ V/m)	Factor (dB/m)	Type
1		5781.006	115.812	111.489	N/A	N/A	4.323	PK
2		5850.000	57.540	52.940	-64.660	122.200	4.599	PK
3		5855.000	58.147	53.587	-52.653	110.800	4.560	PK
4		5875.000	57.040	52.577	-48.160	105.200	4.462	PK
5		5925.000	57.490	52.859	-10.710	68.200	4.631	PK
6	*	5944.710	59.547	55.070	-8.653	68.200	4.477	PK

Note 1: " * ", means this data is the worst emission level.

Note 2: Measure Level (dB μ V/m) = Reading Level (dB μ V) + Factor (dB/m).

Note 3: Factor (dB/m) = Cable Loss (dB) + Antenna Factor (dB/m) - Pre_Amplifier Gain (dB).

Site: WZ-AC1	Test Date: 2023-09-03
Limit: FCC_5.8G_RE(3m)	Engineer: Carl Jiang
Probe: BBHA9120D_1167_1-18GHz	Polarity: Vertical
EUT: S1 RC	Power: AC 120V/60Hz
Test Mode: Transmit at 5782MHz Ant 1	

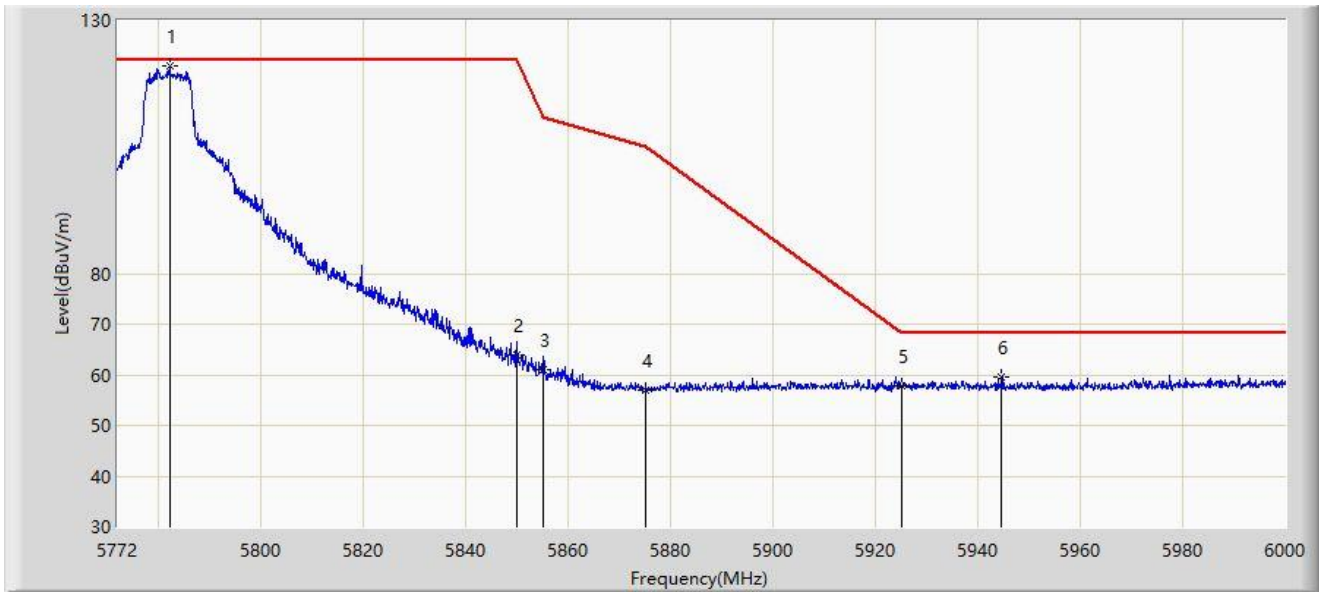

No	Mark	Frequency (MHz)	Measure Level (dB μ V/m)	Reading Level (dB μ V)	Margin (dB)	Limit (dB μ V/m)	Factor (dB/m)	Type
1		5782.146	120.961	116.636	N/A	N/A	4.325	PK
2		5850.000	63.904	59.304	-58.296	122.200	4.599	PK
3		5855.000	60.983	56.423	-49.817	110.800	4.560	PK
4		5875.000	57.040	52.577	-48.160	105.200	4.462	PK
5		5925.000	57.963	53.332	-10.237	68.200	4.631	PK
6	*	5944.710	59.547	55.070	-8.653	68.200	4.477	PK

Note 1: " * ", means this data is the worst emission level.

Note 2: Measure Level (dB μ V/m) = Reading Level (dB μ V) + Factor (dB/m).

Note 3: Factor (dB/m) = Cable Loss (dB) + Antenna Factor (dB/m) - Pre_Amplifier Gain (dB).

Appendix B – Test Setup Photograph

Refer to “2308RSU081-UT” file.

Appendix C – EUT Photograph

Refer to “2308RSU081-UE” file.

————— The End —————