

RF MEASUREMENT REPORT

FCC ID: 2AQVB-PD21A-010P-01
Applicant: Taisync Technology Inc.
Product: Video&Data transmission device
Model No.: PD21A-010P-01
Brand Name: Viulinx
FCC Classification: Digital Transmission System (DTS)
FCC Rule Part(s): Part 15 Subpart C (Section 15.247)
Result: Complies
Received Date: 2023-09-13
Test Date: 2023-09-13 ~ 2023-10-16

Reviewed By:

Jame Yuan

Approved By:

Robin Wu



The test results relate only to the samples tested.

This equipment has been shown to be capable of compliance with the applicable technical standards as indicated in the measurement report and was tested in accordance with the measurement procedures specified in ANSI C63.10-2013. Test results reported herein relate only to the item(s) tested.

The test report shall not be reproduced except in full without the written approval of MRT Technology (Suzhou) Co., Ltd.

Revision History

Report No.	Version	Description	Issue Date	Note
2308RSU079-U1	V01	Initial Report	2023-11-10	Valid

CONTENTS

Description	Page
1. General Information	5
1.1. Applicant	5
1.2. Manufacturer	5
1.3. Testing Facility	5
1.4. Product Information.....	6
1.5. Radio Specification under Test.....	6
1.6. Working Frequencies	6
2. Test Configuration	7
2.1. Test Mode.....	7
2.2. Test System Connection Diagram.....	7
2.3. Test Software	8
2.4. Applied Standards	8
2.5. Test Environment Condition	8
3. Antenna Requirements	9
4. Measuring Instrument	10
5. Decision Rules and Measurement Uncertainty	11
5.1. Decision Rules	11
5.2. Measurement Uncertainty	11
6. Test Result.....	12
6.1. Summary.....	12
6.2. 6dB Bandwidth Measurement.....	13
6.2.1. Test Limit	13
6.2.2. Test Procedure	13
6.2.3. Test Setting	13
6.2.4. Test Setup	13
6.2.5. Test Result	13
6.3. Output Power Measurement	14
6.3.1. Test Limit	14
6.3.2. Test Procedure	14
6.3.3. Test Setting	14
6.3.4. Test Setup	14
6.3.5. Test Result	14
6.4. Power Spectral Density Measurement.....	15
6.4.1. Test Limit	15
6.4.2. Test Procedure	15

6.4.3.	Test Setting	15
6.4.4.	Test Setup	15
6.4.5.	Test Result	16
6.5.	Conducted Band Edge and Out-of-Band Emissions Measurement	17
6.5.1.	Test Limit	17
6.5.2.	Test Procedure	17
6.5.3.	Test Settintg	17
6.5.4.	Test Setup	18
6.5.5.	Test Result	18
6.6.	Radiated Spurious Emission Measurement.....	19
6.6.1.	Test Limit	19
6.6.2.	Test Procedure	19
6.6.3.	Test Setting	19
6.6.4.	Test Setup	21
6.6.5.	Test Result	22
6.7.	Radiated Restricted Band Edge Measurement	23
6.7.1.	Test Limit	23
6.7.2.	Test Procedure	24
6.7.3.	Test Setting	24
6.7.4.	Test Setup	25
6.7.5.	Test Result	25
6.8.	AC Conducted Emissions Measurement	26
6.8.1.	Test Limit	26
6.8.2.	Test Setup	26
6.8.3.	Test Result	26
Appendix A – Test Result		27
A.1	Duty Cycle Test Result	27
A.2	6dB Bandwidth Test Result	28
A.3	Output Power Test Result.....	30
A.4	Power Spectral Density Test Result	31
A.5	Conducted Band Edge and Out-of-Band Emissions Test Result	33
A.6	Radiated Spurious Emission Test Result	38
A.7	Radiated Restricted Band Edge Test Result	42
Appendix B – Test Setup Photograph		58
Appendix C – EUT Photograph		59

1. General Information

1.1. Applicant

Taisync Technology Inc.
2055 Junction Ave. Ste 235, San Jose, CA 95131

1.2. Manufacturer

Wuxi Yuanchuan Rongchuang Technology Co., Ltd
204-01, Second floor, Convention Center, 78 Jinghui East Road, Xinwu District, Wuxi, Jangsu, China

1.3. Testing Facility

<input checked="" type="checkbox"/>	<table border="1" style="width: 100%; border-collapse: collapse;"> <tr> <td colspan="2">Test Site – MRT Suzhou Laboratory</td> </tr> <tr> <td colspan="2">Laboratory Location (Suzhou - Wuzhong)</td> </tr> <tr> <td colspan="2">D8 Building, No.2 Tian'edang Rd., Wuzhong Economic Development Zone, Suzhou, China</td> </tr> <tr> <td colspan="2">Laboratory Location (Suzhou - SIP)</td> </tr> <tr> <td colspan="2">4b Building, Liando U Valley, No.200 Xingpu Rd., Shengpu Town, Suzhou Industrial Park, China</td> </tr> <tr> <td colspan="2">Laboratory Accreditations</td> </tr> <tr> <td>A2LA: 3628.01</td> <td>CNAS: L10551</td> </tr> <tr> <td>FCC: CN1166</td> <td>ISED: CN0001</td> </tr> <tr> <td>VCCI:</td> <td> <input type="checkbox"/>R-20025 <input type="checkbox"/>G-20034 <input type="checkbox"/>C-20020 <input type="checkbox"/>T-20020 <input type="checkbox"/>R-20141 <input type="checkbox"/>G-20134 <input type="checkbox"/>C-20103 <input type="checkbox"/>T-20104 </td> </tr> </table>	Test Site – MRT Suzhou Laboratory		Laboratory Location (Suzhou - Wuzhong)		D8 Building, No.2 Tian'edang Rd., Wuzhong Economic Development Zone, Suzhou, China		Laboratory Location (Suzhou - SIP)		4b Building, Liando U Valley, No.200 Xingpu Rd., Shengpu Town, Suzhou Industrial Park, China		Laboratory Accreditations		A2LA: 3628.01	CNAS: L10551	FCC: CN1166	ISED: CN0001	VCCI:	<input type="checkbox"/> R-20025 <input type="checkbox"/> G-20034 <input type="checkbox"/> C-20020 <input type="checkbox"/> T-20020 <input type="checkbox"/> R-20141 <input type="checkbox"/> G-20134 <input type="checkbox"/> C-20103 <input type="checkbox"/> T-20104
Test Site – MRT Suzhou Laboratory																			
Laboratory Location (Suzhou - Wuzhong)																			
D8 Building, No.2 Tian'edang Rd., Wuzhong Economic Development Zone, Suzhou, China																			
Laboratory Location (Suzhou - SIP)																			
4b Building, Liando U Valley, No.200 Xingpu Rd., Shengpu Town, Suzhou Industrial Park, China																			
Laboratory Accreditations																			
A2LA: 3628.01	CNAS: L10551																		
FCC: CN1166	ISED: CN0001																		
VCCI:	<input type="checkbox"/> R-20025 <input type="checkbox"/> G-20034 <input type="checkbox"/> C-20020 <input type="checkbox"/> T-20020 <input type="checkbox"/> R-20141 <input type="checkbox"/> G-20134 <input type="checkbox"/> C-20103 <input type="checkbox"/> T-20104																		
<input type="checkbox"/>	<table border="1" style="width: 100%; border-collapse: collapse;"> <tr> <td colspan="2">Test Site – MRT Shenzhen Laboratory</td> </tr> <tr> <td colspan="2">Laboratory Location (Shenzhen)</td> </tr> <tr> <td colspan="2">1G, Building A, Junxiangda Building, Zhongshanyuan Road West, Nanshan District, Shenzhen, China</td> </tr> <tr> <td colspan="2">Laboratory Accreditations</td> </tr> <tr> <td>A2LA: 3628.02</td> <td>CNAS: L10551</td> </tr> <tr> <td>FCC: CN1284</td> <td>ISED: CN0105</td> </tr> </table>	Test Site – MRT Shenzhen Laboratory		Laboratory Location (Shenzhen)		1G, Building A, Junxiangda Building, Zhongshanyuan Road West, Nanshan District, Shenzhen, China		Laboratory Accreditations		A2LA: 3628.02	CNAS: L10551	FCC: CN1284	ISED: CN0105						
Test Site – MRT Shenzhen Laboratory																			
Laboratory Location (Shenzhen)																			
1G, Building A, Junxiangda Building, Zhongshanyuan Road West, Nanshan District, Shenzhen, China																			
Laboratory Accreditations																			
A2LA: 3628.02	CNAS: L10551																		
FCC: CN1284	ISED: CN0105																		
<input type="checkbox"/>	<table border="1" style="width: 100%; border-collapse: collapse;"> <tr> <td colspan="2">Test Site – MRT Taiwan Laboratory</td> </tr> <tr> <td colspan="2">Laboratory Location (Taiwan)</td> </tr> <tr> <td colspan="2">No. 38, Fuxing 2nd Rd., Guishan Dist., Taoyuan City 333, Taiwan (R.O.C.)</td> </tr> <tr> <td colspan="2">Laboratory Accreditations</td> </tr> <tr> <td>TAF: 3261</td> <td></td> </tr> <tr> <td>FCC: 291082, TW3261</td> <td>ISED: TW3261</td> </tr> </table>	Test Site – MRT Taiwan Laboratory		Laboratory Location (Taiwan)		No. 38, Fuxing 2nd Rd., Guishan Dist., Taoyuan City 333, Taiwan (R.O.C.)		Laboratory Accreditations		TAF: 3261		FCC: 291082, TW3261	ISED: TW3261						
Test Site – MRT Taiwan Laboratory																			
Laboratory Location (Taiwan)																			
No. 38, Fuxing 2nd Rd., Guishan Dist., Taoyuan City 333, Taiwan (R.O.C.)																			
Laboratory Accreditations																			
TAF: 3261																			
FCC: 291082, TW3261	ISED: TW3261																		

1.4. Product Information

Product Name	Video&Data transmission device
Model No.	PD21A-010P-01
EUT Identification No	20230913Sample#04
Wireless Specification	2417 ~ 2470MHz & 5731 ~ 5782MHz
Antenna Information	Refer to selection 1.5
Working Voltage	DC12-26V, Typically DC18V
Operating Temperature	-40 ~ 65°C
<p>Note 1: The information of EUT was provided by the manufacturer, and the accuracy of the information shall be the responsibility of the manufacturer.</p> <p>Note 2. There are two antenna ports of the EUT, and the two antenna ports could not transmit simultaneous.</p> <p>Note 3. This model includes both air and ground EUTs, the hardware and RF parts are exactly the same, only the air EUT has been tested.</p>	

1.5. Radio Specification under Test

Frequency Range	2417 ~ 2470MHz
Channel Number	3
Type of Modulation	OFDM
Data Rate	Upstream: 600kbps Downstream: 2.08~7.78Mbps
Antenna Type	Dipole Antenna
Antenna Gain	5.0 dBi

1.6. Working Frequencies

Low Channel	Mid Channel	High Channel
2417 MHz	2444 MHz	2470 MHz

2. Test Configuration

2.1. Test Mode

Mode 1: Transmit at 2417MHz - SISO Mode (Ant 0).
Mode 2: Transmit at 2444MHz - SISO Mode (Ant 0).
Mode 3: Transmit at 2470MHz - SISO Mode (Ant 0).
Mode 4: Transmit at 2417MHz - SISO Mode (Ant 1).
Mode 5: Transmit at 2444MHz - SISO Mode (Ant 1).
Mode 6: Transmit at 2470MHz - SISO Mode (Ant 1).

2.2. Test System Connection Diagram

The device was tested per the guidance ANSI C63.10: 2013 was used to reference the appropriate EUT setup for radiated emissions testing.

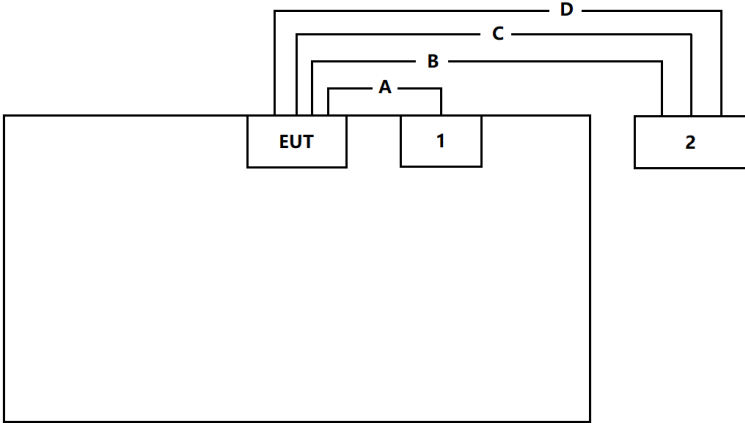
Connection Diagram			
			
Cable Type		Cable Description	Length
A	Power Cable	Non shielded	1.8m
B	LAN Cable	Non shielded	>10m
C	USB Cable	Shielding	>10m
D	Type-C Cable	Shielding	>10m
Product		Manufacturer	Model No.
1	Adapter	FLYPOWER	PS12T120K1000ED
2	Notebook	Lenovo	E430C

2.3. Test Software

The EUT could transmit through specific web pages provided by the customer.
Final power setting please refer to operational description.

2.4. Applied Standards

According to the specifications of the manufacturer, the EUT must comply with the requirements of the following standards:

- FCC Part 15.247
- KDB 558074 D01v05r02
- ANSI C63.10-2013

2.5. Test Environment Condition

Ambient Temperature	15 ~ 35°C
Relative Humidity	20 ~ 75%RH

3. Antenna Requirements

Excerpt from §15.203 of the FCC Rules/Regulations:

“An intentional radiator antenna shall be designed to ensure that no antenna other than that furnished by the responsible party can be used with the device. The use of a permanently attached antenna or of an antenna that uses a unique coupling to the intentional radiator shall be considered sufficient to comply with the provisions of this section.”

- The product is defined as the professional installation of equipment by the manufacturer, there is no necessary to comply with the requirement of §15.203.

4. Measuring Instrument

Instrument	Manufacturer	Model No.	Asset No.	Cali. Interval	Cali. Due Date	Test Site
EMI Test Receiver	R&S	ESR7	MRTSUE06001	1 year	2023-12-28	WZ-AC1
Signal Analyzer	Keysight	N9010B	MRTSUE06607	1 year	2023-12-28	WZ-AC1
TRILOG Antenna	Schwarzbeck	VULB 9168	MRTSUE06172	1 year	2024-06-09	WZ-AC1
Horn Antenna	Schwarzbeck	BBHA 9120D	MRTSUE06023	1 year	2024-08-09	WZ-AC1
Horn Antenna	Schwarzbeck	BBHA 9170	MRTSUE06597	1 year	2023-11-05	WZ-AC1
Preamplifier	EMCI	EMC184045SE	MRTSUE06640	1 year	2024-01-12	WZ-AC1
Thermohygrometer	testo	608-H1	MRTSUE06403	1 year	2024-05-31	WZ-AC1
Thermohygrometer	testo	608-H1	MRTSUE11039	1 year	2023-11-01	WZ-AC1
Anechoic Chamber	TDK	WZ-AC1	MRTSUE06212	1 year	2024-04-20	WZ-AC1
EMI Test Receiver	Agilent	N9038A	MRTSUE06125	1 year	2024-05-23	WZ-AC2
Loop Antenna	Schwarzbeck	FMZB 1519	MRTSUE06025	1 year	2024-09-17	WZ-AC2
Horn Antenna	Schwarzbeck	BBHA 9120D	MRTSUE06171	1 year	2024-10-12	WZ-AC2
Preamplifier	Schwarzbeck	BBV 9718	MRTSUE06176	1 year	2024-05-07	WZ-AC2
Thermohygrometer	Mingle	ETH529	MRTSUE06170	1 year	2023-11-27	WZ-AC2
Thermohygrometer	testo	608-H1	MRTSUE11038	1 year	2023-11-01	WZ-AC2
Anechoic Chamber	RIKEN	WZ-AC2	MRTSUE06213	1 year	2024-04-20	WZ-AC2
USB Power Sensor	Keysight	U2021XA	MRTSUE06446	1 year	2024-05-23	WZ-SR4
Signal Analyzer	Keysight	N9010B	MRTSUE06457	1 year	2024-05-23	WZ-SR4
Attenuator	MVE	MVE2213	MRTSUE11088	1 year	2024-06-08	WZ-SR4
Shielding Room	HUAMING	WZ-SR4	MRTSUE06441	N/A	N/A	WZ-SR4

Software	Version	Function
EMI Software	V3.0.0	EMI Test Software
Controller_MF 7802	2.03C	RE Antenna & Turntable
Controller_MF 7802	1.02	RE Antenna & Turntable
BenchVue Power Meter	2018.1	Power

5. Decision Rules and Measurement Uncertainty

5.1. Decision Rules

The Decision Rule is based on Simple Acceptance in accordance with ISO Guide 98-4: 2012 Clause 8.2. (Measurement uncertainty is not taken into account when stating conformity with a specified requirement.)

5.2. Measurement Uncertainty

Where relevant, the following test uncertainty levels have been estimated for tests performed on the EUT as specified in CISPR 16-4-2. This uncertainty represents an expanded uncertainty expressed at approximately the 95% confidence level using a coverage factor of $k = 2$.

Radiated Emission Measurement
<p>The maximum measurement uncertainty is evaluated as:</p> <p>Coaxial: 9kHz~30MHz: 2.61dB</p> <p>Coplanar: 9kHz~30MHz: 2.62dB</p> <p>Horizontal: 30MHz~200MHz: 3.79dB</p> <p> 200MHz~1GHz: 3.91dB</p> <p> 1GHz~40GHz: 4.99dB</p> <p>Vertical: 30MHz~200MHz: 4.06dB</p> <p> 200MHz~1GHz: 5.21dB</p> <p> 1GHz~40GHz: 4.90dB</p>
Spurious Emissions, Conducted
<p>Measuring Uncertainty for a Level of Confidence of 95% ($U=2Uc(y)$):</p> <p>2.2dB</p>
Output Power
<p>Measuring Uncertainty for a Level of Confidence of 95% ($U=2Uc(y)$):</p> <p>1.4dB</p>
Power Spectrum Density
<p>Measuring Uncertainty for a Level of Confidence of 95% ($U=2Uc(y)$):</p> <p>2.2dB</p>
Occupied Bandwidth
<p>Measuring Uncertainty for a Level of Confidence of 95% ($U=2Uc(y)$):</p> <p>2.7%</p>

6. Test Result

6.1. Summary

FCC Section(s)	Test Description	Test Condition	Verdict
15.247(a)(2)	6dB Bandwidth	Conducted	Pass
15.247(b)(3)	Output Power		Pass
15.247(e)	Power Spectral Density		Pass
15.247(d)	Band Edge / Out-of-Band Emissions		Pass
15.205 15.209	General Field Strength (Restricted Bands and Radiated Emission)	Radiated	Pass
15.207	AC Conducted Emissions 150kHz - 30MHz	Line Conducted	N/A

Notes:

- The analyzer plots shown in this section were all taken with a correction table loaded into the analyzer. The correction table was used to account for the losses of the cables and attenuators used as part of the system to connect the EUT to the analyzer at all frequencies of interest.
- For radiated emission tests, every axis (X, Y, Z) was also verified. The test results shown in the following sections represent the worst-case emissions.
- "N/A" means this item is not applicable, and the details refer to relevant section.

6.2. 6dB Bandwidth Measurement

6.2.1. Test Limit

The minimum 6dB bandwidth shall be at least 500 kHz.

6.2.2. Test Procedure

ANSI C63.10 - 2013 - Section 11.8

6.2.3. Test Setting

1. The Spectrum's automatic bandwidth measurement capability was used to perform the 6dB bandwidth measurement. The "X" dB bandwidth parameter was set to $X = 6$. The bandwidth measurement was not influenced by any intermediate power nulls in the fundamental emission.
2. Set RBW = 100 kHz
3. VBW $\geq 3 \times$ RBW
4. Detector = Peak
5. Trace mode = Max hold
6. Sweep = Auto couple
7. Allow the trace to stabilize.

6.2.4. Test Setup

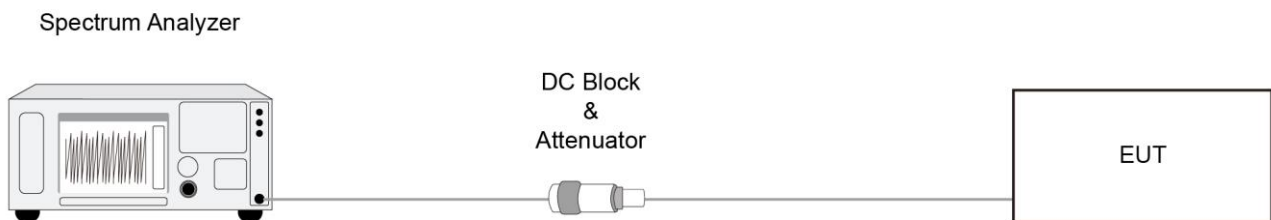

6.2.5. Test Result

Refer to Appendix A.2.

6.3. Output Power Measurement

6.3.1. Test Limit

The maximum output power shall be less 1 Watt (30dBm).

The conducted output power limit specified in paragraph FCC Part 15.247(b) of this section is based on the use of antennas with directional gains that do not exceed 6 dBi. If transmitting antennas of directional gain greater than 6 dBi are used, the conducted output power from the intentional radiator shall be reduced below the stated values in paragraphs FCC Part 15.247(b)(3) of this section, as appropriate, by the amount in dB that the directional gain of the antenna exceeds 6 dBi.

6.3.2. Test Procedure

ANSI C63.10 - 2013 - Section 11.9.2.3.2

6.3.3. Test Setting

Average Power Measurement

Average power measurements were performed only when the EUT was transmitting at its maximum power control level using a broadband power meter with a pulse sensor. The power meter implemented triggering and gating capabilities which were set up such that power measurements were recorded only during the ON time of the transmitter.

6.3.4. Test Setup

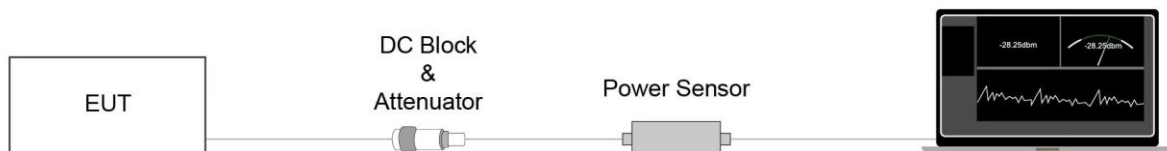

6.3.5. Test Result

Refer to Appendix A.3.

6.4. Power Spectral Density Measurement

6.4.1. Test Limit

The maximum permissible power spectral density is 8dBm in any 3 kHz band.

The same method of determining the conducted output power shall be used to determine the power spectral density.

6.4.2. Test Procedure

ANSI C63.10 - 2013 - Section 11.10.5

6.4.3. Test Setting

1. Measure the duty cycle (x) of the transmitter output signal.
2. Set instrument center frequency to DTS channel center frequency.
3. Set span to at least 1.5 times the OBW.
4. RBW = 10 kHz.
5. VBW = 30 kHz.
6. Detector = RMS.
7. Ensure that the number of measurement points in the sweep $\geq 2 \times \text{span}/\text{RBW}$.
8. Sweep time = auto couple.
9. Don't use sweep triggering. Allow sweep to "free run".
10. Employ trace averaging (RMS) mode over a minimum of 100 traces.
11. Use the peak marker function to determine the maximum amplitude level.
12. Add $10 \log (1/x)$, where x is the duty cycle measured in step (a), to the measured PSD to compute the average PSD during the actual transmission time. If measured value exceeds requirement specified by regulatory agency, then reduce RBW (but no less than 3 kHz) and repeat (note that this may require zooming in on the emission of interest and reducing the span to meet the minimum measurement point requirement as the RBW is reduced).

6.4.4. Test Setup

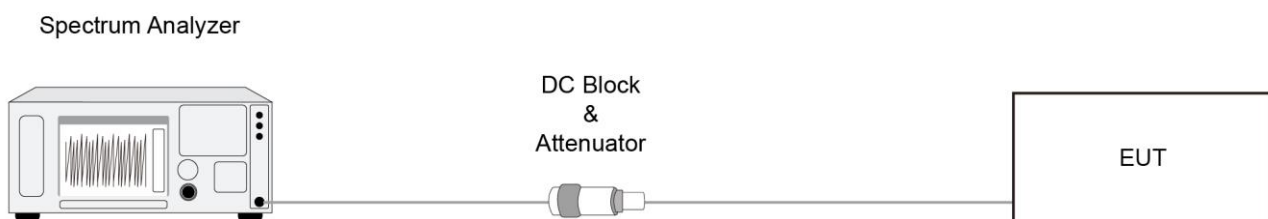

6.4.5. Test Result

Refer to Appendix A.4.

6.5. Conducted Band Edge and Out-of-Band Emissions Measurement

6.5.1. Test Limit

The limit for out-of-band spurious emissions at the band edge is 30dB below the fundamental emission level, as determined from the in-band power measurement of the DTS channel performed in a 100 kHz bandwidth per the PSD procedure.

6.5.2. Test Procedure

ANSI C63.10-2013 - Section 11.11

6.5.3. Test Setting

Reference level measurement

1. Set instrument center frequency to DTS channel center frequency
2. Set the span to ≥ 1.5 times the DTS bandwidth
3. Set the RBW = 100 kHz
4. Set the VBW $\geq 3 \times$ RBW
5. Detector = peak
6. Sweep time = auto couple
7. Trace mode = max hold
8. Allow trace to fully stabilize

Emission level measurement

1. Set the center frequency and span to encompass frequency range to be measured
2. RBW = 100kHz
3. VBW = 300kHz
4. Detector = Peak
5. Trace mode = max hold
6. Sweep time = auto couple
7. The trace was allowed to stabilize

6.5.4. Test Setup

Spectrum Analyzer

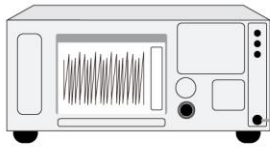

DC Block
&
Attenuator



6.5.5. Test Result

Refer to Appendix A.5.

6.6. Radiated Spurious Emission Measurement

6.6.1. Test Limit

All out of band emissions appearing in a restricted band as specified in Section 15.205 of the Title 47 CFR must not exceed the limits shown in Table per Section 15.209.

FCC Part 15 Subpart C Paragraph 15.209		
Frequency [MHz]	Field Strength [$\mu\text{V/m}$]	Measured Distance [Meters]
0.009 - 0.490	2400/F (kHz)	300
0.490 - 1.705	24000/F (kHz)	30
1.705 - 30	30	30
30 - 88	100	3
88 - 216	150	3
216 - 960	200	3
Above 960	500	3

6.6.2. Test Procedure

ANSI C63.10 - 2013 - Section 11.11 & 11.12

ANSI C63.10 - 2013 - Section 6.3 (General Requirements)

ANSI C63.10 - 2013 - Section 6.4 (Standard test method below 30MHz)

ANSI C63.10 - 2013 - Section 6.5 (Standard test method above 30MHz to 1GHz)

ANSI C63.10 - 2013 - Section 6.6 (Standard test method above 1GHz)

6.6.3. Test Setting

Table 1 - RBW as a function of frequency

Frequency	RBW
9 ~ 150 kHz	200 ~ 300 Hz
0.15 ~ 30 MHz	9 ~ 10 kHz
30 ~ 1000 MHz	100 ~ 120 kHz
> 1000MHz	1MHz

Quasi-Peak Measurements below 1GHz

1. Analyzer center frequency was set to the frequency of the radiated spurious emission of interest
2. Span was set greater than 1MHz
3. RBW = as specified in Table 1
4. Detector = CISPR quasi-peak
5. Sweep time = auto couple
6. Trace was allowed to stabilize

Peak Measurements above 1GHz

1. Analyzer center frequency was set to the frequency of the radiated spurious emission of interest
2. RBW = 1MHz
3. VBW = 3MHz
4. Detector = peak
5. Sweep time = auto couple
6. Trace mode = max hold
7. Trace was allowed to stabilize

Average Measurements above 1GHz (Method VB)

1. Analyzer center frequency was set to the frequency of the radiated spurious emission of interest
2. RBW = 1MHz
3. VBW; If the EUT is configured to transmit with duty cycle $\geq 98\%$, set VBW = 10 Hz.
If the EUT duty cycle is $< 98\%$, set VBW $\geq 1/T$. T is the minimum transmission duration.
4. Detector = Peak
5. Sweep time = auto
6. Trace mode = max hold
7. Trace was allowed to stabilize

6.6.4. Test Setup

Below 30MHz Test Setup:

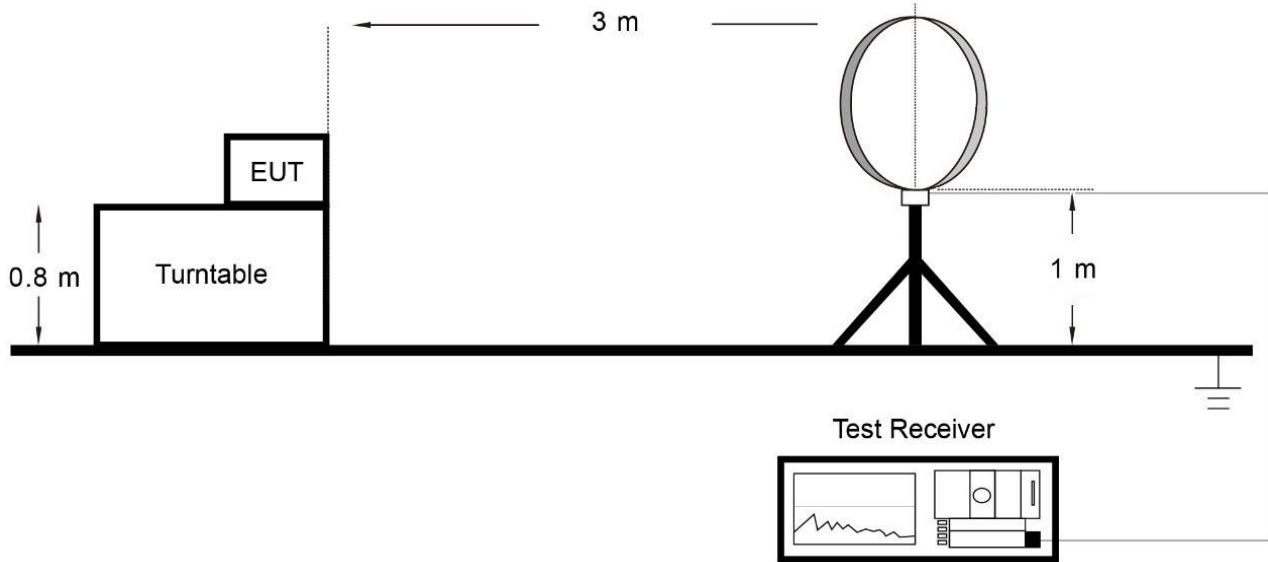

Below 1GHz Test Setup:

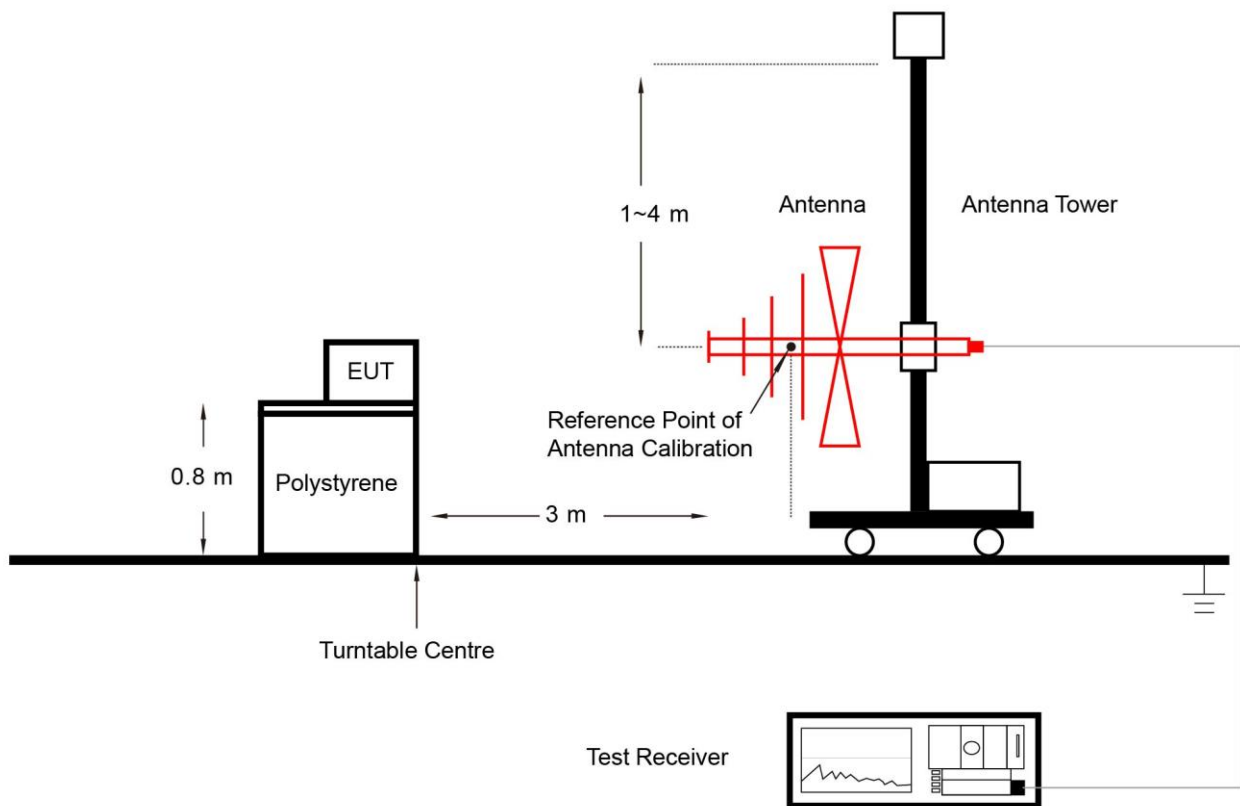

Above 1GHz Test Setup:

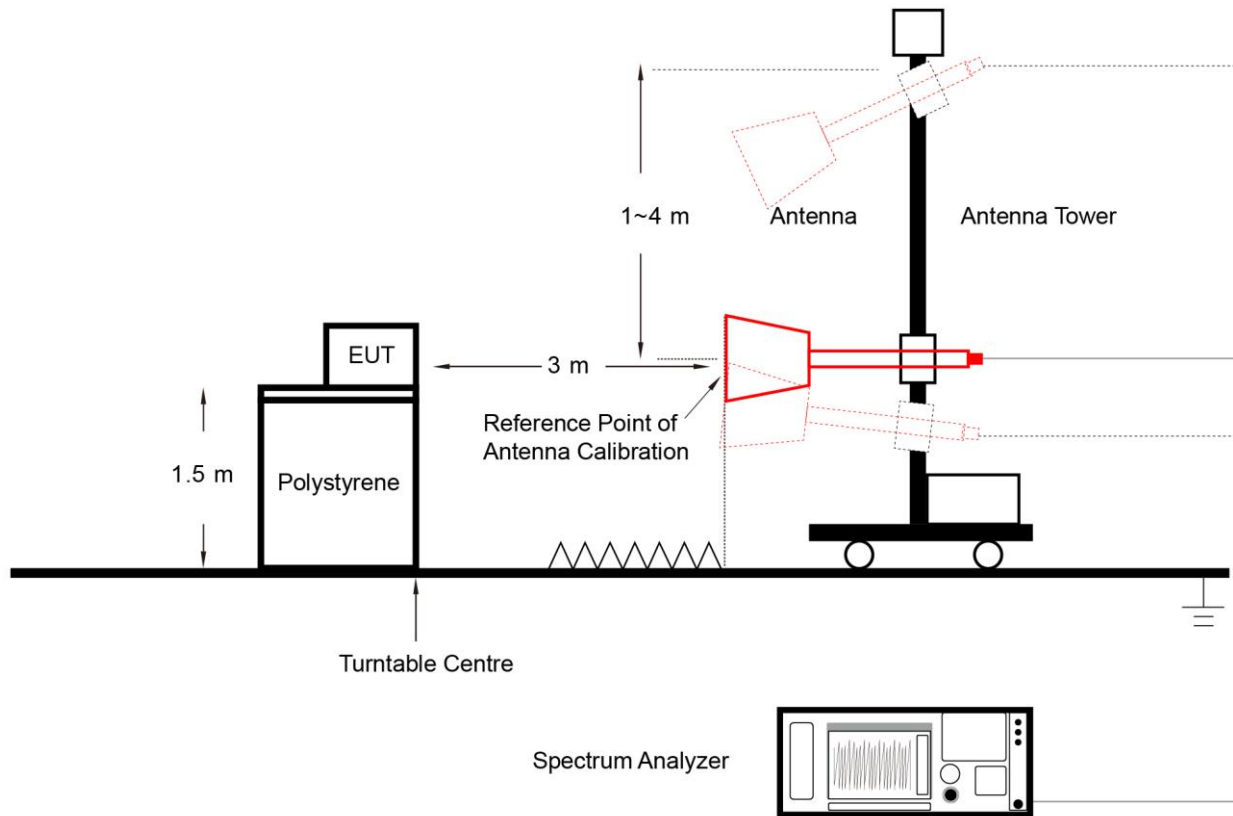

6.6.5. Test Result

Refer to Appendix A.6.

6.7. Radiated Restricted Band Edge Measurement

6.7.1. Test Limit

For 15.205 requirement:

Radiated emissions which fall in the restricted bands, as defined in Section 15.205(a) of FCC part 15, must also comply with the radiated emission limits specified in Section 15.209(a).

Frequency (MHz)	Frequency (MHz)	Frequency (MHz)	Frequency (GHz)
0.090 - 0.110	16.42 - 16.423	399.9 - 410	4.5 - 5.15
¹ 0.495 - 0.505	16.69475 - 16.69525	608 - 614	5.35 - 5.46
2.1735 - 2.1905	16.80425 - 16.80475	960 - 1240	7.25 - 7.75
4.125 - 4.128	25.5 - 25.67	1300 - 1427	8.025 - 8.5
4.17725 - 4.17775	37.5 - 38.25	1435 - 1626.5	9.0 - 9.2
4.20725 - 4.20775	73 - 74.6	1645.5 - 1646.5	9.3 - 9.5
6.215 - 6.218	74.8 - 75.2	1660 - 1710	10.6 - 12.7
6.26775 - 6.26825	108 - 121.94	1718.8 - 1722.2	13.25 - 13.4
6.31175 - 6.31225	123 - 138	2200 - 2300	14.47 - 14.5
8.291 - 8.294	149.9 - 150.05	2310 - 2390	15.35 - 16.2
8.362 - 8.366	156.52475 - 156.52525	2483.5 - 2500	17.7 - 21.4
8.37625 - 8.38675	156.7 - 156.9	2690 - 2900	22.01 - 23.12
8.41425 - 8.41475	162.0125 - 167.17	3260 - 3267	23.6 - 24.0
12.29 - 12.293	167.72 - 173.2	3332 - 3339	31.2 - 31.8
12.51975 - 12.52025	240 - 285	3345.8 - 3358	36.43 - 36.5
12.57675 - 12.57725	322 - 335.4	3600 - 4400	(²)
13.36 - 13.41	--	--	--

All out of band emissions appearing in a restricted band as specified in Section 15.205 of the Title 47CFR must not exceed the limits shown in Table per Section 15.209.

FCC Part 15 Subpart C Paragraph 15.209		
Frequency [MHz]	Field Strength [$\mu\text{V/m}$]	Measured Distance [Meters]
0.009 - 0.490	2400/F (kHz)	300
0.490 - 1.705	24000/F (kHz)	30
1.705 - 30	30	30
30 - 88	100	3
88 - 216	150	3
216 - 960	200	3
Above 960	500	3

6.7.2. Test Procedure

ANSI C63.10-2013 Section 6.3 & 6.6 & 11.13

6.7.3. Test Setting

Peak Field Strength Measurements

1. Analyzer center frequency was set to the frequency of the radiated spurious emission of interest
2. RBW = 1MHz
3. VBW = 3MHz
4. Detector = peak
5. Sweep time = auto couple
6. Trace mode = max hold
7. Trace was allowed to stabilize

Average Field Strength Measurements

1. Analyzer center frequency was set to the frequency of the radiated spurious emission of interest
2. RBW = 1MHz
3. VBW $\geq 1/T$
4. As an alternative, the instrument may be set to linear detector mode. Ensure that video filtering is applied in linear voltage domain (rather than in a log or dB domain). Some instruments require linear display mode in order to accomplish this. Others have a setting for Average-VBW Type, which can be set to "Voltage" regardless of the display mode
5. Detector = Peak
6. Sweep time = auto
7. Trace mode = max hold
8. Allow max hold to run for at least 50 times (1/duty cycle) traces

6.7.4. Test Setup

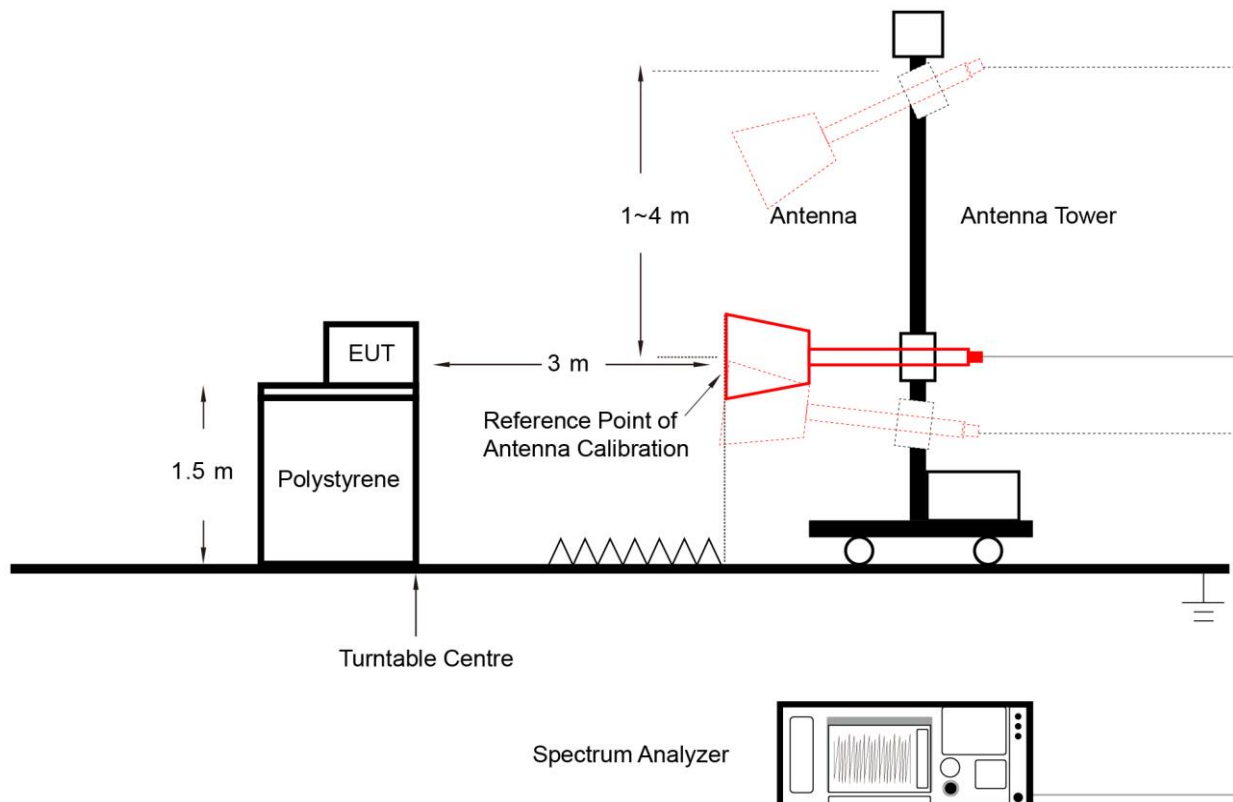

6.7.5. Test Result

Refer to Appendix A.7.

6.8. AC Conducted Emissions Measurement

6.8.1. Test Limit

FCC Part 15 Subpart C Paragraph 15.207 Limits		
Frequency (MHz)	QP (dB μ V)	AV (dB μ V)
0.15 - 0.50	66 - 56	56 - 46
0.50 - 5.0	56	46
5.0 - 30	60	50

Note 1: The lower limit shall apply at the transition frequencies.

Note 2: The limit decreases linearly with the logarithm of the frequency in the range 0.15MHz to 0.5MHz.

6.8.2. Test Setup

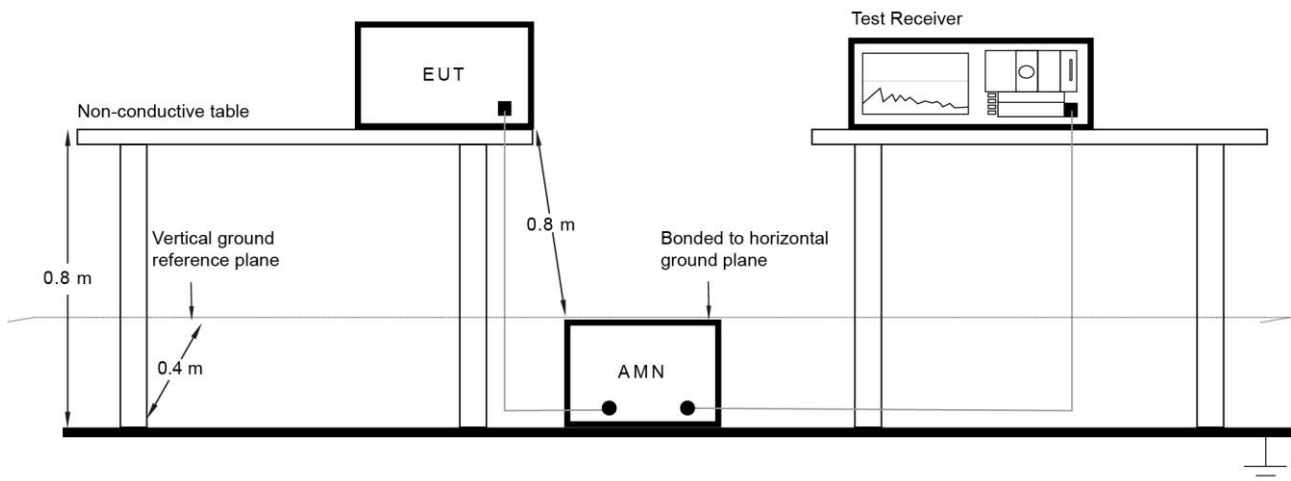

6.8.3. Test Result

The device is powered by battery in actual use, so this test item is not applicable.

Appendix A – Test Result

A.1 Duty Cycle Test Result

Test Site	WZ-SR4	Test Engineer	Jeff Yang
Test Date	2023-09-15		

Duty Cycle	92.12%
------------	--------

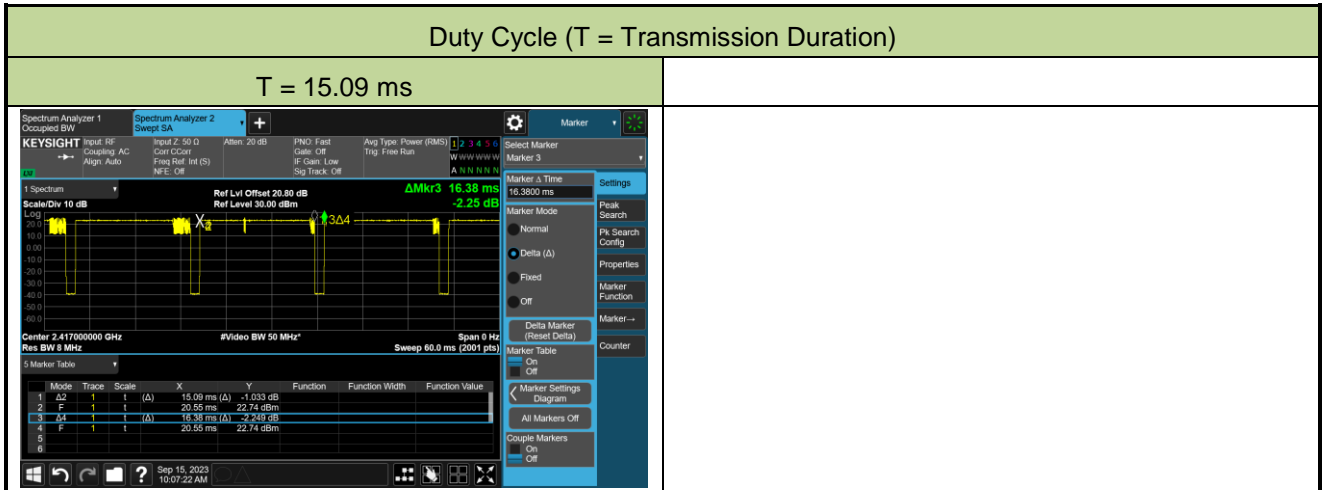

A.2 6dB Bandwidth Test Result

Test Site	WZ-SR4	Test Engineer	Jeff Yang
Test Date	2023-09-15		

Frequency (MHz)	6dB Bandwidth (MHz)	Limit (MHz)
SISO Mode - Ant 0		
2417	9.060	≥ 0.5
2444	9.079	≥ 0.5
2470	9.063	≥ 0.5
SISO Mode - Ant 1		
2417	9.069	≥ 0.5
2444	9.036	≥ 0.5
2470	9.042	≥ 0.5

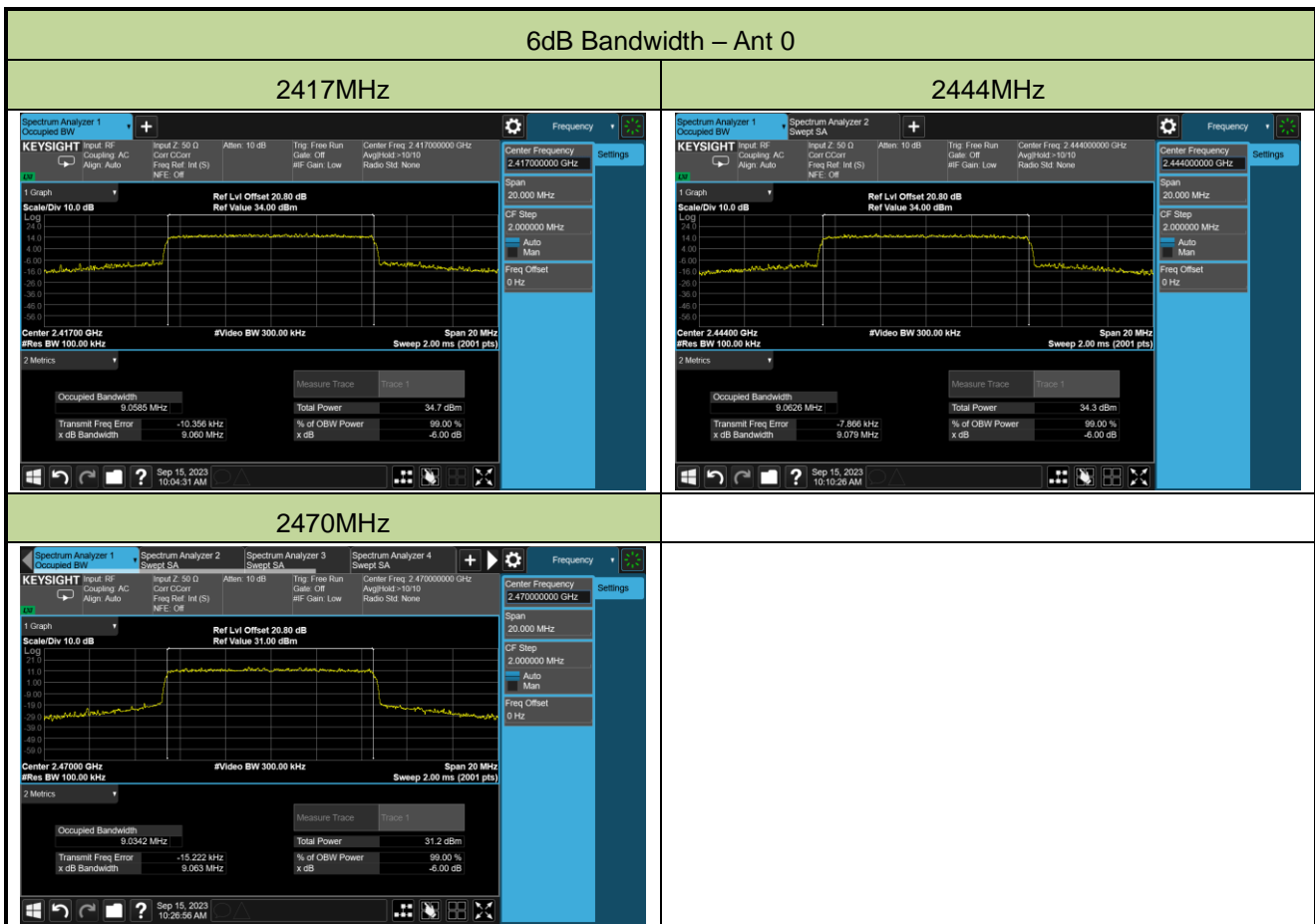



A.3 Output Power Test Result

Test Site	WZ-SR4	Test Engineer	Jeff Yang
Test Date	2023-09-13		

Freq. (MHz)	Average Power (dBm)		Limit (dBm)
	Ant 0	Ant 1	
2417	24.71	25.53	≤ 30.00
2444	25.03	25.67	≤ 30.00
2470	22.05	22.12	≤ 30.00

A.4 Power Spectral Density Test Result

Test Site	WZ-SR4	Test Engineer	Jeff Yang
Test Date	2023-09-15		

Freq. (MHz)	AV PSD (dBm/10kHz)		Duty Cycle (%)	10*log(1/x)	Total PSD (dBm/10kHz)		Limit (dBm/3kHz)
	Ant 0	Ant 1			Ant 0	Ant 1	
2417	-4.190	-3.480	92.12	0.356	-3.834	-3.124	≤ 8.00
2444	-3.635	-4.573	92.12	0.356	-3.279	-4.217	≤ 8.00
2470	-6.694	-6.470	92.12	0.356	-6.338	-6.114	≤ 8.00

Note: When EUT duty cycle < 98%, Total PSD (dBm/10kHz) = AV PSD (dBm/10kHz) + 10*log (1/Duty Cycle).

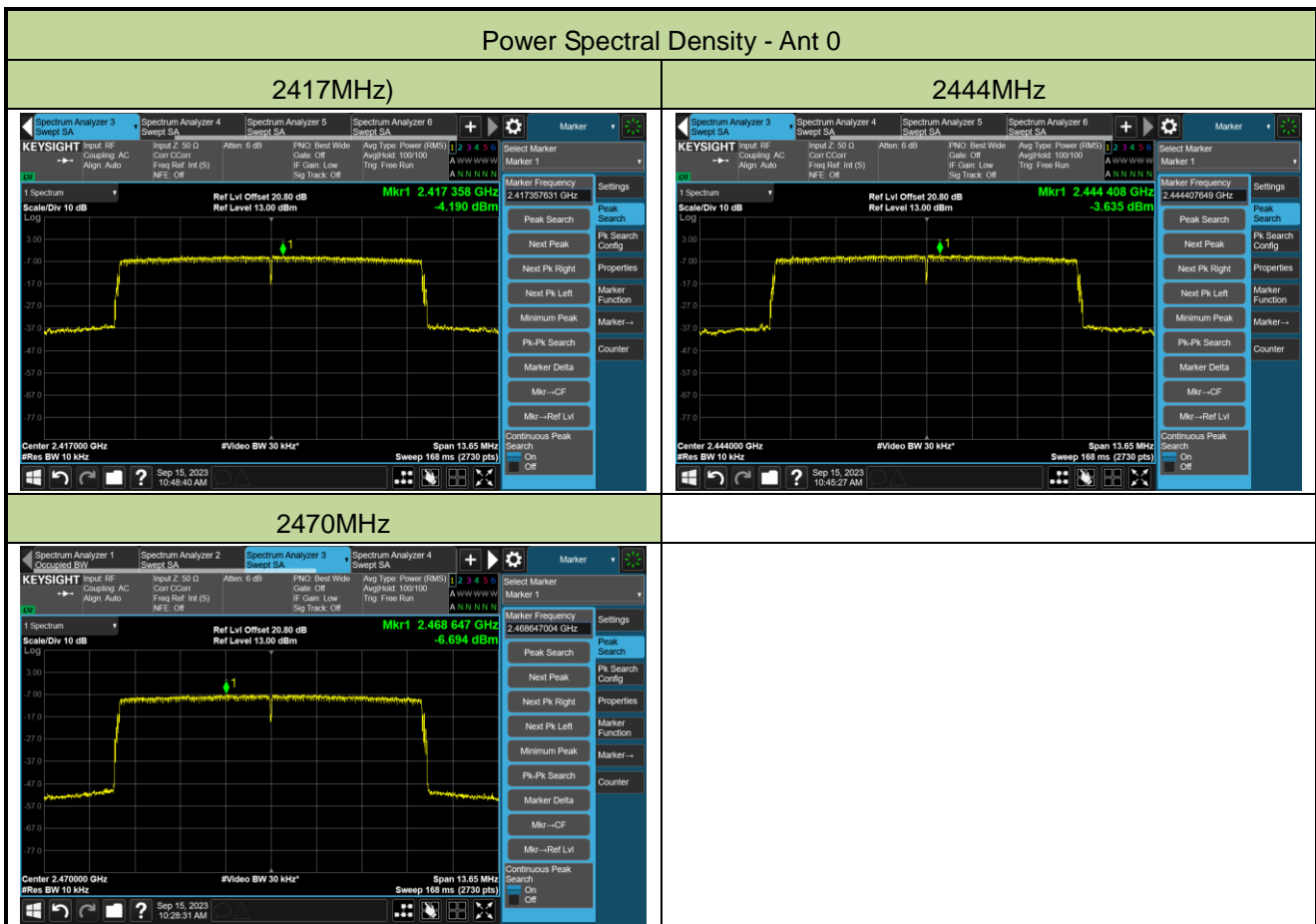

Power Spectral Density - Ant 1

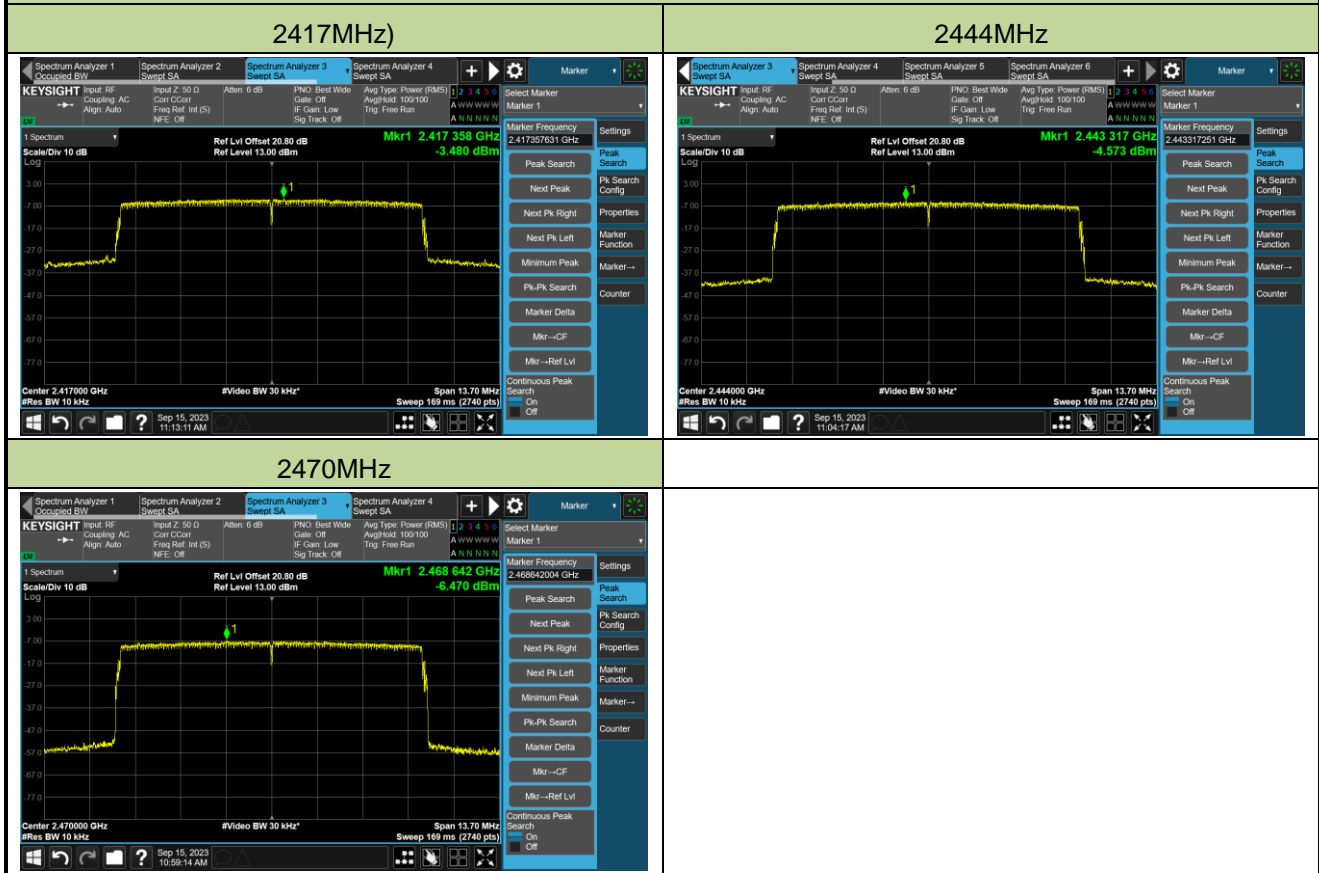

A.5 Conducted Band Edge and Out-of-Band Emissions Test Result

Test Site	WZ-SR4	Test Engineer	Jeff Yang
Test Date	2023-09-15		

Frequency (MHz)	Limit
2417	30dBc
2444	30dBc
2470	30dBc

Out-of-Band Emissions – Ant 0

2417MHz

Reference Level

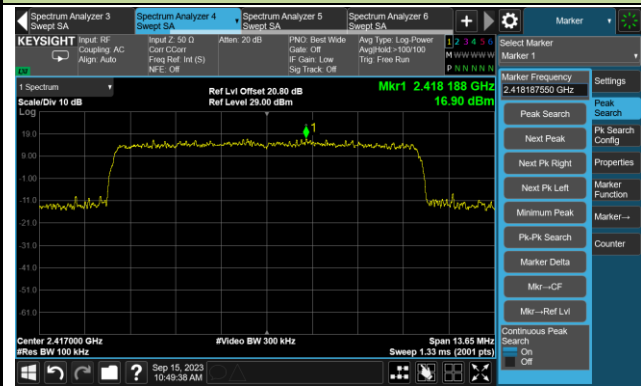

Low Band Edge

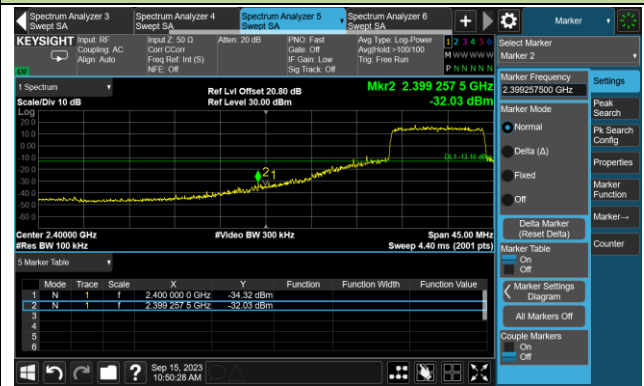

Spurious Emission



2444MHz

Reference Level

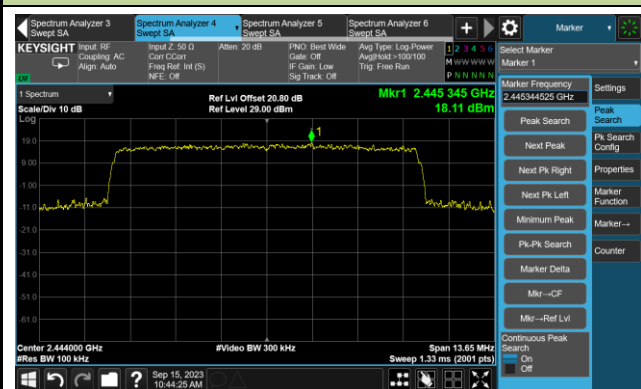

Spurious Emission



Out-of-Band Emissions – Ant 0

2470MHz

Reference Level

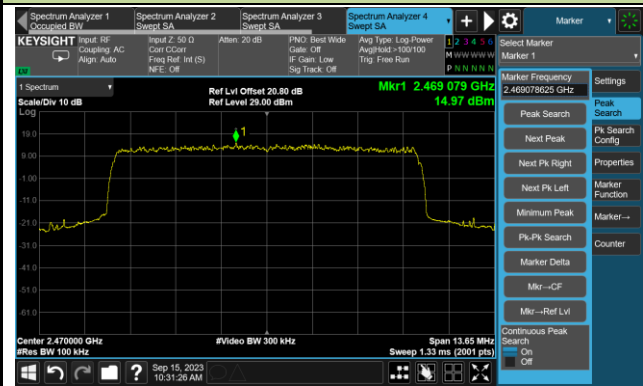

High Band Edge

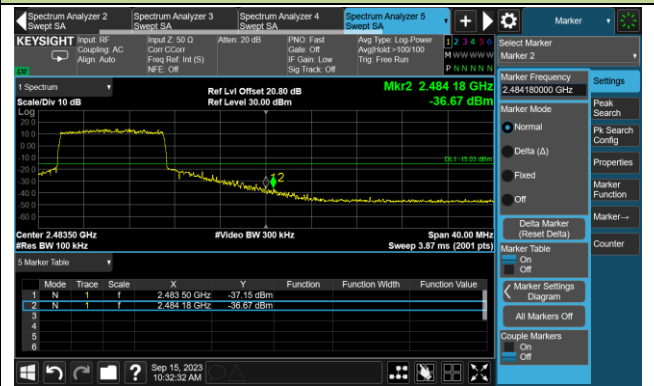

Spurious Emission



Out-of-Band Emissions – Ant 1

2417MHz

Reference Level

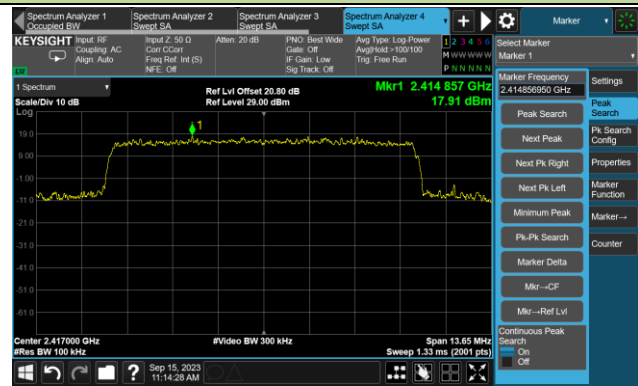

Low Band Edge

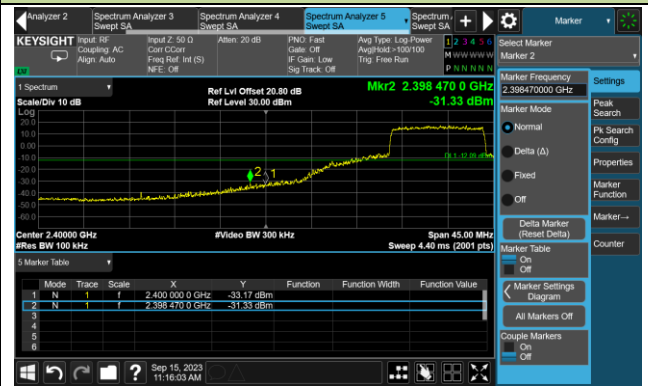

Spurious Emission



2444MHz

Reference Level

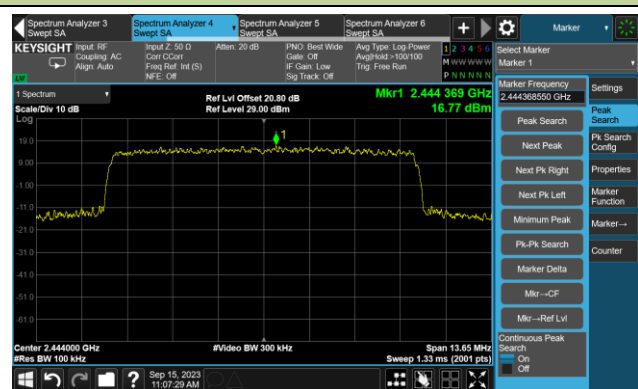

Spurious Emission



Out-of-Band Emissions – Ant 1

2470MHz

Reference Level

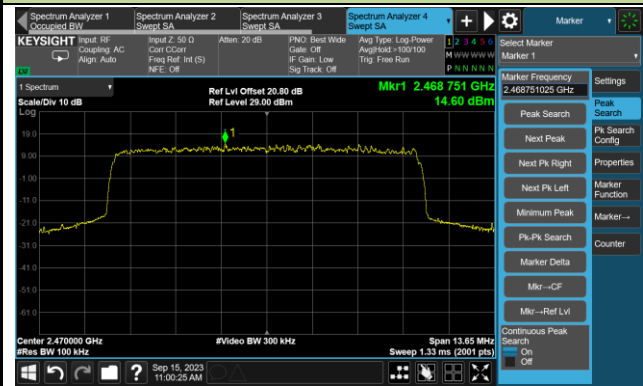

High Band Edge



Spurious Emission



A.6 Radiated Spurious Emission Test Result

Test Site	WZ-AC2	Test Engineer	Dick Shen
Test Date	2023-09-28	Test Mode	SISO Mode Ant 0
Remark:	1. Average measurement was not performed if peak level lower than average limit. 2. Other frequency was 20dB below limit line within 1-18GHz, there is not show in the report.		

Test Freq.	Frequency (MHz)	Reading Level (dBμV)	Factor (dB/m)	Measure Level (dBμV/m)	Limit (dBμV/m)	Margin (dB)	Detector	Polarization
2417MHz	4833.5	42.1	3.1	45.2	74.0	-28.8	Peak	Horizontal
	7468.5	31.2	12.1	43.3	74.0	-30.7	Peak	Horizontal
	12262.5	31.9	17.3	49.2	74.0	-24.8	Peak	Horizontal
	4833.5	40.4	3.1	43.5	74.0	-30.5	Peak	Vertical
	8157.0	33.1	11.5	44.6	74.0	-29.4	Peak	Vertical
	11497.5	30.9	17.5	48.4	74.0	-25.6	Peak	Vertical
2444MHz	4884.5	45.1	3.0	48.1	74.0	-25.9	Peak	Horizontal
	7332.5	39.2	11.4	50.6	74.0	-23.4	Peak	Horizontal
	11548.5	31.5	17.6	49.1	74.0	-24.9	Peak	Horizontal
	4884.5	42.4	3.0	45.4	74.0	-28.6	Peak	Vertical
	7332.5	34.9	11.4	46.3	74.0	-27.7	Peak	Vertical
	11625.0	31.5	17.4	48.9	74.0	-25.1	Peak	Vertical
2470MHz	4935.5	35.7	3.2	38.9	74.0	-35.1	Peak	Horizontal
	7417.5	37.9	11.7	49.6	74.0	-24.4	Peak	Horizontal
	11489.0	30.6	17.6	48.2	74.0	-25.8	Peak	Horizontal
	4179.0	36.0	0.9	36.9	74.0	-37.1	Peak	Vertical
	4587.0	34.8	2.3	37.1	74.0	-36.9	Peak	Vertical
	11642.0	31.1	17.7	48.8	74.0	-25.2	Peak	Vertical

Note: Measure Level (dBμV/m) = Reading Level (dBμV) + Factor (dB/m)

Factor (dB/m) = Cable Loss (dB) + Antenna Factor (dB/m) - Pre_Amplifier Gain (dB)

Test Site	WZ-AC2	Test Engineer	Dick Shen
Test Date	2023-09-28	Test Mode	SISO Mode Ant 1
Remark:	1. Average measurement was not performed if peak level lower than average limit. 2. Other frequency was 20dB below limit line within 1-18GHz, there is not show in the report.		

Test Freq.	Frequency (MHz)	Reading Level (dB μ V)	Factor (dB/m)	Measure Level (dB μ V/m)	Limit (dB μ V/m)	Margin (dB)	Detector	Polarization
2417MHz	4833.5	45.6	3.1	48.7	74.0	-25.3	Peak	Horizontal
	8199.5	32.6	11.4	44.0	74.0	-30.0	Peak	Horizontal
	11098.0	33.0	17.0	50.0	74.0	-24.0	Peak	Horizontal
	4833.5	38.3	3.1	41.4	74.0	-32.6	Peak	Vertical
	8259.0	33.0	11.2	44.2	74.0	-29.8	Peak	Vertical
	11514.5	31.8	17.2	49.0	74.0	-25.0	Peak	Vertical
2444MHz	4884.5	41.0	3.0	44.0	74.0	-30.0	Peak	Horizontal
	7332.5	35.5	11.4	46.9	74.0	-27.1	Peak	Horizontal
	11497.5	32.8	17.5	50.3	74.0	-23.7	Peak	Horizontal
	4884.5	35.8	3.0	38.8	74.0	-35.2	Peak	Vertical
	7332.5	37.3	11.4	48.7	74.0	-25.3	Peak	Vertical
	11463.5	31.2	17.4	48.6	74.0	-25.4	Peak	Vertical
2470MHz	4944.0	36.2	3.2	39.4	74.0	-34.6	Peak	Horizontal
	7477.0	32.8	12.1	44.9	74.0	-29.1	Peak	Horizontal
	11582.5	32.0	17.4	49.4	74.0	-24.6	Peak	Horizontal
	4791.0	32.3	3.1	35.4	74.0	-38.6	Peak	Vertical
	7434.5	32.3	11.9	44.2	74.0	-29.8	Peak	Vertical
	11565.5	32.3	17.6	49.9	74.0	-24.1	Peak	Vertical

Note: Measure Level (dB μ V/m) = Reading Level (dB μ V) + Factor (dB/m)

Factor (dB/m) = Cable Loss (dB) + Antenna Factor (dB/m) - Pre_Amplifier Gain (dB)

The Result of Radiated Emission 30MHz~1GHz:

Site: WZ-AC1	Test Date: 2023-09-26
Limit: FCC_Part15.209_RSE(3m)	Engineer: Carl Jiang
Probe: VULB 9168_25-2000MHz	Polarity: Horizontal
EUT: Video&Data transmission device	Power: AC 120V/60Hz
Test Mode: Transmit at 2444MHz with Ant 1	

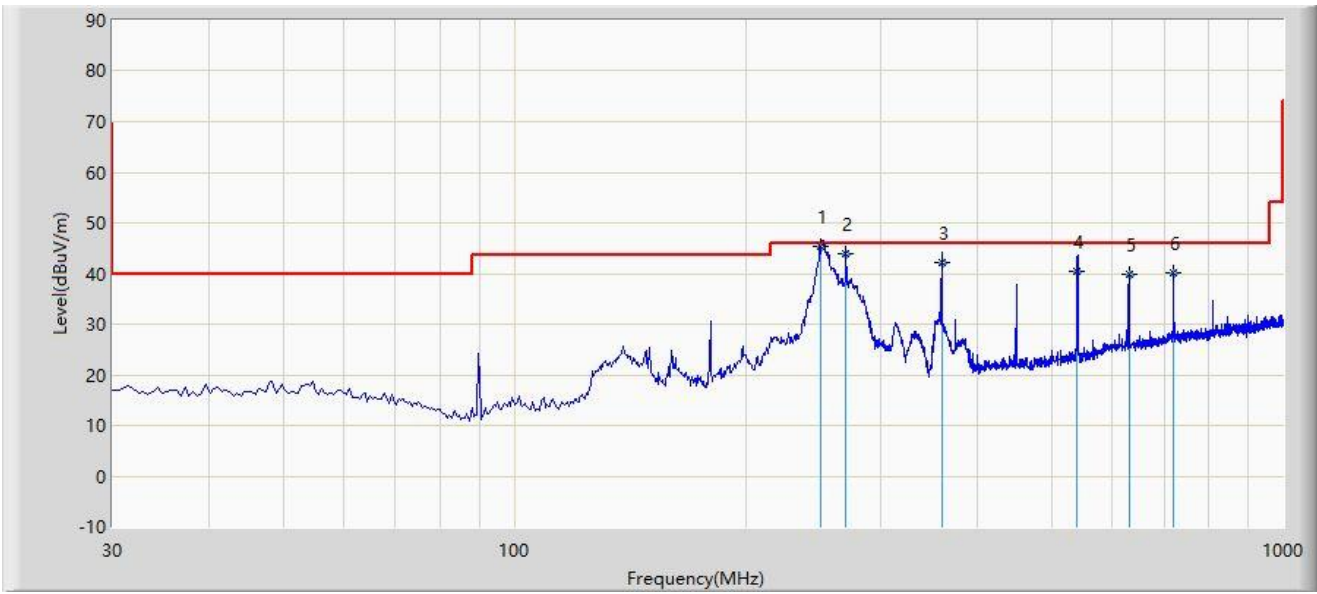

No	Mark	Frequency (MHz)	Measure Level (dBμV/m)	Reading Level (dBμV)	Margin (dB)	Limit (dBμV/m)	Factor (dB/m)	Type
1	*	250.010	45.466	28.700	-0.534	46.000	16.766	QP
2		270.000	43.787	26.200	-2.213	46.000	17.587	QP
3		360.000	42.064	22.200	-3.936	46.000	19.864	QP
4		540.000	40.572	16.500	-5.428	46.000	24.072	QP
5		629.970	39.811	13.800	-6.189	46.000	26.011	QP
6		720.000	40.048	13.000	-5.952	46.000	27.049	QP

Note 1: " * ", means this data is the worst emission level.

Note 2: Measure Level (dBμV/m) = Reading Level (dBμV) + Factor (dB/m).

Note 3: Factor (dB/m) = Cable Loss (dB) + Antenna Factor (dB/m).

Note 4: The amplitude of radiated emissions (frequency range from 9kHz to 30MHz and 18GHz to 25GHz) is that proximity to ambient noise, which also are attenuated more than 20 dB below the permissible value.

Therefore, the data is not presented in the report.

Site: WZ-AC1	Test Date: 2023-09-26
Limit: FCC_Part15.209_RSE(3m)	Engineer: Carl Jiang
Probe: VULB 9168_25-2000MHz	Polarity: Vertical
EUT: Video&Data transmission device	Power: AC 120V/60Hz
Test Mode: Transmit at 2444MHz with Ant 1	



No	Mark	Frequency (MHz)	Measure Level (dB μ V/m)	Reading Level (dB μ V)	Margin (dB)	Limit (dB μ V/m)	Factor (dB/m)	Type
1		140.010	34.845	17.100	-8.655	43.500	17.745	QP
2		180.000	34.496	17.600	-9.004	43.500	16.896	QP
3		250.000	33.066	16.300	-12.934	46.000	16.766	QP
4		270.000	38.687	21.100	-7.313	46.000	17.587	QP
5	*	540.000	40.072	16.000	-5.928	46.000	24.072	QP
6		630.040	37.412	11.400	-8.588	46.000	26.012	QP

Note 1: " * ", means this data is the worst emission level.

Note 2: Measure Level (dB μ V/m) = Reading Level (dB μ V) + Factor (dB/m).

Note 3: Factor (dB/m) = Cable Loss (dB) + Antenna Factor (dB/m).

Note 4: The amplitude of radiated emissions (frequency range from 9kHz to 30MHz and 18GHz to 25GHz) is that proximity to ambient noise, which also are attenuated more than 20 dB below the permissible value.

Therefore, the data is not presented in the report.

A.7 Radiated Restricted Band Edge Test Result

Site: WZ-AC2	Test Date: 2023-09-27
Limit: FCC_2.4G_RE(3m)	Engineer: Dick Shen
Probe: BBHA9120D_1457_1-18GHz	Polarity: Horizontal
EUT: Video&Data transmission device	Power: AC 120V/60Hz
Test Mode: Transmit at 2417MHz with Ant 0	

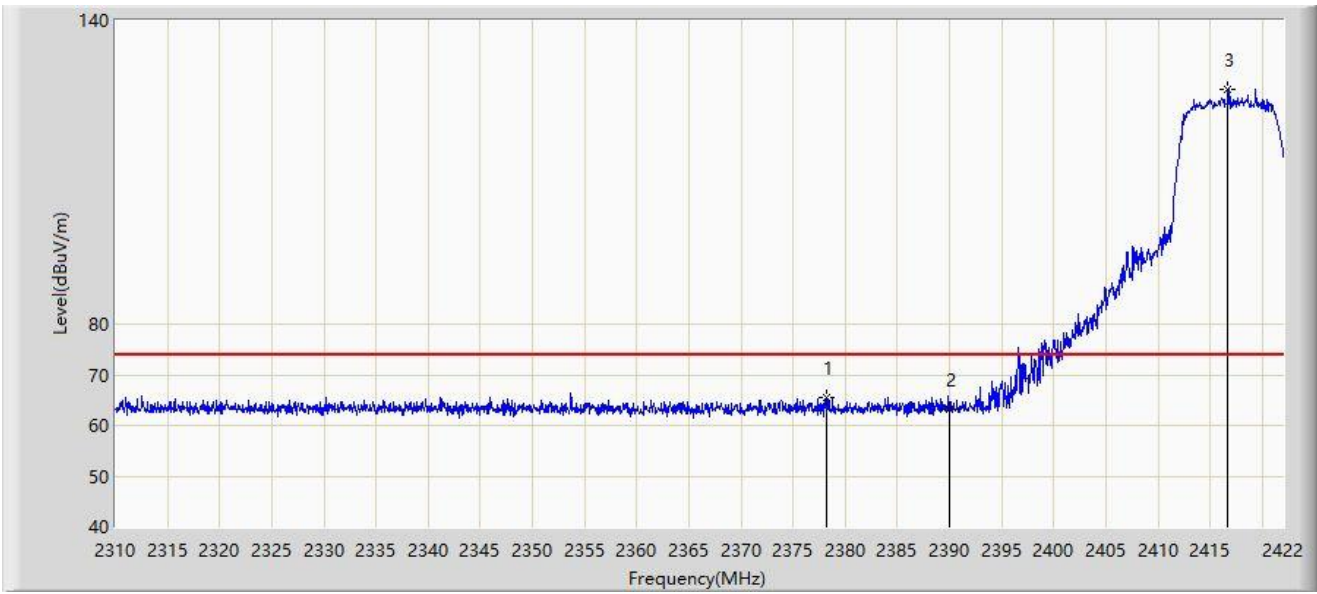

No	Mark	Frequency (MHz)	Measure Level (dB μ V/m)	Reading Level (dB μ V)	Margin (dB)	Limit (dB μ V/m)	Factor (dB/m)	Type
1	*	2378.208	65.639	33.727	-8.361	74.000	31.912	PK
2		2390.000	63.221	31.351	-10.779	74.000	31.870	PK
3		2416.736	126.365	94.589	N/A	N/A	31.775	PK

Note 1: " * ", means this data is the worst emission level.

Note 2: Measure Level (dB μ V/m) = Reading Level (dB μ V) + Factor (dB/m).

Note 3: Factor (dB/m) = Cable Loss (dB) + Antenna Factor (dB/m).

Site: WZ-AC2	Test Date: 2023-09-27
Limit: FCC_2.4G_RE(3m)	Engineer: Dick Shen
Probe: BBHA9120D_1457_1-18GHz	Polarity: Horizontal
EUT: Video&Data transmission device	Power: AC 120V/60Hz
Test Mode: Transmit at 2417MHz with Ant 0	

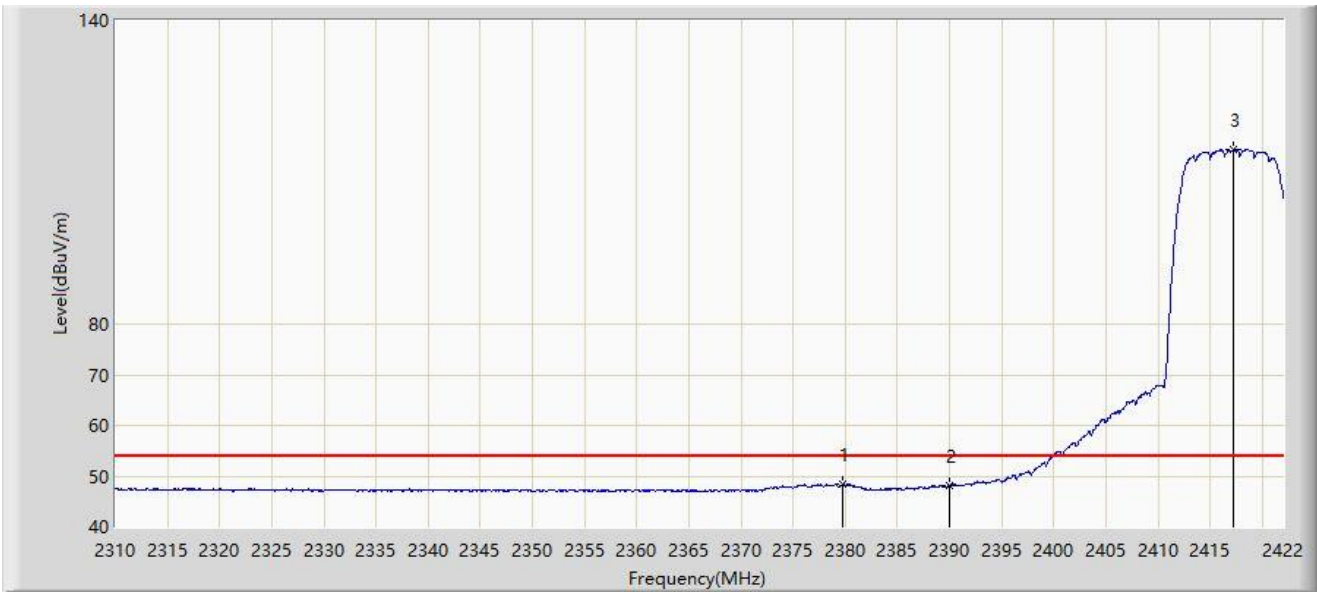

No	Mark	Frequency (MHz)	Measure Level (dB μ V/m)	Reading Level (dB μ V)	Margin (dB)	Limit (dB μ V/m)	Factor (dB/m)	Type
1	*	2379.776	48.285	16.376	-5.715	54.000	31.910	AV
2		2390.000	47.999	16.129	-6.001	54.000	31.870	AV
3		2417.296	114.383	82.609	N/A	N/A	31.774	AV

Note 1: " * ", means this data is the worst emission level.

Note 2: Measure Level (dB μ V/m) = Reading Level (dB μ V) + Factor (dB/m).

Note 3: Factor (dB/m) = Cable Loss (dB) + Antenna Factor (dB/m).

Site: WZ-AC2	Test Date: 2023-09-27
Limit: FCC_2.4G_RE(3m)	Engineer: Dick Shen
Probe: BBHA9120D_1457_1-18GHz	Polarity: Vertical
EUT: Video&Data transmission device	Power: AC 120V/60Hz
Test Mode: Transmit at 2417MHz with Ant 0	

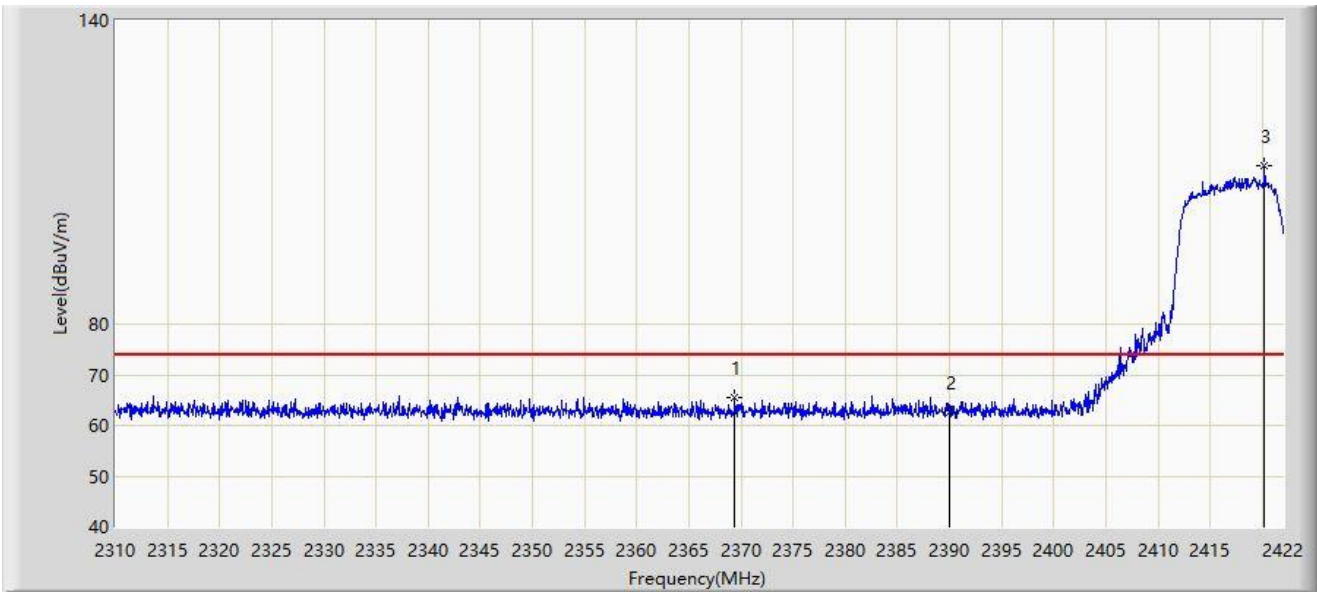

No	Mark	Frequency (MHz)	Measure Level (dB μ V/m)	Reading Level (dB μ V)	Margin (dB)	Limit (dB μ V/m)	Factor (dB/m)	Type
1	*	2369.416	65.383	33.453	-8.617	74.000	31.930	PK
2		2390.000	62.542	30.672	-11.458	74.000	31.870	PK
3		2420.208	111.267	79.499	N/A	N/A	31.767	PK

Note 1: " * ", means this data is the worst emission level.

Note 2: Measure Level (dB μ V/m) = Reading Level (dB μ V) + Factor (dB/m).

Note 3: Factor (dB/m) = Cable Loss (dB) + Antenna Factor (dB/m).

Site: WZ-AC2	Test Date: 2023-09-27
Limit: FCC_2.4G_RE(3m)	Engineer: Dick Shen
Probe: BBHA9120D_1457_1-18GHz	Polarity: Vertical
EUT: Video&Data transmission device	Power: AC 120V/60Hz
Test Mode: Transmit at 2417MHz with Ant 0	

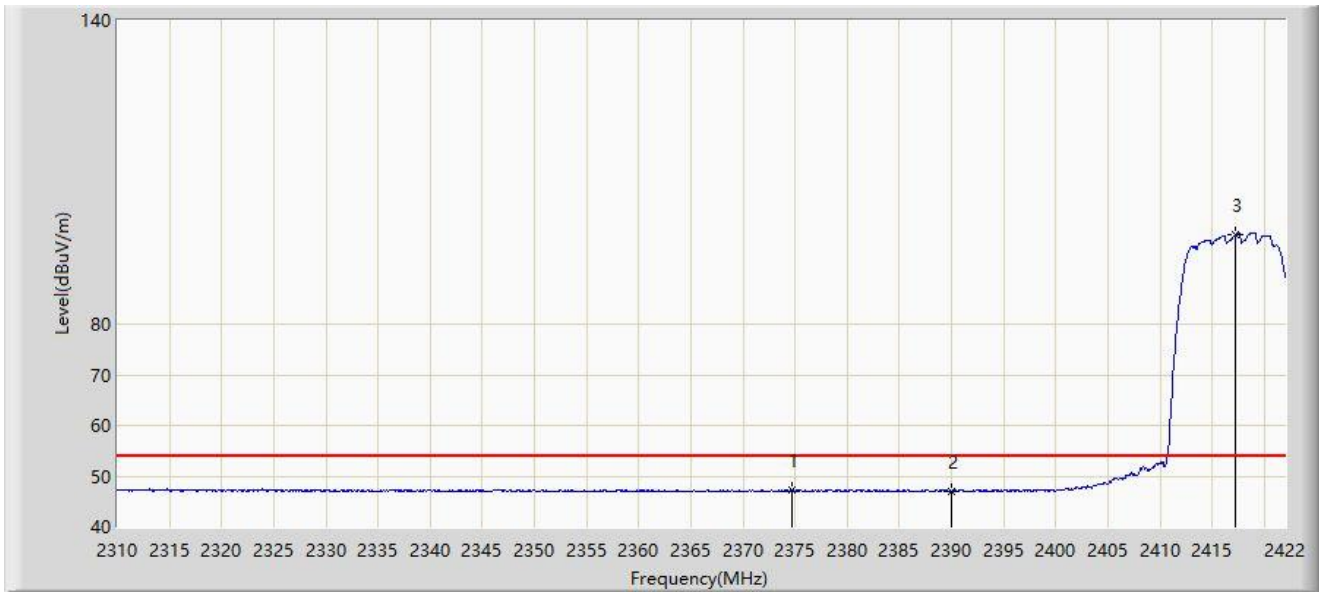

No	Mark	Frequency (MHz)	Measure Level (dBμV/m)	Reading Level (dBμV)	Margin (dB)	Limit (dBμV/m)	Factor (dB/m)	Type
1	*	2374.680	47.305	15.386	-6.695	54.000	31.918	AV
2		2390.000	47.032	15.162	-6.968	54.000	31.870	AV
3		2417.296	97.655	65.881	N/A	N/A	31.774	AV

Note 1: " * ", means this data is the worst emission level.

Note 2: Measure Level (dBμV/m) = Reading Level (dBμV) + Factor (dB/m).

Note 3: Factor (dB/m) = Cable Loss (dB) + Antenna Factor (dB/m).

Site: WZ-AC1	Test Date: 2023-09-13
Limit: FCC_2.4G_RE(3m)	Engineer: Carl Jiang
Probe: BBHA9120D_1167_1-18GHz	Polarity: Horizontal
EUT: Video&Data transmission device	Power: AC 120V/60Hz
Test Mode: Transmit at 2470MHz with Ant 0	

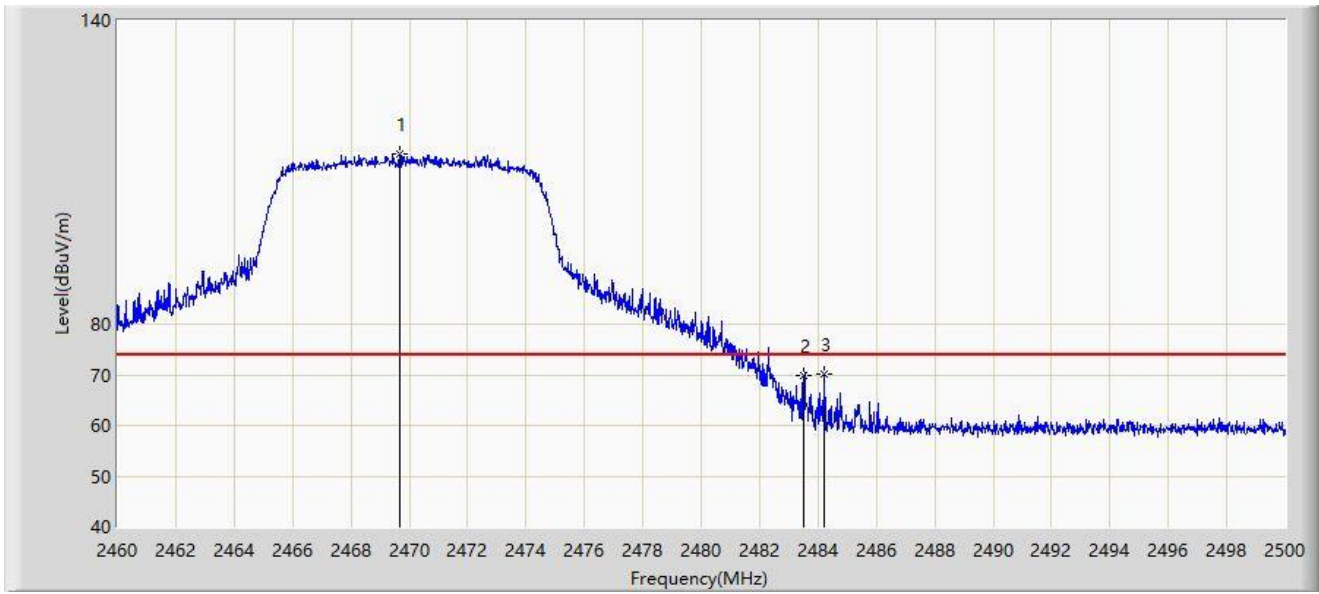

No	Mark	Frequency (MHz)	Measure Level (dB μ V/m)	Reading Level (dB μ V)	Margin (dB)	Limit (dB μ V/m)	Factor (dB/m)	Type
1		2469.660	113.701	82.478	N/A	N/A	31.222	PK
2		2483.500	69.777	38.551	-4.223	74.000	31.226	PK
3	*	2484.220	70.099	38.872	-3.901	74.000	31.227	PK

Note 1: " * ", means this data is the worst emission level.

Note 2: Measure Level (dB μ V/m) = Reading Level (dB μ V) + Factor (dB/m).

Note 3: Factor (dB/m) = Cable Loss (dB) + Antenna Factor (dB/m).

Site: WZ-AC1	Test Date: 2023-09-13
Limit: FCC_2.4G_RE(3m)	Engineer: Carl Jiang
Probe: BBHA9120D_1167_1-18GHz	Polarity: Horizontal
EUT: Video&Data transmission device	Power: AC 120V/60Hz
Test Mode: Transmit at 2470MHz with Ant 0	

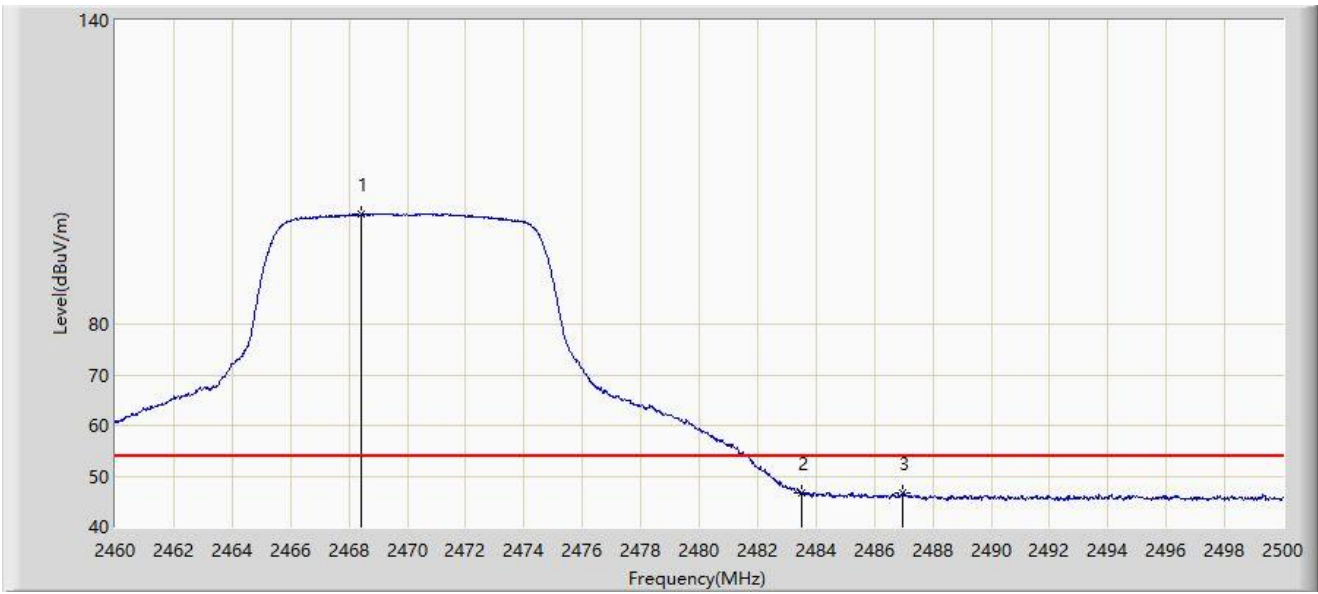

No	Mark	Frequency (MHz)	Measure Level (dB μ V/m)	Reading Level (dB μ V)	Margin (dB)	Limit (dB μ V/m)	Factor (dB/m)	Type
1		2468.440	101.655	70.432	N/A	N/A	31.223	AV
2	*	2483.500	46.682	15.456	-7.318	54.000	31.226	AV
3		2486.980	46.662	15.433	-7.338	54.000	31.229	AV

Note 1: " * ", means this data is the worst emission level.

Note 2: Measure Level (dB μ V/m) = Reading Level (dB μ V) + Factor (dB/m).

Note 3: Factor (dB/m) = Cable Loss (dB) + Antenna Factor (dB/m).

Site: WZ-AC1	Test Date: 2023-09-13
Limit: FCC_2.4G_RE(3m)	Engineer: Carl Jiang
Probe: BBHA9120D_1167_1-18GHz	Polarity: Vertical
EUT: Video&Data transmission device	Power: AC 120V/60Hz
Test Mode: Transmit at 2470MHz with Ant 0	

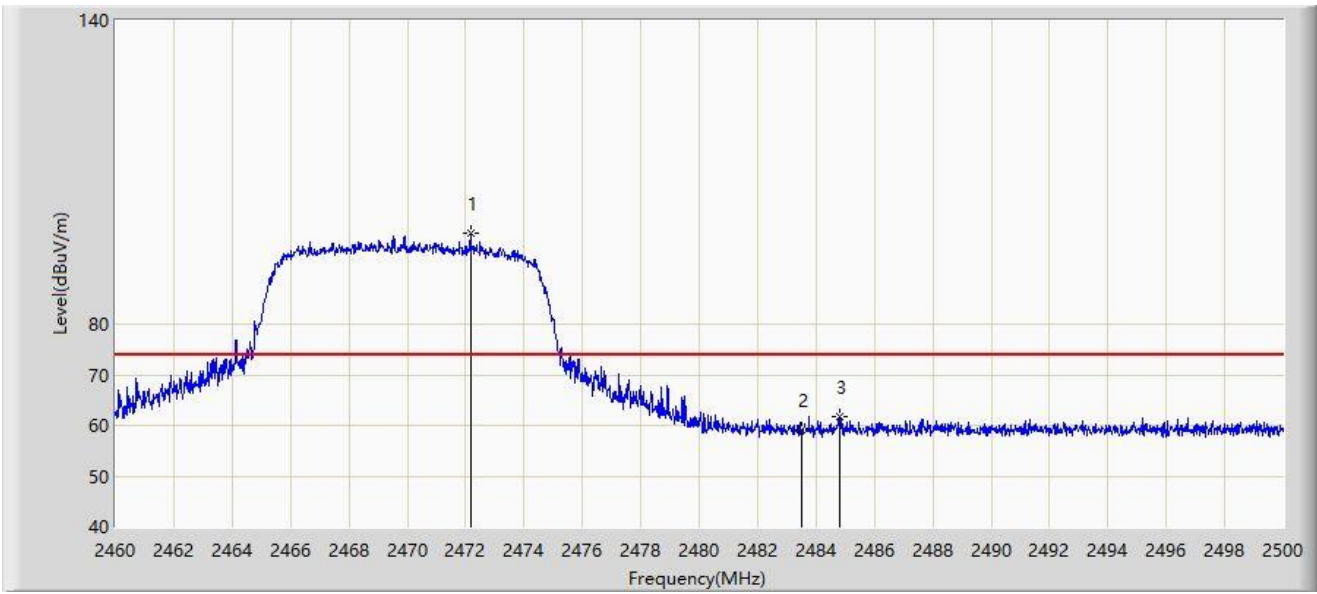

No	Mark	Frequency (MHz)	Measure Level (dBμV/m)	Reading Level (dBμV)	Margin (dB)	Limit (dBμV/m)	Factor (dB/m)	Type
1		2472.160	97.998	66.776	N/A	N/A	31.222	PK
2		2483.500	59.023	27.797	-14.977	74.000	31.226	PK
3	*	2484.820	61.803	30.576	-12.197	74.000	31.227	PK

Note 1: " * ", means this data is the worst emission level.

Note 2: Measure Level (dBμV/m) = Reading Level (dBμV) + Factor (dB/m).

Note 3: Factor (dB/m) = Cable Loss (dB) + Antenna Factor (dB/m).

Site: WZ-AC1	Test Date: 2023-09-13
Limit: FCC_2.4G_RE(3m)	Engineer: Carl Jiang
Probe: BBHA9120D_1167_1-18GHz	Polarity: Vertical
EUT: Video&Data transmission device	Power: AC 120V/60Hz
Test Mode: Transmit at 2470MHz with Ant 0	

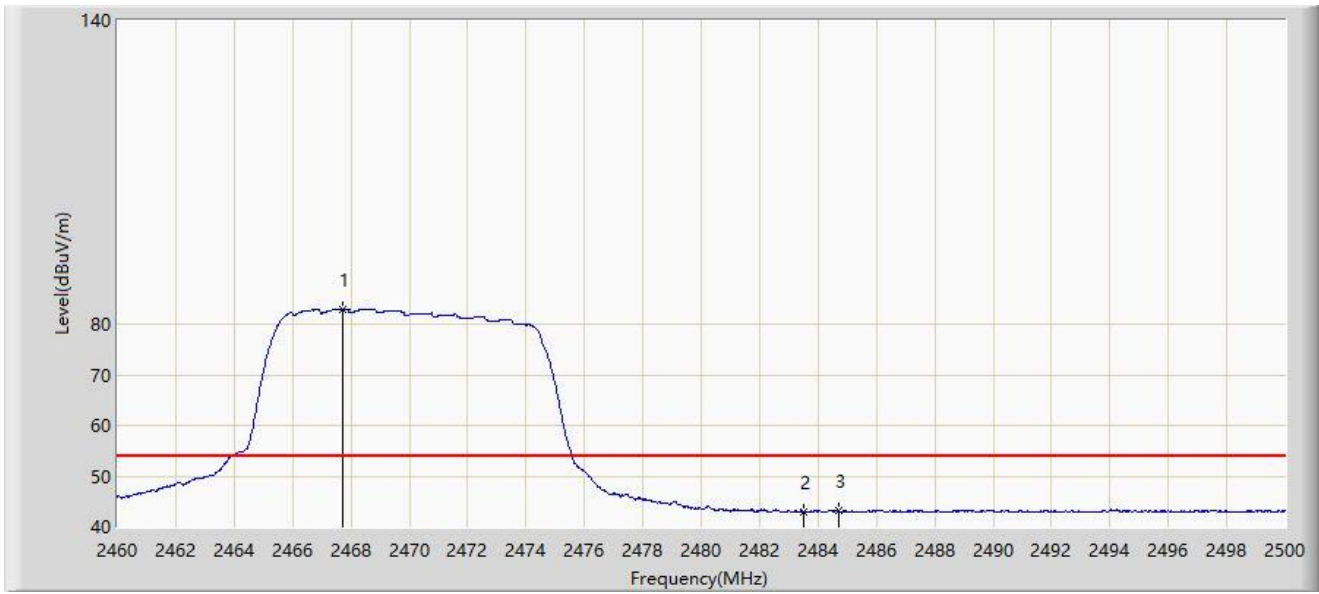

No	Mark	Frequency (MHz)	Measure Level (dB μ V/m)	Reading Level (dB μ V)	Margin (dB)	Limit (dB μ V/m)	Factor (dB/m)	Type
1		2467.720	83.015	51.792	N/A	N/A	31.223	AV
2		2483.500	42.915	11.689	-11.085	54.000	31.226	AV
3	*	2484.700	43.263	12.036	-10.737	54.000	31.227	AV

Note 1: " * ", means this data is the worst emission level.

Note 2: Measure Level (dB μ V/m) = Reading Level (dB μ V) + Factor (dB/m).

Note 3: Factor (dB/m) = Cable Loss (dB) + Antenna Factor (dB/m).

Site: WZ-AC2	Test Date: 2023-09-27
Limit: FCC_2.4G_RE(3m)	Engineer: Dick Shen
Probe: BBHA9120D_1457_1-18GHz	Polarity: Horizontal
EUT: Video&Data transmission device	Power: AC 120V/60Hz
Test Mode: Transmit at 2417MHz with Ant 1	

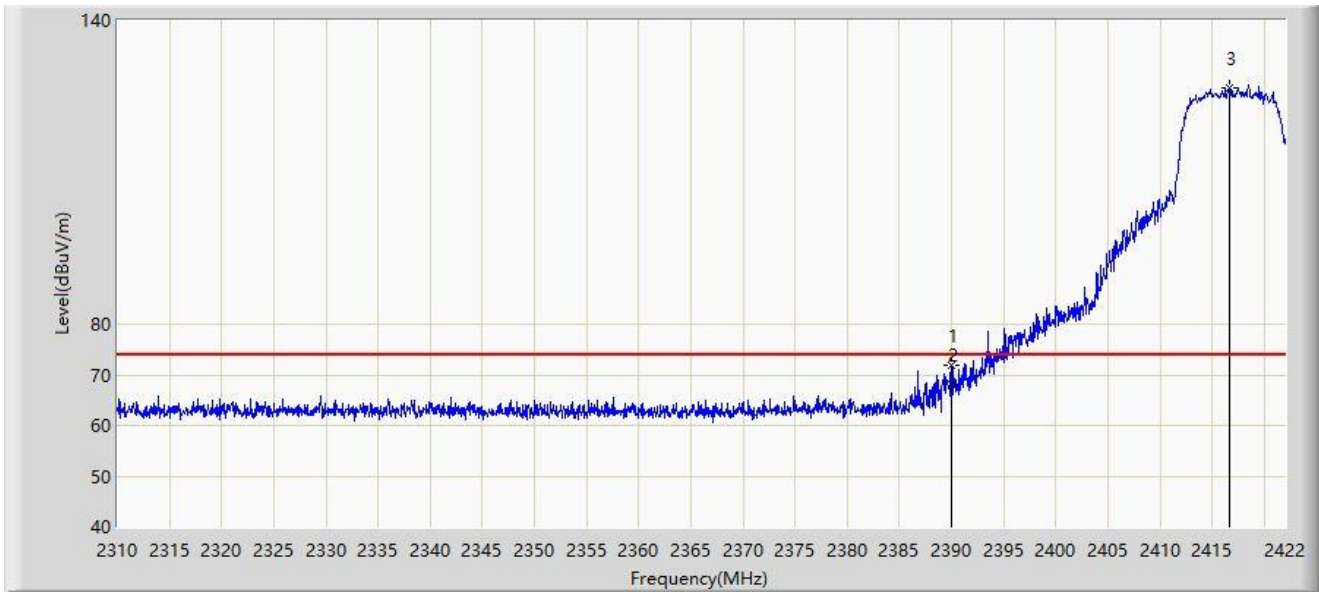

No	Mark	Frequency (MHz)	Measure Level (dB μ V/m)	Reading Level (dB μ V)	Margin (dB)	Limit (dB μ V/m)	Factor (dB/m)	Type
1	*	2389.968	71.813	39.943	-2.187	74.000	31.870	PK
2		2390.000	68.060	36.190	-5.940	74.000	31.870	PK
3		2416.736	126.544	94.768	N/A	N/A	31.775	PK

Note 1: " * ", means this data is the worst emission level.

Note 2: Measure Level (dB μ V/m) = Reading Level (dB μ V) + Factor (dB/m).

Note 3: Factor (dB/m) = Cable Loss (dB) + Antenna Factor (dB/m).

Site: WZ-AC2	Test Date: 2023-09-27
Limit: FCC_2.4G_RE(3m)	Engineer: Dick Shen
Probe: BBHA9120D_1457_1-18GHz	Polarity: Horizontal
EUT: Video&Data transmission device	Power: AC 120V/60Hz
Test Mode: Transmit at 2417MHz with Ant 1	

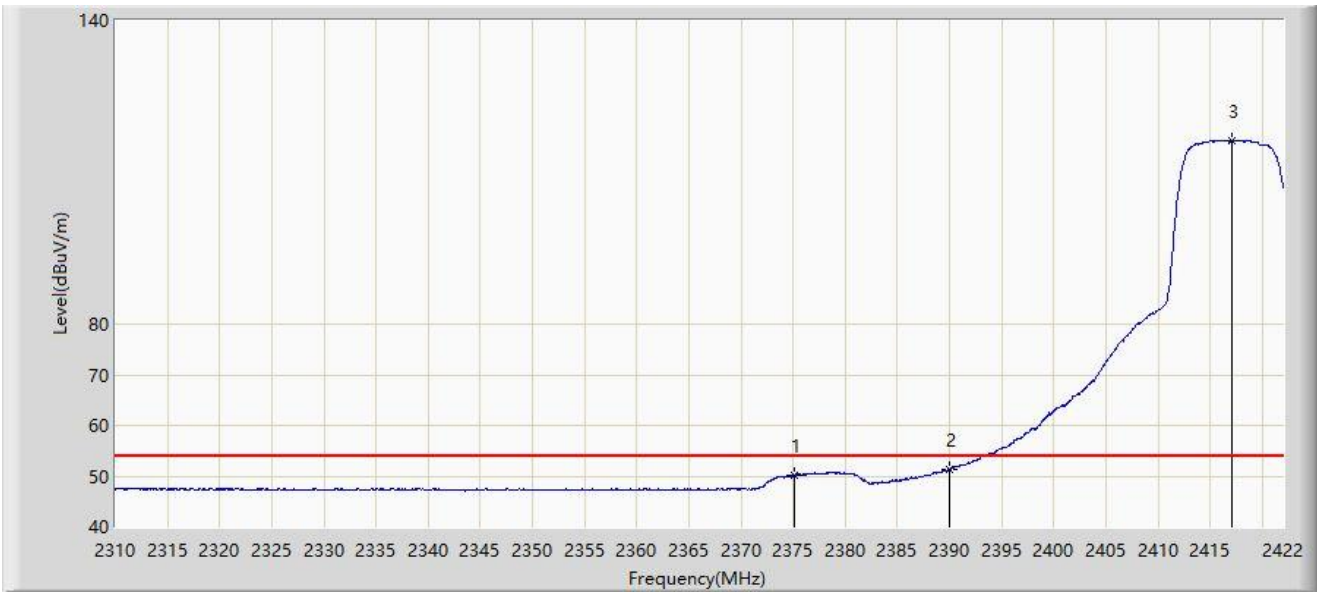

No	Mark	Frequency (MHz)	Measure Level (dBμV/m)	Reading Level (dBμV)	Margin (dB)	Limit (dBμV/m)	Factor (dB/m)	Type
1		2375.128	50.112	18.194	-3.888	54.000	31.918	AV
2	*	2390.000	51.306	19.436	-2.694	54.000	31.870	AV
3		2417.128	116.261	84.486	N/A	N/A	31.774	AV

Note 1: " * ", means this data is the worst emission level.

Note 2: Measure Level (dBμV/m) = Reading Level (dBμV) + Factor (dB/m).

Note 3: Factor (dB/m) = Cable Loss (dB) + Antenna Factor (dB/m).

Site: WZ-AC2	Test Date: 2023-09-27
Limit: FCC_2.4G_RE(3m)	Engineer: Dick Shen
Probe: BBHA9120D_1457_1-18GHz	Polarity: Vertical
EUT: Video&Data transmission device	Power: AC 120V/60Hz
Test Mode: Transmit at 2417MHz with Ant 1	

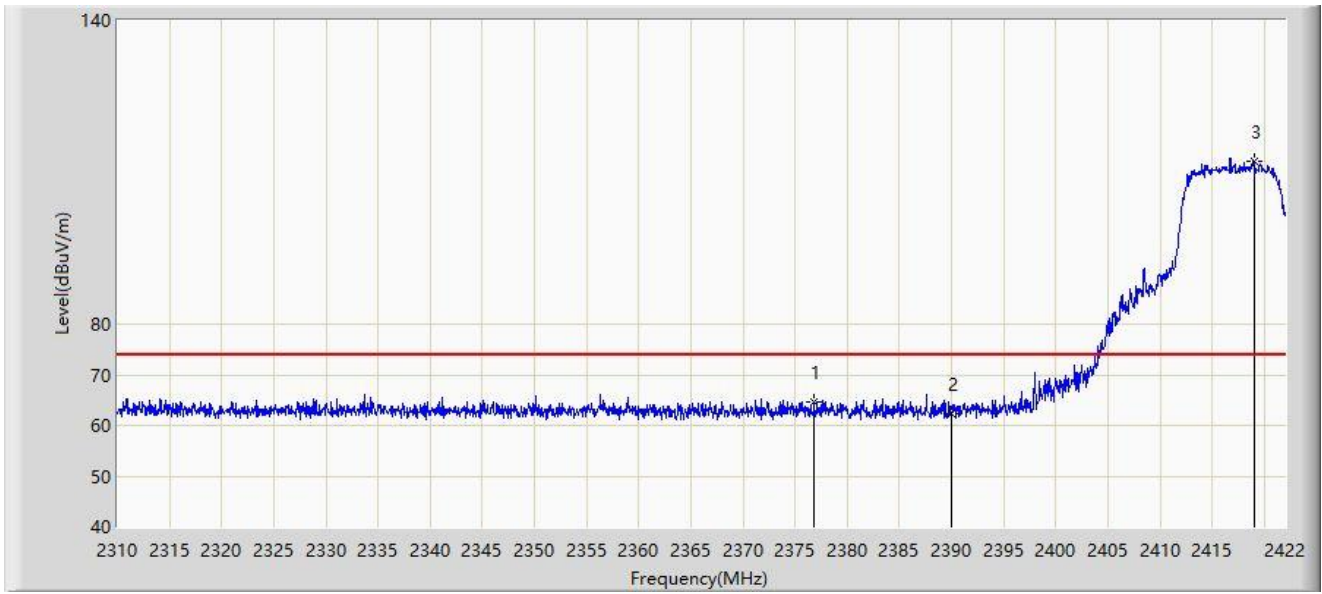

No	Mark	Frequency (MHz)	Measure Level (dB μ V/m)	Reading Level (dB μ V)	Margin (dB)	Limit (dB μ V/m)	Factor (dB/m)	Type
1	*	2376.808	64.717	32.803	-9.283	74.000	31.914	PK
2		2390.000	62.443	30.573	-11.557	74.000	31.870	PK
3		2419.032	112.232	80.462	N/A	N/A	31.770	PK

Note 1: " * ", means this data is the worst emission level.

Note 2: Measure Level (dB μ V/m) = Reading Level (dB μ V) + Factor (dB/m).

Note 3: Factor (dB/m) = Cable Loss (dB) + Antenna Factor (dB/m).

Site: WZ-AC2	Test Date: 2023-09-27
Limit: FCC_2.4G_RE(3m)	Engineer: Dick Shen
Probe: BBHA9120D_1457_1-18GHz	Polarity: Vertical
EUT: Video&Data transmission device	Power: AC 120V/60Hz
Test Mode: Transmit at 2417MHz with Ant 1	

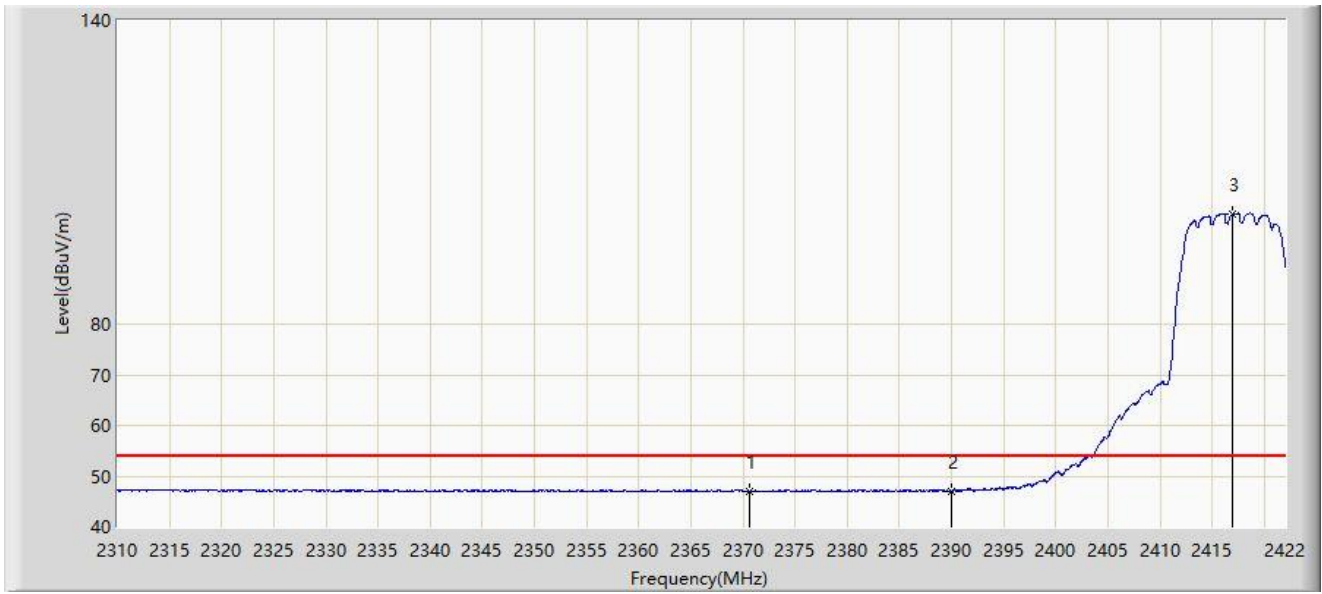

No	Mark	Frequency (MHz)	Measure Level (dB μ V/m)	Reading Level (dB μ V)	Margin (dB)	Limit (dB μ V/m)	Factor (dB/m)	Type
1		2370.648	46.990	15.063	-7.010	54.000	31.928	AV
2	*	2390.000	47.012	15.142	-6.988	54.000	31.870	AV
3		2417.016	101.657	69.882	N/A	N/A	31.775	AV

Note 1: " * ", means this data is the worst emission level.

Note 2: Measure Level (dB μ V/m) = Reading Level (dB μ V) + Factor (dB/m).

Note 3: Factor (dB/m) = Cable Loss (dB) + Antenna Factor (dB/m).

Site: WZ-AC1	Test Date: 2023-09-13
Limit: FCC_2.4G_RE(3m)	Engineer: Carl Jiang
Probe: BBHA9120D_1167_1-18GHz	Polarity: Horizontal
EUT: Video&Data transmission device	Power: AC 120V/60Hz
Test Mode: Transmit at 2470MHz with Ant 1	

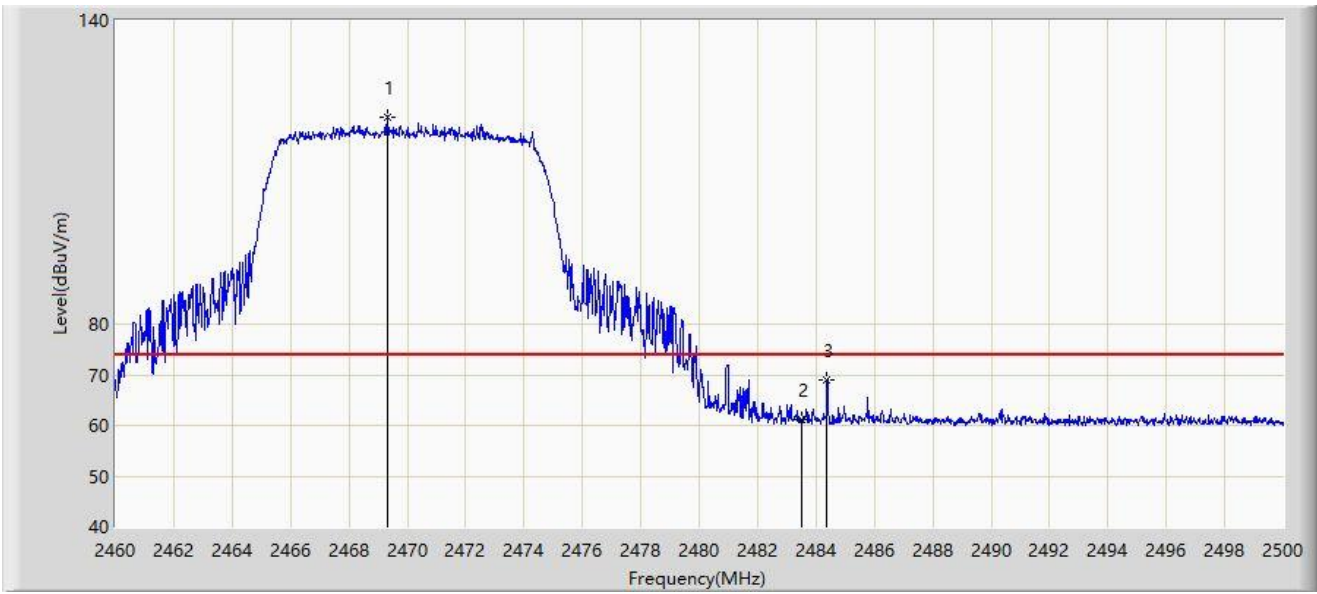

No	Mark	Frequency (MHz)	Measure Level (dB μ V/m)	Reading Level (dB μ V)	Margin (dB)	Limit (dB μ V/m)	Factor (dB/m)	Type
1		2469.300	121.014	89.791	N/A	N/A	31.223	PK
2		2483.500	61.230	30.004	-12.770	74.000	31.226	PK
3	*	2484.380	69.076	37.849	-4.924	74.000	31.227	PK

Note 1: " * ", means this data is the worst emission level.

Note 2: Measure Level (dB μ V/m) = Reading Level (dB μ V) + Factor (dB/m).

Note 3: Factor (dB/m) = Cable Loss (dB) + Antenna Factor (dB/m).

Site: WZ-AC1	Test Date: 2023-09-13
Limit: FCC_2.4G_RE(3m)	Engineer: Carl Jiang
Probe: BBHA9120D_1167_1-18GHz	Polarity: Horizontal
EUT: Video&Data transmission device	Power: AC 120V/60Hz
Test Mode: Transmit at 2470MHz with Ant 1	

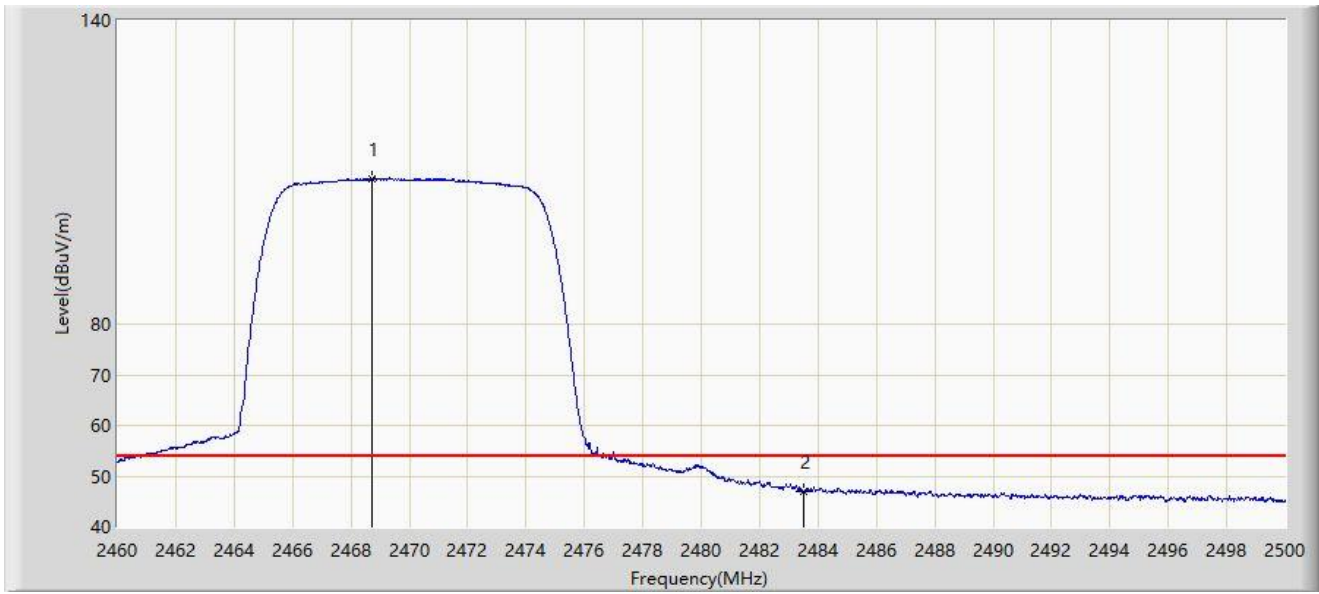

No	Mark	Frequency (MHz)	Measure Level (dB μ V/m)	Reading Level (dB μ V)	Margin (dB)	Limit (dB μ V/m)	Factor (dB/m)	Type
1		2468.700	108.791	77.568	N/A	N/A	31.223	AV
2	*	2483.500	46.909	15.683	-7.091	54.000	31.226	AV

Note 1: " * ", means this data is the worst emission level.

Note 2: Measure Level (dB μ V/m) = Reading Level (dB μ V) + Factor (dB/m).

Note 3: Factor (dB/m) = Cable Loss (dB) + Antenna Factor (dB/m).

Site: WZ-AC1	Test Date: 2023-09-13
Limit: FCC_2.4G_RE(3m)	Engineer: Carl Jiang
Probe: BBHA9120D_1167_1-18GHz	Polarity: Vertical
EUT: Video&Data transmission device	Power: AC 120V/60Hz
Test Mode: Transmit at 2470MHz with Ant 1	

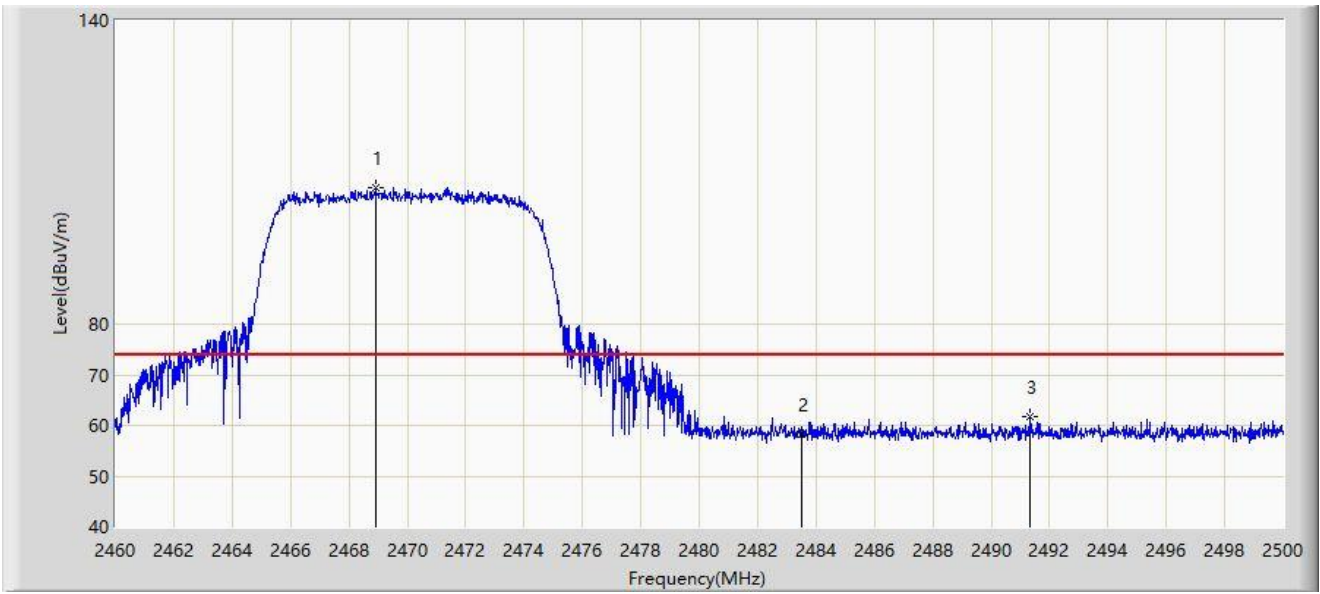

No	Mark	Frequency (MHz)	Measure Level (dB μ V/m)	Reading Level (dB μ V)	Margin (dB)	Limit (dB μ V/m)	Factor (dB/m)	Type
1		2468.900	106.996	75.773	N/A	N/A	31.223	PK
2		2483.500	58.264	27.038	-15.736	74.000	31.226	PK
3	*	2491.320	61.756	30.524	-12.244	74.000	31.232	PK

Note 1: " * ", means this data is the worst emission level.

Note 2: Measure Level (dB μ V/m) = Reading Level (dB μ V) + Factor (dB/m).

Note 3: Factor (dB/m) = Cable Loss (dB) + Antenna Factor (dB/m).

Site: WZ-AC1	Test Date: 2023-09-13
Limit: FCC_2.4G_RE(3m)	Engineer: Carl Jiang
Probe: BBHA9120D_1167_1-18GHz	Polarity: Vertical
EUT: Video&Data transmission device	Power: AC 120V/60Hz
Test Mode: Transmit at 2470MHz with Ant 1	

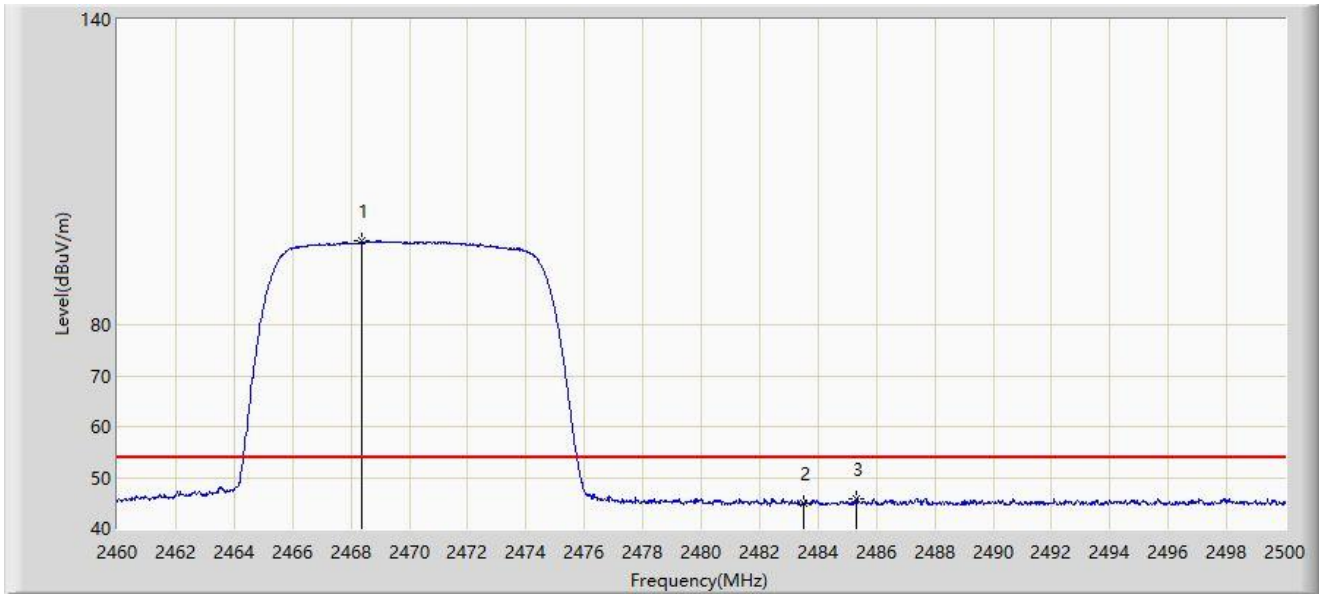

No	Mark	Frequency (MHz)	Measure Level (dB μ V/m)	Reading Level (dB μ V)	Margin (dB)	Limit (dB μ V/m)	Factor (dB/m)	Type
1		2468.360	96.434	65.211	N/A	N/A	31.223	AV
2		2483.500	44.913	13.687	-9.087	54.000	31.226	AV
3	*	2485.320	45.749	14.521	-8.251	54.000	31.228	AV

Note 1: " * ", means this data is the worst emission level.

Note 2: Measure Level (dB μ V/m) = Reading Level (dB μ V) + Factor (dB/m).

Note 3: Factor (dB/m) = Cable Loss (dB) + Antenna Factor (dB/m).

Appendix B – Test Setup Photograph

Refer to “2308RSU079-UT” file.

Appendix C – EUT Photograph

Refer to “2308RSU079-UE” file.

————— The End —————