



FCC AND ISED CERTIFICATION TEST REPORT

Applicant	:	Globe Electric Company Inc.
Address of Applicant	:	150 Oneida, Montreal, Quebec, Canada, H9R 1A8
Manufacturer	:	Globe Electric Company Inc.
Address of Manufacturer	:	150 Oneida, Montreal, Quebec, Canada, H9R 1A8
Equipment under Test	:	A19 LED bulb
Model No.	:	50589*
FCC ID	:	2AQUQGB50589
IC	:	8290A-GB50589
Test Standard(s)	:	FCC Rules and Regulations Part 15 Subpart C, RSS-247 Issue 3 August 2023, ANSI C63.10:2013, RSS-Gen Issue 5, Apr. 2018, Amendment 2 (February 2021)
Report No.	:	DDT-RE24060702-2E01
Issue Date	:	2024/07/11
Issue By	:	Guangdong Dongdian Testing Service Co., Ltd. Unit 2, Building 1, No. 17, Zongbu 2nd Road, Songshan Lake Park, Dongguan, Guangdong, China, 523808

Table of Contents

1.	Summary of Test Results	7
2.	General Test Information.....	8
2.1.	Description of EUT.....	8
2.2.	Accessories of EUT	8
2.3.	Block diagram of EUT configuration for test.....	9
2.4.	Decision of final test mode	9
2.5.	Deviations of test standard	9
2.6.	Test environment conditions.....	10
2.7.	Test laboratory	10
2.8.	Measurement uncertainty	11
3.	Equipment Used During Conductive Test.....	12
4.	6dB Bandwidth.....	13
4.1.	Block diagram of test setup	13
4.2.	Limits.....	13
4.3.	Test procedure.....	13
4.4.	Test result	14
4.5.	Test graphs.....	15
5.	99% Bandwidth.....	19
5.1.	Block diagram of test setup	19
5.2.	Limits.....	19
5.3.	Test procedure.....	19
5.4.	Test result	20
5.5.	Test graphs.....	21
6.	Conducted Output Power	25
6.1.	Block diagram of test setup	25
6.2.	Limits.....	25
6.3.	Test procedure.....	25
6.4.	Test result average	26
7.	Power Spectral Density	27
7.1.	Block diagram of test setup	27
7.2.	Limits.....	27
7.3.	Test procedure.....	27
7.4.	Test result	28
7.5.	Test graphs.....	29
8.	Band Edge Compliance (Conducted Method).....	33
8.1.	Block diagram of test setup	33

8.2.	Limits.....	33
8.3.	Test procedure.....	33
8.4.	Test result	34
8.5.	Test graphs.....	35
9.	RF Conducted Spurious Emissions.....	38
9.1.	Block diagram of test setup	38
9.2.	Limits.....	38
9.3.	Test procedure.....	38
9.4.	Test result	39
9.5.	Test graphs.....	40
10.	Duty Cycle.....	52
10.1.	Block diagram of test setup	52
10.2.	Limit.....	52
10.3.	Test procedure.....	52
10.4.	Test result	53
10.5.	Test graphs.....	54
11.	Antenna Requirements.....	58
11.1.	Limit.....	58
11.2.	Result.....	58
12.	Radiated Emission.....	59
12.1.	Test equipment	59
12.2.	Block diagram of test setup	60
12.3.	Limits.....	61
12.4.	Assistant equipment used for test	63
12.5.	Test procedure.....	63
12.6.	Test result	64
12.7.	Test data	65
13.	Band Edge Compliance.....	73
13.1.	Test equipment	73
13.2.	Block diagram of test setup	74
13.3.	Limits.....	74
13.4.	Assistant equipment used for test	74
13.5.	Test procedure.....	74
13.6.	Test result	74
13.7.	Test data	75
14.	Power Line Conducted Emissions.....	91
14.1.	Test equipment	91
14.2.	Block diagram of test setup	91

14.3.	Limits.....	91
14.4.	Assistant equipment used for test	91
14.5.	Test procedure.....	92
14.6.	Test result	92
14.7.	Test data	93
15.	Test Setup Photograph.....	95
16.	Photos of the EUT	97

Test Report Declare

Applicant	:	Globe Electric Company Inc.
Address of Applicant	:	150 Oneida, Montreal, Quebec, Canada, H9R 1A8
Equipment under Test	:	A19 LED bulb
Model No.	:	50589*
Manufacturer	:	Globe Electric Company Inc.
Address of Manufacturer	:	150 Oneida, Montreal, Quebec, Canada, H9R 1A8

Test Standard Used:

FCC Rules and Regulations Part 15 Subpart C,
 RSS-247 Issue 3 August 2023,
 ANSI C63.10:2013,
 RSS-Gen Issue 5, Apr. 2018, Amendment 2 (February 2021)

We Declare:

The equipment described above is tested by Guangdong Dongdian Testing Service Co., Ltd. and in the configuration tested the equipment complied with the standards specified above. The test results are contained in this test report and Guangdong Dongdian Testing Service Co., Ltd. is assumed of full responsibility for the accuracy and completeness of these tests.

Report No.:	DDT-RE24060702-2E01		
Date of Receipt:	2024/06/12	Date of Test:	2024/06/12~2024/07/11

Prepared By:

Johnson Huang

Johnson Huang/Engineer

Approved By:

Damon Hu

Damon Hu/EMC Manager

Note: This report applies to above tested sample only. This report shall not be reproduced in parts without written approval of Guangdong Dongdian Testing Service Co., Ltd.

Revision History

Rev.	Revisions	Issue Date	Revised By
---	Initial issue	2024/07/11	

1. Summary of Test Results

No.	Test Parameter	Clause No.	Condition	Result
1	6 dB Bandwidth and 99% Bandwidth	FCC Part 15: 15.247(a)(2), RSS-247 Issue 3 clause 5.2(a), RSS-Gen Issue 5 clause 6.7	/	Pass
2	Peak Output Power	FCC Part 15: 15.247(b)(3), RSS-247 Issue 3 clause 5.4(d)	/	Pass
3	Power Spectral Density	FCC Part 15:15.247(e), RSS-247 Issue 3 clause 5.2(b)	/	Pass
4	RF Conducted Spurious Emissions	FCC Part 15: 15.247(d), RSS-247 Issue 3 clause 5.5	/	Pass
5	Radiated Emission	FCC Part 15: 15.205, FCC Part 15: 15.209, FCC Part 15: 15.247(d), RSS-247 Issue 3 clause 5.5, RSS-Gen Issue 5 clause 8.9, RSS-Gen Issue 5 clause 8.10	/	Pass
6	Band Edge Compliance	FCC Part 15: 15.205, FCC Part 15: 15.209, FCC Part 15: 15.247(d), RSS-247 Issue 3 clause 5.5, RSS-Gen Issue 5 clause 8.9, RSS-Gen Issue 5 clause 8.10	/	Pass
7	Antenna Requirement	FCC Part 15: 15.203, RSS-Gen Issue 5 clause 6.8	/	Pass
8	Power Line Conducted Emissions	FCC Part 15: 15.207(a), RSS-Gen Issue 5 clause 8.8	/	Pass

Note: N/A is an abbreviation for Not Applicable, and means this item is not applicable for this device or no need to test according to standard.

2. General Test Information

2.1. Description of EUT

EUT Name	: A19 LED bulb
Model Number	: 50589*
EUT Function Description	: Please reference user manual of this device
Power Supply	: AC120V/60Hz

Note: This EUT support Bluetooth LE, 2.4 GHz WLAN, this report only for 2.4 GHz WLAN.

Radio Technology	: IEEE 802.11b/g/n
Operation frequency	: IEEE 802.11b: 2412MHz-2462MHz IEEE 802.11g: 2412MHz-2462MHz IEEE 802.11n HT20: 2412MHz-2462MHz IEEE 802.11n HT40: 2422MHz-2452MHz
Modulation	: IEEE 802.11b: DSSS (CCK, DQPSK, DBPSK) IEEE 802.11g: OFDM (64QAM, 16QAM, QPSK, BPSK) IEEE 802.11n: OFDM (64QAM, 16QAM, QPSK, BPSK)

Antenna information		
Antenna Type	PCB	
Max Antenna Gain(dBi)	/	Ant1 gain
	IEEE 802.11b	2.87
	IEEE 802.11g	2.87
	IEEE 802.11n HT20	2.87
	IEEE 802.11n HT40	2.87

Channel information					
CH	Frequency (MHz)	CH	Frequency (MHz)	CH	Frequency (MHz)
1	2412	5	2432	9	2452
2	2417	6	2437	10	2457
3	2422	7	2442	11	2462
4	2427	8	2447	/	/

Note: The above EUT information is declared by manufacturer and for more detailed features description please refer to the manufacturer's specifications or User's Manual. The above Antenna information is declared by manufacturer and for more detailed features description please refer to the manufacturer's specifications, the laboratory shall not be held responsible.

“☑” means to be chosen or applicable; “☐” means don't to be chosen or not applicable; This note applies to entire report.

2.2. Accessories of EUT

Accessories	Manufacturer	Model number	Description
/	/	/	/

2.3. Block diagram of EUT configuration for test

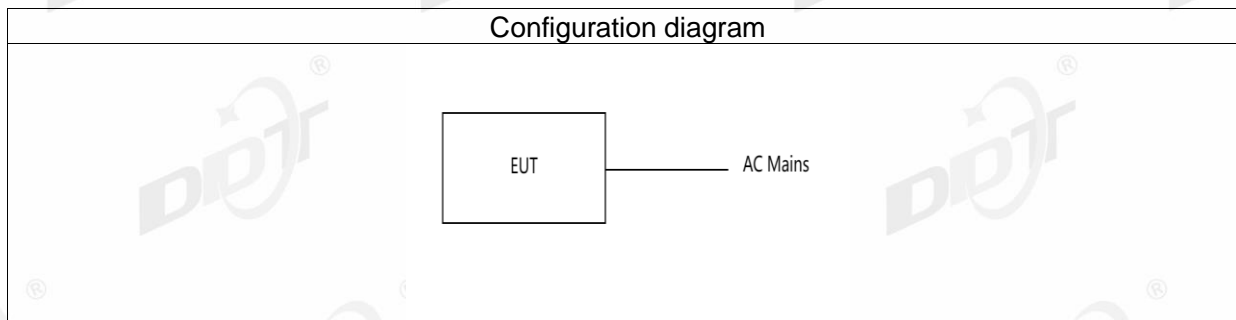

2.4. Decision of final test mode

According pre-test, the worst test modes were reported as below:

Test software: EspRFTestTool_v3.6_Manual

The test software was used to control EUT work in Continuous Tx mode and select test channel, wireless mode as below table.

The pathloss of external cable: 0.5dB (According to the manufacturer's claims)

Tested mode, channel, and data rate information					
Mode	Setting Tx Power		Data rate (Mbps) (see Note)	Channel	Frequency (MHz)
	ANT1	ANT2			
IEEE 802.11b	Default	Default	1	LCH: CH1	2412
	Default	Default	1	MCH: CH6	2437
	Default	Default	1	HCH: CH11	2462
IEEE 802.11g	Default	Default	6	LCH: CH1	2412
	Default	Default	6	MCH: CH6	2437
	Default	Default	6	HCH: CH11	2462
IEEE 802.11n HT20	Default	Default	MCS 0	LCH: CH1	2412
	Default	Default	MCS 0	MCH: CH6	2437
	Default	Default	MCS 0	HCH: CH11	2462
IEEE 802.11n HT40	Default	Default	MCS 0	LCH: CH3	2422
	Default	Default	MCS 0	MCH: CH6	2437
	Default	Default	MCS 0	HCH: CH9	2452

Note: According exploratory test, EUT will have maximum output power in those data rate, so those data rate were used for all test.

2.5. Deviations of test standard

No deviation.

2.6. Test environment conditions

During the measurement the environmental conditions were within the listed ranges:

Temperature range:	+15°C to +35 °C
Humidity range:	20% to 75%
Pressure range:	86 kPa to106 kPa

Note: The specific temperature and humidity information of each test item refers to the temperature and humidity record in the corresponding test data.

2.7. Test laboratory

Guangdong Dongdian Testing Service Co., Ltd.

Add.: Unit 2, Building 1, No. 17, Zongbu 2nd Road, Songshan Lake Park, Dongguan, Guangdong, China, 523808.

Tel.: +86-0769-38826678, <http://www.dgddt.com>, Email: ddt@dgddt.com.

CNAS Accreditation No. L6451; A2LA Accreditation Number: 3870.01

FCC Designation Number: CN1182, Test Firm Registration Number: 540522

Innovation, Science and Economic Development Canada Site Registration Number: 10288A

Conformity Assessment Body identifier: CN0048

VCCI facility registration number: C-20087, T-20088, R-20123, R-20155, G-20118

2.8. Measurement uncertainty

Test Item	Uncertainty
Bandwidth	1.1%
Peak Output Power (Conducted) (Spectrum analyzer)	0.86 dB (10 MHz ≤ f < 3.6 GHz);
	1.38 dB (3.6 GHz ≤ f < 8 GHz)
Peak Output Power (Conducted) (Power Sensor)	0.74 dB
Power Spectral Density	0.74 dB (10 MHz ≤ f < 3.6 GHz);
	1.38 dB (3.6 GHz ≤ f < 8 GHz)
Frequencies Stability	6.7 x 10 ⁻⁸ (Antenna couple method)
	5.5 x 10 ⁻⁸ (Conducted method)
Conducted spurious emissions	0.86 dB (10 MHz ≤ f < 3.6 GHz);
	1.40 dB (3.6 GHz ≤ f < 8 GHz)
	1.66 dB (8 GHz ≤ f < 26.5 GHz)
Uncertainty for radio frequency (RBW < 20 kHz)	3x10 ⁻⁸
Temperature	0.4 °C
Humidity	2 %
Uncertainty for Radiation Emission test (9 kHz – 30 MHz)	3.44 dB
Uncertainty for Radiation Emission test (30 MHz - 1 GHz)	4.70 dB (Antenna Polarize: V)
	4.84 dB (Antenna Polarize: H)
Uncertainty for Radiation Emission test (1 GHz - 40 GHz)	4.10 dB (1 - 6 GHz)
	4.40 dB (6 GHz - 18 GHz)
	3.54 dB (18 GHz - 26 GHz)
	4.30 dB (26 GHz - 40 GHz)
Uncertainty for Power line conduction emission test	3.34dB (150KHz-30MHz)
	3.72dB (9KHz-150KHz)

Note: This uncertainty represents an expanded uncertainty expressed at approximately the 95% confidence level using a coverage factor of k=2.

3. Equipment Used During Conductive Test

Equipment	Manufacturer	Model No.	Serial Number	Due Date
☑RF Connected Test (RF Measurement System 3#)				
SIGNAL ANALYZER	R&S	FSV40	101407	2024/07/11
Wideband Radio Communication Tester	R&S	CMW500	117491	2025/03/31
EXG Analog Signal Generator	KEYSIGHT	N5173B	MY62153058	2024/07/11
MXG Vector Signal Generator	Agilent	N5182A	MY48180912	2025/03/31
RF Control Unit	Tonscend	JS0806-2	20C8060230	2025/03/31
TEMP&HUMI Programmable Chamber	ZHIXIANG	ZXGDJS-150L	ZX170110-A	2024/05/14
Test Software	Tonscend	JS1120-3	Ver.3.2.22	N/A

4. 6dB Bandwidth

4.1. Block diagram of test setup

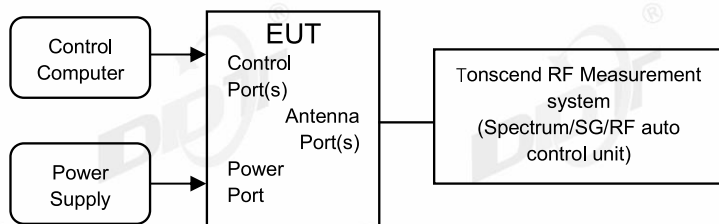

4.2. Limits

For direct sequence systems, the minimum 6 dB bandwidth shall be at least 500 kHz

4.3. Test procedure

- (1) The test according to ANSI C63.10-2013 clause 11.8.
- (2) Connect EUT's antenna output to spectrum analyzer by RF cable, the path loss was compensated to the results
- (3) Set the EUT as maximum power setting and enable the EUT transmit continuously
- (4) Use the following spectrum analyzer settings for 6 dB Bandwidth:

RBW:	100 kHz
VBW:	$\geq [3 \times \text{RBW}]$
Detector Mode:	peak
Sweep time:	auto
Trace mode	max hold

Allow the trace to stabilize, measure the 6 dB bandwidth of signal, and record the results in the report

4.4. Test result

Test Engineer:	Zhongyao	Test Site:	RF Measurement System 3#
Ambient Condition:	26.4°C,43.5%RH	Test Date:	2024.07.02
Test Power Supply:	AC 120V	Sample Number:	S24060702-002

Test Mode	Antenna	Frequency [MHz]	DTS BW [MHz]	FL [MHz]	FH [MHz]	Limit [MHz]	Verdict
11B	Ant1	2412	9.52	2407.00	2416.52	0.5	PASS
		2437	10.04	2431.96	2442.00	0.5	PASS
		2462	9.00	2457.48	2466.48	0.5	PASS
11G	Ant1	2412	16.36	2403.84	2420.20	0.5	PASS
		2437	16.32	2428.84	2445.16	0.5	PASS
		2462	16.36	2453.84	2470.20	0.5	PASS
11N20SIS O	Ant1	2412	16.68	2403.84	2420.52	0.5	PASS
		2437	16.60	2428.60	2445.20	0.5	PASS
		2462	16.80	2453.60	2470.40	0.5	PASS
11N40SIS O	Ant1	2422	35.12	2404.48	2439.60	0.5	PASS
		2437	35.36	2419.24	2454.60	0.5	PASS
		2452	35.12	2434.48	2469.60	0.5	PASS

4.5. Test graphs

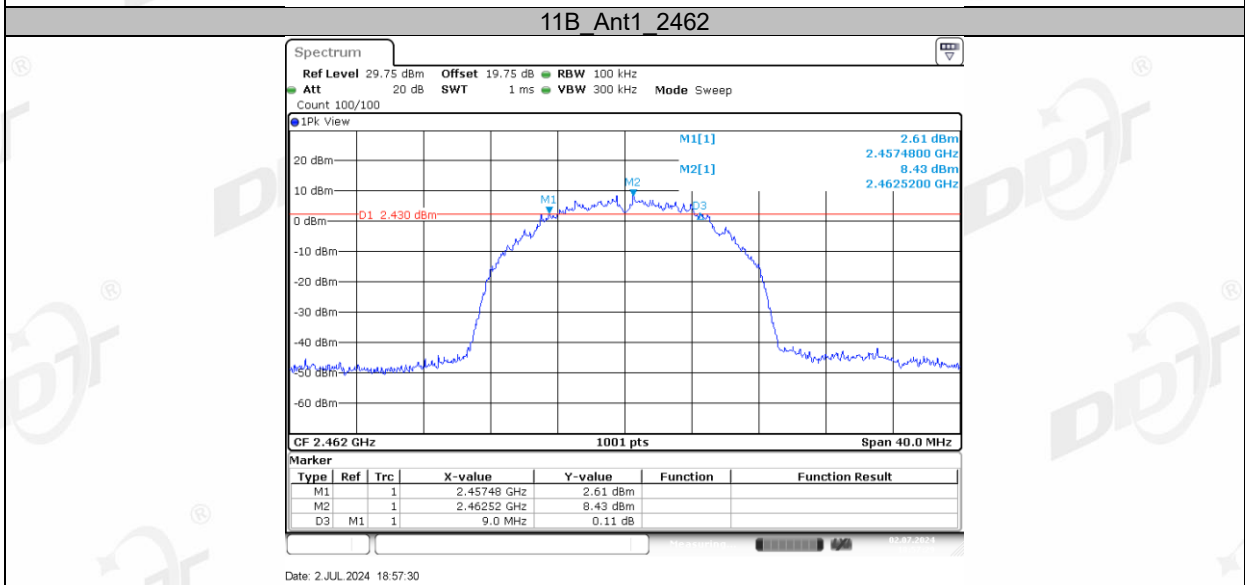
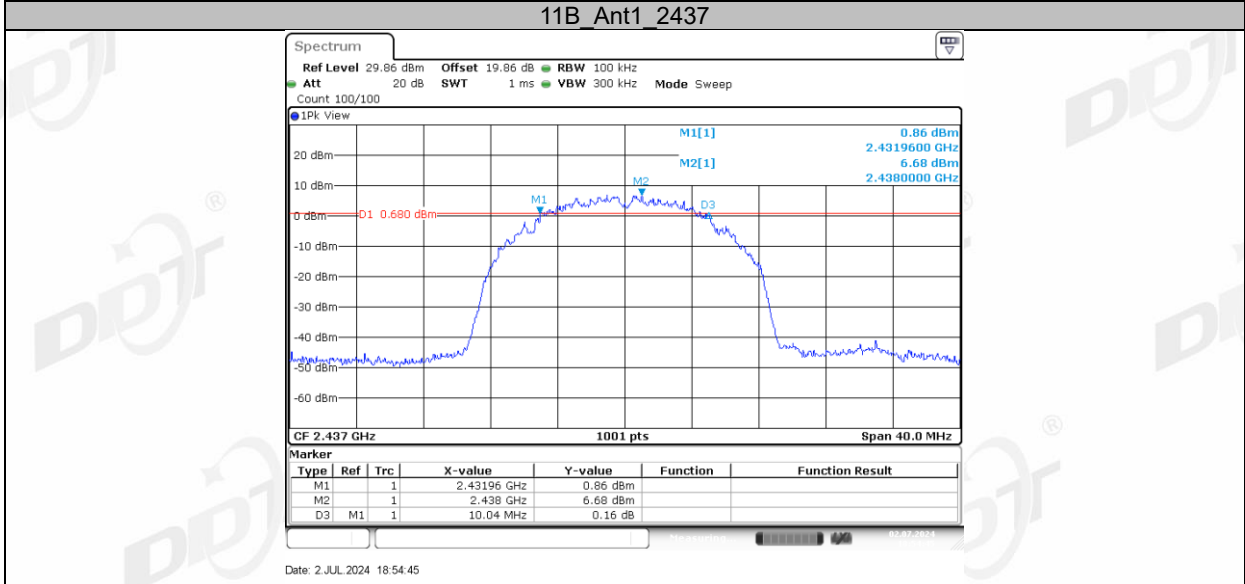
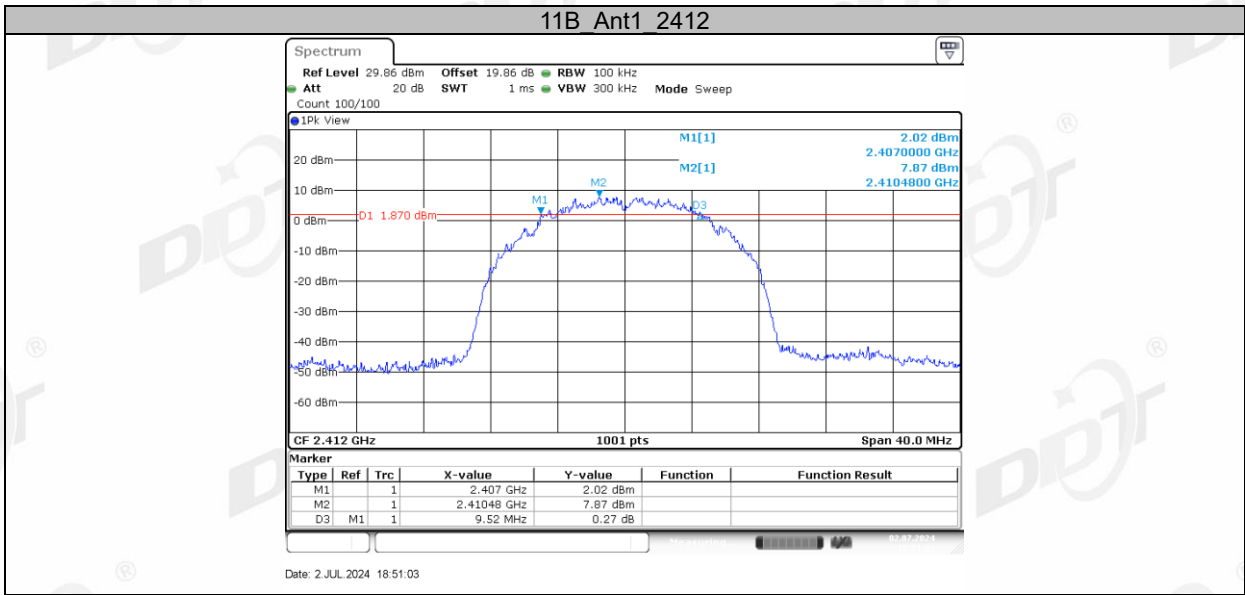

11G Ant1 2412

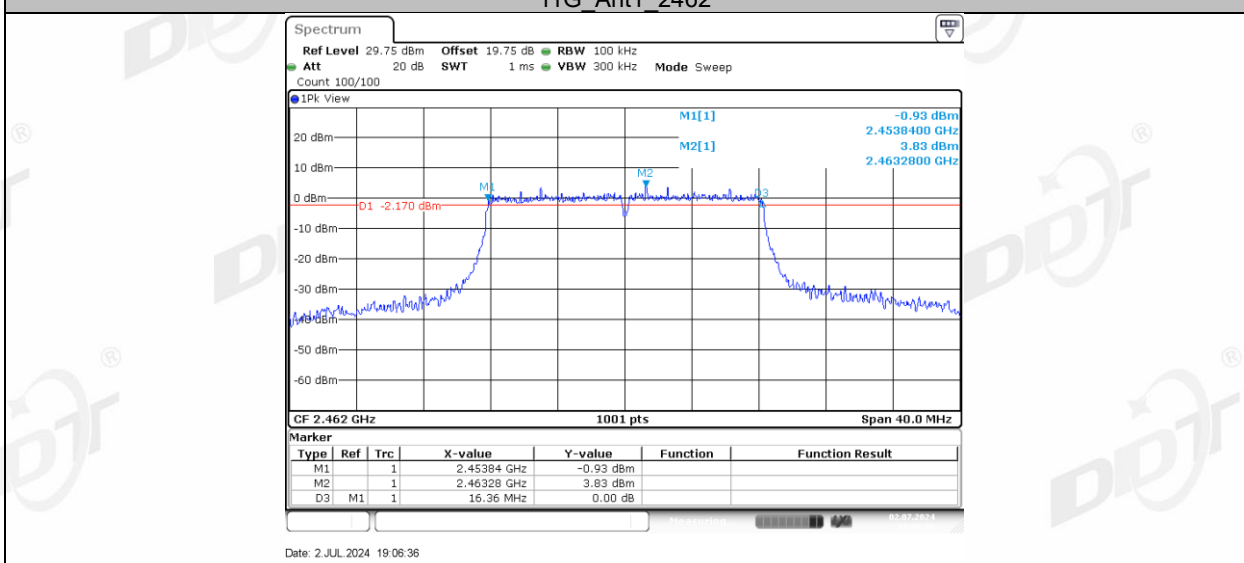
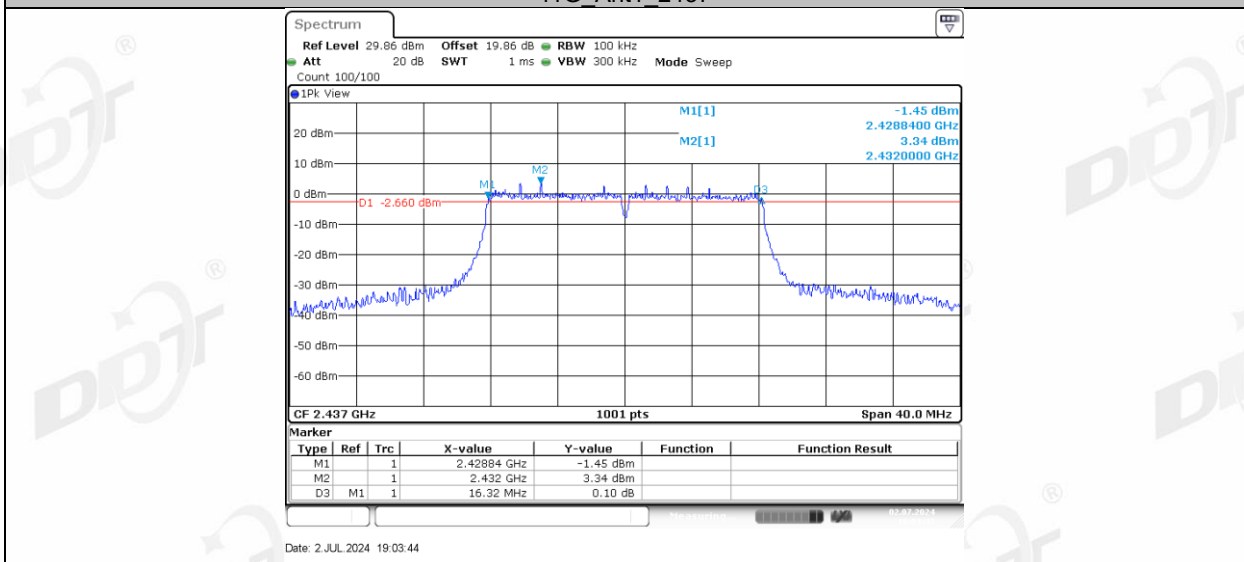
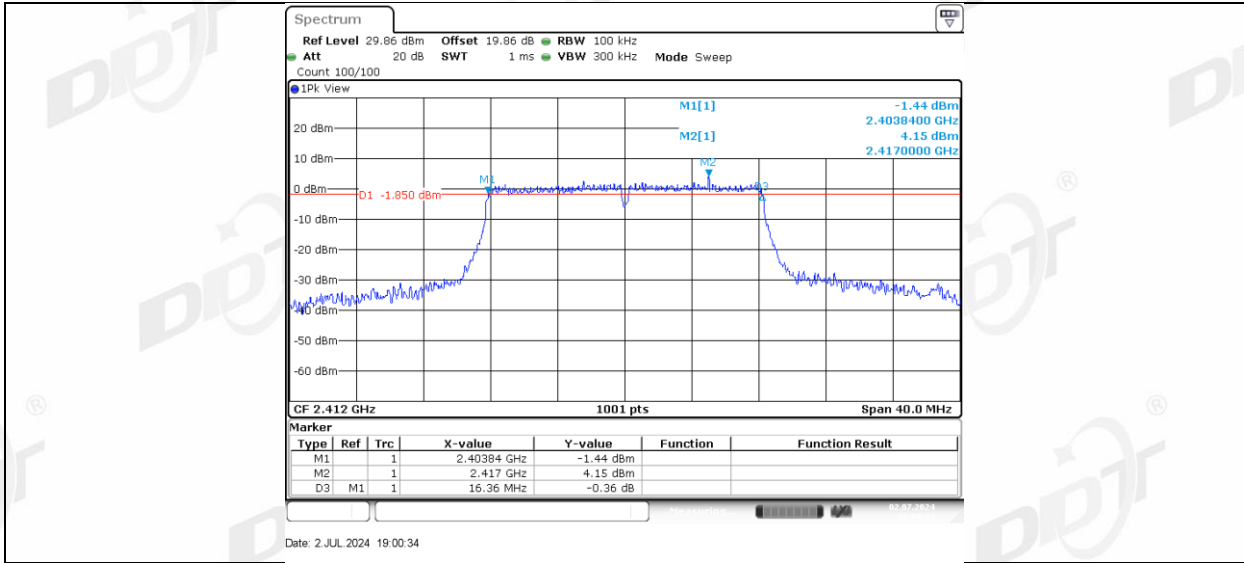

11N20SISO Ant1_2412

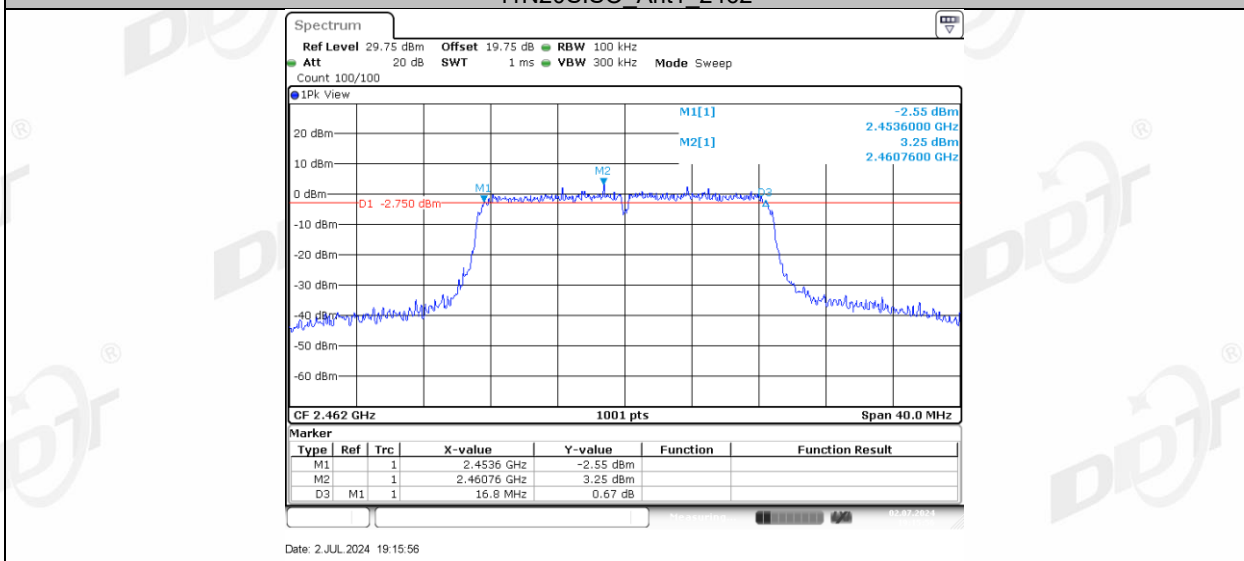
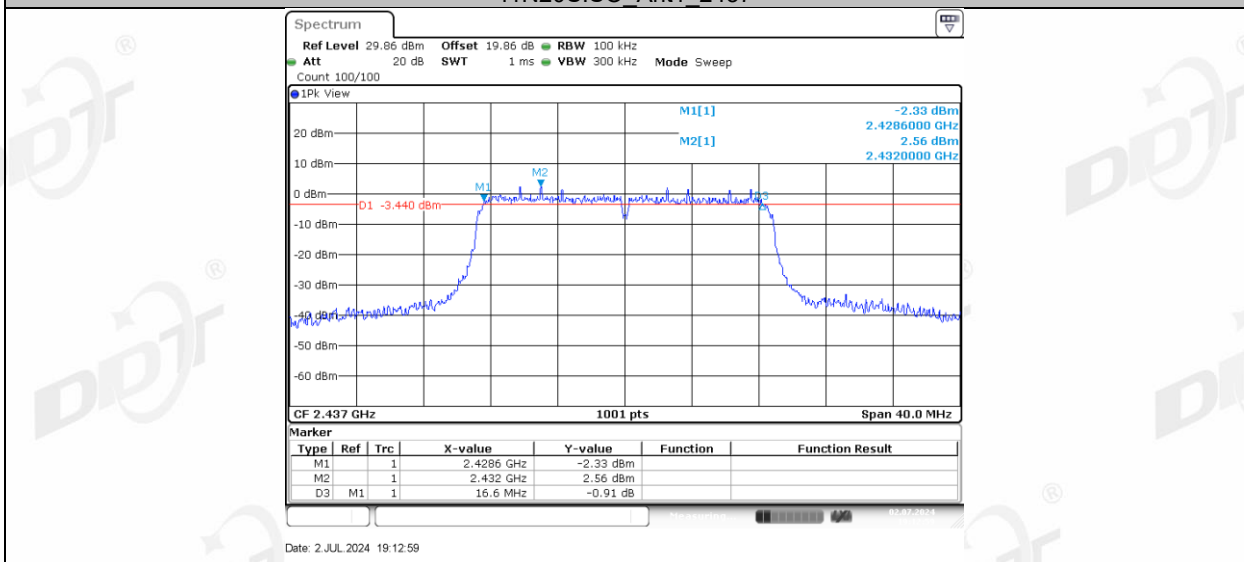
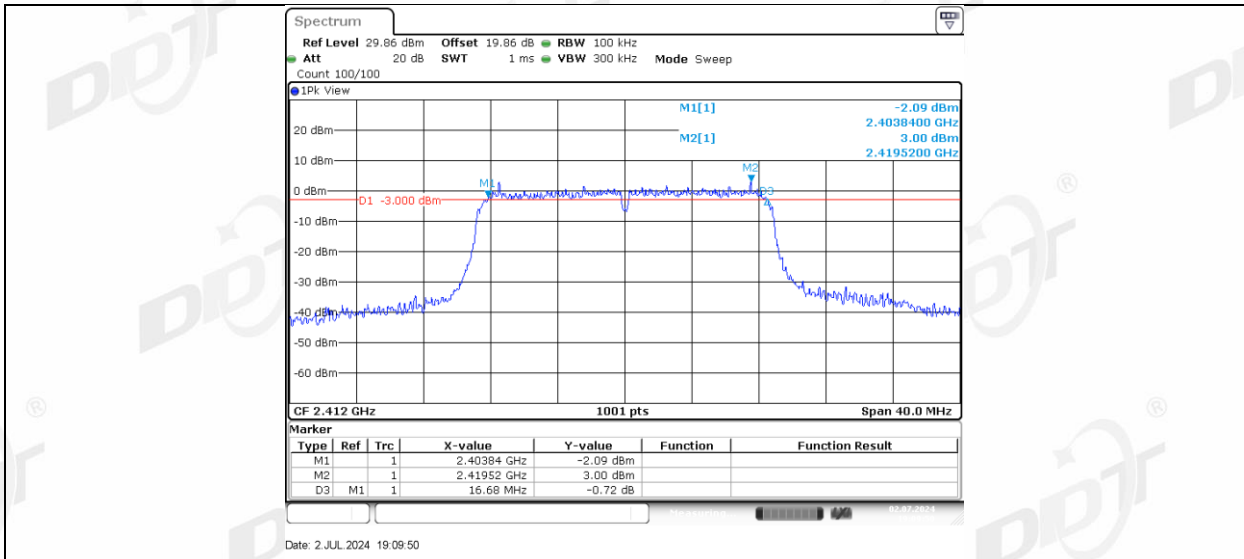

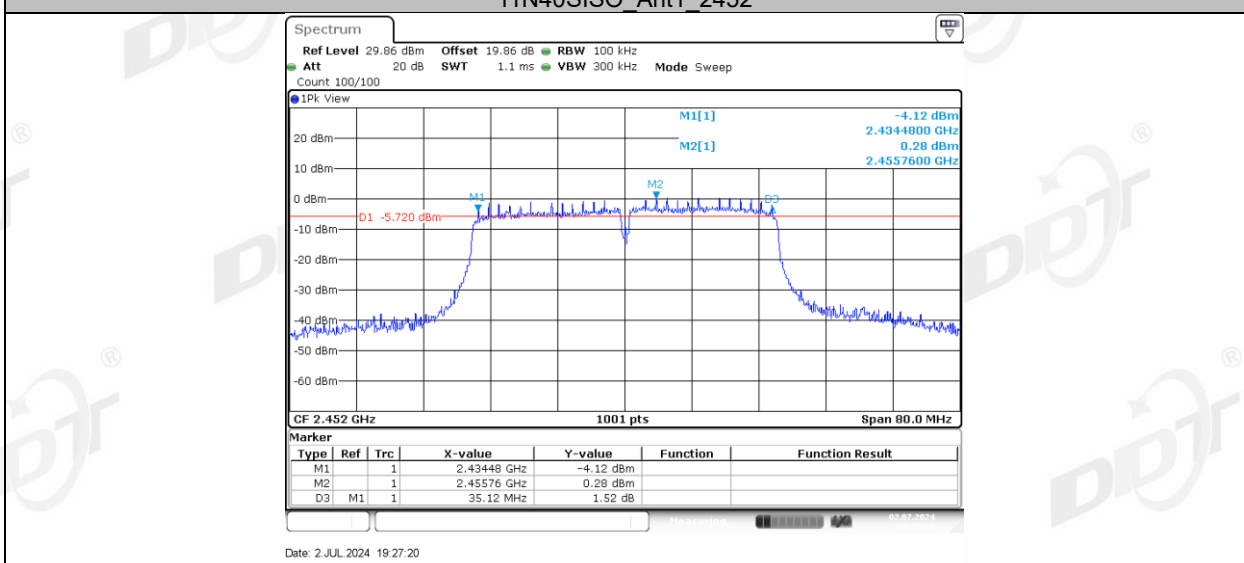
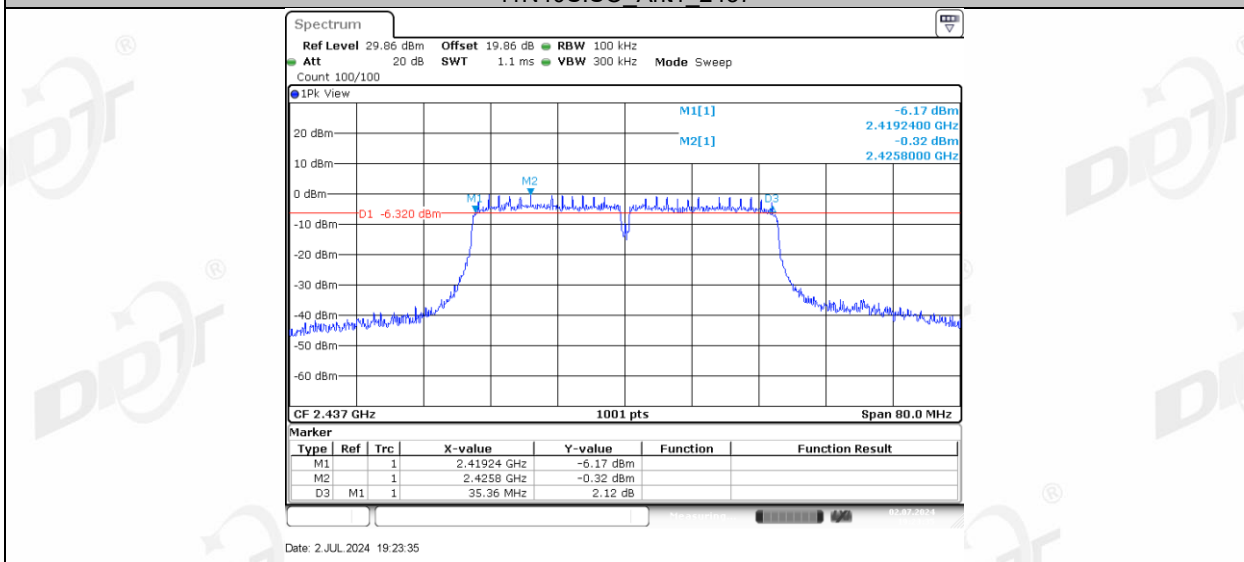
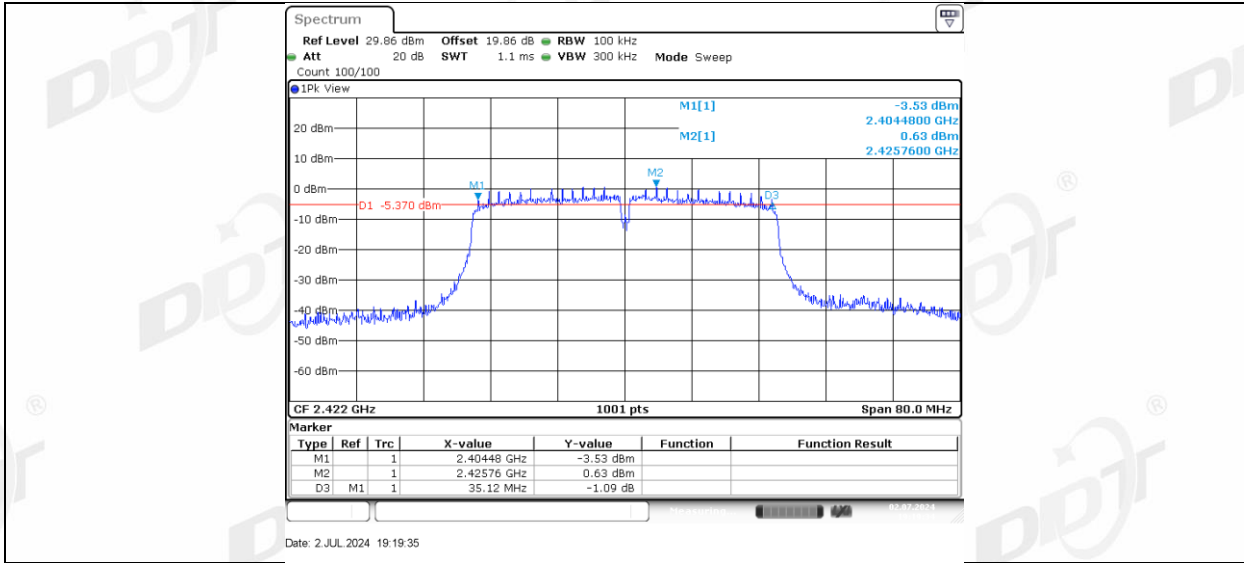

5. 99% Bandwidth

5.1. Block diagram of test setup

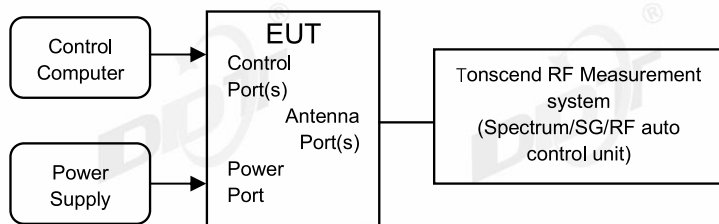

5.2. Limits

Just for Report.

5.3. Test procedure

- (1) The test according to ANSI C63.10-2013 clause 6.9.3.
- (2) Connect EUT's antenna output to spectrum analyzer by RF cable, the path loss was compensated to the results
- (3) Set the EUT as maximum power setting and enable the EUT transmit continuously
- (4) Use the following spectrum analyzer settings for the 99% Bandwidth:

RBW:	1% to 5% of the OBW
VBW:	approximately three times RBW
Span:	between 1.5 times and 5.0 times the OBW
Detector Mode:	peak
Sweep time:	auto
Trace mode	max hold

Allow the trace to stabilize, measure the 99% bandwidth of signal, and record the results in the report.

5.4. Test result

Test Engineer:	Zhongyao	Test Site:	RF Measurement System 3#
Ambient Condition:	26.4°C,43.5%RH	Test Date:	2024.07.02
Test Power Supply:	AC 120V	Sample Number:	S24060702-002

TestMode	Antenna	Channel Frequency[MHz]	OCB [MHz]	FL[MHz]	FH[MHz]	Limit[MHz]	Verdict
11B	Ant1	2412	12.987	2405.5265	2418.5135	---	---
		2437	13.107	2430.3666	2443.4735	---	---
		2462	12.987	2455.5265	2468.5135	---	---
11G	Ant1	2412	16.823	2403.6484	2420.4715	---	---
		2437	16.823	2428.5684	2445.3916	---	---
		2462	16.743	2453.6883	2470.4316	---	---
11N20SIS O	Ant1	2412	17.383	2403.3287	2420.7113	---	---
		2437	17.463	2428.2488	2445.7113	---	---
		2462	17.383	2453.3287	2470.7113	---	---
11N40SIS O	Ant1	2422	35.964	2404.0180	2439.9820	---	---
		2437	36.284	2418.8581	2455.1419	---	---
		2452	36.124	2434.0979	2470.2218	---	---

5.5. Test graphs



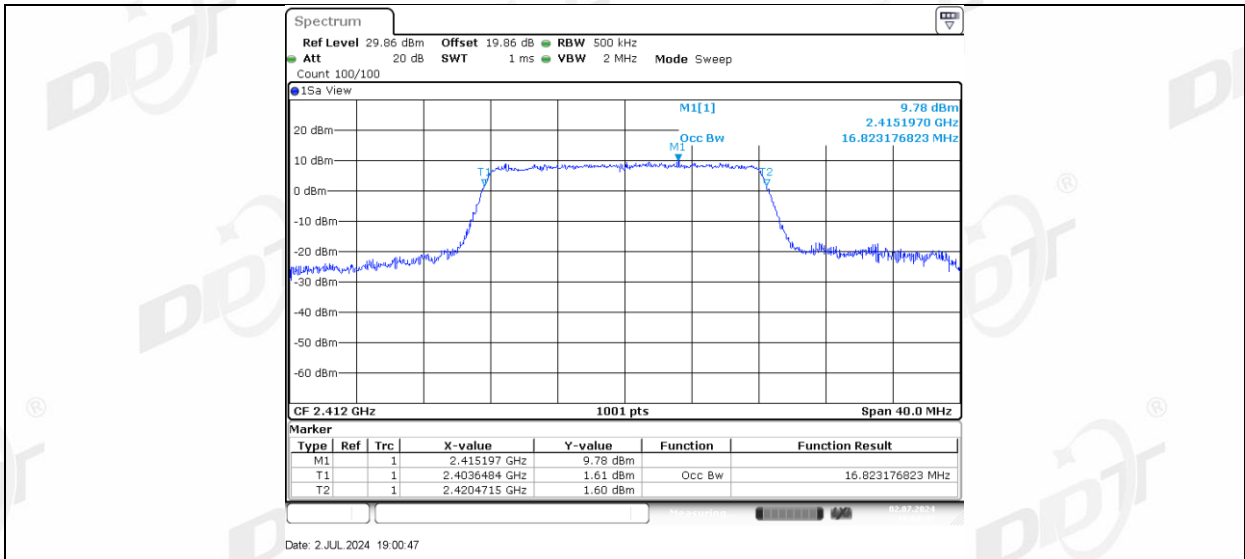

11G Ant1_2437

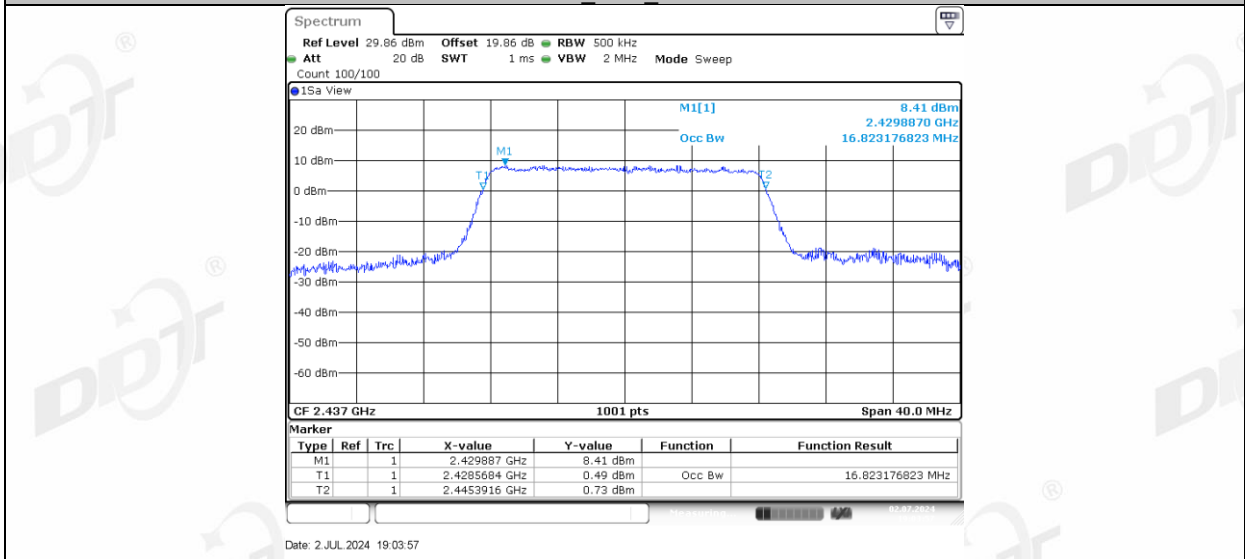

11G Ant1_2462

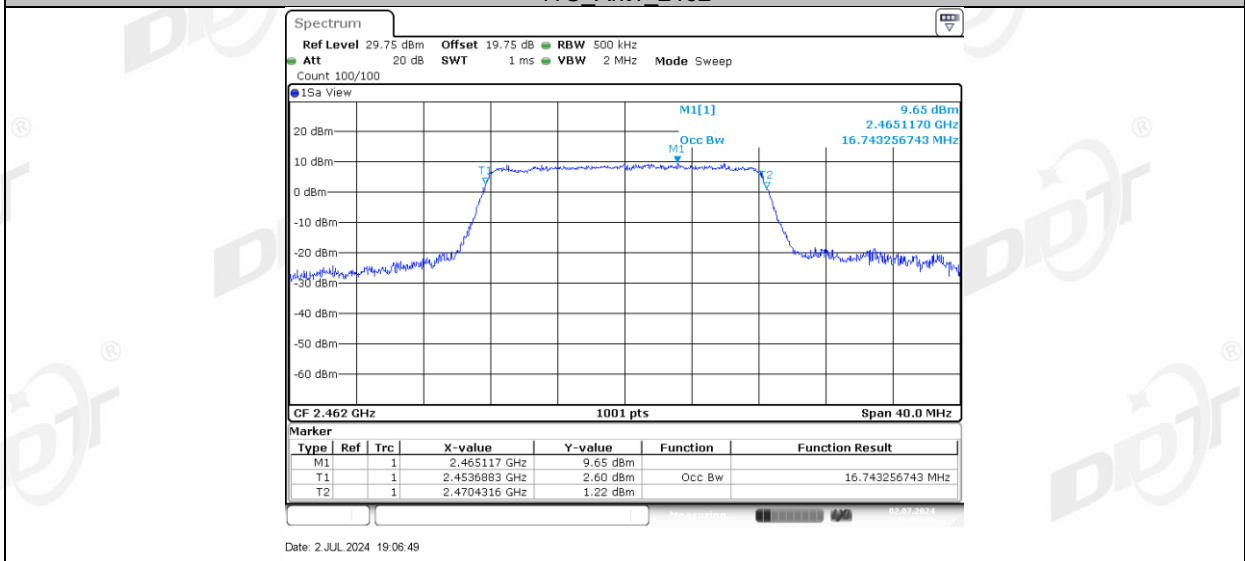

11N20SISO Ant1_2412

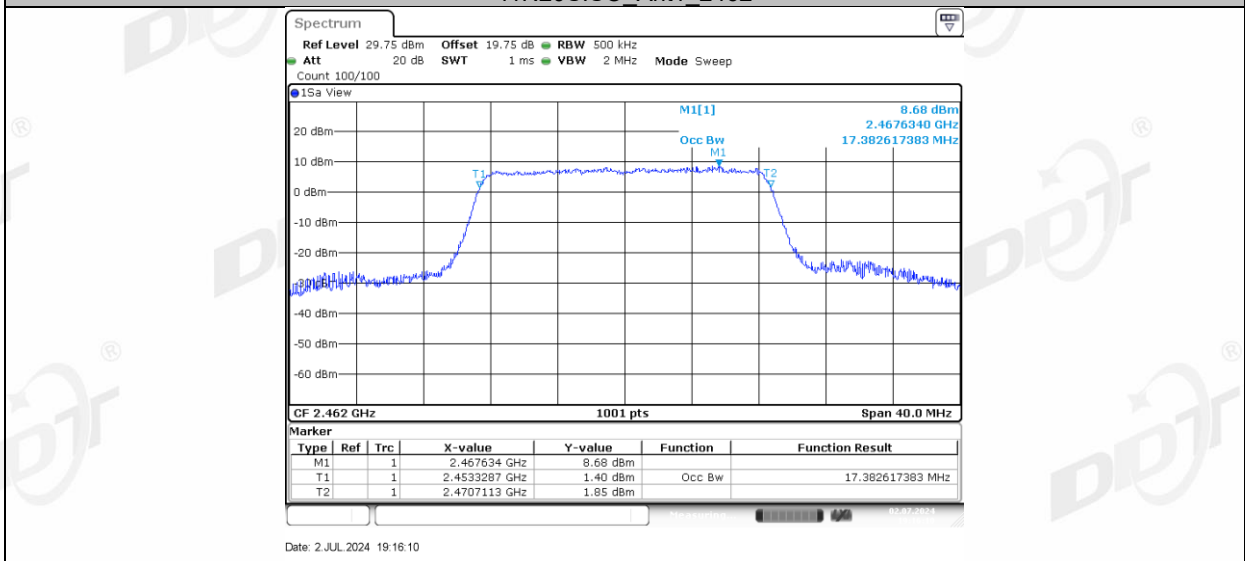
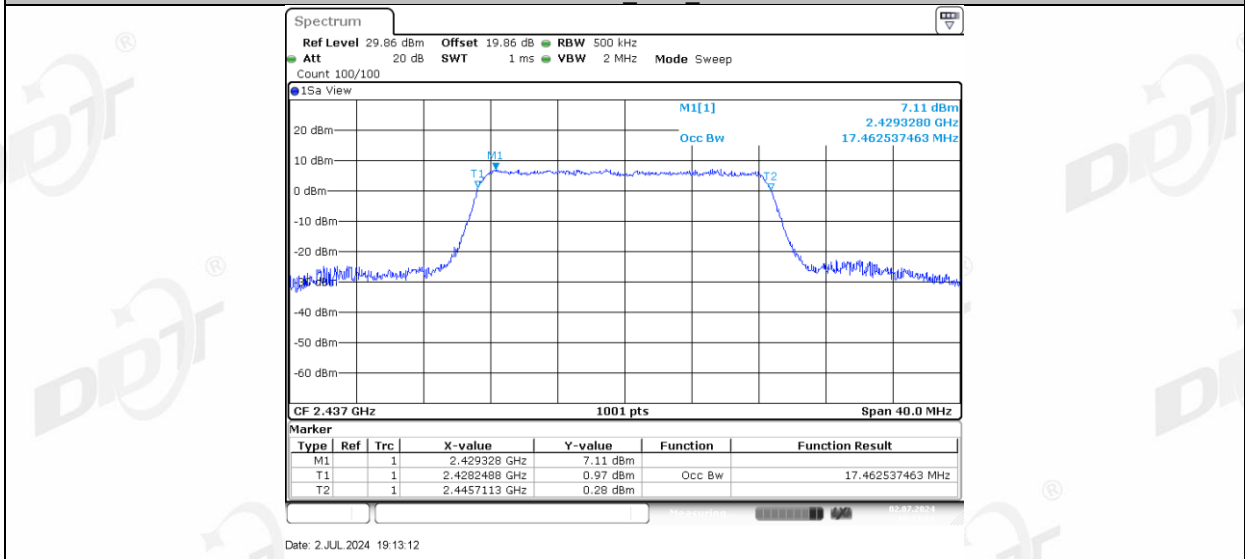
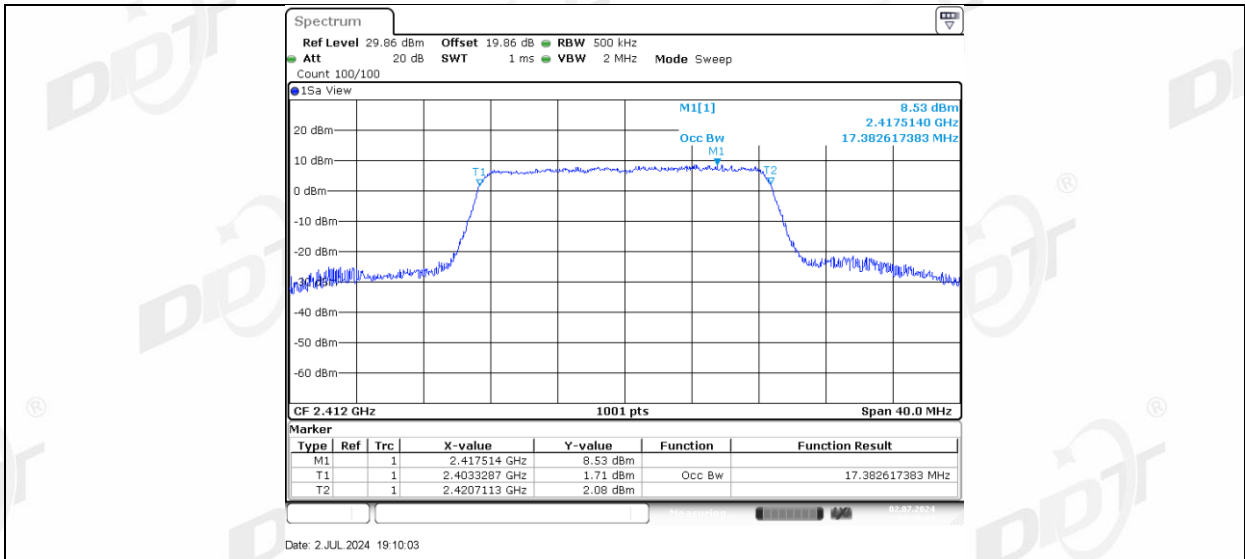

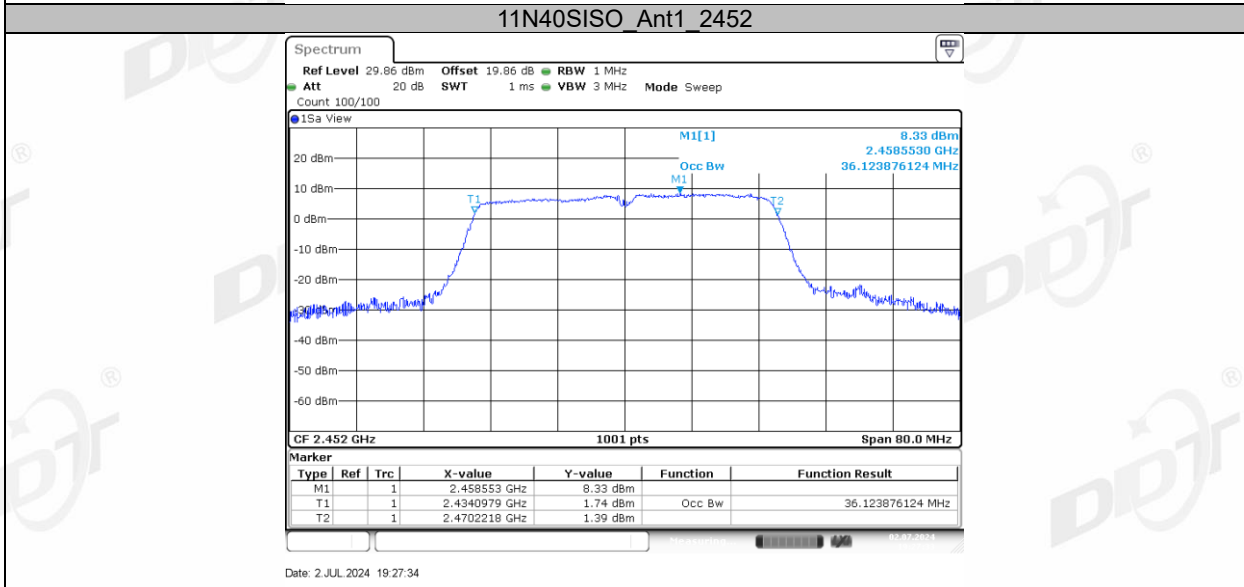
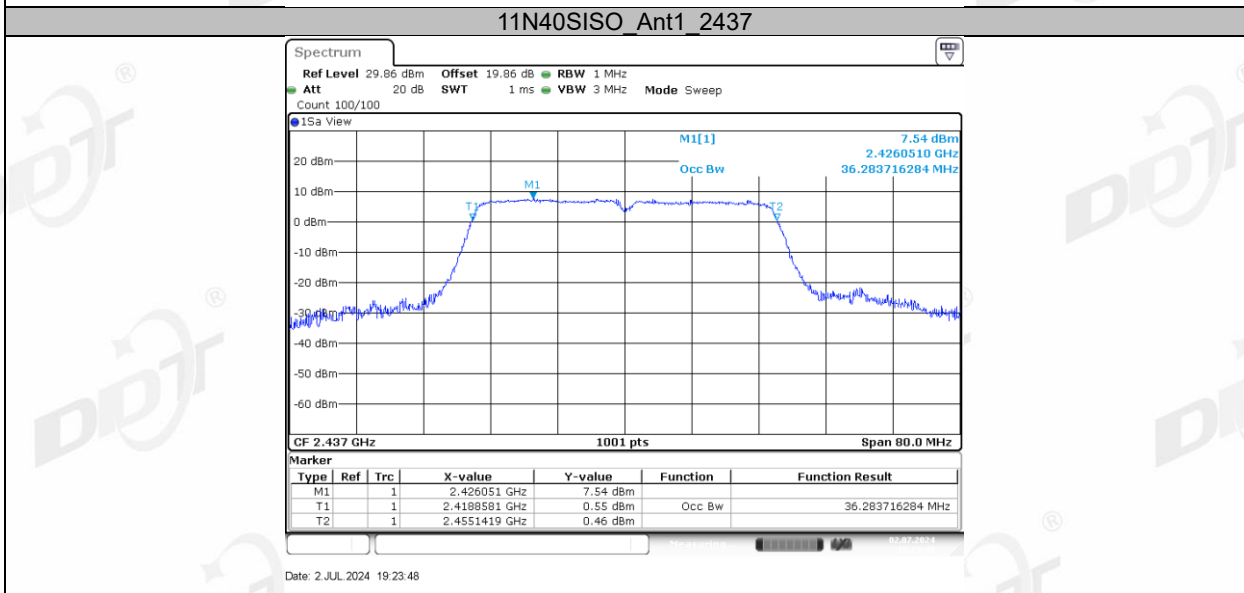
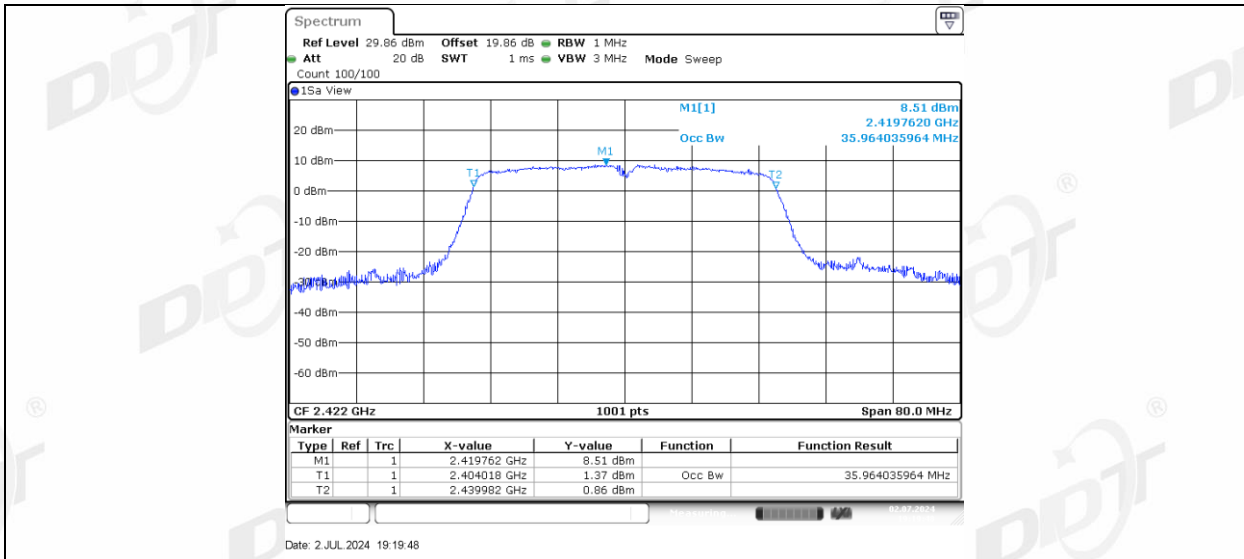

6. Conducted Output Power

6.1. Block diagram of test setup

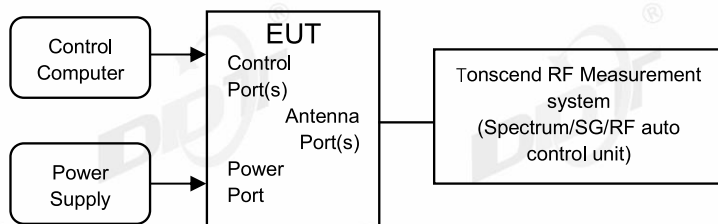

6.2. Limits

For systems using digital modulation in the 902-928 MHz, 2400-2483.5 MHz, and 5725-5850 MHz bands: 1 Watt. If transmitting antennas of directional gain greater than 6 dBi are used, the conducted output power from the intentional radiator shall be reduced below the stated values as appropriate, by the amount in dB that the directional gain of the antenna exceeds 6 dBi.

6.3. Test procedure

- (1) The test according to ANSI C63.10-2013 clause 11.9.2.3.
- (2) Connect EUT's antenna output to RF power meter by RF cable, the path loss was compensated to the results.
- (3) Set the EUT as maximum power setting and enable the EUT transmit continuously, If the transmitter does not transmit continuously, measure the duty cycle, D, of the transmitter output signal.
- (4) Measure the average power of the transmitter. This measurement is an average over both the ON and OFF periods of the transmitter.
- (5) Adjust the measurement in dBm by adding $[10 \log (1 / D)]$, where D is the duty cycle.
- (6) Record the RF average power of each antenna port.

6.4. Test result average

Test Engineer:	Zhongyao	Test Site:	RF Measurement System 3#
Ambient Condition:	26.4°C,43.5%RH	Test Date:	2024.07.02
Test Power Supply:	AC 120V	Sample Number:	S24060702-002

Test Mode	Antenna	Frequency [MHz]	Average power [dBm]	Duty Cycle [%]	DC Factor [dB]	Result [dBm]	Limit [dBm]	EIRP [dBm]	EIRP Limit [dBm]	Verdict
11B	Ant1	2412	16.22	100.00	0.00	16.22	≤30.00	19.09	≤36.00	PASS
		2437	15.92	100.00	0.00	15.92	≤30.00	18.79	≤36.00	PASS
		2462	15.92	100.00	0.00	15.92	≤30.00	18.79	≤36.00	PASS
11G	Ant1	2412	15.60	99.64	0.02	15.62	≤30.00	18.49	≤36.00	PASS
		2437	15.38	99.46	0.02	15.40	≤30.00	18.27	≤36.00	PASS
		2462	15.54	99.46	0.02	15.56	≤30.00	18.43	≤36.00	PASS
11N20SI SO	Ant1	2412	14.65	99.41	0.03	14.68	≤30.00	17.55	≤36.00	PASS
		2437	14.45	99.61	0.02	14.47	≤30.00	17.34	≤36.00	PASS
		2462	14.58	99.61	0.02	14.60	≤30.00	17.47	≤36.00	PASS
11N40SI SO	Ant1	2422	14.46	98.80	0.05	14.51	≤30.00	17.38	≤36.00	PASS
		2437	14.17	99.20	0.03	14.20	≤30.00	17.07	≤36.00	PASS
		2452	14.36	98.80	0.05	14.41	≤30.00	17.28	≤36.00	PASS

Note: EIRP (dBm)=Conducted Output Power (dBm)+ Antenna Gain (dBi)

7. Power Spectral Density

7.1. Block diagram of test setup

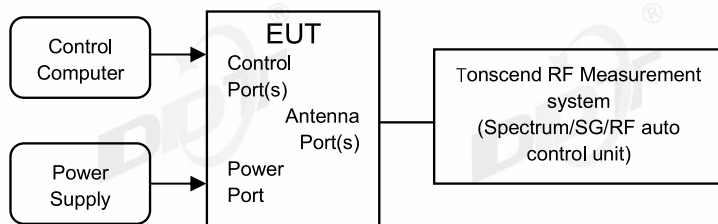

7.2. Limits

For digitally modulated systems, the power spectral density conducted from the intentional radiator to the antenna shall not be greater than 8 dBm in any 3 kHz band during any time interval of continuous transmission.

7.3. Test procedure

- (1) The test according to ANSI C63.10-2013 clause 11.10.5.
- (2) Connect EUT's antenna output to spectrum analyzer by RF cable, the path loss was compensated to the results.
- (3) Set the EUT as maximum power setting and enable the EUT transmit continuously.
- (4) Use the following spectrum analyzer settings for Power Spectral Density measurement:

Center frequency	DTS Channel center frequency
RBW:	$3 \text{ kHz} \leq \text{RBW} \leq 100 \text{ kHz}$
VBW:	$\geq 3\text{RBW}$
Span	1.5 times the DTS bandwidth
Detector Mode:	RMS
Sweep time:	auto
Trace mode	max hold
	Employ trace averaging (rms)
Trace	mode over a minimum of 100 traces.

(5) Add $[10 \log (1 / D)]$, where D is the duty cycle measured in step a), to the measured PSD to compute the average PSD during the actual transmission time.

If measured value exceeds limit, reduce RBW (no less than 3 kHz) and repeat.

7.4. Test result

Test Engineer:	Zhongyao	Test Site:	RF Measurement System 3#
Ambient Condition:	26.4°C,43.5%RH	Test Date:	2024.07.02
Test Power Supply:	AC 120V	Sample Number:	S24060702-002

Test Mode	Antenna	Frequency [MHz]	Result[dBm/3-100kHz]	Limit[dBm/3kHz]	Verdict
11B	Ant1	2412	-15.45	≤8.00	PASS
		2437	-16.63	≤8.00	PASS
		2462	-15.38	≤8.00	PASS
11G	Ant1	2412	-17.34	≤8.00	PASS
		2437	-18.02	≤8.00	PASS
		2462	-17.31	≤8.00	PASS
11N20SISO	Ant1	2412	-18.43	≤8.00	PASS
		2437	-18.66	≤8.00	PASS
		2462	-17.15	≤8.00	PASS
11N40SISO	Ant1	2422	-23.42	≤8.00	PASS
		2437	-24.22	≤8.00	PASS
		2452	-23.75	≤8.00	PASS

Note: The Duty Cycle Factor is compensated in the graph.

7.5. Test graphs

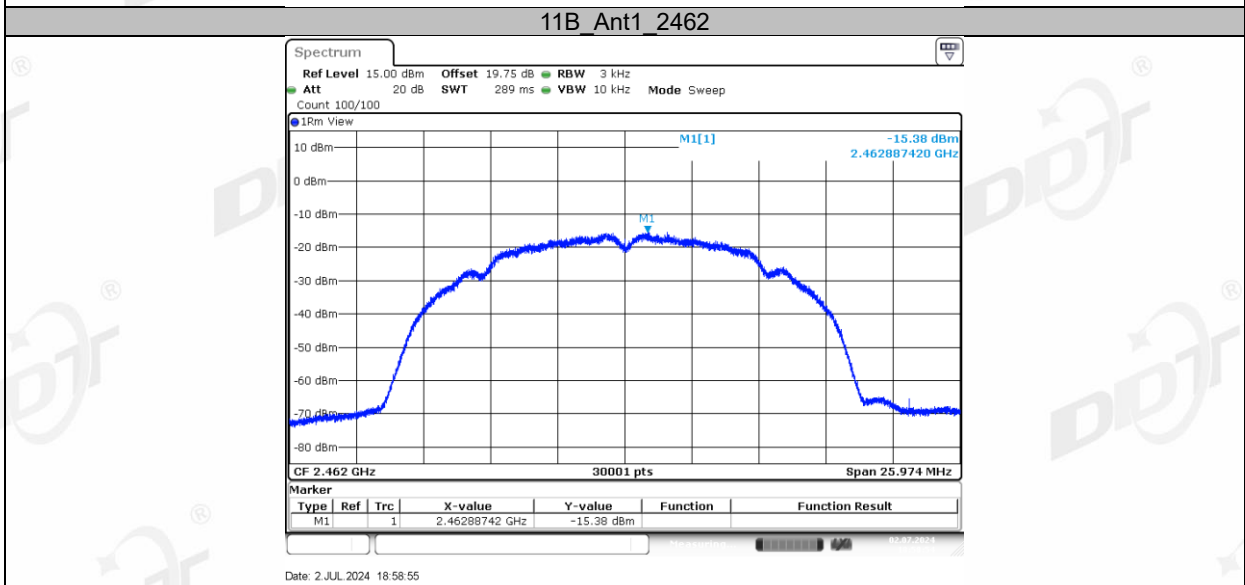
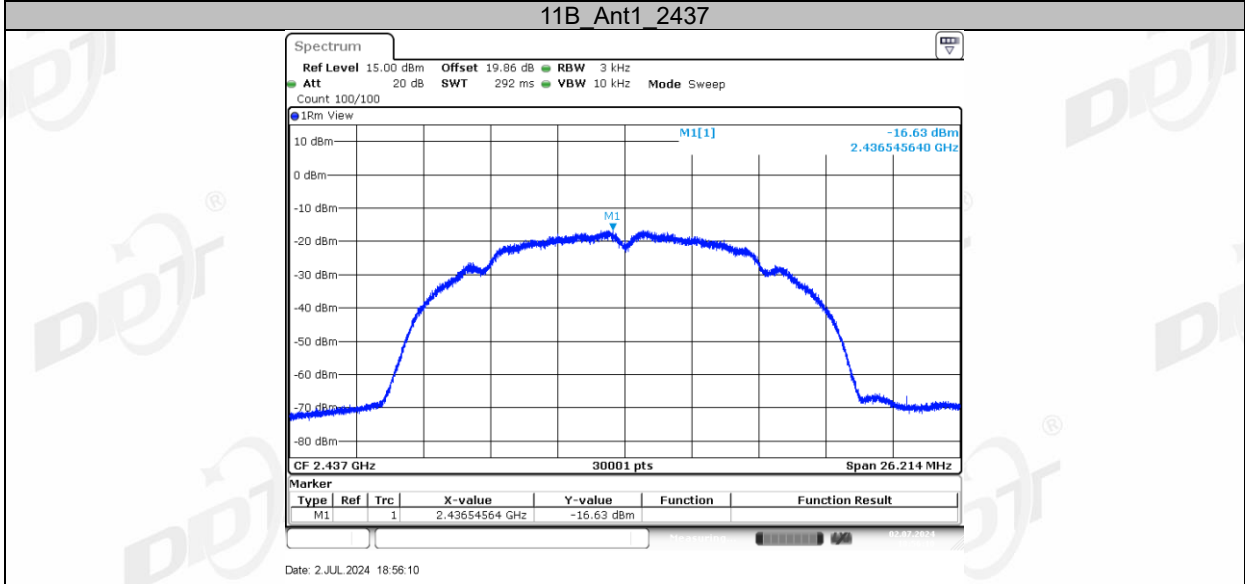
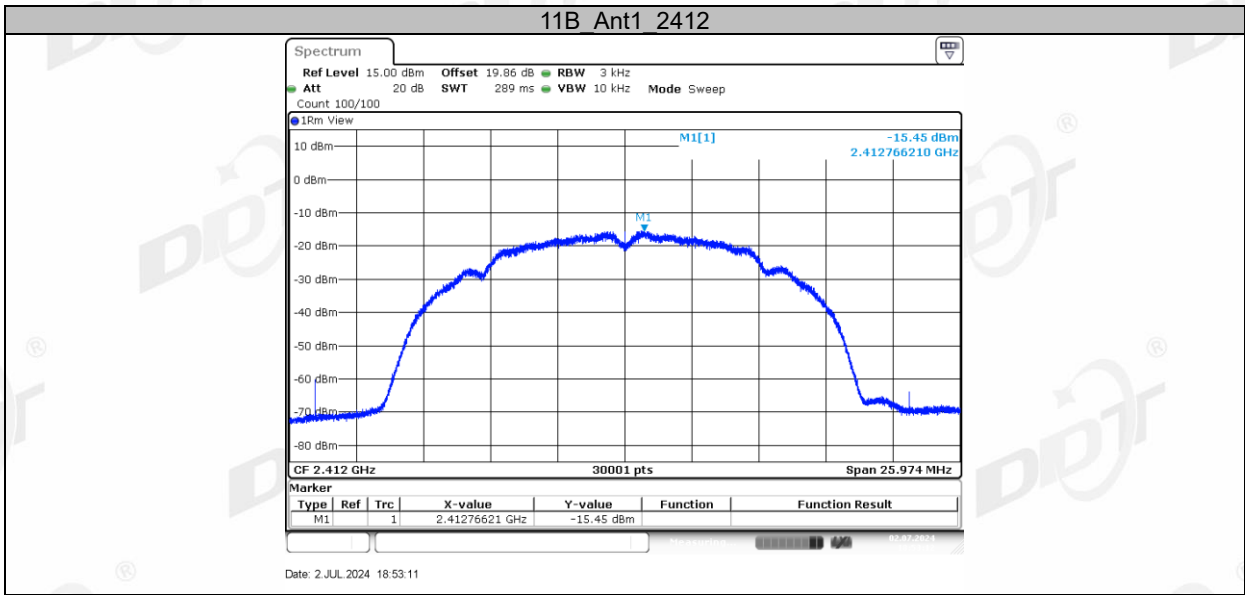

11G Ant1_2412

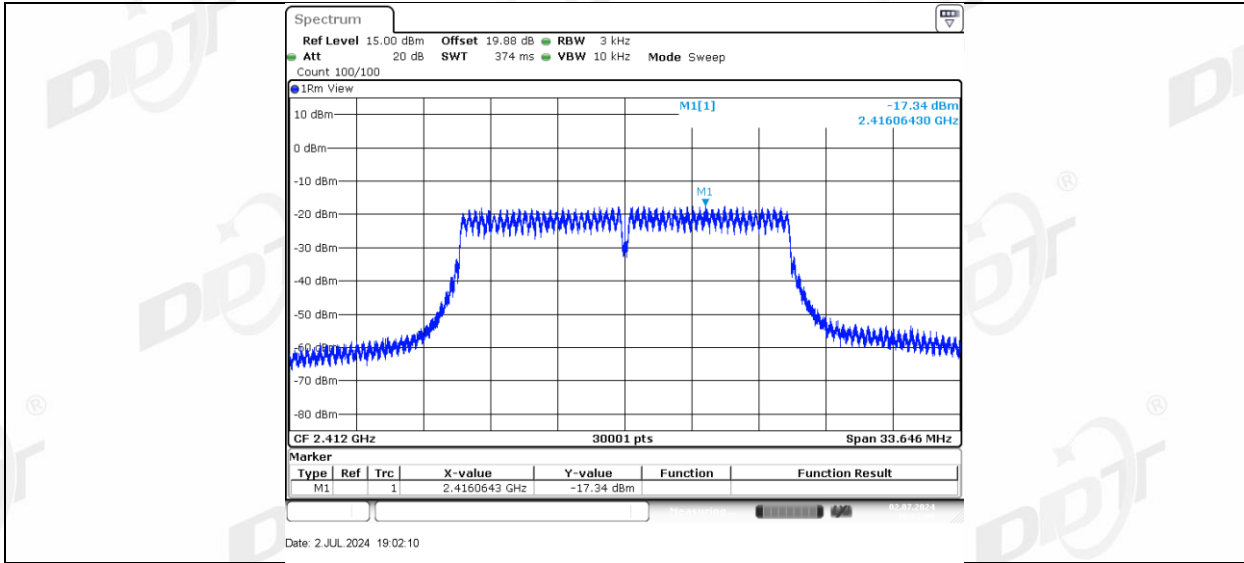

11G Ant1_2437

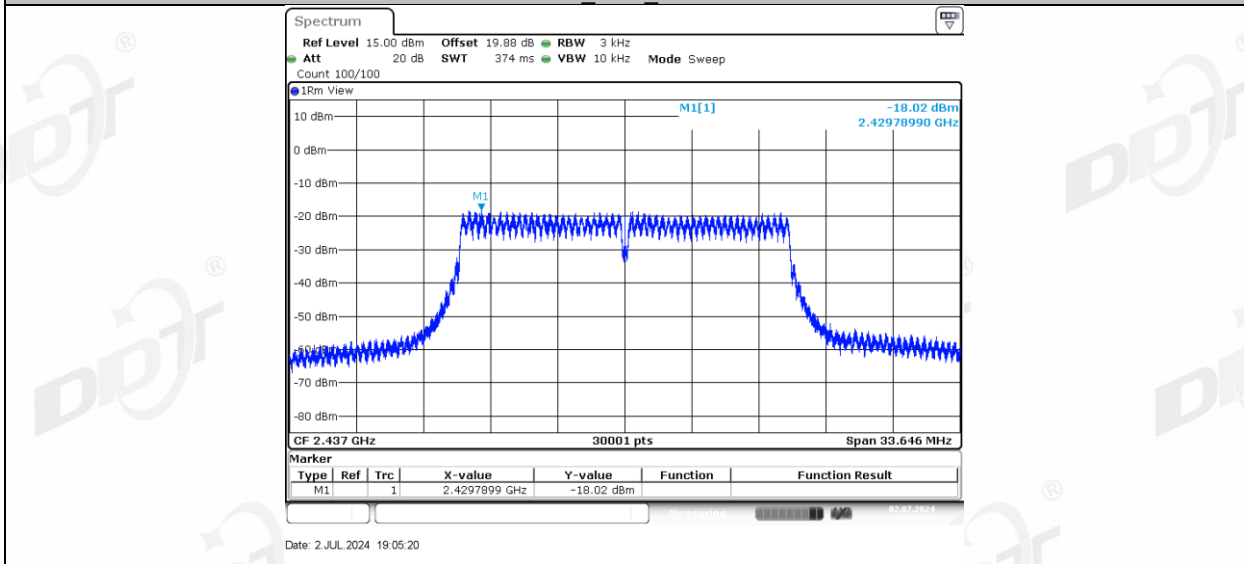

11G Ant1_2462

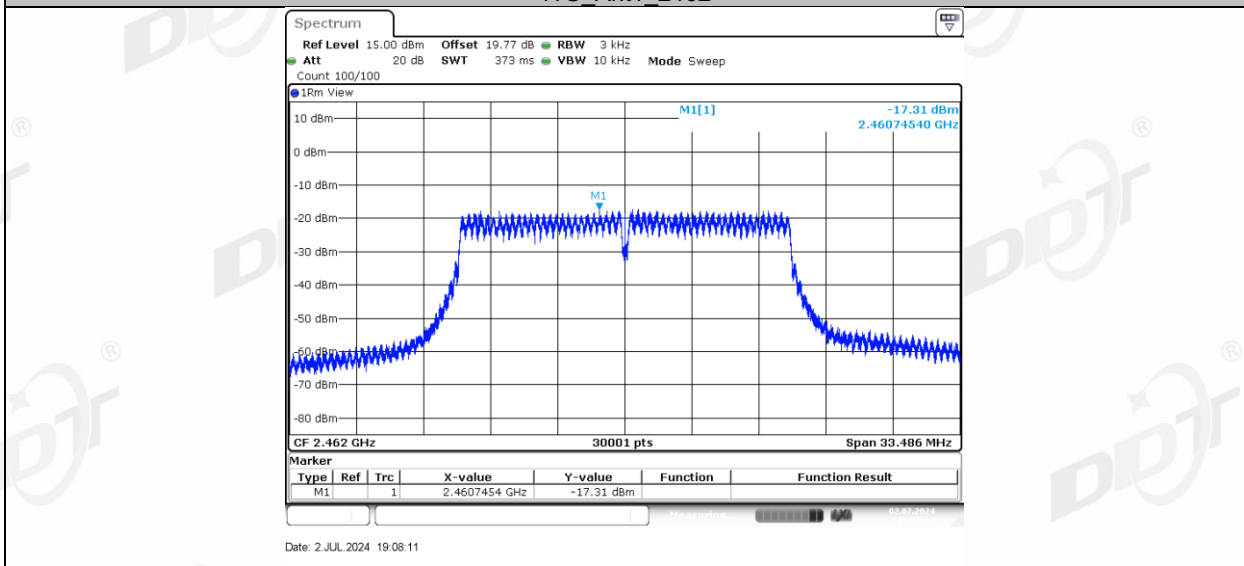

11N20SISO Ant1_2412

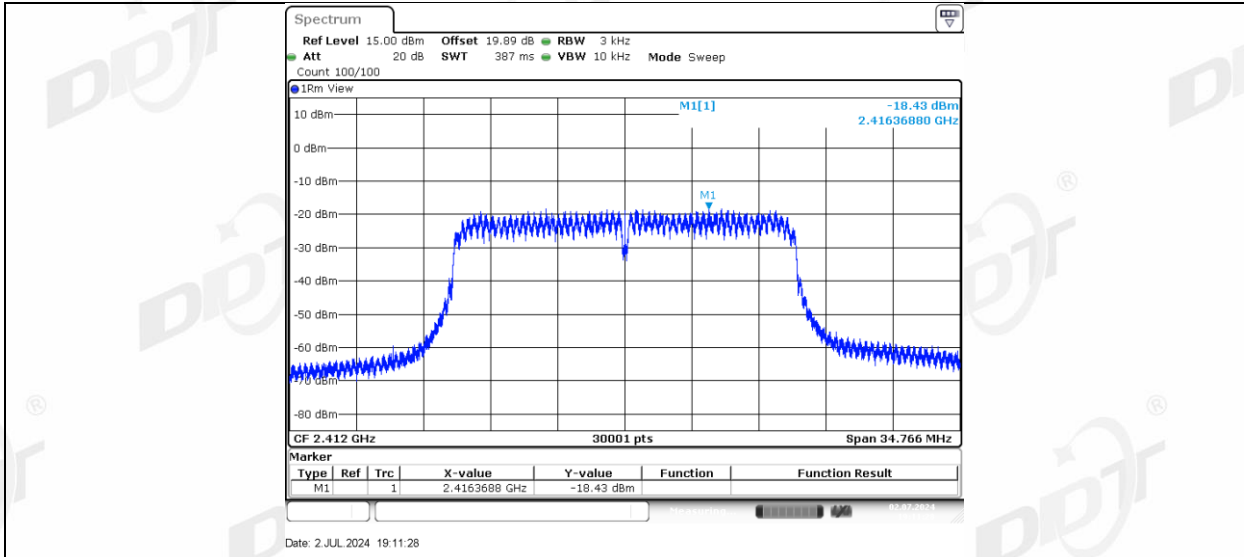

11N20SISO_Ant1_2437

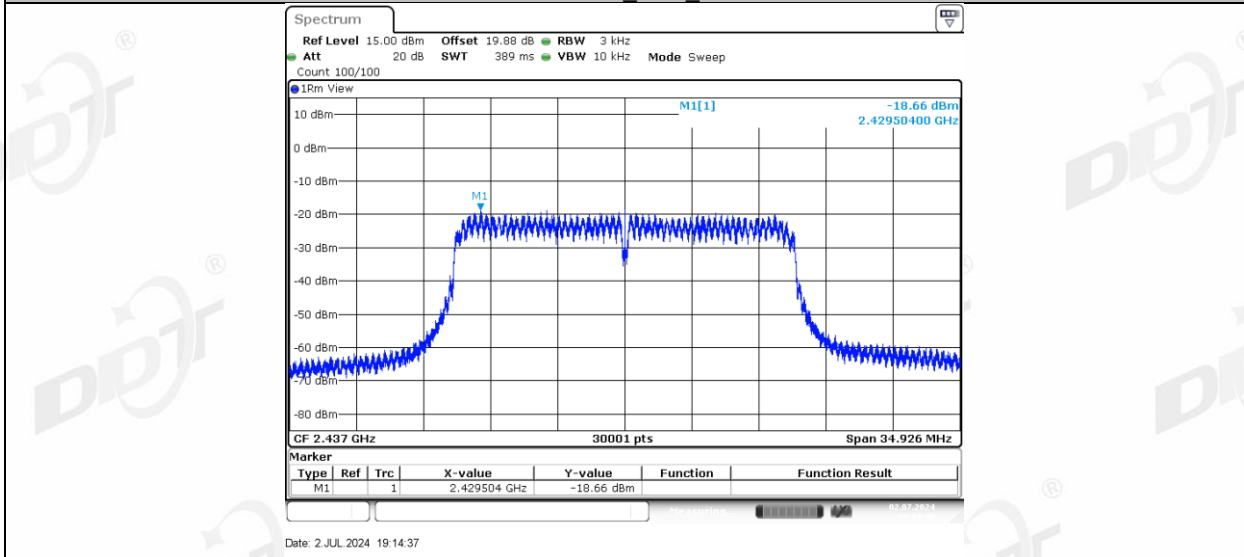

11N20SISO_Ant1_2462

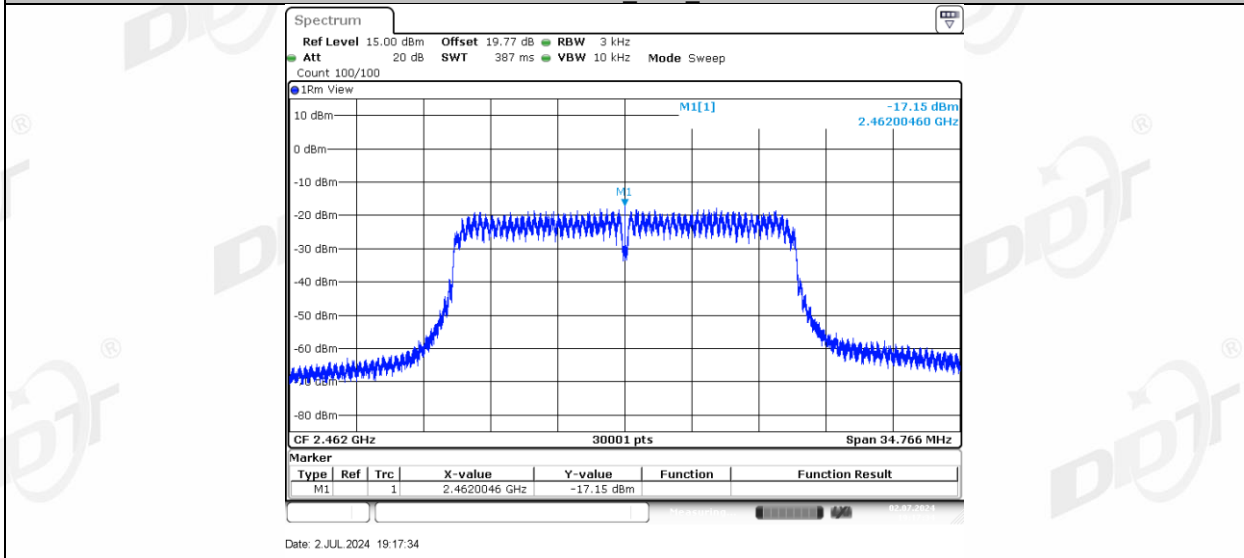

11N40SISO_Ant1_2422

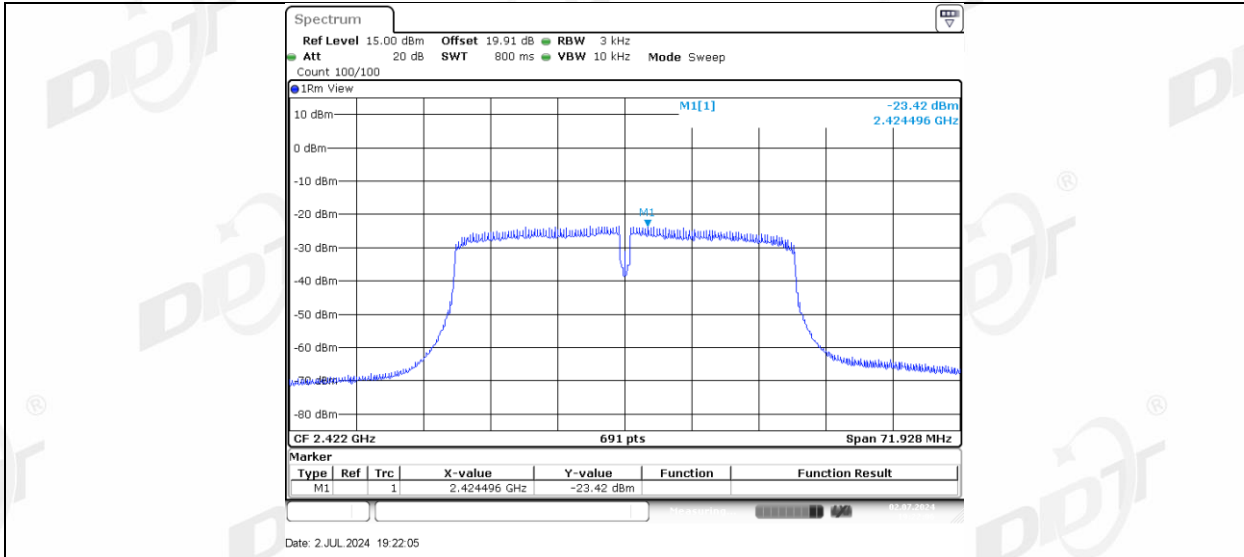

11N40SISO_Ant1_2437

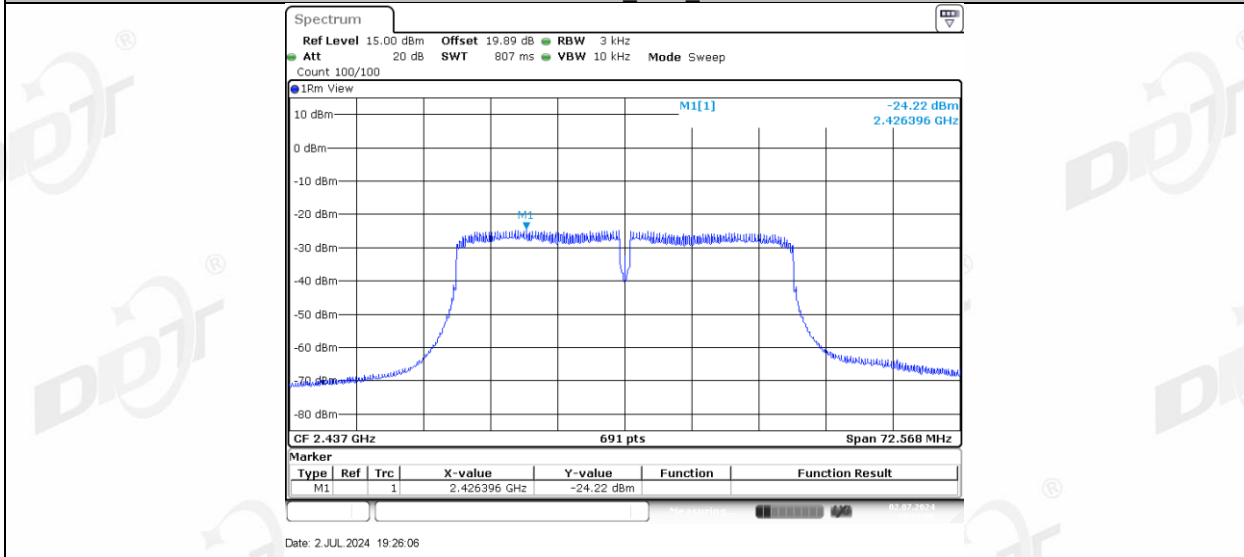

11N40SISO_Ant1_2452

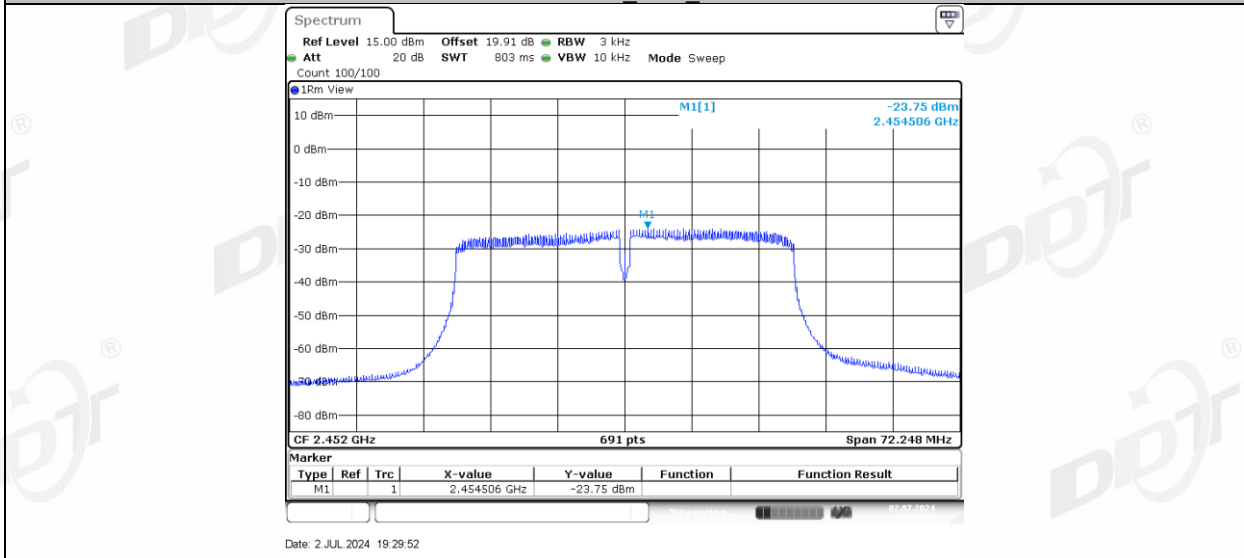

8. Band Edge Compliance (Conducted Method)

8.1. Block diagram of test setup

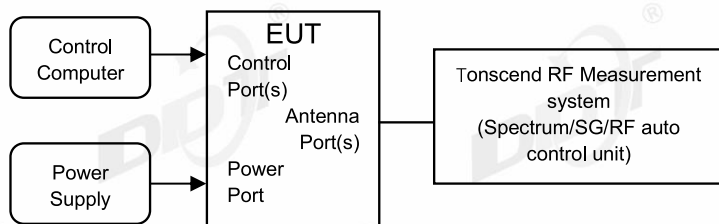

8.2. Limits

In any 100 kHz bandwidth outside the frequency bands in which the spread spectrum intentional radiator is operating, the radio frequency power that is produced by the intentional radiator shall be at least 30 dB below that in the 100 kHz bandwidth within the band that contains the highest level of the desired power.

8.3. Test procedure

(1) Connect EUT's antenna output to spectrum analyzer by RF cable.

(2) Establish a reference level by using the following procedure:

RBW: 100 kHz

VBW: 300 kHz

Span Encompass frequency range to be measured

Detector Mode: Peak

Sweep time: auto

Trace mode Max hold

(3) Allow the trace to stabilize, use the peak marker function to determine the maximum peak power level to establish the reference level.

Then mark the maximum amplitude of all unwanted emissions outside of the authorized frequency band.

8.4. Test result

Test Engineer:	Zhongyao	Test Site:	RF Measurement System 3#
Ambient Condition:	26.4°C,43.5%RH	Test Date:	2024.07.02
Test Power Supply:	AC 120V	Sample Number:	S24060702-002

EUT Set Mode	CH or Frequency	Result(dBm)	EUT Set Mode	CH or Frequency	Result (dBm)
11b	CH1	Pass	11g	CH1	Pass
	CH11	Pass		CH11	Pass
11n HT 20	CH1	Pass	11n HT 40	CH3	Pass
	CH11	Pass		CH9	Pass

8.5. Test graphs

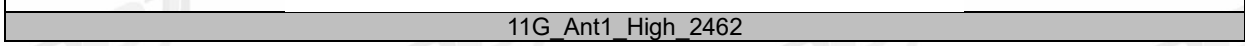
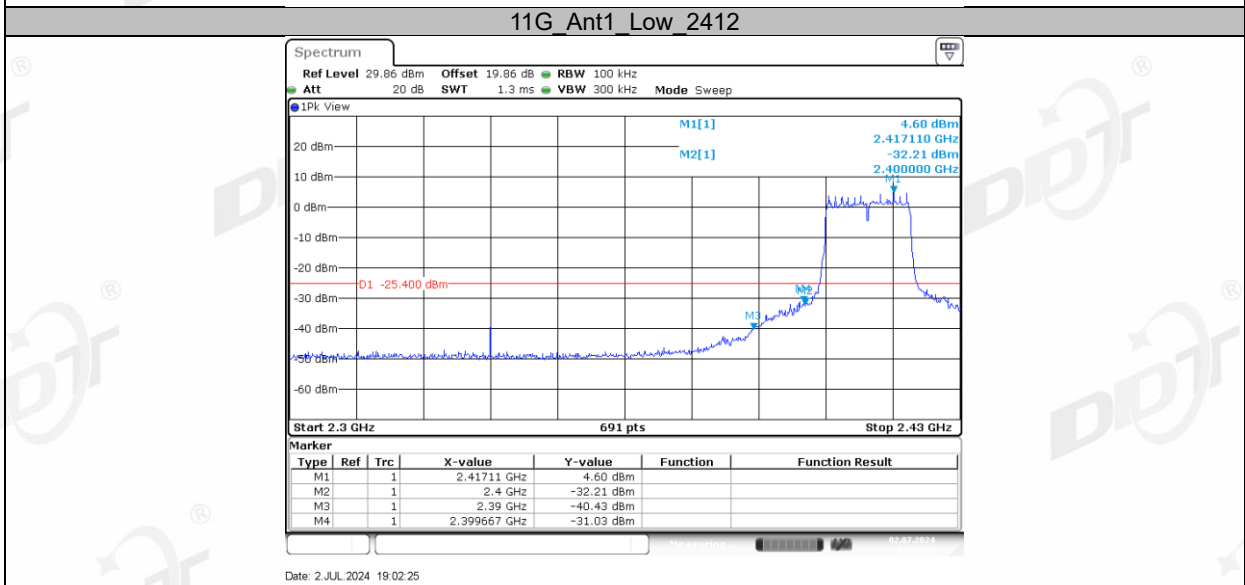
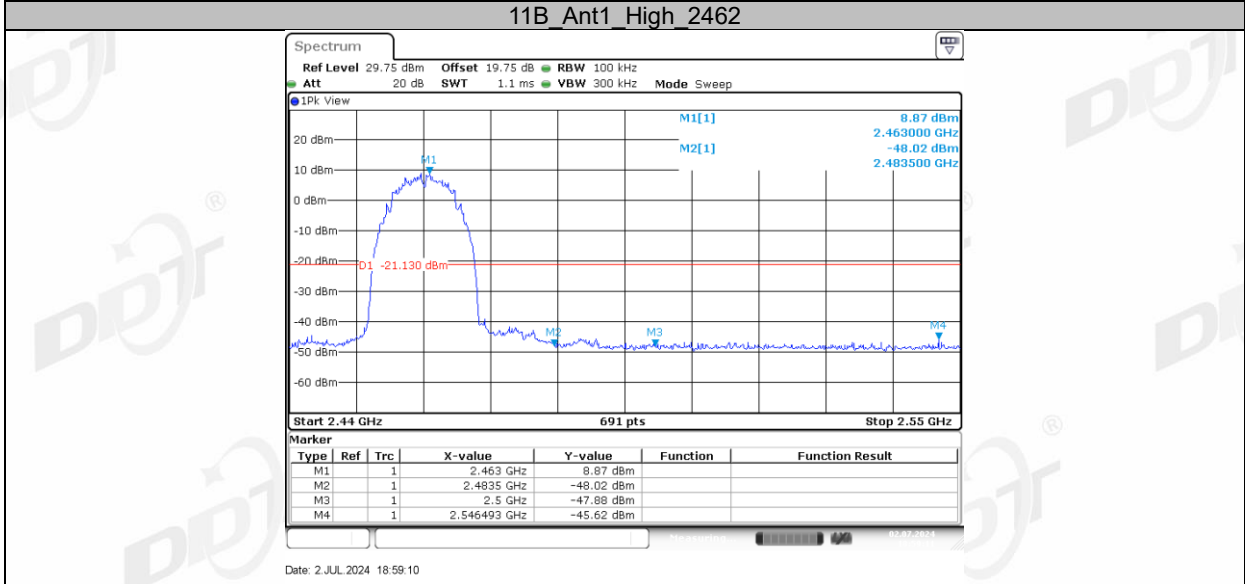
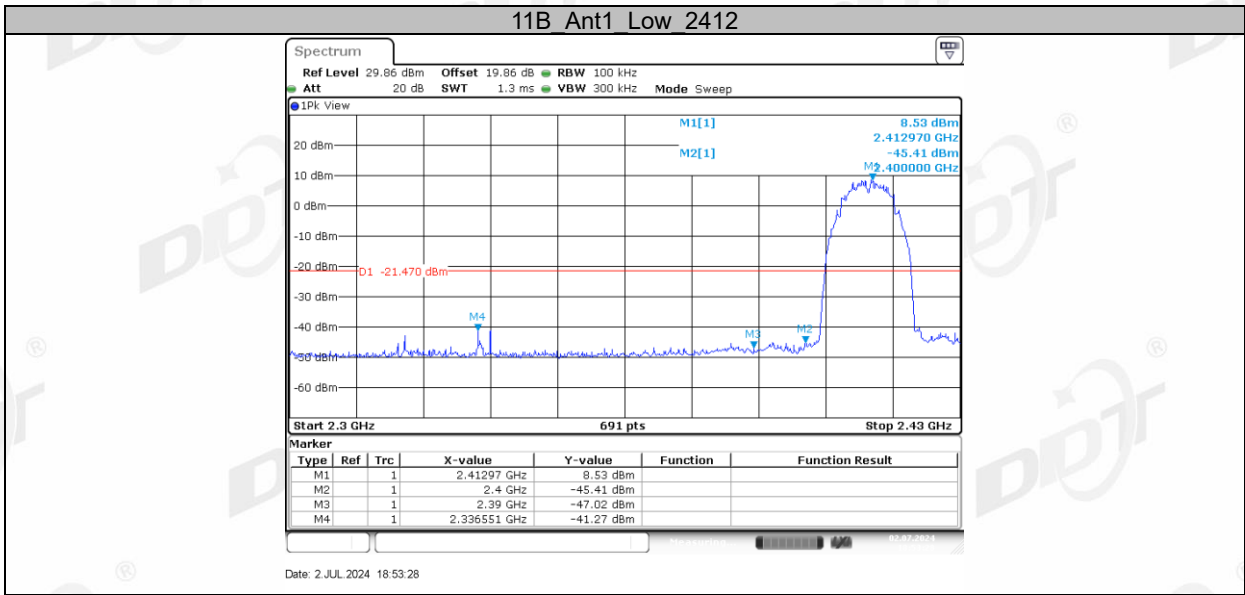

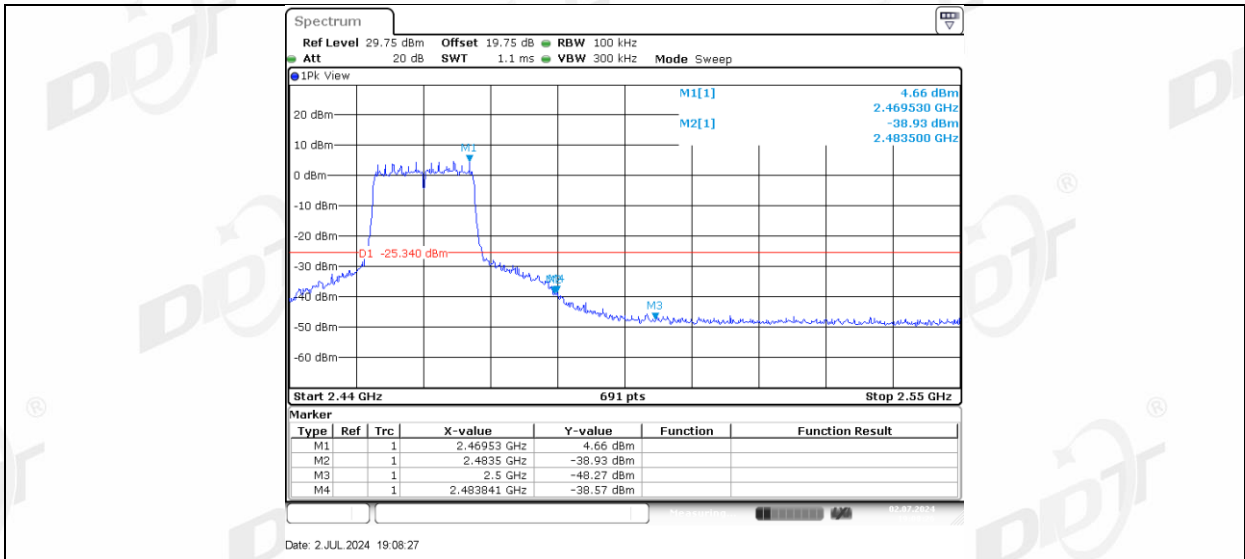

11N20SISO_Ant1_Low_2412

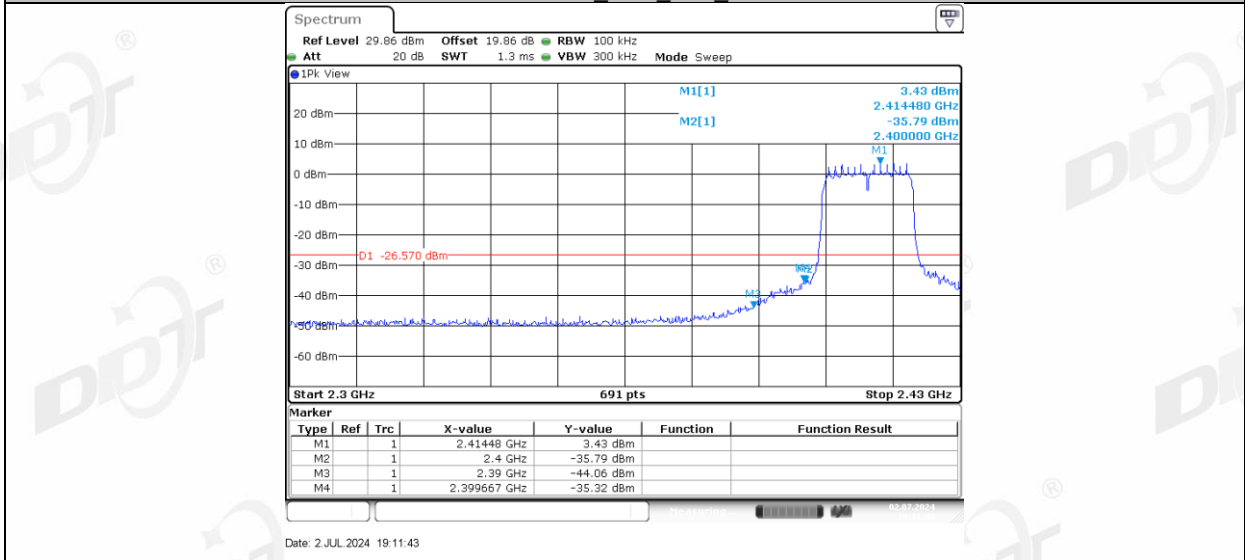

11N20SISO_Ant1_High_2462

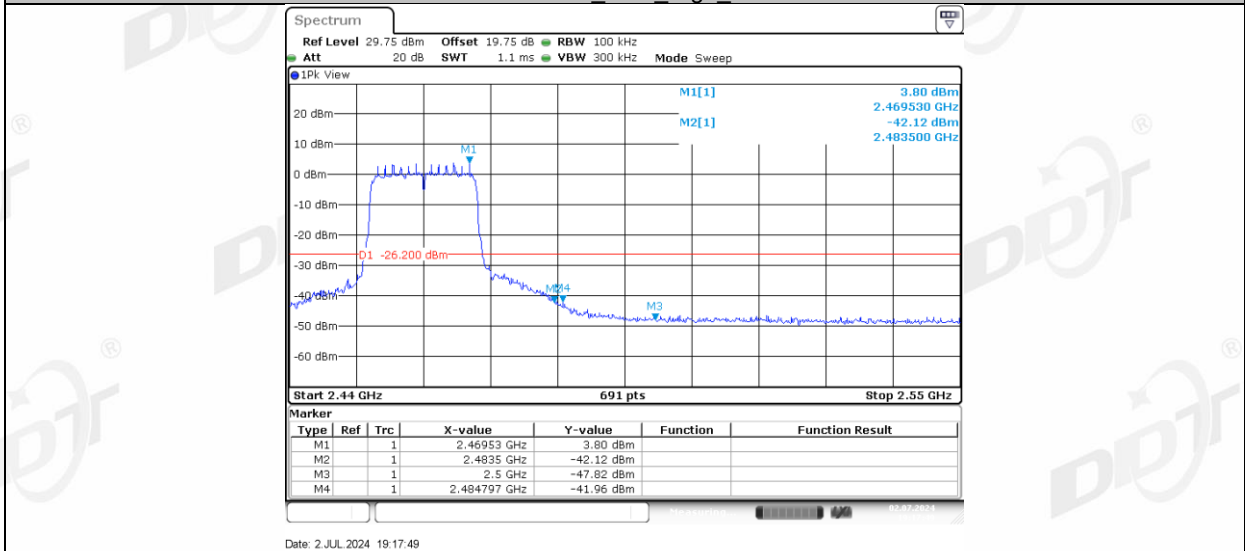

11N40SISO_Ant1_Low_2422

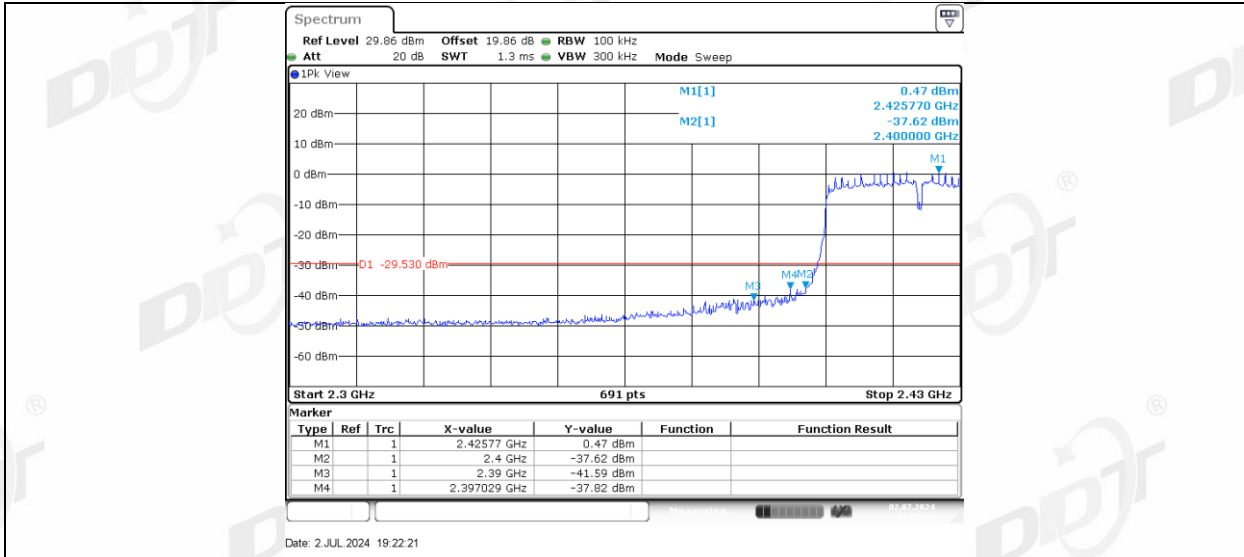

11N40SISO_Ant1_High_2452

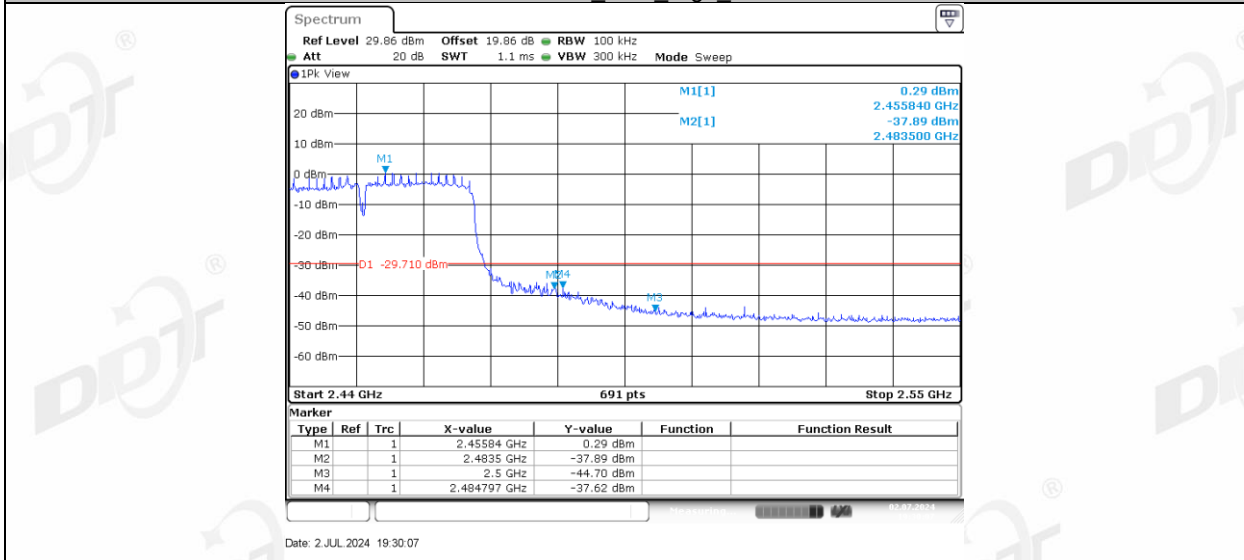

9. RF Conducted Spurious Emissions

9.1. Block diagram of test setup

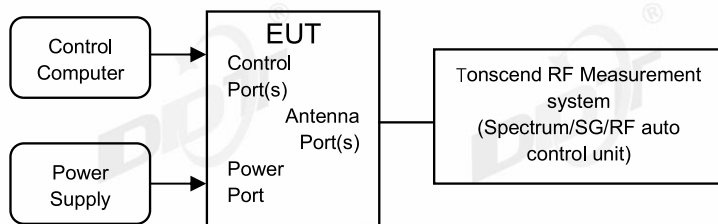

9.2. Limits

In any 100 kHz bandwidth outside the frequency bands in which the spread spectrum intentional radiator is operating, the radio frequency power that is produced by the intentional radiator shall be at least 30 dB below that in the 100 kHz bandwidth within the band that contains the highest level of the desired power.

9.3. Test procedure

(1) Connect EUT's antenna output to spectrum analyzer by RF cable.

(2) Establish a reference level by using the following procedure:

Center frequency	Test frequency
RBW:	100 kHz
VBW:	300 kHz
Span	Wide enough to capture the peak level of the in-band emission
Detector Mode:	Peak
Sweep time:	auto
Trace mode	Max hold

(3) Allow the trace to stabilize, use the peak marker function to determine the maximum peak power level to establish the reference level.

(4) Set the spectrum analyzer as follows:

RBW:	100 kHz
VBW:	300 kHz
Span	Encompass frequency range to be measured
Number of measurement points	$\geq \text{Span}/\text{RBW}$
Detector Mode:	Peak
Sweep time:	auto
Trace mode	Max hold

- (5) Allow the trace to stabilize, use the peak marker function to determine the maximum amplitude of all unwanted emissions outside of the authorized frequency band

9.4. Test result

Test Engineer:	Zhongyao	Test Site:	RF Measurement System 3#
Ambient Condition:	26.4°C,43.5%RH	Test Date:	2024.07.02
Test Power Supply:	AC 120V	Sample Number:	S24060702-002

EUT Set Mode	CH or Frequency	Result(dBm)	EUT Set Mode	CH or Frequency	Result (dBm)
11b	CH1	Pass	11g	CH1	Pass
	CH11	Pass		CH11	Pass
11n HT 20	CH1	Pass	11n HT 40	CH3	Pass
	CH11	Pass		CH9	Pass

9.5. Test graphs

