

# TEST REPORT

**Report Number: 103541366MPK-009**

**Project Number: G103541366**

**August 08, 2018**

**Testing performed on  
Real Immersive System**

**Model: Model 0**

**Part Number: 13767 (HMD, Head Mounted Display)**

**FCC ID: 2AQU7-REAL00**

**IC: 24199-REAL00**

**to**

**FCC Part 15 Subpart C (15.247)**

**Industry Canada RSS-247 Issue 2**

**For**

**Penumbra, Inc.**

Test Performed by:

Intertek

1365 Adams Court

Menlo Park, CA 94025 USA

Test Authorized by:

Penumbra, Inc.

One Penumbra Place

Alameda, CA 94502 USA

Prepared by: \_\_\_\_\_

  
Anderson Soungpanya

**Date:** August 08, 2018

Reviewed by: \_\_\_\_\_

  
Krishna K Vemuri

**Date:** August 08, 2018

*This report is for the exclusive use of Intertek's Client and is provided pursuant to the agreement between Intertek and its Client. Intertek's responsibility and liability are limited to the terms and conditions of the agreement. Intertek assumes no liability to any party, other than to the Client in accordance with the agreement, for any loss, expense or damage occasioned by the use of this report. Only the Client is authorized to copy or distribute this report and then only in its entirety. Any use of the Intertek name or one of its marks for the sale or advertisement of the tested material, product or service must first be approved in writing by Intertek. The observations and test results in this report are relevant only to the sample tested. This report by itself does not imply that the material, product, or service is or has ever been under an Intertek certification program. This report must not be used to claim product endorsement by A2LA, NIST nor any other agency of the U.S. Government.*

Report No. 103541366MPK-009	
<b>Equipment Under Test:</b>	Real Immersive System - Head Mounted Display
<b>Trade Name:</b>	Penumbra, Inc.
<b>Model Number:</b>	Model 0
<b>Part Number:</b>	13767
<b>Applicant:</b>	Penumbra, Inc.
<b>Contact:</b>	Royal Wang
<b>Address:</b>	Penumbra, Inc. One Penumbra Place Alameda, CA 94502
<b>Country:</b>	USA
<b>Tel. Number:</b>	(209) 640-9328
<b>Email:</b>	rwang@penunbrainc.com
<b>Applicable Regulation:</b>	FCC Part 15 Subpart C (15.247) Industry Canada RSS-247 Issue 2
<b>Date of Test:</b>	July 06-24, 2018

*We attest to the accuracy of this report:*



Anderson Soungpanya  
Project Engineer



Krishna K Vemuri  
Engineering Team Lead

**TABLE OF CONTENTS**

**1.0 Summary of Tests ..... 4**

**2.0 General Information ..... 5**

2.1 Product Description ..... 5

2.2 Related Submittal(s) Grants ..... 6

2.3 Test Facility ..... 6

2.4 Test Methodology ..... 6

2.5 Measurement Uncertainty ..... 6

**3.0 System Test Configuration ..... 7**

3.1 Support Equipment ..... 7

3.2 Block Diagram of Test Setup ..... 7

3.3 Justification ..... 8

3.4 Software Exercise Program ..... 8

3.5 Mode of Operation during Test ..... 9

3.6 Modifications Required for Compliance ..... 9

3.7 Additions, Deviations and Exclusions from Standards ..... 9

**4.0 Measurement Results ..... 10**

4.1 6-dB Bandwidth and 99% Occupied Bandwidth ..... 10

4.2 Maximum Peak Conducted Output Power at Antenna Terminals ..... 17

4.3 Maximum Power Spectral Density ..... 21

4.4 Out of Band Antenna Conducted Emission ..... 25

4.5 Transmitter Radiated Emissions ..... 30

**5.0 List of Test Equipment ..... 69**

**6.0 Document History ..... 70**

**1.0 Summary of Tests**

<b>Test</b>	<b>Reference FCC</b>	<b>Reference Industry Canada</b>	<b>Result</b>
<b>RF Output Power</b>	15.247(b)(3)	RSS-247, 5.4.4	Complies
<b>6 dB Bandwidth</b>	15.247(a)(2)	RSS-247, 5.2.1	Complies
<b>Power Density</b>	15.247(e)	RSS-247, 5.2.2	Complies
<b>Out of Band Antenna Conducted Emission</b>	15.247(d)	RSS-247, 5.5	Complies
<b>Transmitter Radiated Emissions</b>	15.247(d), 15.209, 15.205	RSS-247, 5.5	Complies
<b>AC Line Conducted Emission</b>	15.207	RSS-GEN	Not Applicable – EUT is battery operated and non-rechargeable
<b>Antenna Requirement</b>	15.203	RSS-GEN	Complies (Internal Antenna)

**EUT receive date:** July 05, 2018

**EUT receive condition:** The pre-production version of the EUT was received in good condition with no apparent damage. As declared by the Applicant, it is identical to the production units.

**Test start date:** July 06, 2018

**Test completion date:** July 24, 2018

The test results in this report pertain only to the item tested.

**2.0 General Information**

2.1 Product Description

Penumbra, Inc. supplied the following description of the EUT:

Real Immersive System is a digital hardware and software medical device platform utilizing virtual reality technology designed for use in healthcare and focusing on physical and neuro rehabilitation. The use of the device is intended to be in a clinical environment supervised by a medical professional trained in rehabilitation therapy. The mode to test is in functional mode when the device is completely removed from the charging station and strapped to a patient.

The Real Immersive System is composed of:

- All-In-One Head Mounted Display (HMD)
- Wireless Sensor Modules (WSM)
- Wireless Transmitter Module (WTM)
- Dongles-Hub Module
- HMD Sensor Module
- Charger
- WiFi Router (tp-link TL-WR802N)
- Samsung Galaxy Tab S3

For more information, refer to the following product specification, declared by the manufacturer.

Information about the 2.4 GHz radio is presented below:

<b>Applicant</b>	Penumbra, Inc.
<b>Model No.</b>	Model 0
<b>FCC Identifier</b>	2AQU7-REAL00
<b>IC Identifier</b>	24199-REAL00
<b>Type of transmission</b>	Digital Transmission System (DTS)
<b>Rated RF Output</b>	0.65 dBm
<b>Antenna(s) &amp; Gain</b>	Internal Antenna, Peak Gain: -2.0 dBi
<b>Frequency Range</b>	2402 – 2479 MHz
<b>Type of modulation/data rate</b>	Frequency-shift Keying (FSK) / 2Mbit/s
<b>Number of Channel(s)</b>	18
<b>Applicant Name &amp; Address</b>	Penumbra, Inc. One Penumbra Place Alameda, CA 94502 USA

2.2 Related Submittal(s) Grants

None.

2.3 Test Facility

The test site used to collect the radiated data is site 1 (10-m semi-anechoic chamber). This test facility and site measurement data have been fully placed on file with the FCC, IC and A2LA accredited.

2.4 Test Methodology

Antenna conducted measurements were performed according to the FCC documents “Guidance for Performing Compliance Measurement on Digital Transmission Systems (DTS) Operating under §15.247” (KDB 558074 D01 DTS Meas Guidance v04), and RSS-247, RSS-GEN Issue 5.

Radiated emissions and AC mains conducted emissions measurements were performed according to the procedures in ANSI C63.10: 2013. Radiated tests were performed at an antenna to EUT distance of 3 meters, unless stated otherwise in the "Data Sheet" of this report.

2.5 Measurement Uncertainty

Compliance with the limits was based on the results of the measurements and doesn't take into account the measurement uncertainty.

Estimated Measurement Uncertainty

Measurement	Expanded Uncertainty (k=2)		
	0.15 MHz – 1 GHz	1 GHz – 2.5 GHz	> 2.5 GHz
RF Power and Power Density – antenna conducted	-	0.7 dB	-
Unwanted emissions - antenna conducted	1.1 dB	1.3 dB	1.9 dB
Bandwidth – antenna conducted	-	30 Hz	-

Measurement	Expanded Uncertainty (k=2)			
	0.15 MHz – 30MHz	30 – 200 MHz	200 MHz – 1 GHz	1 GHz – 18 GHz
Radiated emissions	-	4.7	4.6	5.1 dB
AC mains conducted emissions	2.1 dB	-	-	-

### 3.0 System Test Configuration

#### 3.1 Support Equipment

Support Equipment		
Description	Manufacturer	Model Number
Laptop	Dell	Latitude 5480
VR Headset with Remote	HTC	VIVE
Tablet	Samsung	Galaxy Tab 3

#### 3.2 Block Diagram of Test Setup

Equipment Under Test			
Description	Manufacturer	Part Number	Serial Number (LOT Number)
Radiated Sample of HMD, Head Mounted Display	Penumbra, Inc.	13767	089649_SW
Conducted Sample of HMD, Head Mounted Display	Penumbra, Inc.	13767	E08769

Antenna was removed and co-axial connector with a cable was installed for Conducted Measurements.

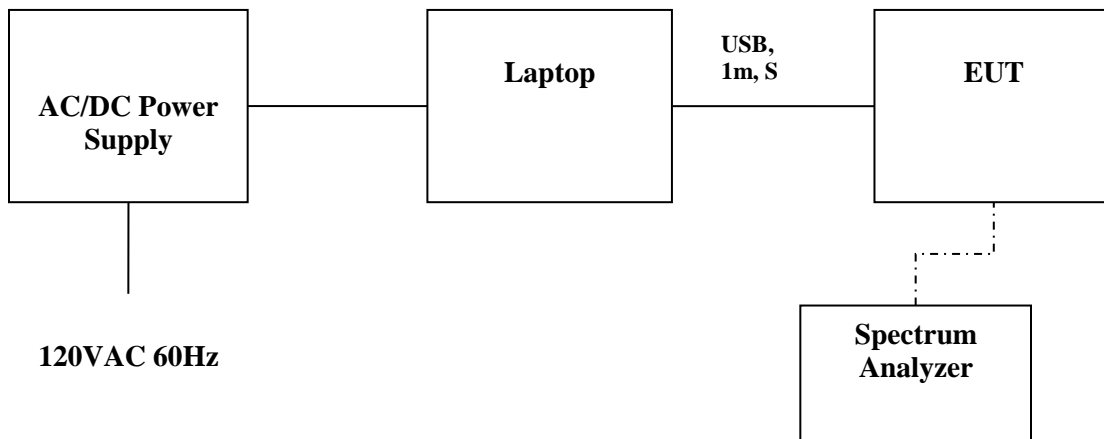

<b>S</b> = Shielded	<b>F</b> = With Ferrite
<b>U</b> = Unshielded	<b>m</b> = Length in Meters

### 3.3 Justification

For radiated emission measurements the EUT is placed on a non-conductive table.

According to the manufacturer, the WSM and WTM will be configured with one of the following channel configurations (20 – 25). Each Channel configuration will consist of 3 available frequencies. Each Real Immersive System will consist of 5 WSM and 1 WTM. The channels programmed into the system will not overlap. The 5 WSM and 1 WTM will be paired with 6 USB dongles inside the HMD.

Channel	F1	F2	F3
20	2402 MHz	2439 MHz	2469 MHz
21	2405 MHz	2444 MHz	2474 MHz
22	2410 MHz	2449 MHz	2479 MHz
23	2415 MHz	2454 MHz	2428 MHz
24	2420 MHz	2459 MHz	2431 MHz
25	2425 MHz	2464 MHz	2436 MHz

### 3.4 Software Exercise Program

The EUT exercise program used during radiated and conducted testing was provided by Penumbra, Inc.



### 3.5 Mode of Operation during Test

As instructed by the manufacturer, the EUT's power setting was set to 0 dBm on the low, middle and high frequencies/channels.

For radiated measurements the high channel one USB dongle was programmed to transmit at the low, mid or high channels. For low channel, the USB dongle was inserted in slot 20. For mid channel, USB dongle was inserted in slot 25. For high channel, USB dongle was inserted in slot 24. The rest of the USB ports were populated with normal working USB dongles and programmed to work as intended in normal operation in the assigned channels as in section 3.3.

Testing was also carried out with the HMD co-located with the HTC VR Headset and Remote. The HMD was set to transmit at low, mid and high setting alongside the VR Headset which was set to transmit at 2.4 GHz WIFI or 5 GHz WIFI. The VR Headset was also paired with the Remote via 2.4 GHz Bluetooth.

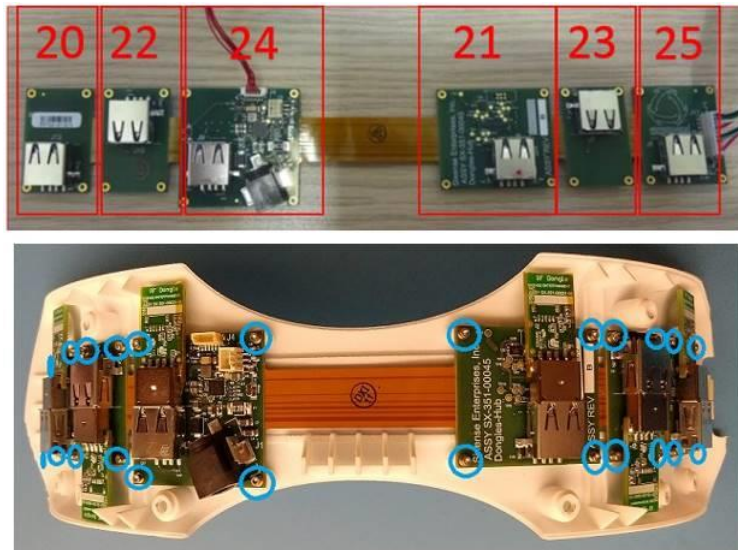

### 3.6 Modifications Required for Compliance

No modifications were made by the manufacturer or Intertek to the EUT in order to bring the EUT into compliance.

### 3.7 Additions, Deviations and Exclusions from Standards

No additions, deviations or exclusions from the standard were made.

**4.0 Measurement Results**

4.1 6-dB Bandwidth and 99% Occupied Bandwidth  
FCC Rule: 15.247(a)(2); RSS-247, 5.2.1 and RSS-GEN;

4.1.1 Requirement

The minimum 6-dB bandwidth shall be at least 500 kHz

4.1.2 Procedure

A spectrum analyzer was connected to the antenna port of the transmitter.

For FCC 6dB Channel Bandwidth the Procedure described in the FCC Publication 558074 D01 DTS Meas Guidance v04 was used to determine the DTS occupied bandwidth. Section 8.1 Option 1 was used.

1. Set RBW = 100 kHz.
2. Set the video bandwidth (VBW)  $\geq 3 \times$  RBW.
3. Detector = Peak.
4. Trace mode = max hold.
5. Sweep = auto couple.
6. Allow the trace to stabilize.
7. Measure the maximum width of the emission that is constrained by the frequencies associated with the two outermost amplitude points (upper and lower frequencies) that are attenuated by 6 dB relative to the maximum level measured in the fundamental emission.

For 99% power bandwidth measurement, the bandwidth was determined by using the built-in 99% occupied bandwidth function of the spectrum analyzer. The resolution bandwidth is set to 1% of the selected span as is without being below 1%. The video bandwidth shall be set to 3 times the resolution bandwidth.

4.1.3 Test Result

Frequency (MHz)	6-dB bandwidth FCC 15.247 & RSS-GEN	Occupied bandwidth, RSS-GEN	Plot
MHz	MHz	MHz	
2402	1.010	--	1.1
	--	1.968	1.4
2439	1.018	--	1.2
	--	1.918	1.5
2479	1.007	--	1.3
	--	2.010	1.6

Tested By	Test Date
Anderson Soungpanya	July 16, 2018

Plot 1. 1

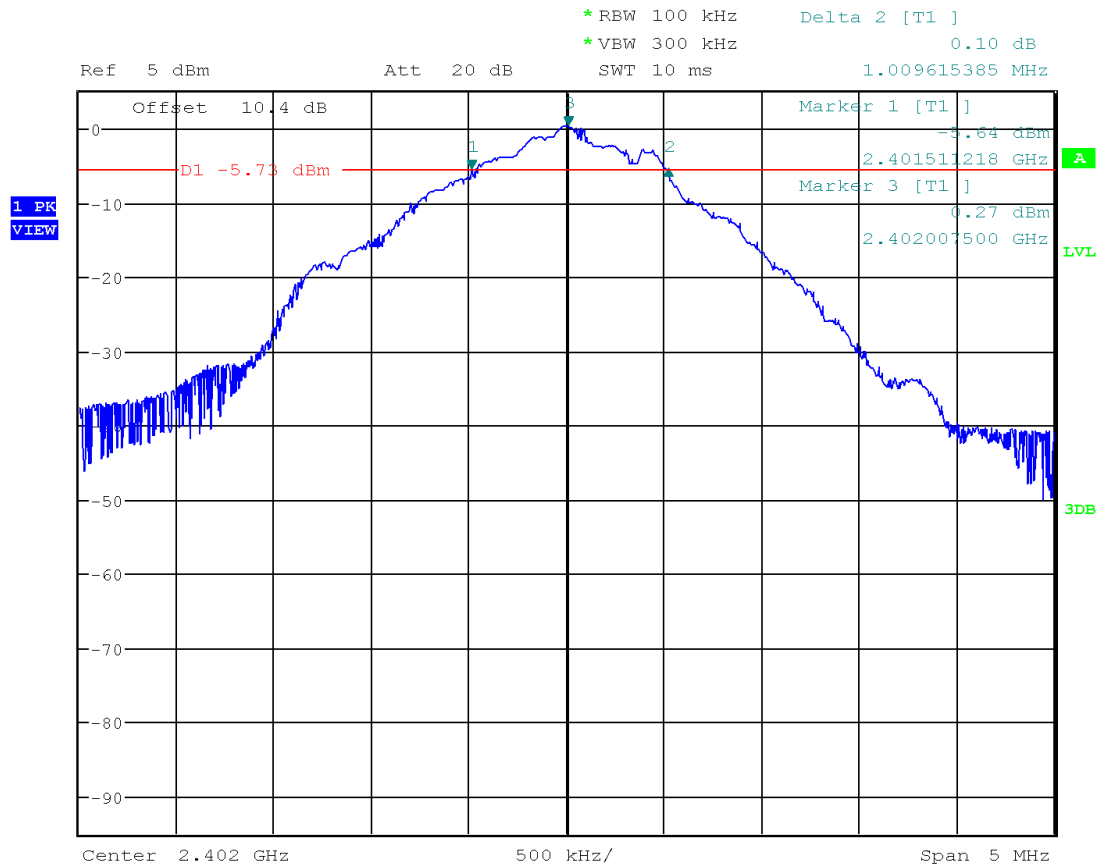

Date: 16.JUL.2018 11:50:44

Plot 1.2

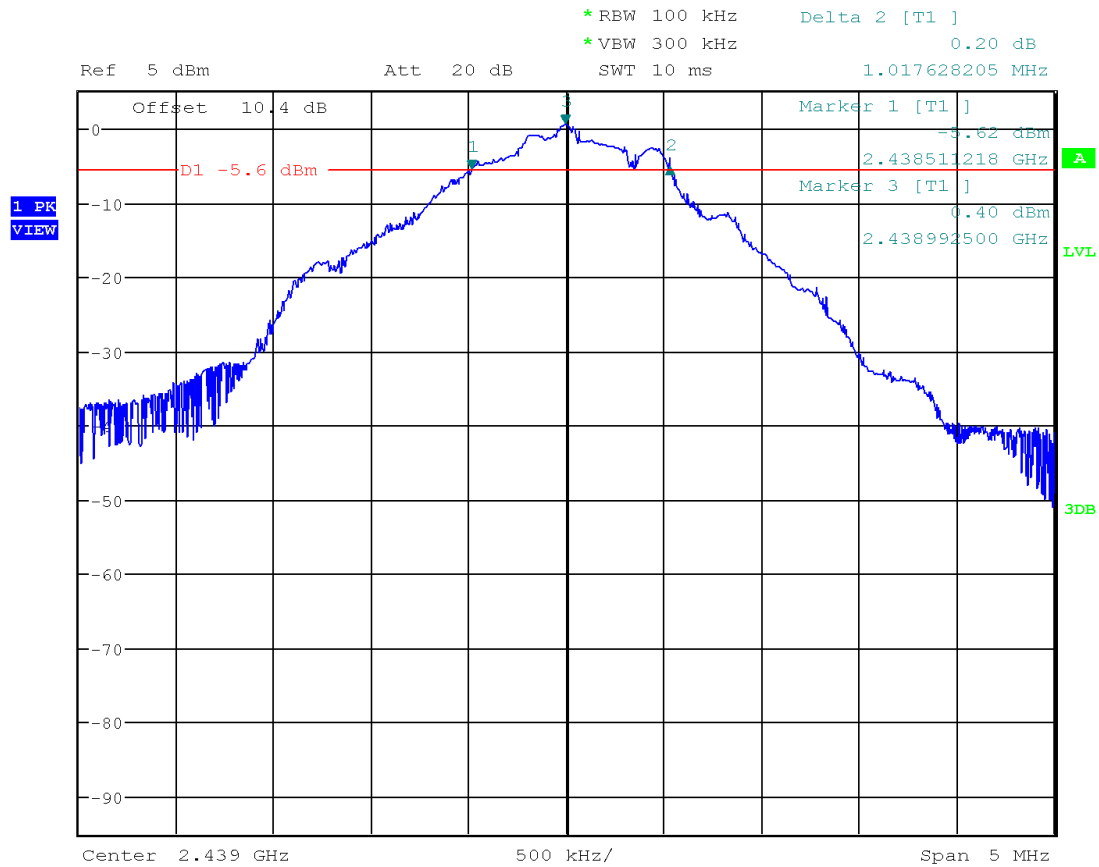

Date: 16.JUL.2018 11:48:43

Plot 1.3

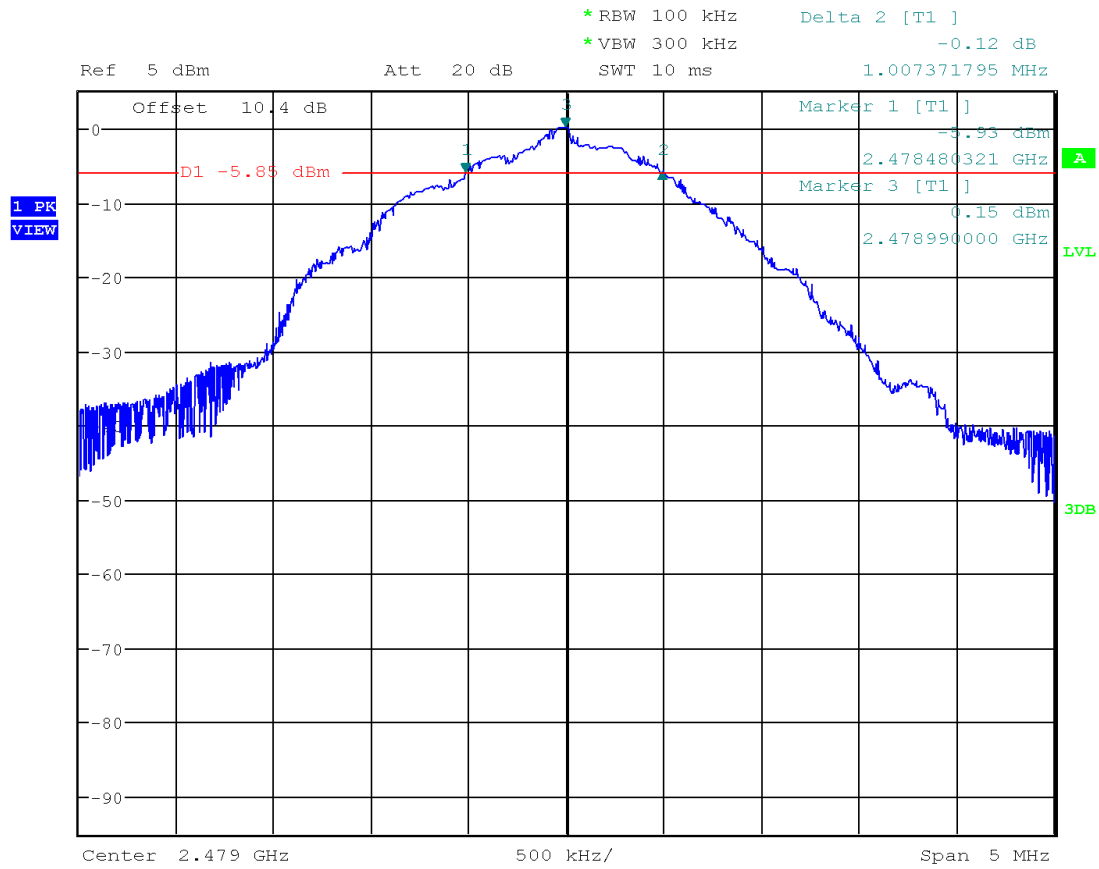

Date: 16.JUL.2018 11:47:11

Plot 1. 4

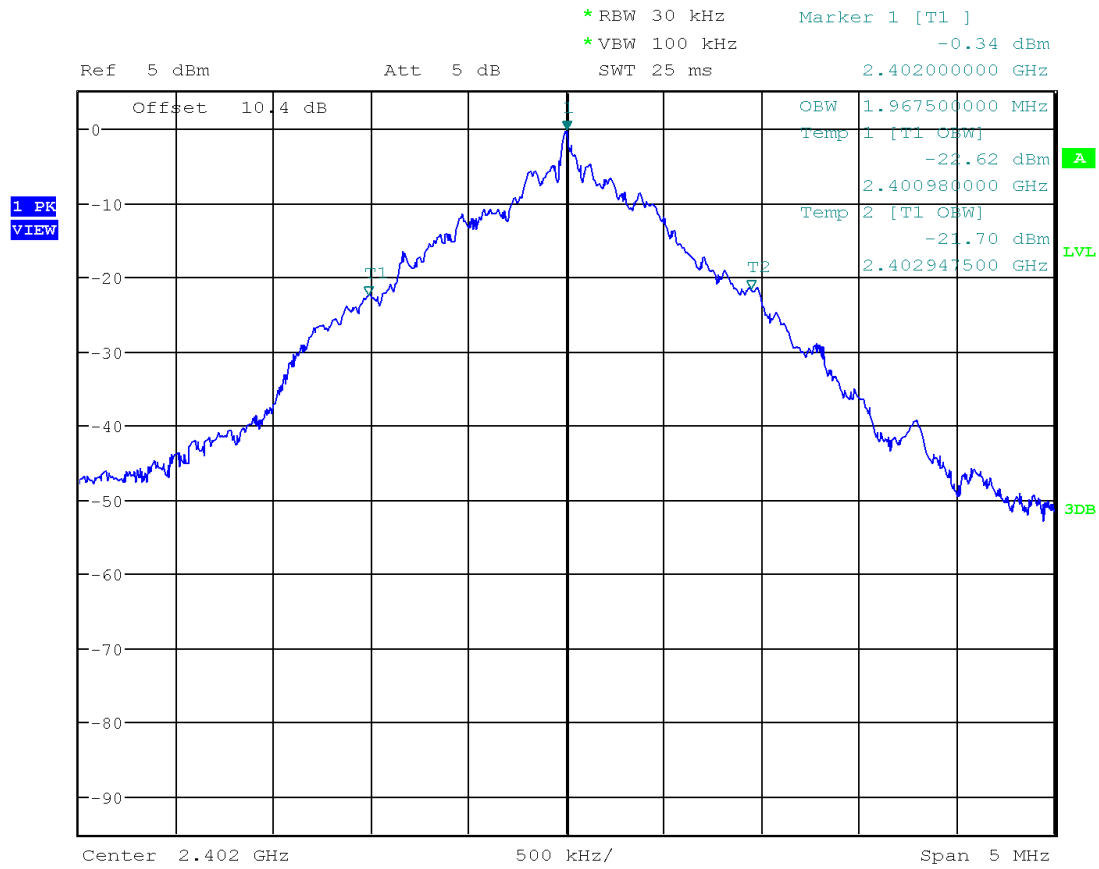

Date: 16.JUL.2018 11:52:42

Plot 1.5

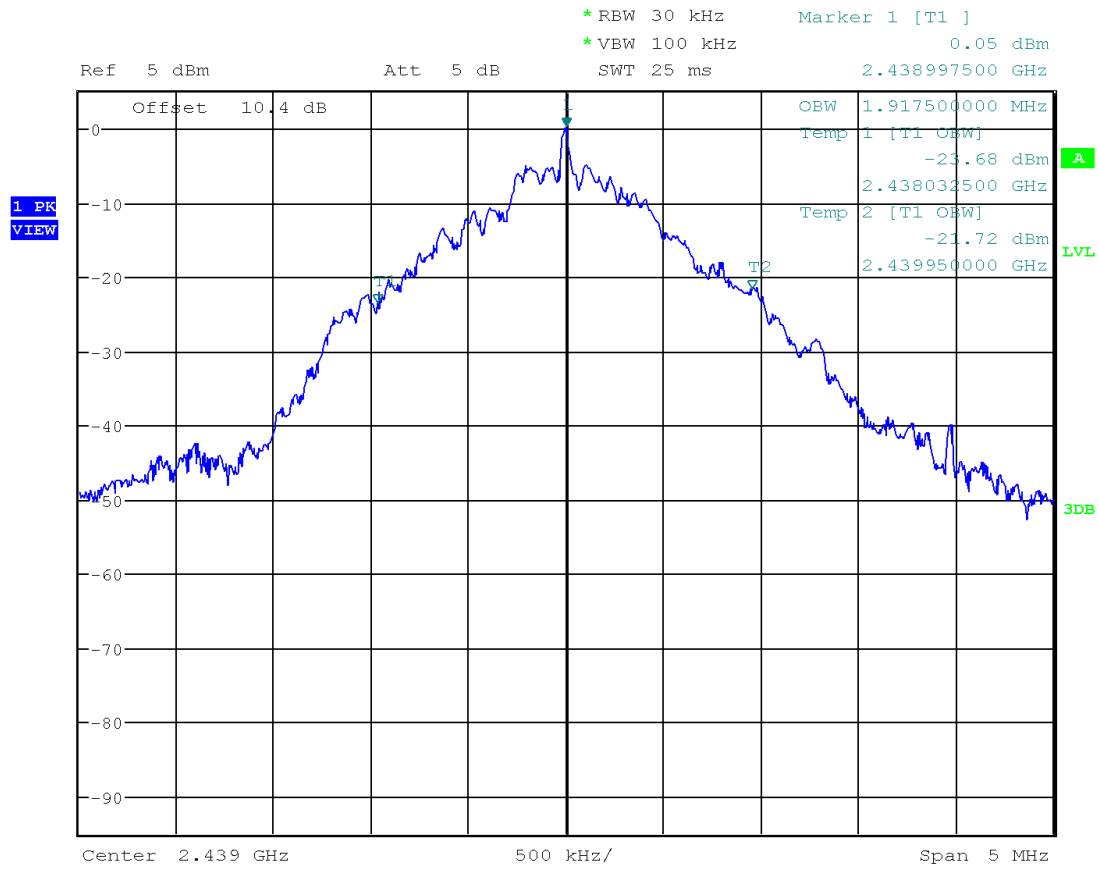

Date: 16.JUL.2018 11:53:48

Plot 1.6

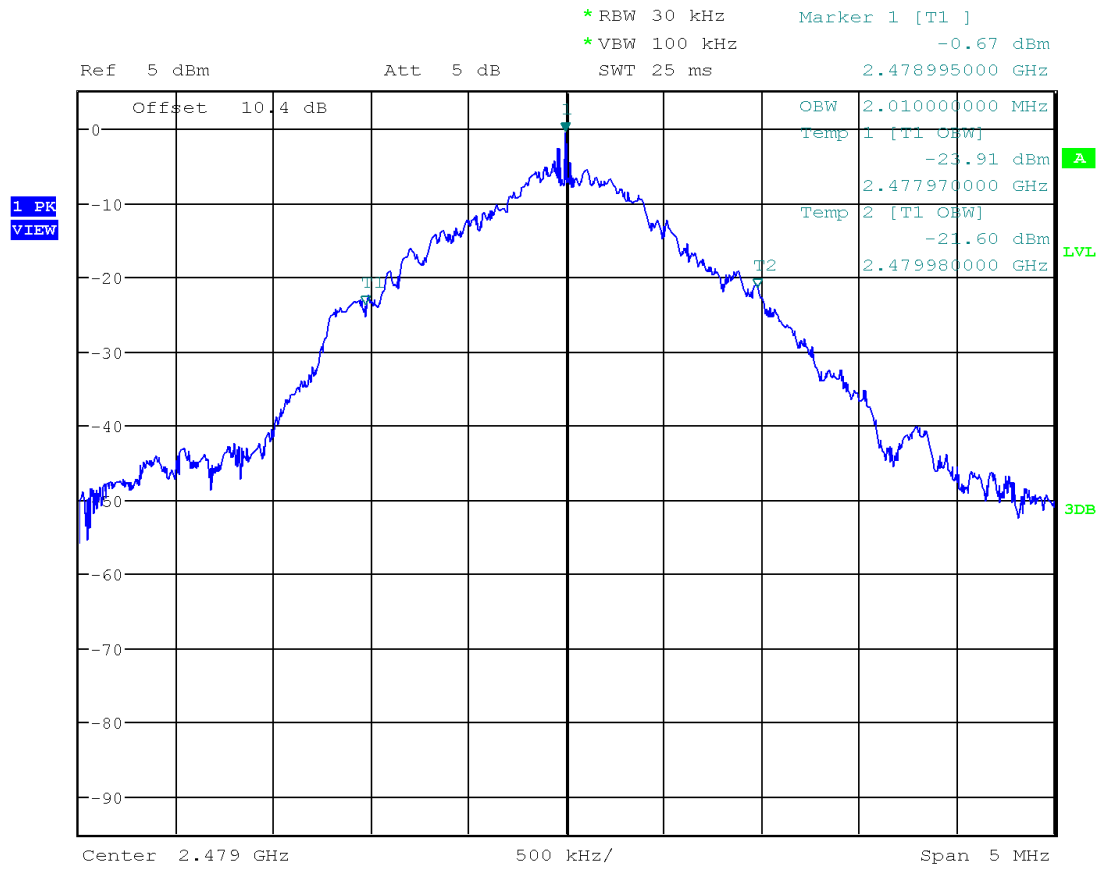

Date: 16.JUL.2018 11:55:15



4.2 Maximum Peak Conducted Output Power at Antenna Terminals  
FCC Rule: 15.247(b)(3); RSS-247, 5.4.4;

4.2.1 Requirement

For antennas with gains of 6 dBi or less, maximum allowed transmitter output is 1 watt or 30 dBm. For antennas with gains greater than 6 dBi, transmitter output level must be decreased appropriately, by the amount in dB that the directional gain of the antenna exceeds 6 dBi.

4.2.2 Procedure

The procedure described in FCC Publication 558074 D01 DTS Meas Guidance v04 was used. Specifically, section 9.1.1 RBW ≥ DTS Bandwidth was utilized as the spectrum analyzer’s resolution bandwidth was greater than the DTS bandwidth.

1. Set the RBW ≥ DTS Bandwidth
2. Set the VBW ≥ 3 x RBW
3. Set the span ≥ 3 x RBW
4. Detector = Peak
5. Sweep time = Auto couple
6. Trace mode = Max Hold
7. Allow trace to fully stabilize
8. Use peak marker function to determine the peak amplitude level.

A spectrum analyzer was connected to the antenna port of the transmitter.

4.2.3 Test Result

Refer to the following plots 2.1 – 2.3 for the test details.

Frequency, MHz	Conducted Power (peak)	Conducted Power (peak)	Plot
	dBm	mW	
2402	0.55	1.135	2.1
2439	0.65	1.161	2.2
2479	0.38	1.091	2.3

Tested By	Test Date
Anderson Soungpanya	July 16, 2018

Plot 2. 1

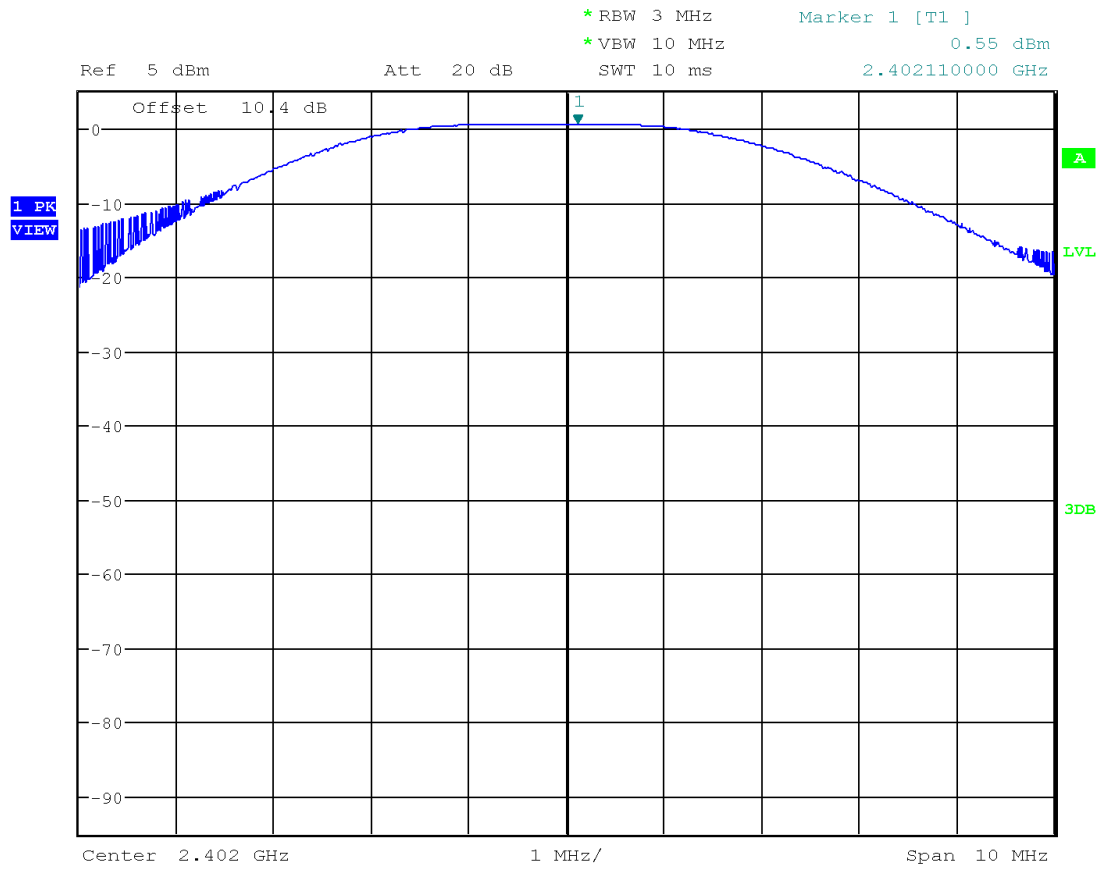

Date: 16.JUL.2018 11:42:11

Plot 2.2

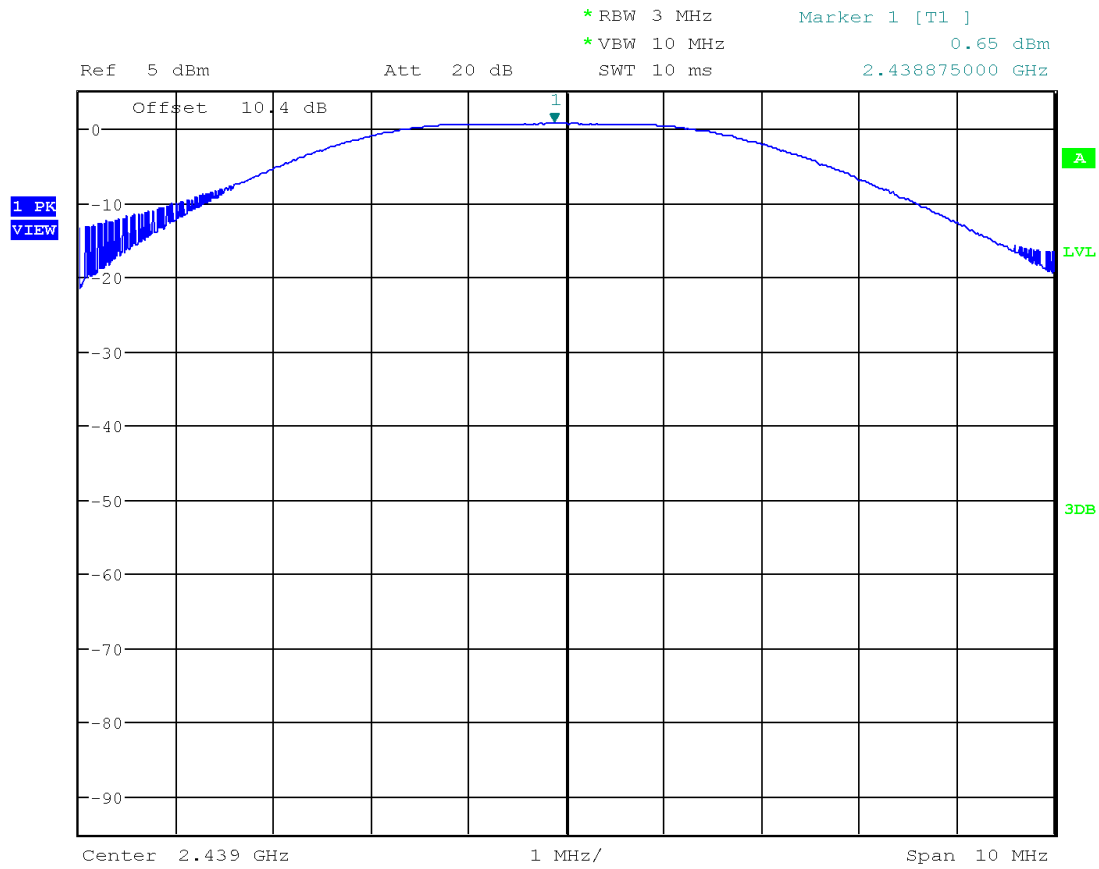

Date: 16.JUL.2018 11:41:22

*Plot 2.3*

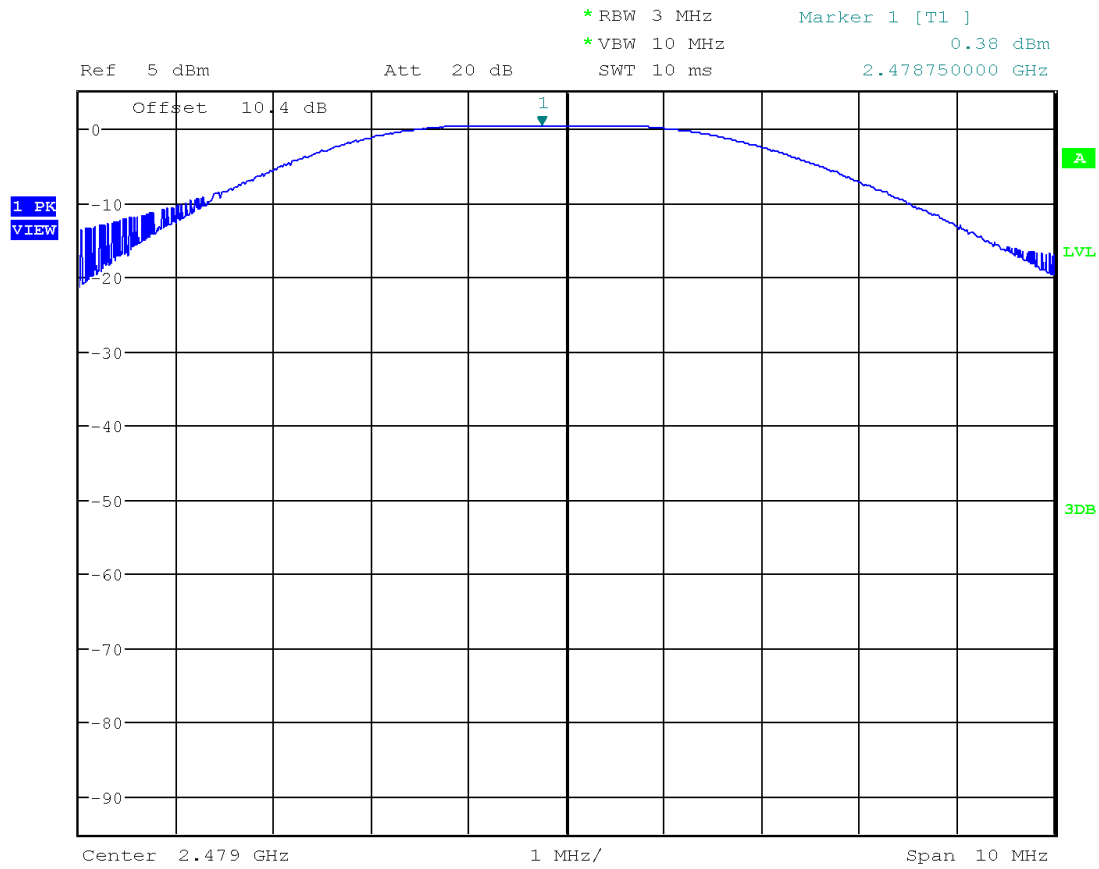

Date: 16.JUL.2018 11:39:51

4.3 Maximum Power Spectral Density  
FCC: 15.247 (e); RSS-247, 5.2.2;

4.3.1 Requirement

For digitally modulated systems, the power spectral density conducted from the intentional radiator to the antenna should not be greater than 8 dBm in any 3 kHz band during any time interval of continuous transmission.

4.3.2 Procedure

A spectrum analyzer was connected to the antenna port of the transmitter.

The procedure described in FCC Publication 558074 D01 DTS Meas Guidance v04, specifically section 10.2 Method PKPSD (peak PSD).

1. Set analyzer center frequency to DTS channel center frequency.
2. Set the span to 1.5 times the *DTS bandwidth*.
3. Set the RBW to:  $3 \text{ kHz} \leq \text{RBW} \leq 100 \text{ kHz}$ .
4. Set the VBW  $\geq 3 \times \text{RBW}$ .
5. Detector = peak.
6. Sweep time = auto couple.
7. Trace mode = max hold.
8. Allow trace to fully stabilize.
9. Use the peak marker function to determine the maximum amplitude level within the RBW.
10. If measured value exceeds limit, reduce RBW (no less than 3 kHz) and repeat.

4.3.3 Test Result

Refer to the following plots for the test result

Frequency	Maximum Power Spectral Density	Maximum Power Spectral Density Limit	Margin	Plot
MHz	dBm	dBm	dB	
2402	0.34	8.0	-7.66	3.1
2439	0.44	8.0	-7.56	3.2
2479	0.16	8.0	-7.84	3.3

Tested By	Test Date
Anderson Soungpanya	July 16, 2018

Plot 3.1

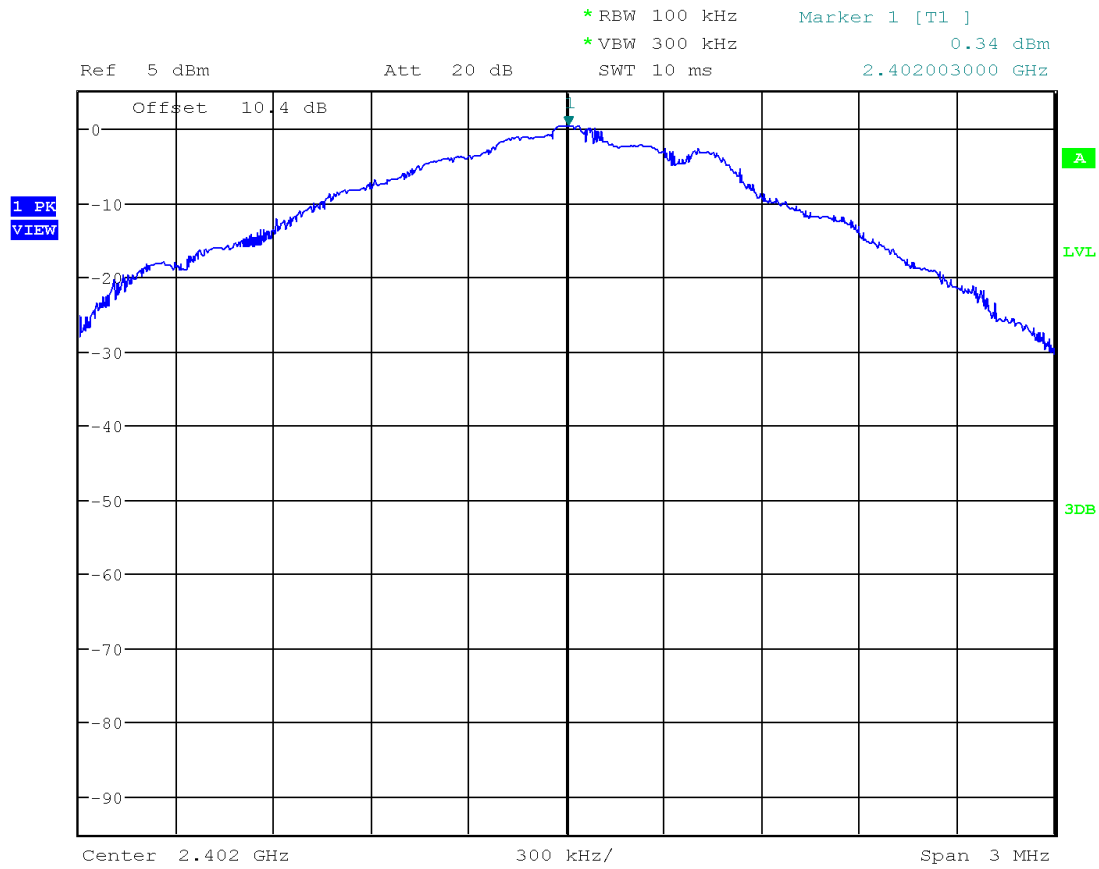

Date: 16.JUL.2018 11:43:19

Plot 3.2

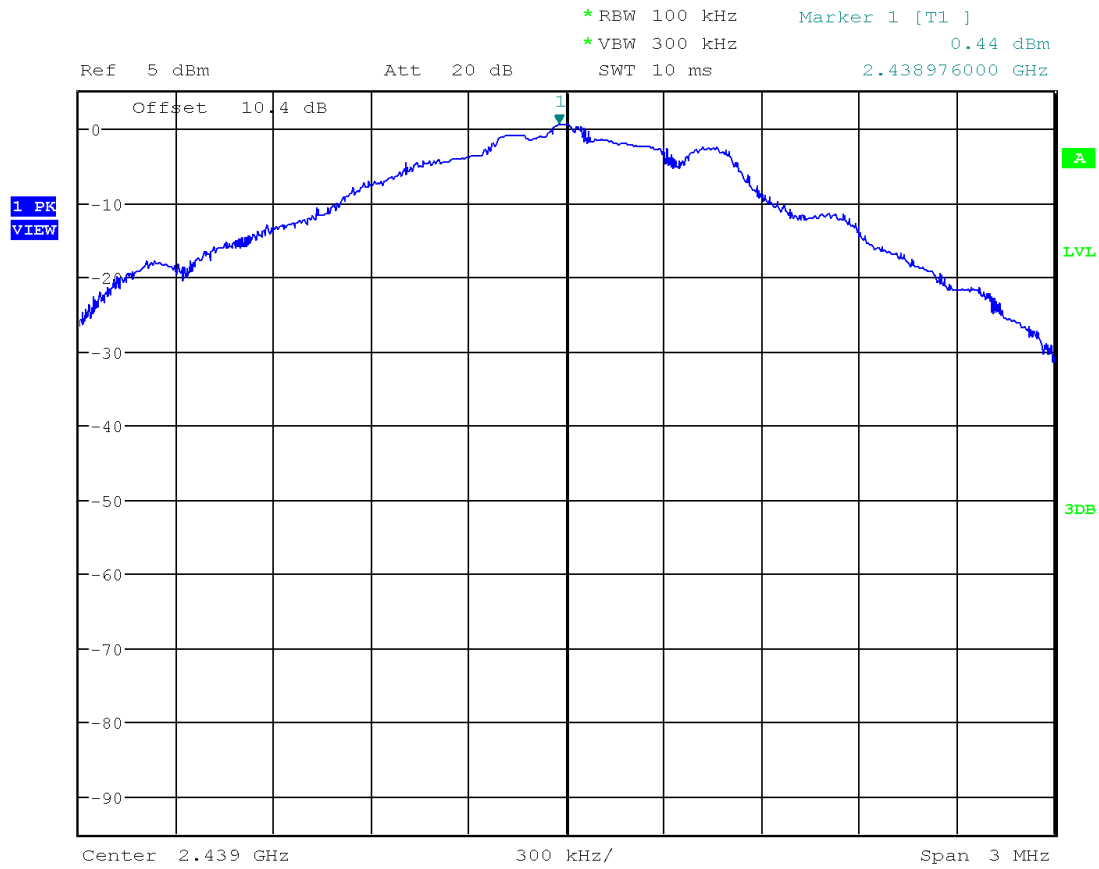

Date: 16.JUL.2018 11:44:14

Plot 3.3

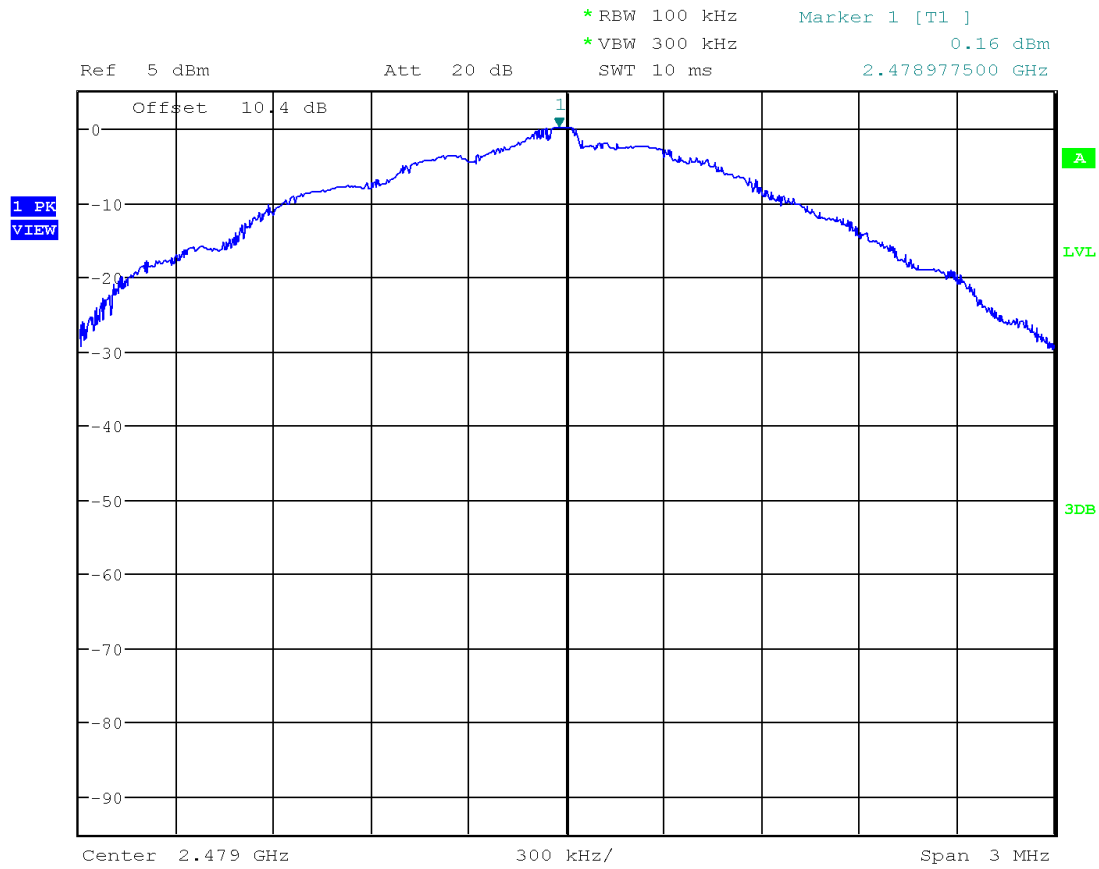

Date: 16.JUL.2018 11:45:15



4.4 Out of Band Antenna Conducted Emission  
FCC: 15.247(d); RSS-247, 5.5;

4.4.1 Requirement

In any 100 kHz bandwidth outside the EUT pass-band, the RF power shall be below the maximum in-band 100 kHz emissions by at least 20 dB (if peak power of in-band emission is measured) or 30 dB (if average power of in-band emission is measured).

In addition, radiated emissions which fall in the restricted bands, as defined in § 15.205(a), must also comply with the radiated emission limits specified in § 15.209(a)

4.4.2 Procedure

The procedure described in FCC Publication 558074 D01 DTS Meas Guidance v04, specifically section 11.0 Emissions in non-restricted frequency bands.

A spectrum analyzer was connected to the antenna port of the transmitter.

1. Set the RBW = 100 kHz.
2. Set the VBW  $\geq 3 \times$  RBW.
3. Detector = peak.
4. Sweep time = auto couple.
5. Trace mode = max hold.
6. Allow trace to fully stabilize.
7. Use the peak marker function to determine the maximum amplitude level.

The unwanted emissions were measured from 30 MHz to 25 GHz. Plots below are corrected for cable loss and then compared to the limits.

4.4.3 Test Result

Refer to the following plots 4.1 – 4.5 for unwanted conducted emissions. The plot shows -20dB attenuation limit line.

Tested By	Test Date
Anderson Soungpanya	July 16, 2018

Tx @ Low Channel, 2400 MHz Band Edge  
Plot 4.1

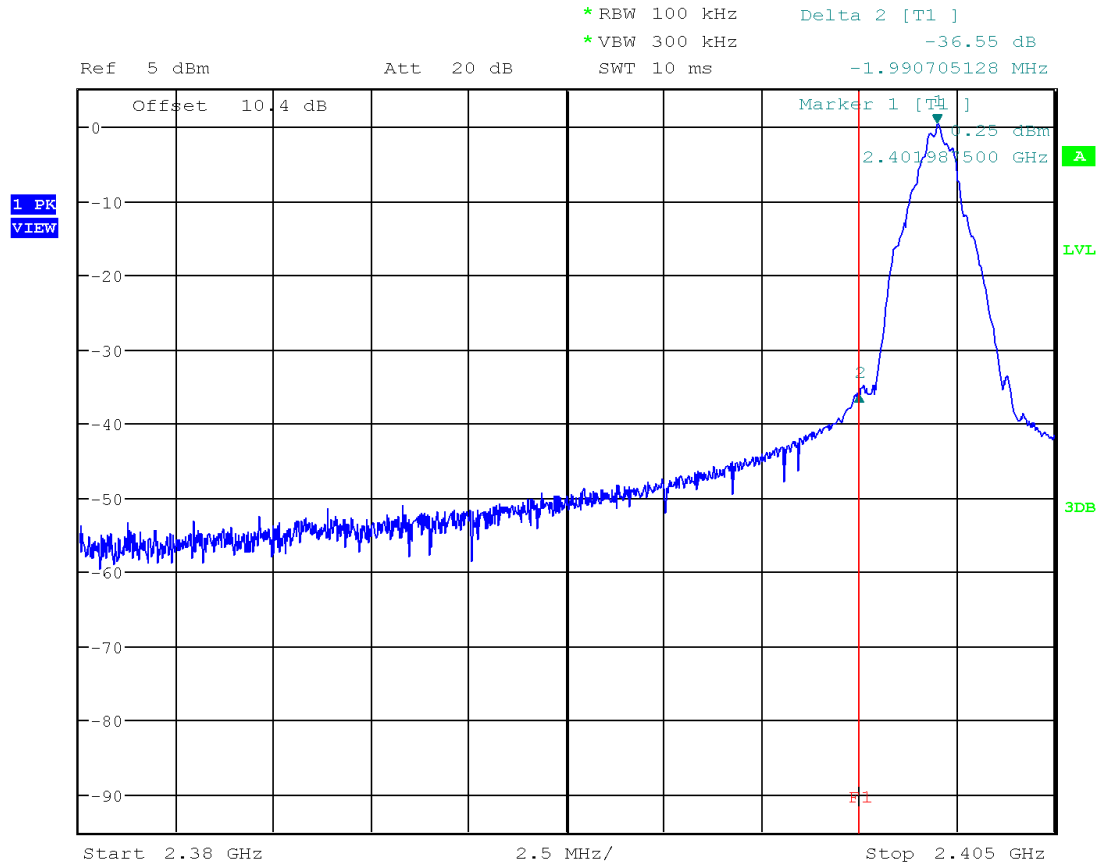

Date: 16.JUL.2018 12:06:40

Tx @ Low Channel, 2483.5 MHz Band Edge  
Plot 4.2

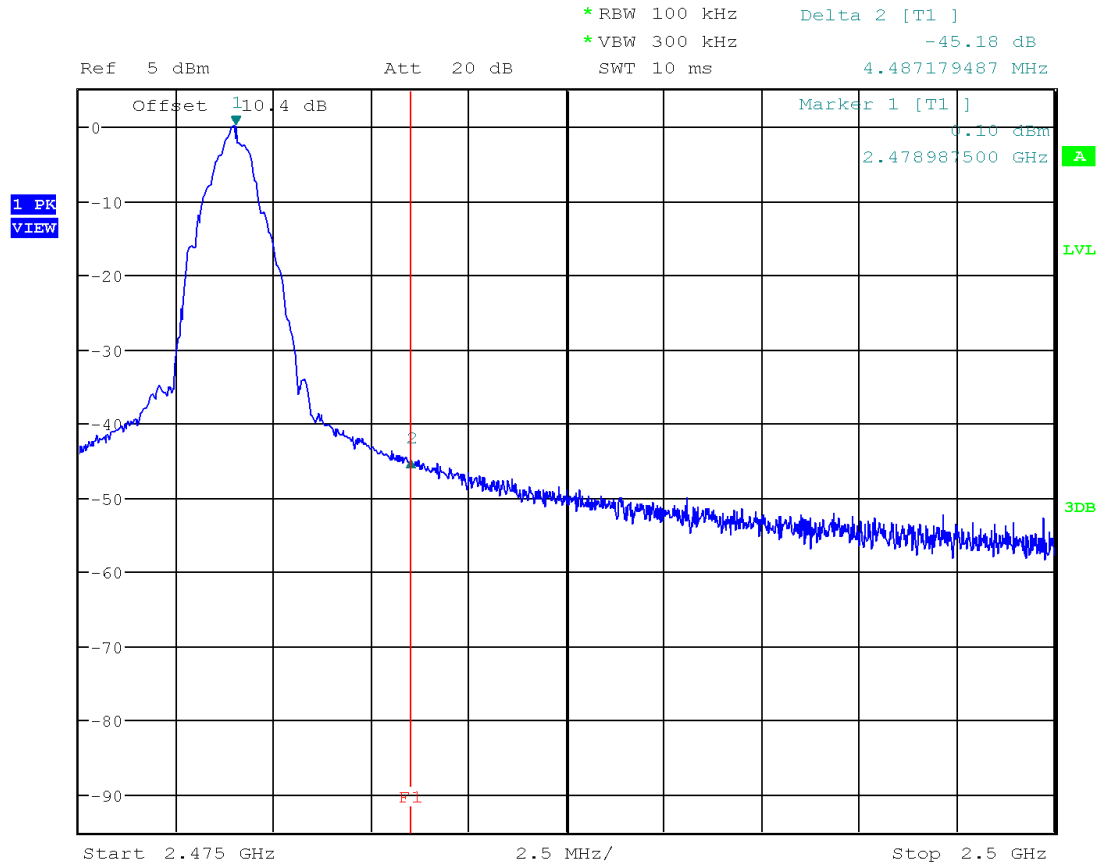

Date: 16.JUL.2018 12:01:52

Tx @ Low Channel, 2402 MHz  
30MHz -26GHz Conducted Spurious  
Plot 4.3

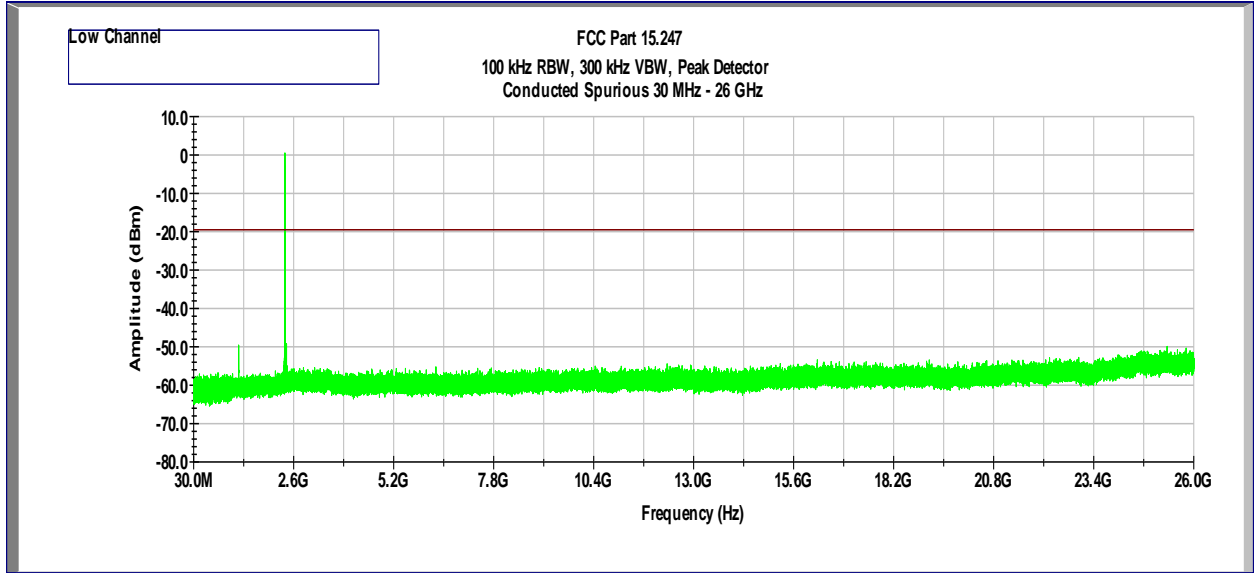

Tx @ Mid Channel, 2439 MHz  
30MHz -26GHz Conducted Spurious  
Plot 4.4

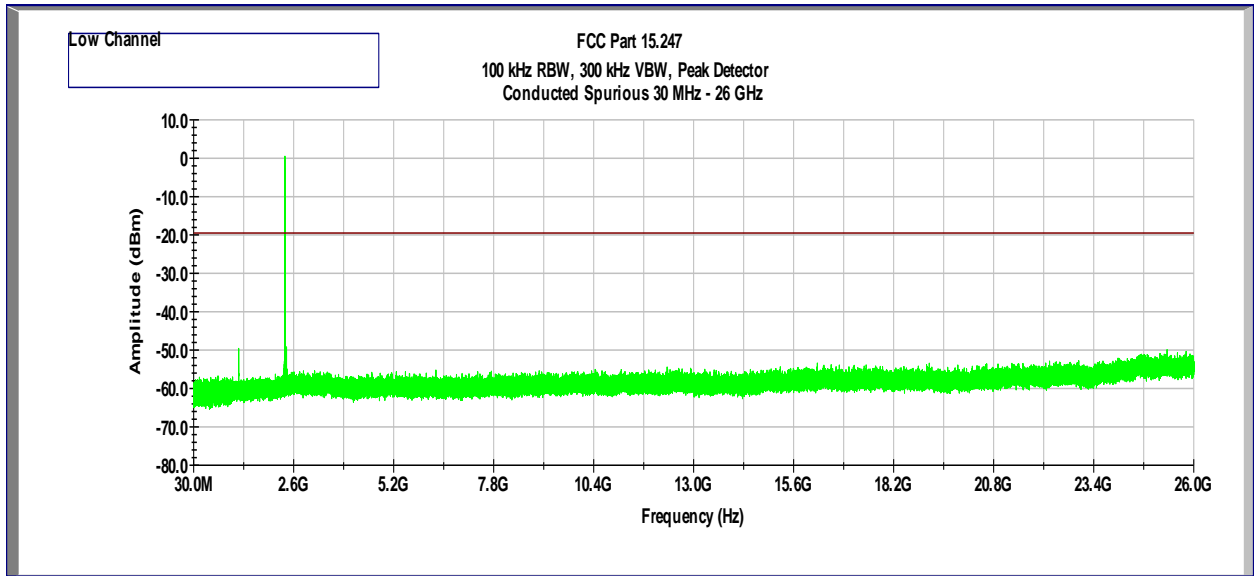

Tx @ High Channel, 2479 MHz  
30MHz -26GHz Conducted Spurious  
Plot 4.5

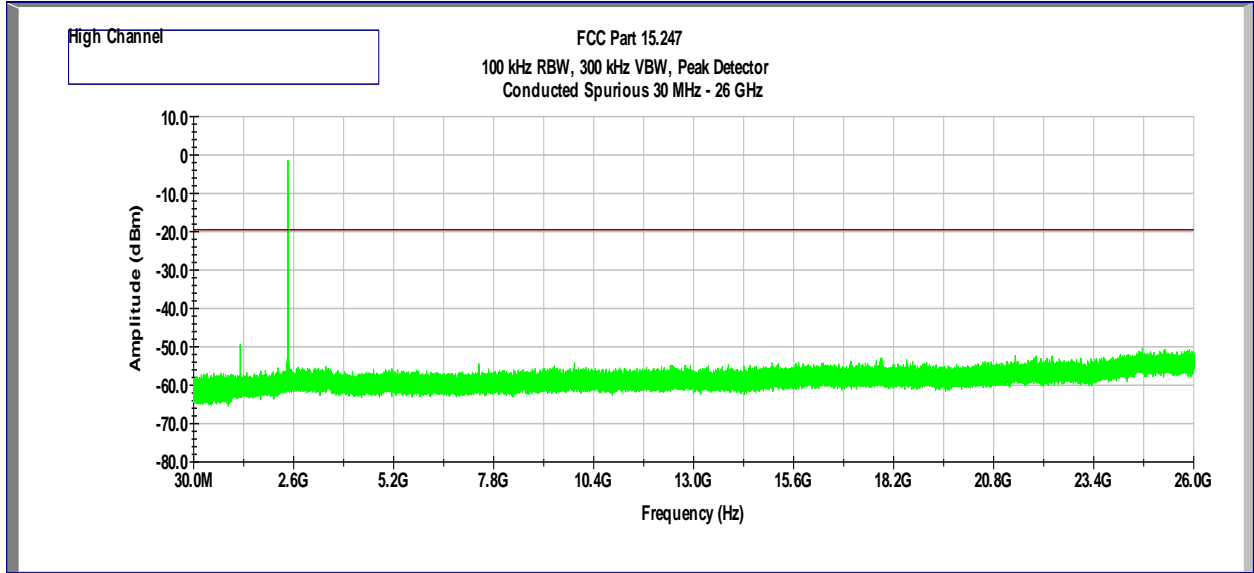

4.5 Transmitter Radiated Emissions  
FCC Rules: 15.247(d), 15.209, 15.205; RSS-247, 5.5;

4.5.1 Requirement

Radiated emissions which fall in the restricted bands, as defined in §15.205(a), must also comply with the radiated emission limits specified in §15.209(a) (see §15.205(c)).

For out of band radiated emissions (except for frequencies in restricted bands), in any 100 kHz bandwidths outside the EUT pass-band, the RF power shall be at least 20dB (peak) or 30 dB (average) below that of the maximum in-band 100 kHz emissions.

4.5.2 Procedure

Radiated emission measurements were performed from 30 MHz to 25 GHz according to the procedure described in ANSI C63.10: 2013. Spectrum Analyzer Resolution Bandwidth is 100 kHz or greater for frequencies 30 MHz to 1000 MHz, 1 MHz for frequencies above 1000 MHz. Above 1000 MHz Peak and Average measurements were performed.

The EUT is placed on a plastic turntable that is 80 cm in height for below 1000MHz and 1.5m in height for above 1GHz. If the EUT attaches to peripherals, they are connected and operational (as typical as possible). During testing, all cables were manipulated to produce worst-case emissions. The signal is maximized through rotation. The antenna height and polarization are varied during the search for maximum signal level. The antenna height is varied from 1 to 4 meters.

Radiated emissions are taken at 3 meters for frequencies above 1 GHz and at 10 meters for frequencies below 1 GHz.

Measurements made from 1 GHz to 18GHz had a 2.4 GHz or with 2.4GHz & 5.8 GHz notch filter in place. A preamp was used from 30MHz to 26GHz.

All measurements were made with a Peak Detector and compared to QP limits for 30MHz – 1GHz and Average limits for 1GHz – 26GHz.

Testing was also carried out with the HMD co-located with the HTC VR Headset and Remote. The HMD was set to transmit at low, mid and high setting along side the VR Headset which was set to transmit at 2.4 GHz WIFI or 5 GHz WIFI. The VR Headset was also paired with the Remote via 2.4 GHz Bluetooth.

Radiated measurements were performed on the X, Y and Z orientation of the EUT. Data is presented with the worst-case configuration (the configuration which resulted in the highest emission levels).

### 4.5.3 Field Strength Calculation

#### Field Strength Calculation

The field strength is calculated by adding the Antenna Factor and Cable Factor and subtracting the Amplifier Gain (if any) from the measured reading. The basic equation with a sample calculation is as follows:

$FS = RA + AF + CF - AG$ ; if measurement is performed at a distance other than specified in the rule, a Distance Correction Factor (DCF) shall be added.

Where FS = Field Strength in dB( $\mu$ V/m)

RA = Receiver Amplitude (including preamplifier) in dB( $\mu$ V); AF = Antenna Factor in dB(1/m)

CF = Cable Attenuation Factor in dB; AG = Amplifier Gain in dB

Assume a receiver reading of 52.0 dB( $\mu$ V) is obtained. The antennas factor of 7.4 dB(1/m) and cable factor of 1.6 dB is added. The amplifier gain of 29 dB is subtracted, giving field strength of 32 dB( $\mu$ V/m). This value in dB( $\mu$ V/m) was converted to its corresponding level in  $\mu$ V/m.

RA = 52.0 dB( $\mu$ V)

AF = 7.4 dB(1/m)

CF = 1.6 dB

AG = 29.0 dB

FS =  $52.0 + 7.4 + 1.6 - 29.0 = 32$  dB( $\mu$ V/m).

Level in  $\mu$ V/m = Common Antilogarithm [ $(32 \text{ dB}\mu\text{V/m})/20$ ] = 39.8  $\mu$ V/m.

#### 4.5.4 Antenna-port conducted measurements

Antenna-port conducted measurements may also be used as an alternative to radiated measurements for demonstrating compliance in the restricted frequency bands. If conducted measurements are performed, then proper impedance matching must be ensured and an additional radiated test for cabinet/case spurious emissions is required.

#### 4.5.5 General Procedure for conducted measurements in restricted bands

a) Measure the conducted output power (in dBm) using the detector specified for determining quasi-peak, peak, and average conducted output power, respectively.

b) Add the maximum transmit antenna gain (in dBi) to the measured output power level to determine the EIRP level (see 12.2.5 for guidance on determining the applicable antenna gain)

c) Add the appropriate maximum ground reflection factor to the EIRP level (6 dB for frequencies  $\leq 30$  MHz, 4.7 dB for frequencies between 30 MHz and 1000 MHz, inclusive and 0 dB for frequencies  $> 1000$  MHz).

d) For devices with multiple antenna-ports, measure the power of each individual chain and sum the EIRP of all chains in linear terms (*e.g.*, Watts, mW).

e) Convert the resultant EIRP level to an equivalent electric field strength using the following relationship:

$$E = \text{EIRP} - 20\log D + 104.8 + \text{DCF} \quad (\text{DCF for Average measurements})$$

where:

E = electric field strength in dB $\mu$ V/m,

EIRP = equivalent isotropic radiated power in dBm

D = specified measurement distance in meters.

DCF = Duty Cycle Correction Factor

f) Compare the resultant electric field strength level to the applicable limit.

g) Perform radiated spurious emission test

#### 4.5.6 Test Results

All testing in this section were performed by radiated measurements.

Tested By	Test Date
Anderson Soungpanya	July 06 - 17, 2018



**Test Results: 15.209/15.205 Radiated Restricted Band Emissions**

Out-of-Band Spurious Emissions at the Band Edge – Tx @ 2402 MHz, Average

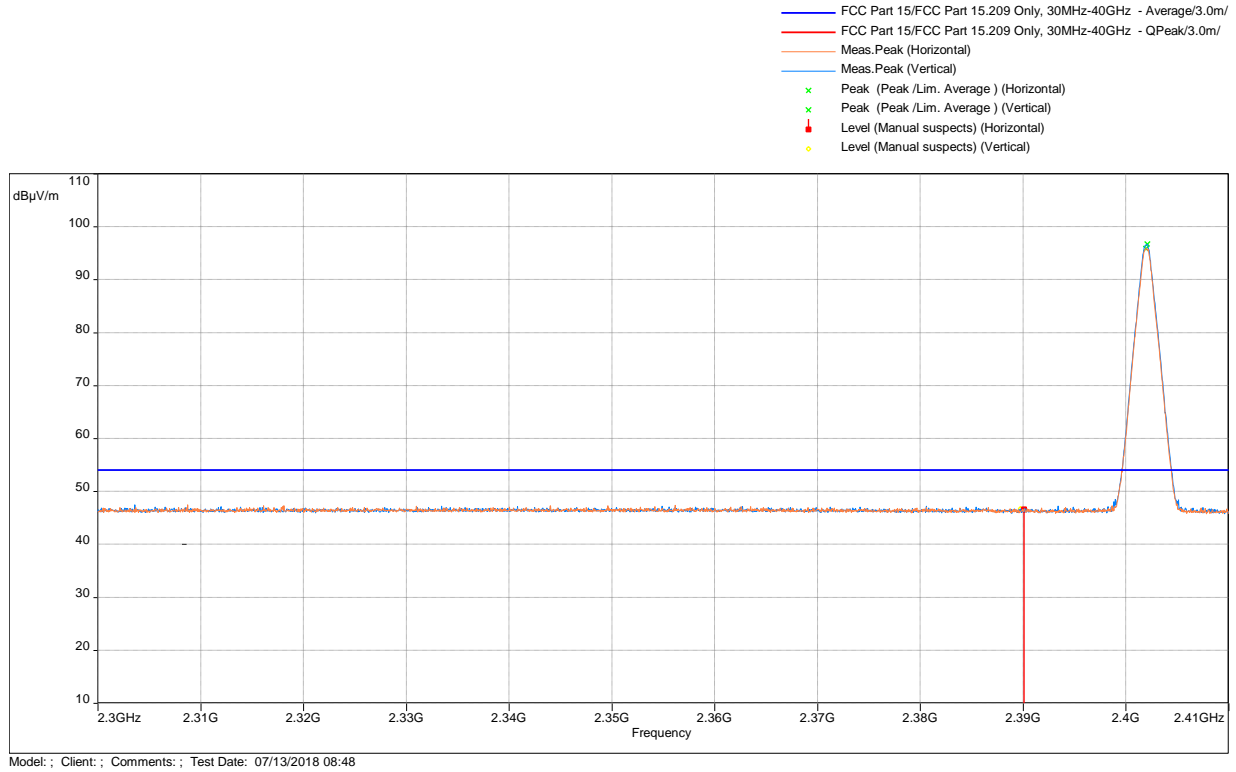

Frequency	Corrected Amplitude	Limit	Margin	Detector	Results
GHz	dBµV/m	dBµV/m	dB		
2.390	46.66	54	-7.34	RMS	Pass

Out-of-Band Spurious Emissions at the Band Edge – Tx @ 2402 MHz, Peak

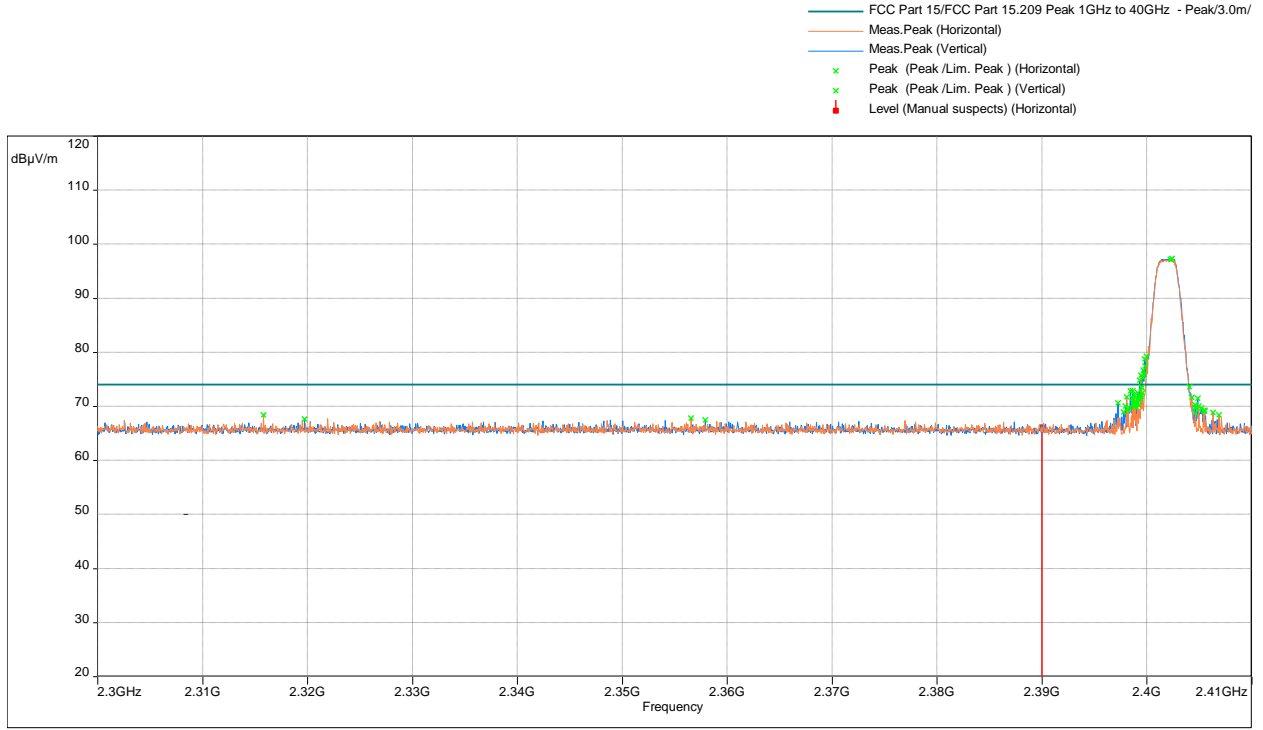

Frequency	Corrected Amplitude	Limit	Margin	Detector	Results
GHz	dBµV/m	dBµV/m	dB		
2.390	66.06	74	-7.94	Peak	Pass

Out-of-Band Spurious Emissions at the Band Edge – Tx @ 2479 MHz, Average

- FCC Part 15/FCC Part 15.209 Only, 30MHz-40GHz - Average/3.0m/
- FCC Part 15/FCC Part 15.209 Only, 30MHz-40GHz - QPeak/3.0m/
- Meas.Peak (Horizontal)
- Meas.Peak (Vertical)
- x Peak (Peak /Lim. Average ) (Horizontal)
- x Peak (Peak /Lim. Average ) (Vertical)
- ↓ Level (Manual suspects) (Horizontal)

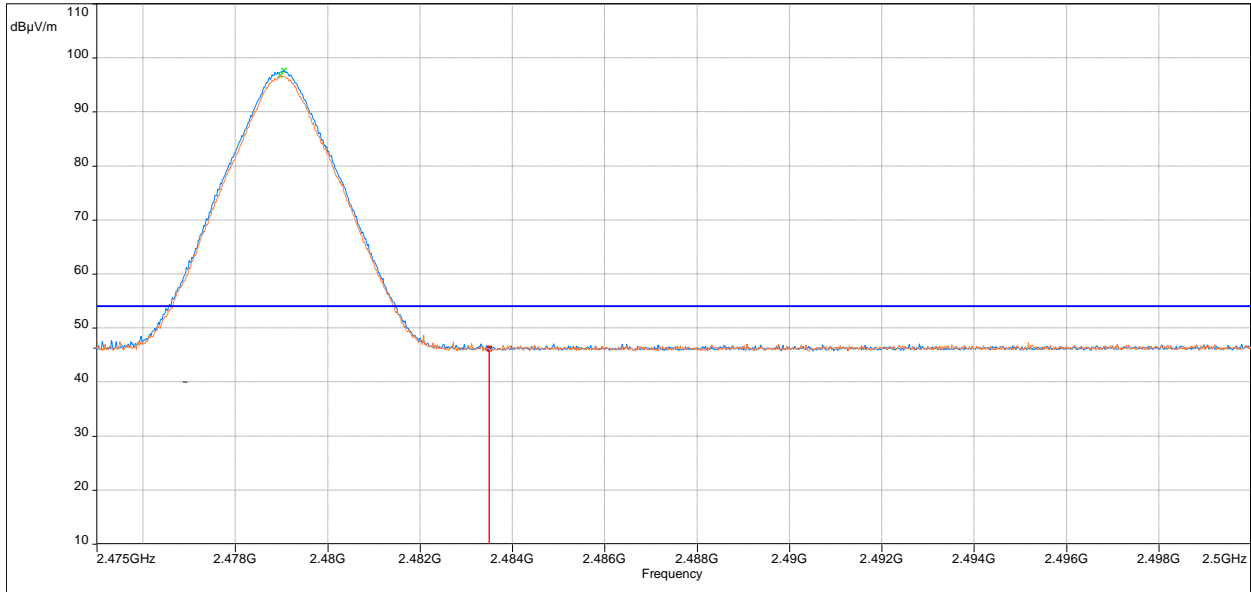

Model: ; Client: ; Comments: ; Test Date: 07/17/2018 09:59

Frequency	Corrected Amplitude	Limit	Margin	Detector	Results
GHz	dBµV/m	dBµV/m	dB		
2.4835	46.21	54	-7.79	RMS	Pass

Out-of-Band Spurious Emissions at the Band Edge – Tx @ 2479 MHz, Peak

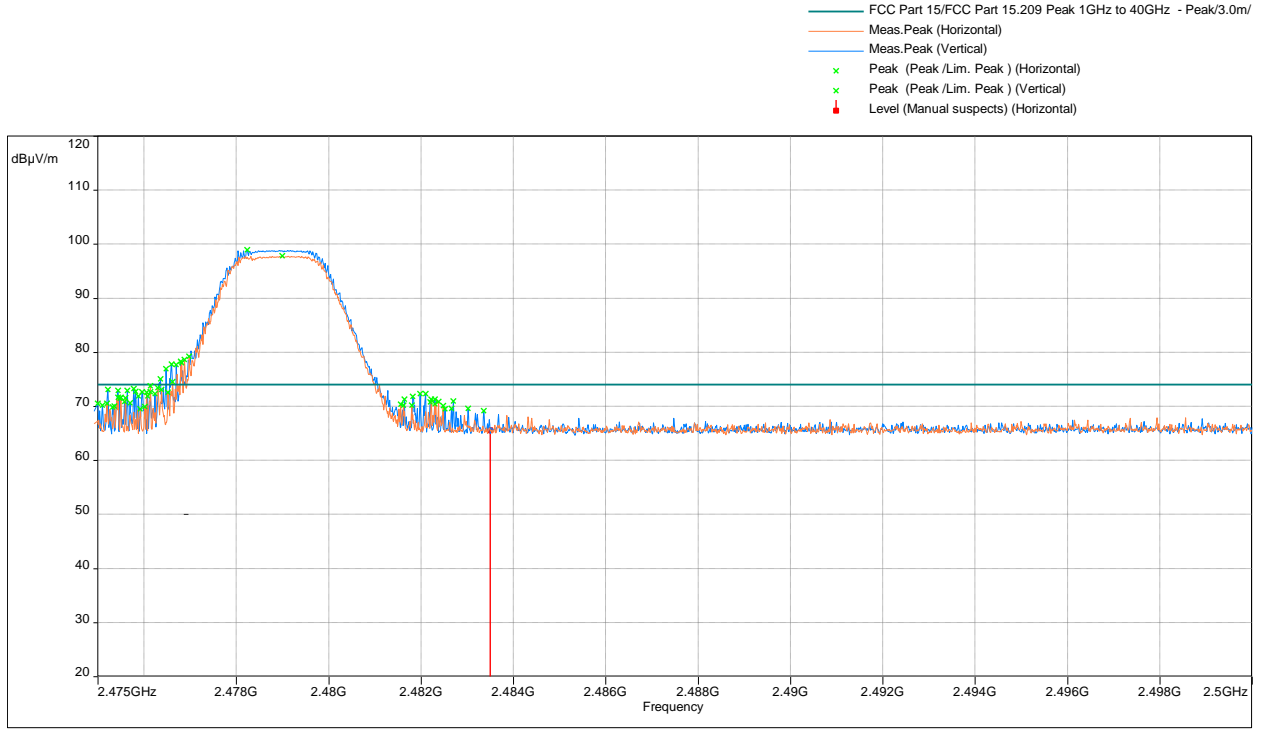

Frequency	Corrected Amplitude	Limit	Margin	Detector	Results
GHz	dBµV/m	dBµV/m	dB		
2.4835	65.57	74	-8.43	Peak	Pass

**Out-of-Band Radiated Spurious Emissions**

Test Results: 15.209 Radiated Spurious Emissions Low Channel, Tx at 2402MHz

**Radiated Spurious Emissions 30 MHz - 1000 MHz**

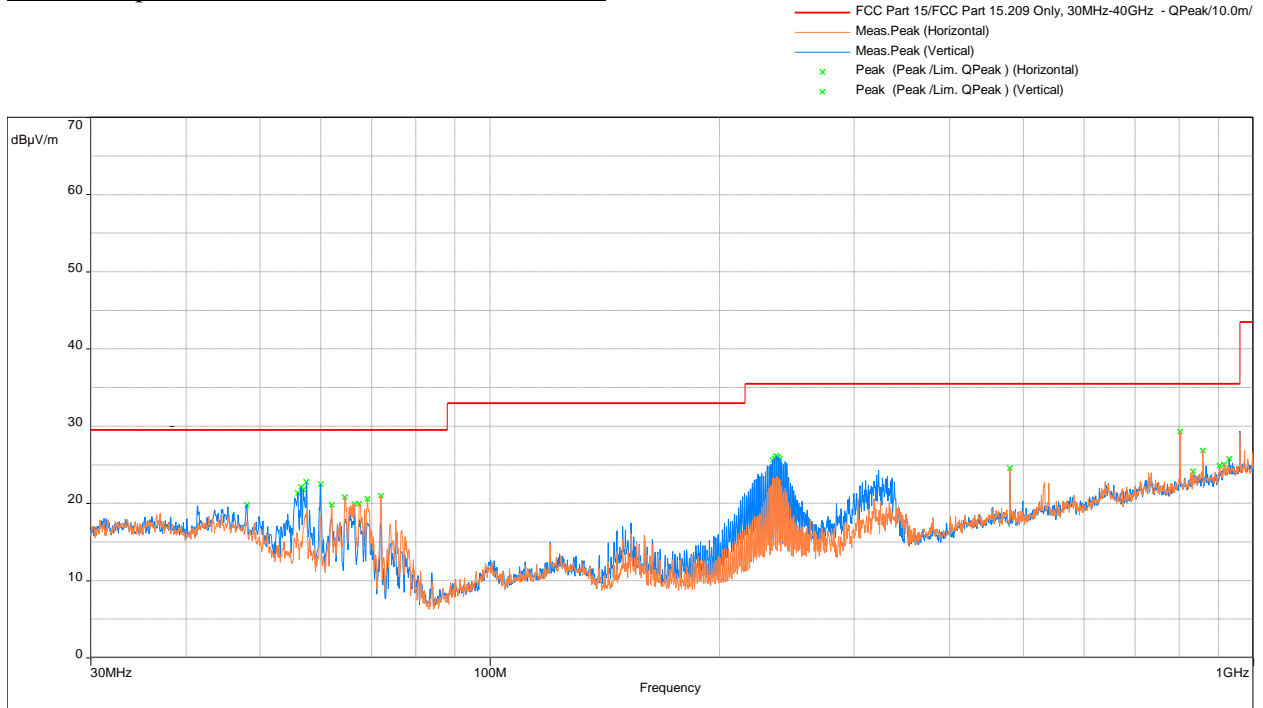

Model: ; Client: ; Comments: ; Test Date: 07/12/2018 10:58

Frequency	QP	Limit	Margin	Height	Angle	Polarization	Correction
MHz	dBµV/m	(dBµV/m)	(dB)	(m)	(°)		(dB)
801.830	29.25	35.5	-6.25	1.09	54	Horizontal	-3.49

**Radiated Spurious Emissions 1000 - 18000 MHz, Avg Scan vs Avg Limit**

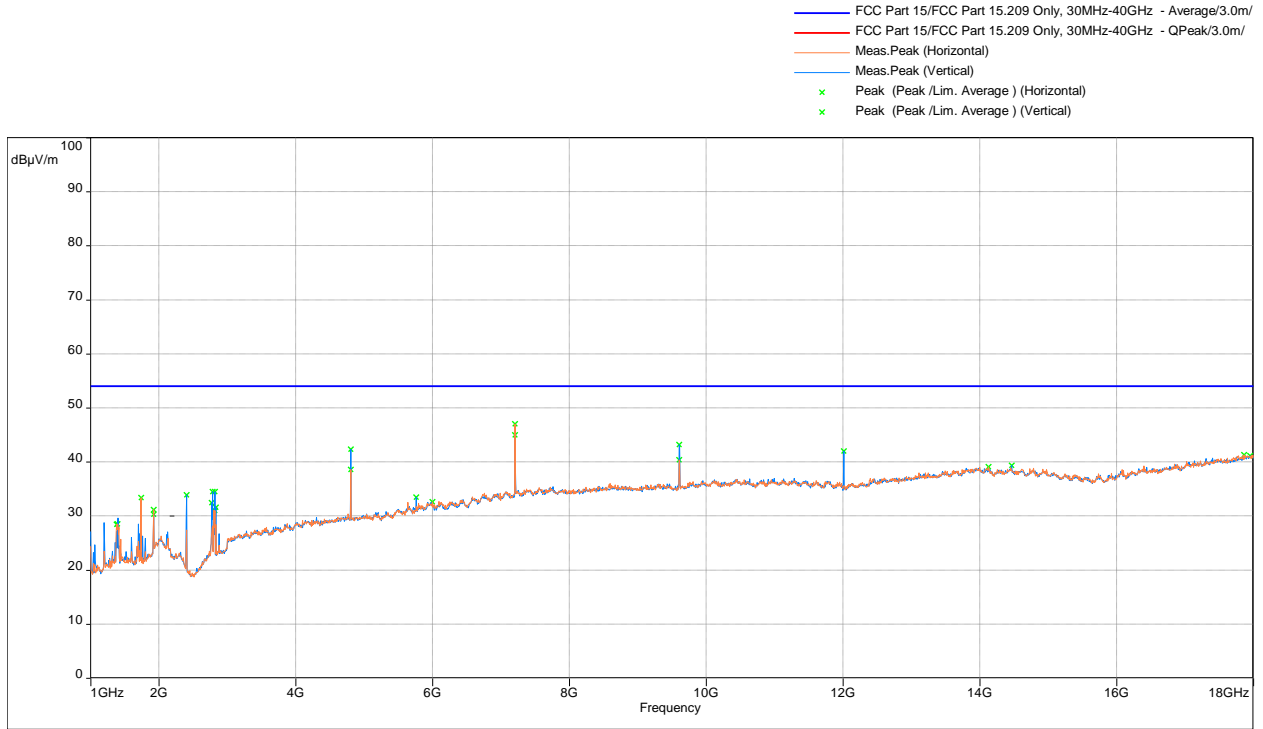

Model: ; Client: ; Comments: ; Test Date: 07/06/2018 10:07

Frequency MHz	Average dBµV/m	Limit (dBµV/m)	Margin (dB)	Height (m)	Angle (°)	Polarization	Correction (dB)
4804.0	42.34	54	-11.66	210	274	Vertical	4.92
7206.0	47.05	54	-6.95	200	157	Horizontal	11.95
9608.0	43.20	54	-10.80	188	175	Vertical	13.24
12010.0	41.95	54	-12.05	175	193	Vertical	13.78

Radiated Spurious Emissions 1000 - 18000 MHz, Peak Scan vs Peak Limit

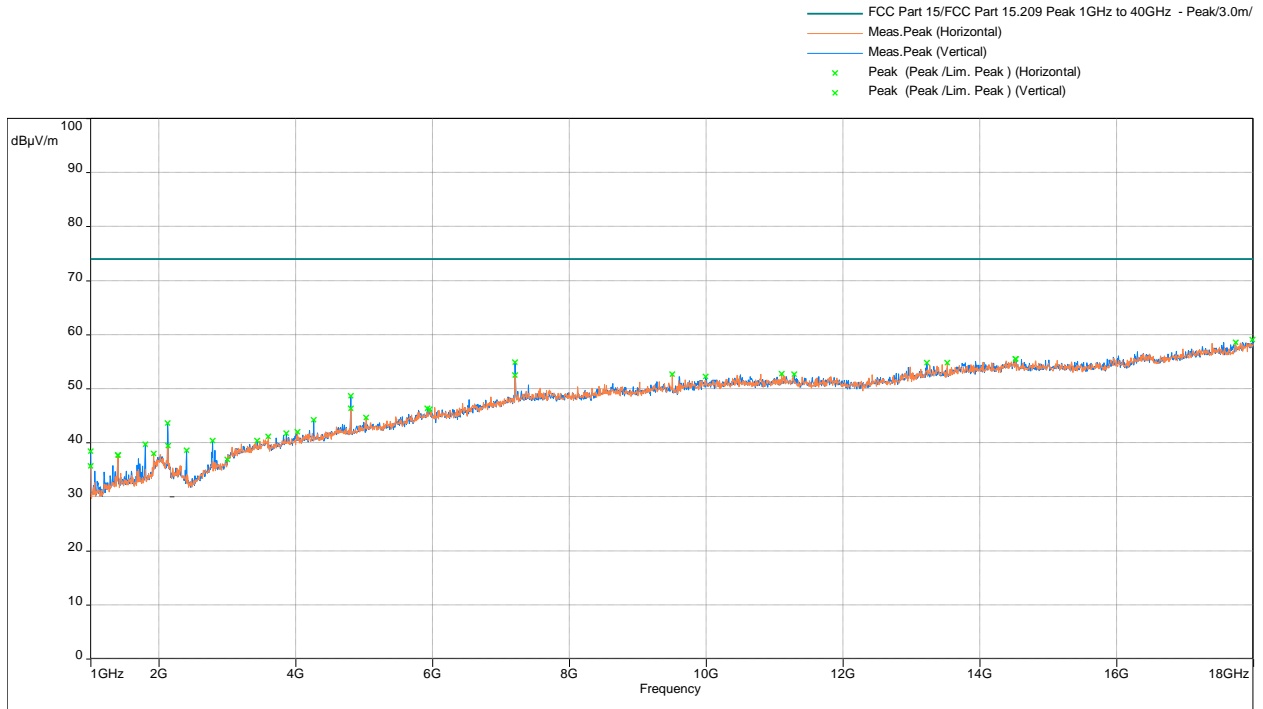

Note: Radiated emission measurements were performed up to 25GHz. No Emissions were identified when scanned from 18-25 GHz

Note: FS@3m = RA + AF + CF - Preamp

<b>Results</b>	<b>Complies</b>
----------------	-----------------

Test Results: 15.209 Radiated Spurious Emissions Mid Channel, Tx at 2439MHz

Radiated Spurious Emissions 30 MHz - 1000 MHz

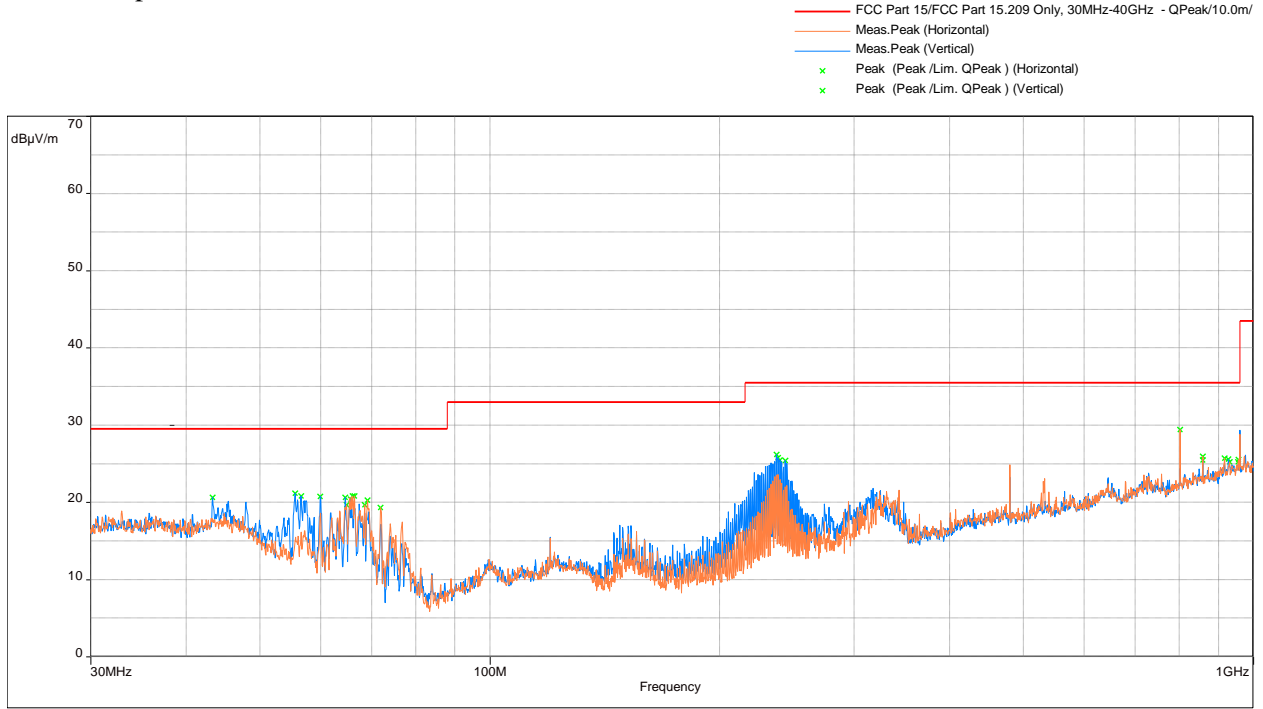

Frequency	QP	Limit	Margin	Height	Angle	Polarization	Correction
MHz	dBµV/m	(dBµV/m)	(dB)	(m)	(°)		(dB)
801.830	29.41	35.5	-6.09	1.02	206	Horizontal	-3.49



**Radiated Spurious Emissions 1000 - 18000 MHz, Avg Scan vs Avg Limit**

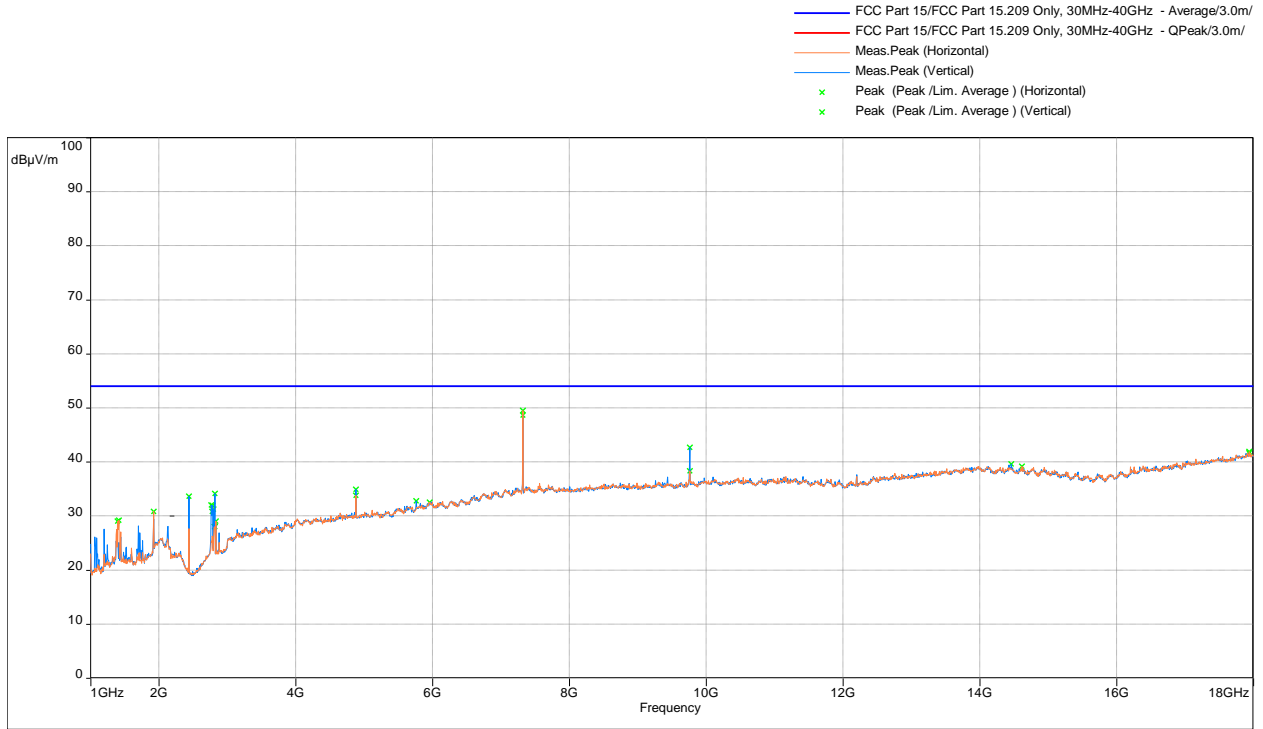

Model: ; Client: ; Comments: ; Test Date: 07/10/2018 06:34

Frequency	Average	Limit	Margin	Height	Angle	Polarization	Correction
MHz	dBµV/m	(dBµV/m)	(dB)	(m)	(°)		(dB)
4878.0	34.91	54	-19.09	1.99	43	Vertical	5.19
7317.0	49.46	54	-4.54	2.05	170	Horizontal	12.32
9756.0	42.7	54	-11.3	1.84	212	Vertical	13.34

Radiated Spurious Emissions 1000 - 18000 MHz, Peak Scan vs Peak Limit

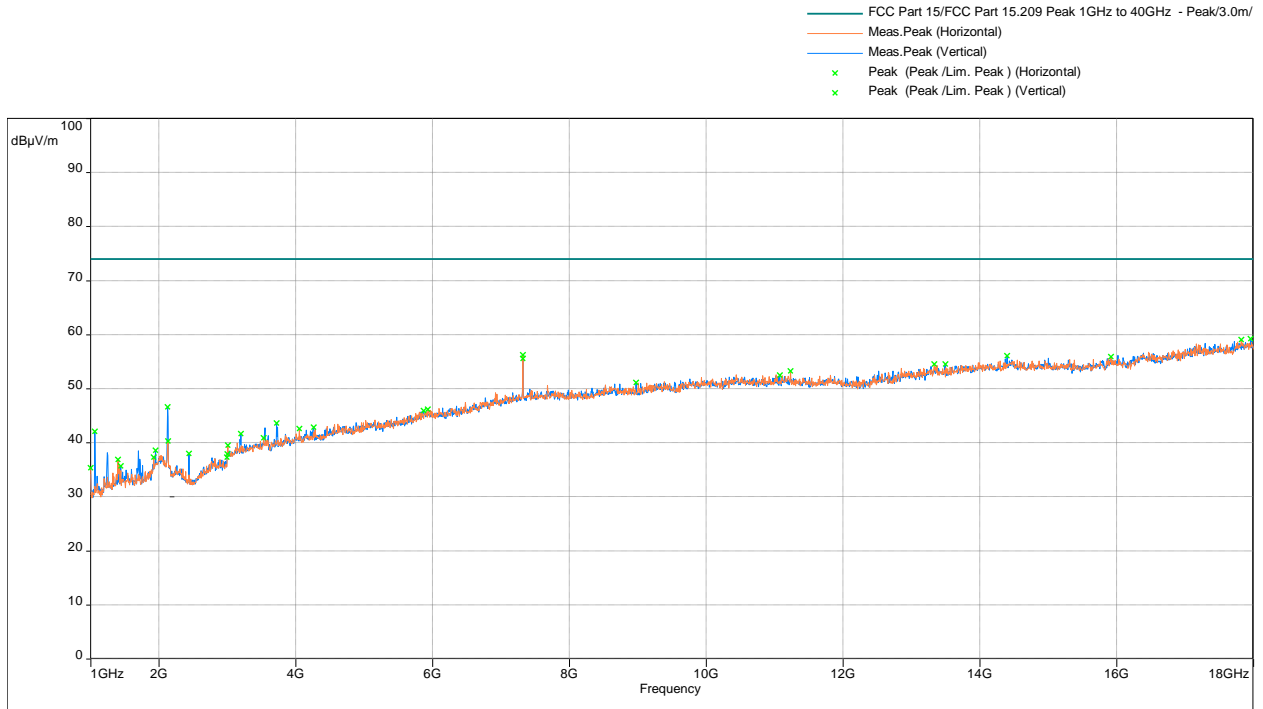

Note: Radiated emission measurements were performed up to 25GHz. No Emissions were identified when scanned from 18-25 GHz

Note: FS@3m = RA + AF + CF - Preamp

**Results** **Complies**

Test Results: 15.209 Radiated Spurious Emissions High Channel, Tx at 2479MHz

Radiated Spurious Emissions 30 MHz - 1000 MHz

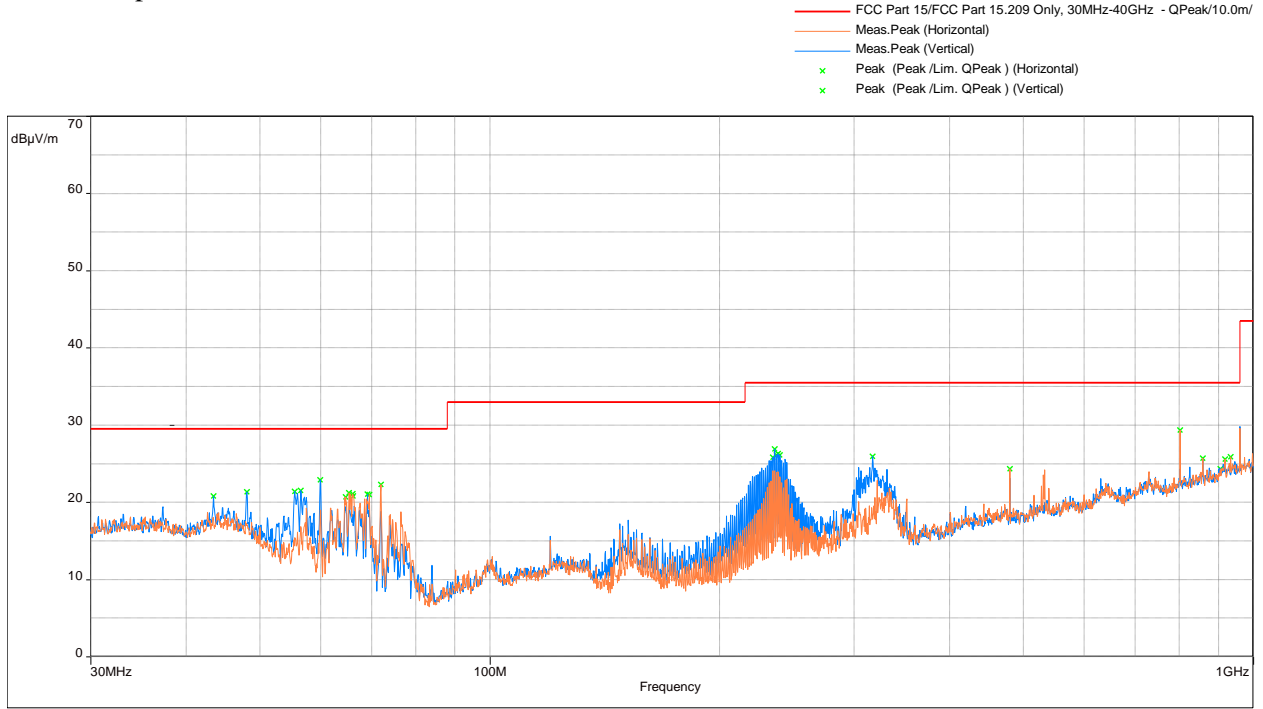

Frequency	QP	Limit	Margin	Height	Angle	Polarization	Correction
MHz	dBµV/m	(dBµV/m)	(dB)	(m)	(°)		(dB)
801.830	29.32	35.5	-6.18	1.00	87	Horizontal	-3.49

**Radiated Spurious Emissions 1000 - 18000 MHz, Avg Scan vs Avg Limit**

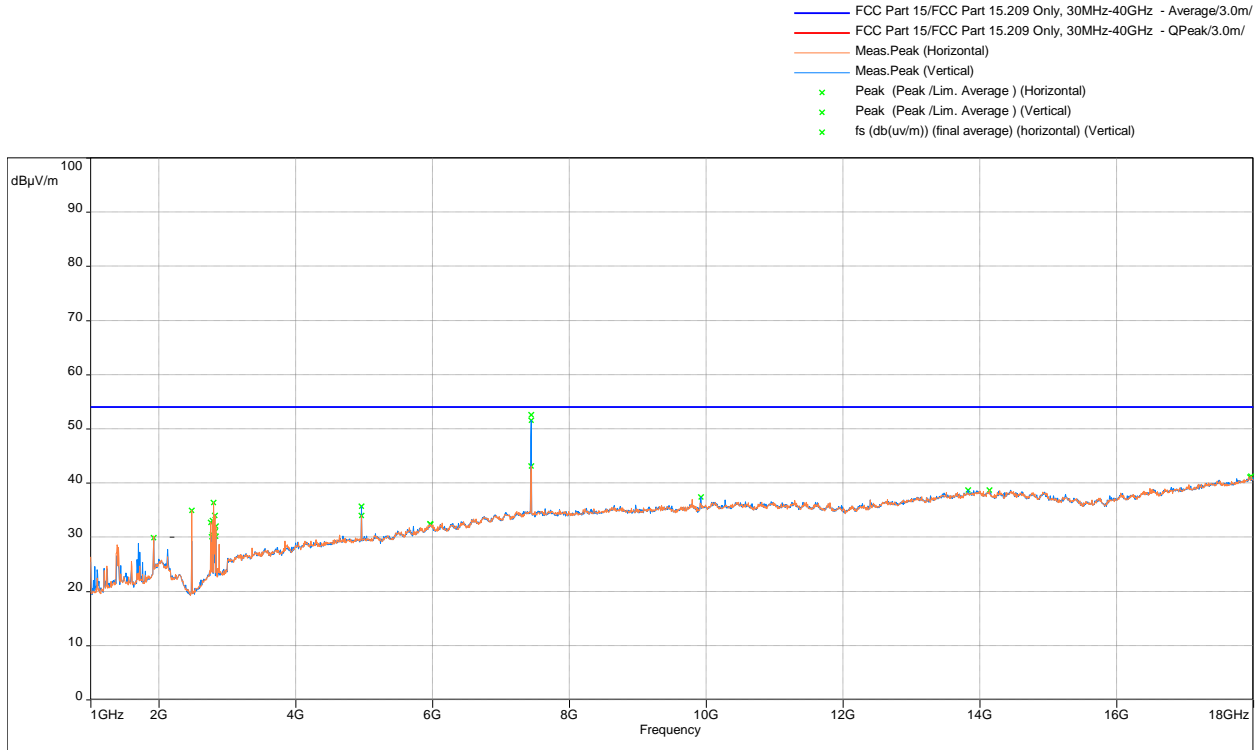

Model : Client : Comments : Test Date: 07/10/2018 07:52

Frequency	Average	Limit	Margin	Height	Angle	Polarization	Correction
MHz	dBµV/m	(dBµV/m)	(dB)	(m)	(°)		(dB)
4958.0	35.28	54	-18.72	2.05	157	Vertical	5.38
7437.0	52.55	54	-1.45	1.89	24	Vertical	12.36
9916.0	37.39	54	-16.61	1.99	222	Vertical	13.66

Radiated Spurious Emissions 1000 - 18000 MHz, Peak Scan vs Peak Limit

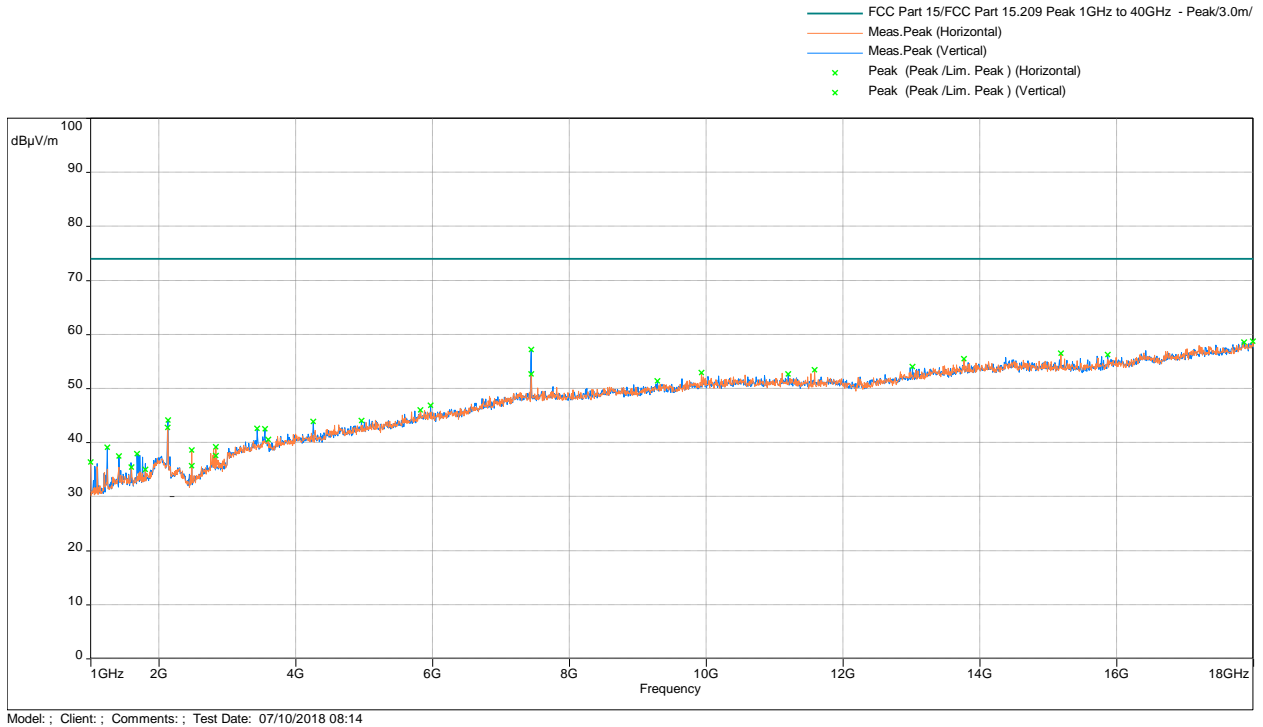

Note: Radiated emission measurements were performed up to 25GHz. No Emissions were identified when scanned from 18-25 GHz

Note: FS@3m = RA + AF + CF - Preamp

<b>Results</b>	<b>Complies</b>
----------------	-----------------

#### 4.5.7 Test Setup Configuration

**The following photographs show the testing configurations used.**



4.5.8 Test Setup Configuration (Continued)

**The following photographs show the testing configurations used.**

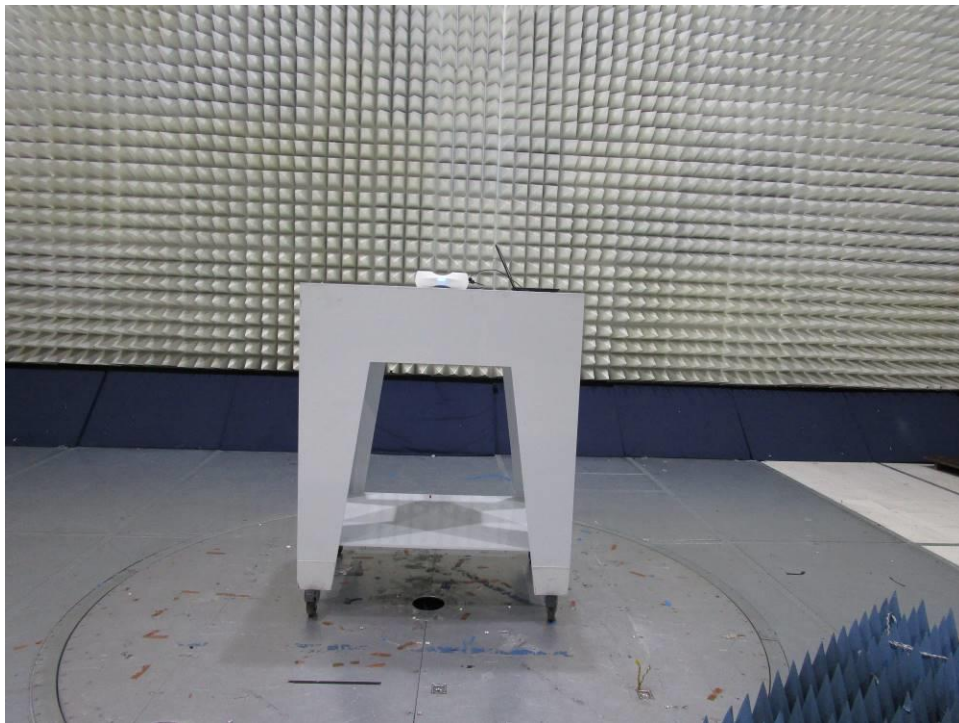

#### 4.5.7 Test Setup Configuration (Continued)

**The following photographs show the testing configurations used.**

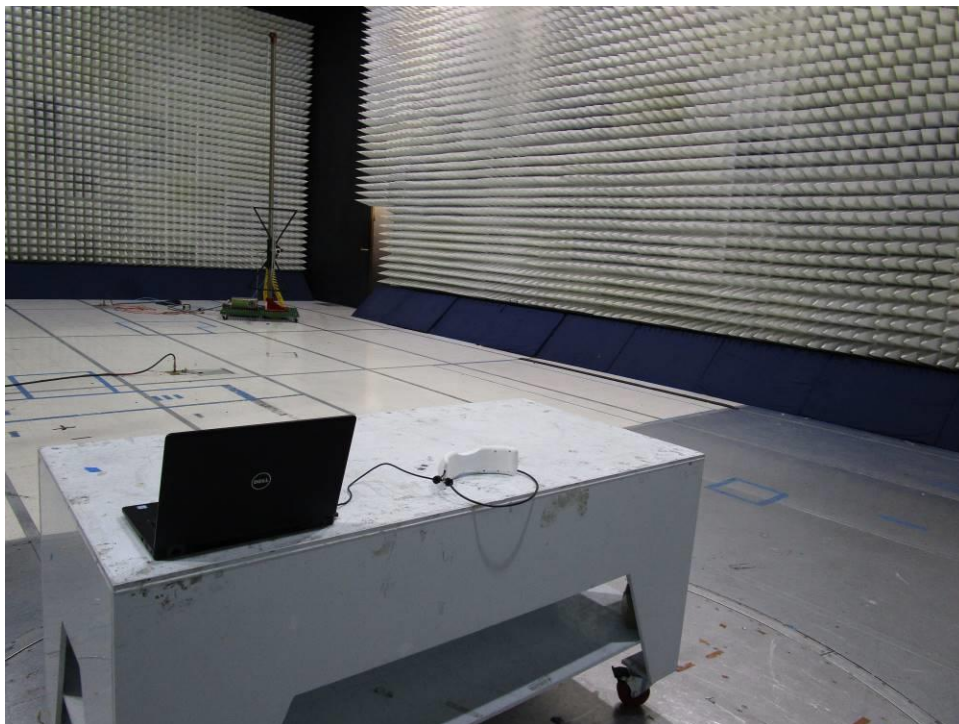



4.5.8 Co-located with WIFI (2.4 & 5 GHz)

**4.5.8.1 Out-of-Band Radiated Spurious Emissions while collocated with 2.4GHz WIFI& BLE**

Test Results: 15.209 Radiated Spurious Emissions Low Channel, Tx at 2402MHz

Radiated Spurious Emissions 30 MHz - 1000 MHz

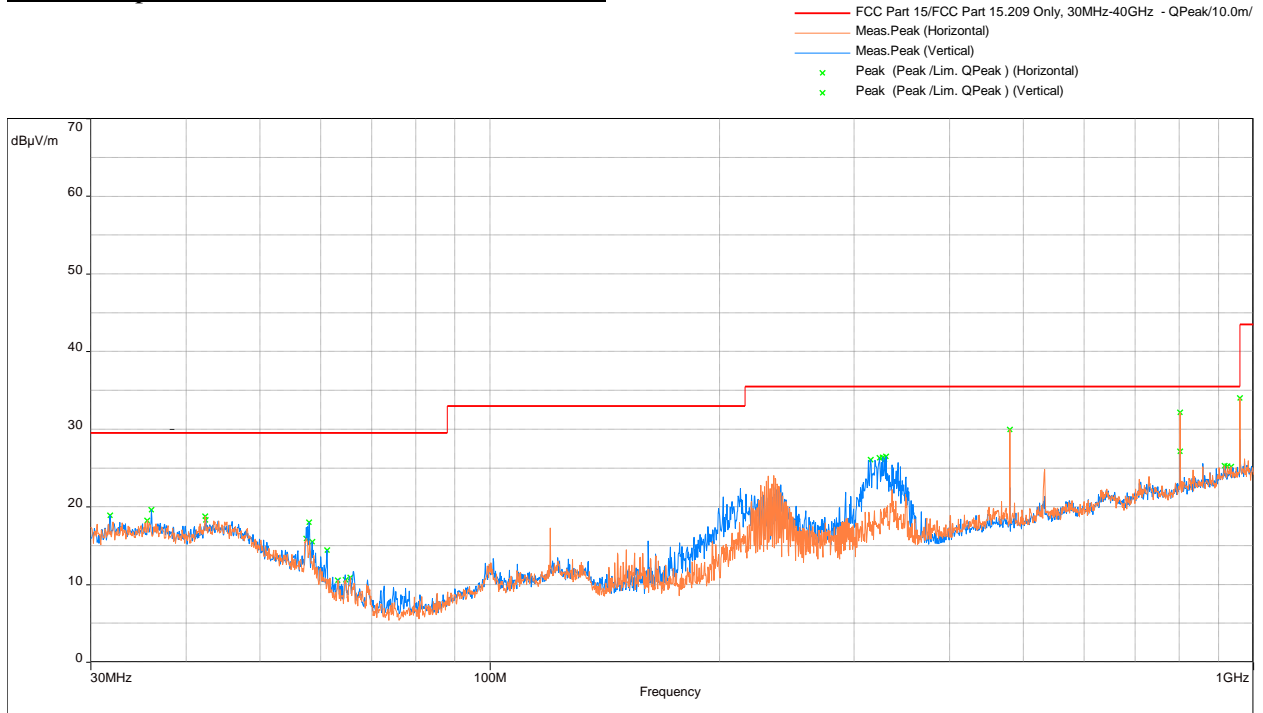

Frequency	QP	Limit	Margin	Height	Angle	Polarization	Correction
MHz	dBµV/m	(dBµV/m)	(dB)	(m)	(°)		(dB)
480.015	29.93	35.5	-5.57	2.00	211	Horizontal	-8.44
801.829	32.16	35.5	-3.34	1.02	230	Horizontal	-3.49
960.068	34.01	43.5	-9.49	1.27	250	Horizontal	-0.44

**Radiated Spurious Emissions 1000 - 18000 MHz, Avg Scan vs Avg Limit**

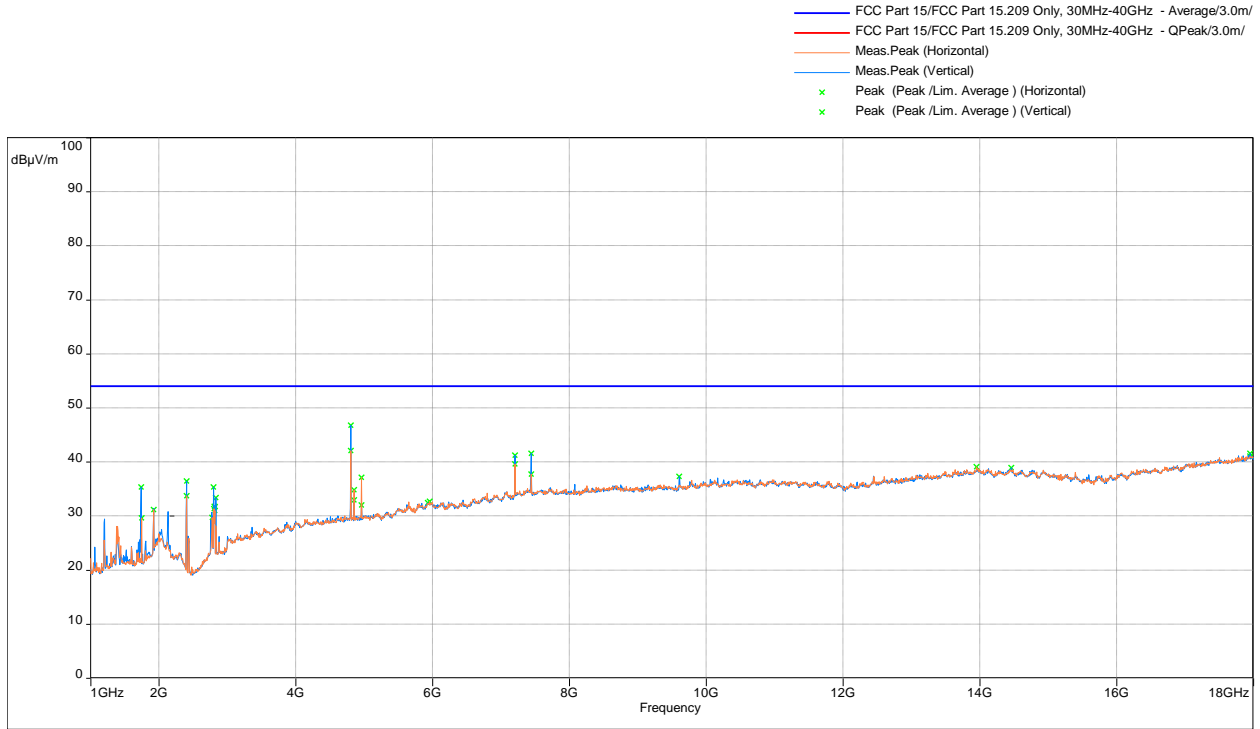

Model: ; Client: ; Comments: ; Test Date: 07/20/2018 06:47

Frequency MHz	Average dBµV/m	Limit (dBµV/m)	Margin (dB)	Height (m)	Angle (°)	Polarization	Correction (dB)
4804.0	46.79	54	-7.21	1.51	86	Vertical	4.92
7206.0	41.26	54	-12.74	1.88	355	Horizontal	11.95
7439.6	41.59	54	-12.41	2.10	145	Vertical	12.36
9608.0	37.29	54	-16.71	1.84	289	Vertical	13.24

Radiated Spurious Emissions 1000 - 18000 MHz, Peak Scan vs Peak Limit

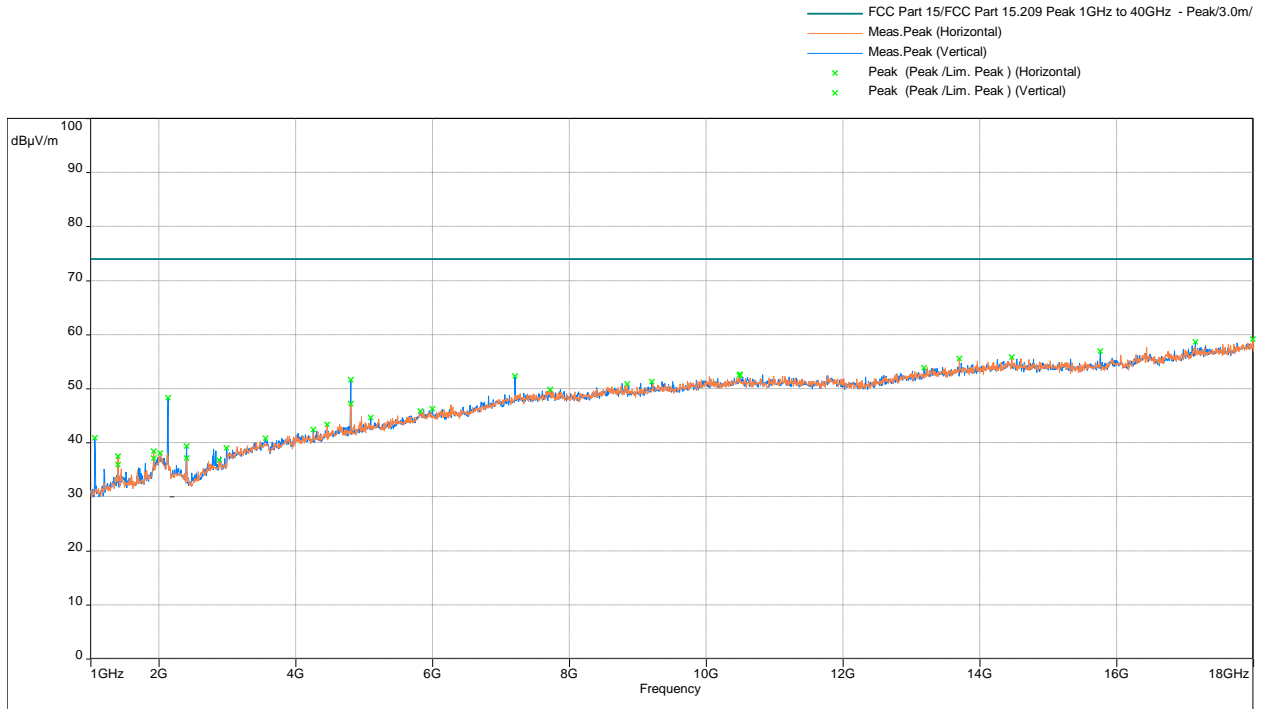

Model: ; Client: ; Comments: ; Test Date: 07/20/2018 06:54

Note: Radiated emission measurements were performed up to 25GHz. No Emissions were identified when scanned from 18-25 GHz

Note: FS@3m = RA + AF + CF - Preamp

<b>Results</b>	<b>Complies</b>
----------------	-----------------

Test Results: 15.209 Radiated Spurious Emissions Mid Channel, Tx at 2439MHz

Radiated Spurious Emissions 30 MHz - 1000 MHz

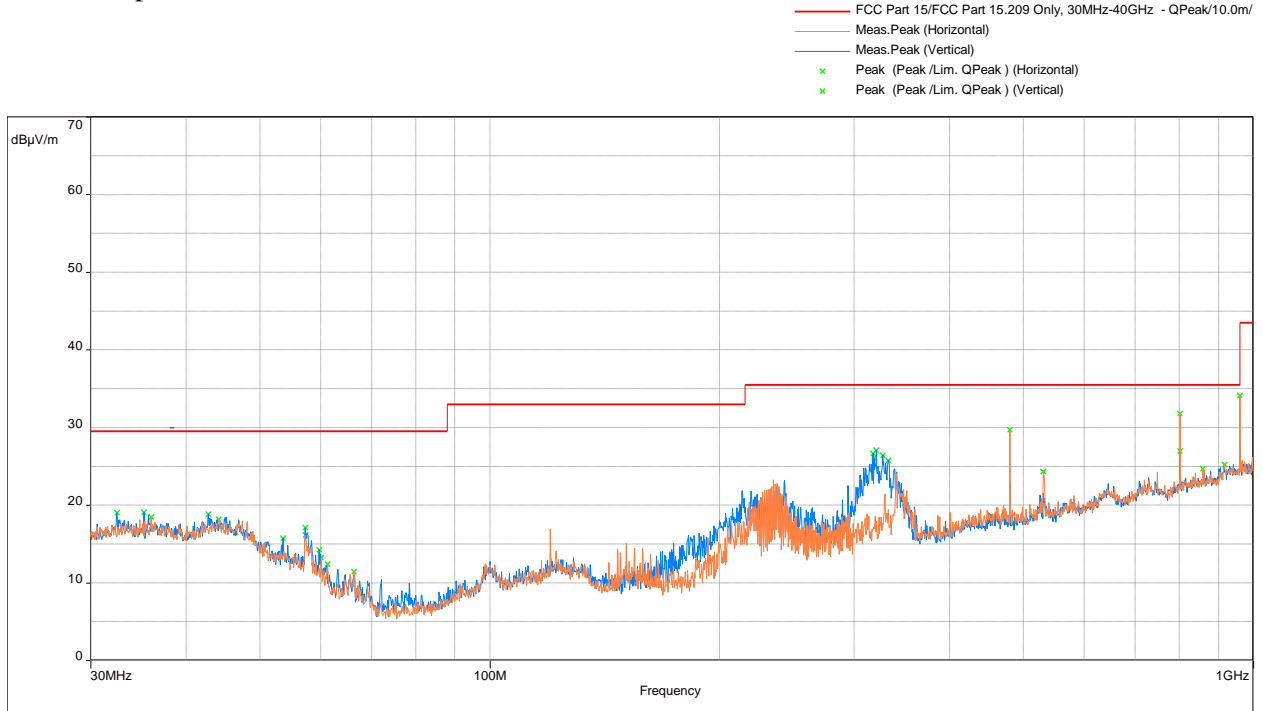

Frequency	QP	Limit	Margin	Height	Angle	Polarization	Correction
MHz	dBµV/m	(dBµV/m)	(dB)	(m)	(°)		(dB)
480.015	29.67	35.5	-5.83	1.98	213	Horizontal	-8.44
801.829	31.75	35.5	-3.75	1.00	170	Horizontal	-3.49
960.068	34.10	43.5	-9.40	1.14	203	Horizontal	-0.44

**Radiated Spurious Emissions 1000 - 18000 MHz, Avg Scan vs Avg Limit**

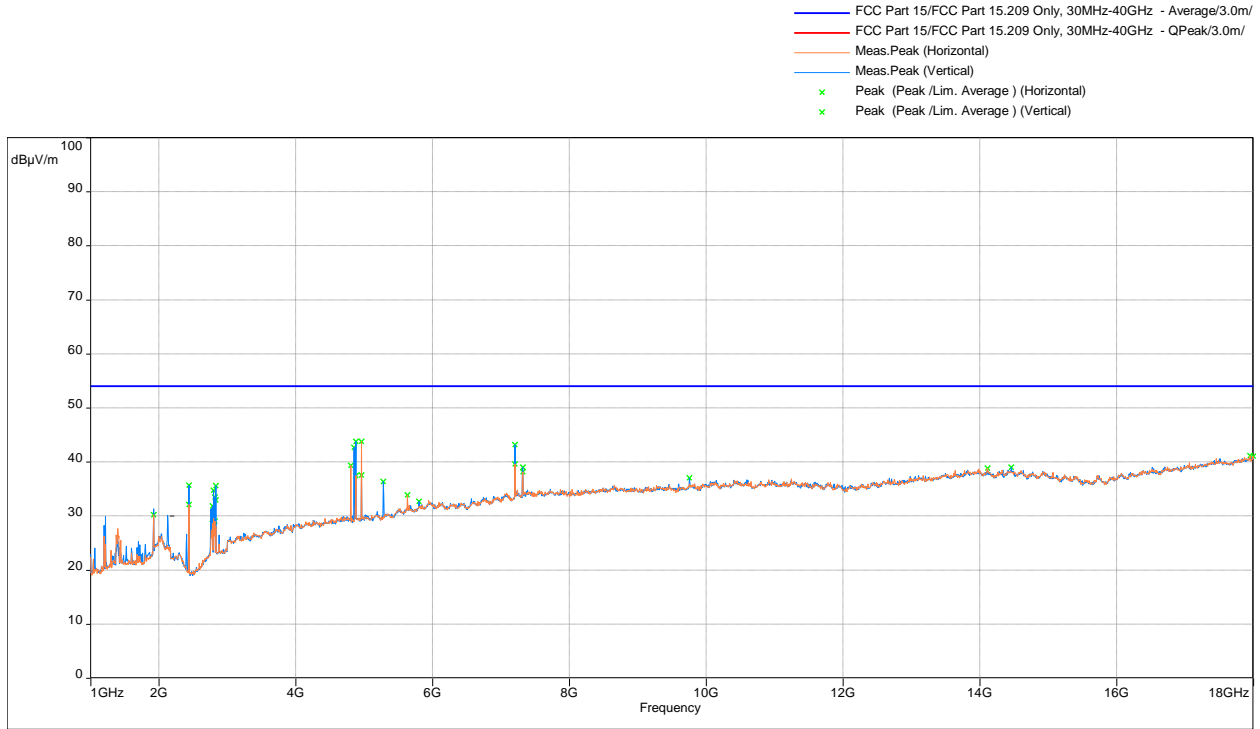

Model: ; Client: ; Comments: ; Test Date: 07/20/2018 07:01

Frequency MHz	Average dBµV/m	Limit (dBµV/m)	Margin (dB)	Height (m)	Angle (°)	Polarization	Correction (dB)
4852.2	42.69	54	-11.31	2.11	213	Vertical	5.06
4878.0	43.81	54	-10.19	1.99	99	Vertical	5.18
4959.3	43.80	54	-10.20	1.98	148	Horizontal	5.38
7206.7	43.15	54	-10.85	1.56	150	Vertical	11.95
7317.0	38.99	54	-15.01	1.45	258	Vertical	12.31
9756.0	37.01	54	-16.99	1.82	132	Vertical	13.33

Radiated Spurious Emissions 1000 - 18000 MHz, Peak Scan vs Peak Limit

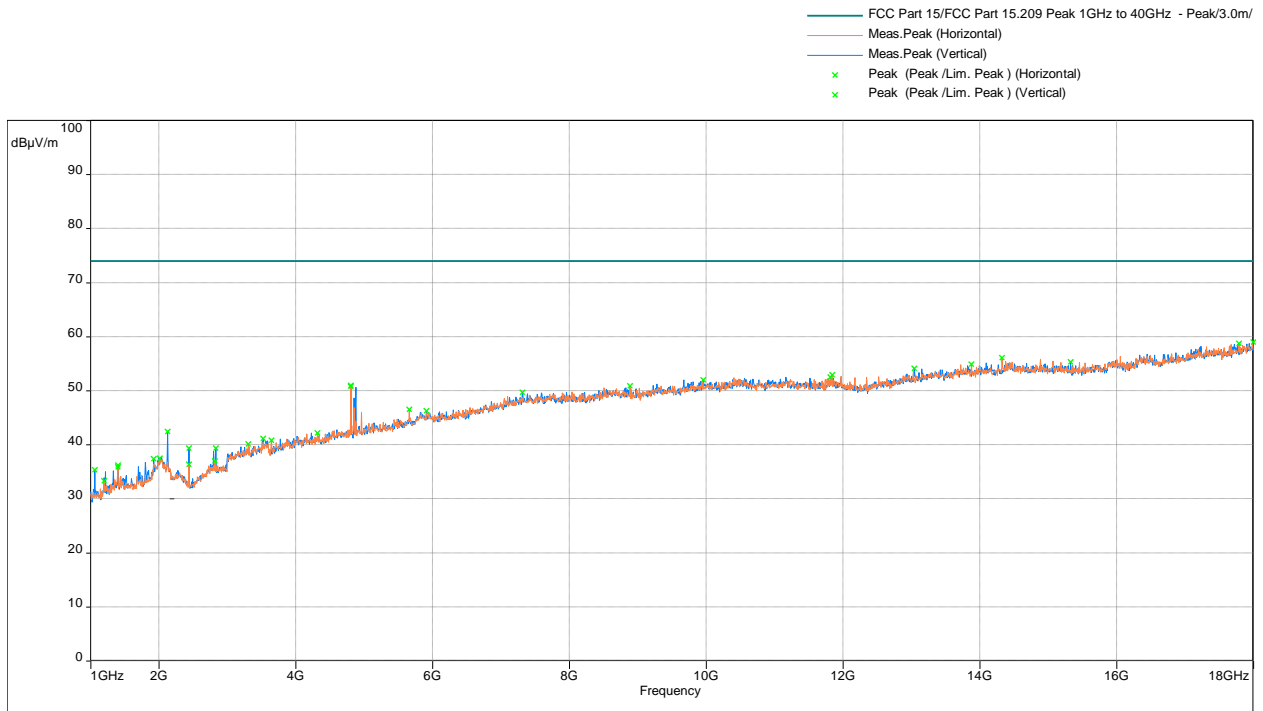

Note: Radiated emission measurements were performed up to 25GHz. No Emissions were identified when scanned from 18-25 GHz

Note: FS@3m = RA + AF + CF - Preamp

**Results** **Complies**

Test Results: 15.209 Radiated Spurious Emissions High Channel, Tx at 2479MHz

Radiated Spurious Emissions 30 MHz - 1000 MHz

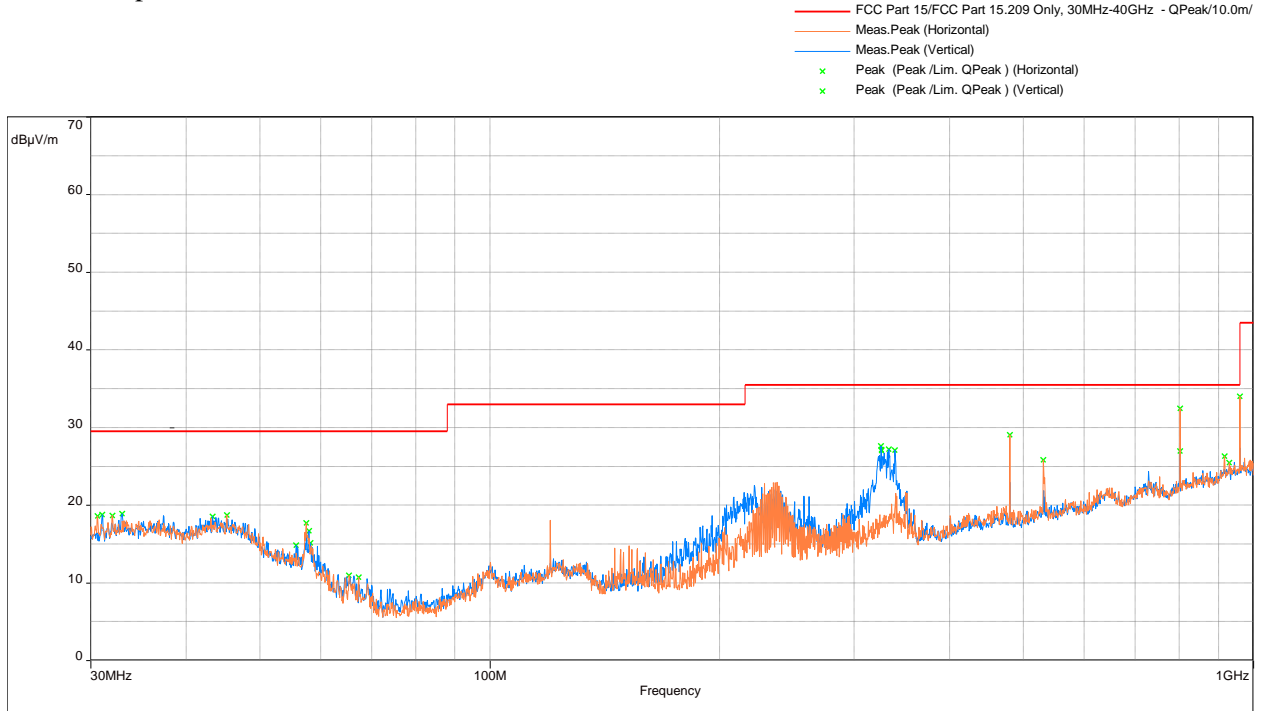

Frequency MHz	QP dBµV/m	Limit (dBµV/m)	Margin (dB)	Height (m)	Angle (°)	Polarization	Correction (dB)
480.015	29.05	35.5	-6.45	2.00	212	Horizontal	-8.44
801.829	32.46	35.5	-3.04	1.14	210	Horizontal	-3.49
960.068	33.97	43.5	-9.53	1.00	253	Horizontal	-0.44

Radiated Spurious Emissions 1000 - 18000 MHz, Avg Scan vs Avg Limit

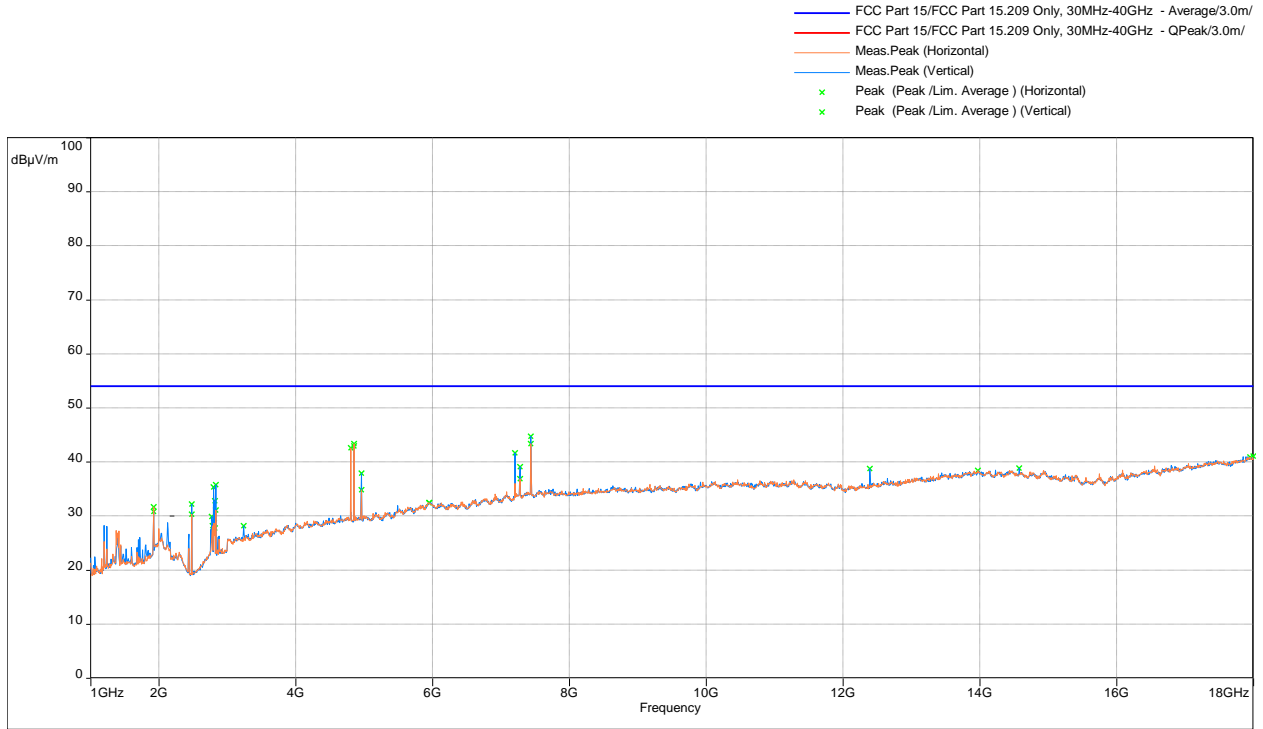

Frequency	Average	Limit	Margin	Height	Angle	Polarization	Correction
MHz	dBµV/m	(dBµV/m)	(dB)	(m)	(°)		(dB)
4804.6	42.61	54	-11.39	1.99	346	Horizontal	4.92
4852.2	43.39	54	-10.61	1.99	0	Horizontal	5.06
4957.6	37.89	54	-16.11	1.51	87.	Vertical	5.38
7205.0	41.62	54	-12.38	1.51	19	Vertical	11.94
7276.4	39.10	54	-14.9	1.99	100	Vertical	12.17
7437.0	44.7	54	-9.3	1.51	233	Vertical	12.36
12395	38.76	54	-15.24	1.99	191	Vertical	13.54



Radiated Spurious Emissions 1000 - 18000 MHz, Peak Scan vs Peak Limit

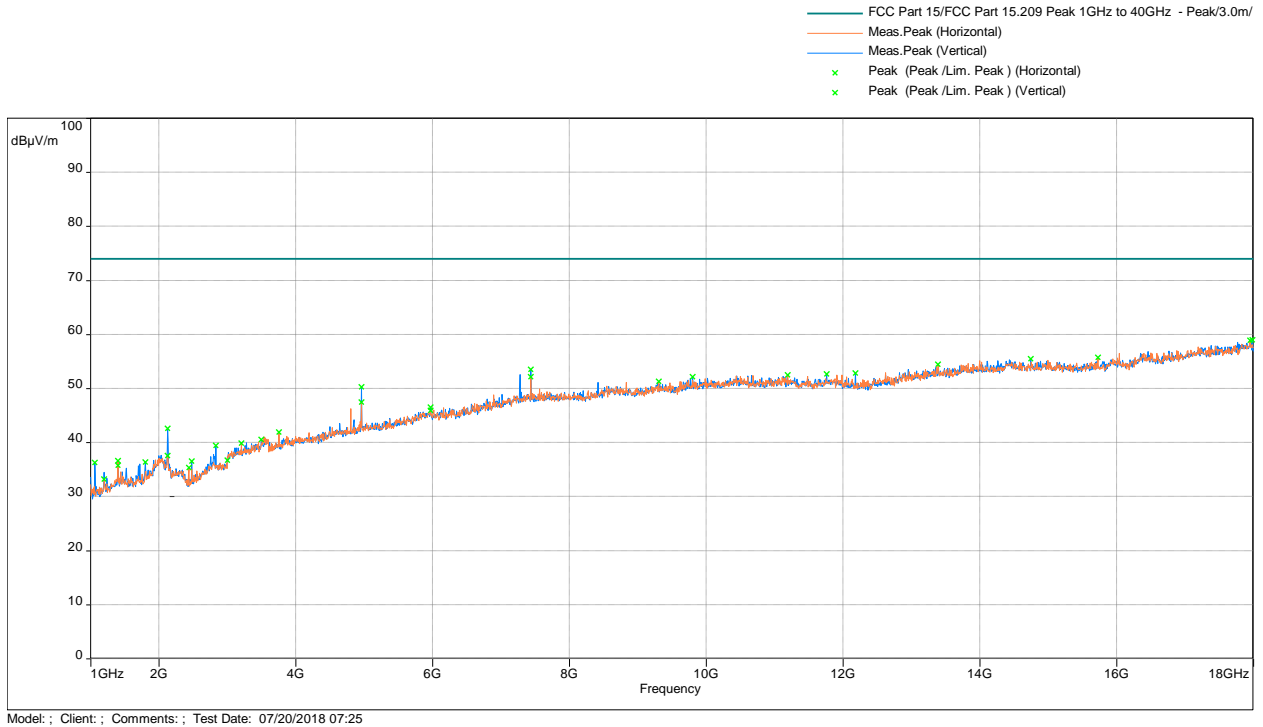

Note: Radiated emission measurements were performed up to 25GHz. No Emissions were identified when scanned from 18-25 GHz

Note: FS@3m = RA + AF + CF - Preamp

<b>Results</b>	<b>Complies</b>
----------------	-----------------

4.5.8 Co-located with WIFI (2.4 & 5 GHz) Continued

**4.5.8.2 Out-of-Band Radiated Spurious Emissions while collocated with 5 GHz WIFI & BLE**

Test Results: 15.209 Radiated Spurious Emissions Low Channel, Tx at 2402MHz

Radiated Spurious Emissions 30 MHz - 1000 MHz

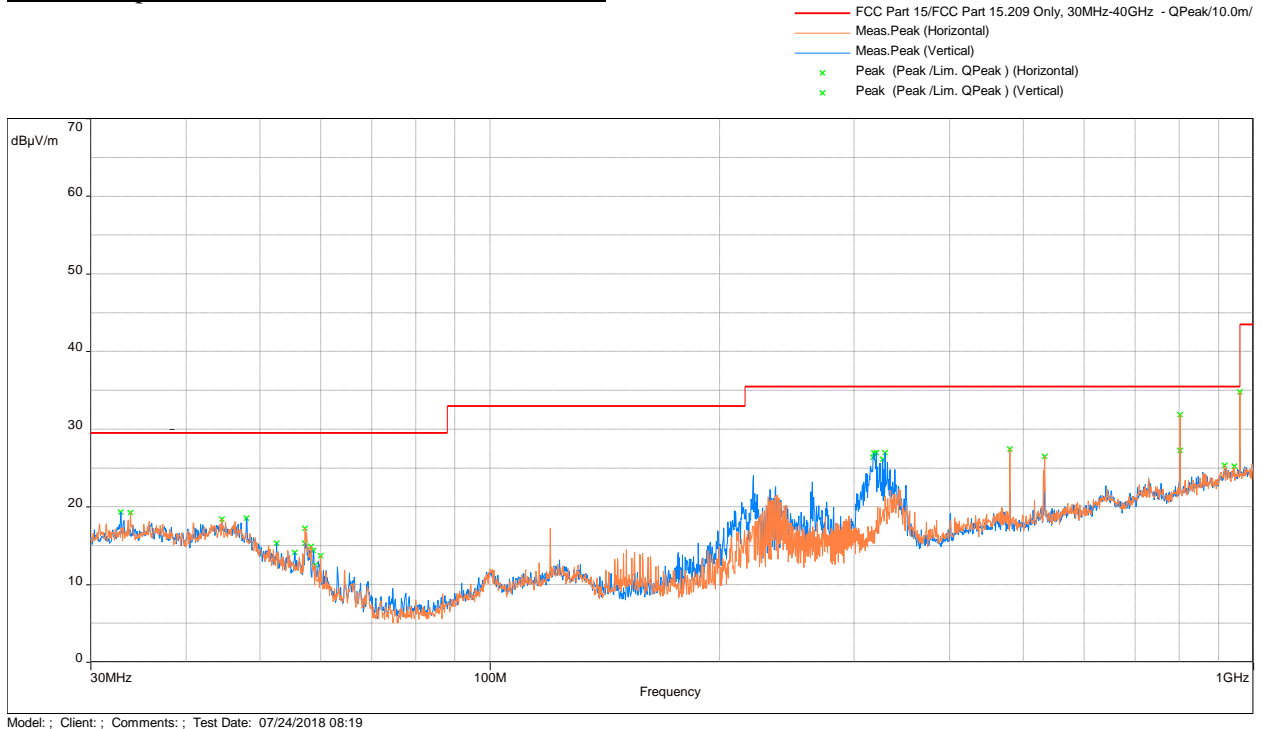

Frequency	QP	Limit	Margin	Height	Angle	Polarization	Correction
MHz	dBµV/m	(dBµV/m)	(dB)	(m)	(°)		(dB)
329.277	26.95	35.5	-8.55	1.00	199	Vertical	-11.42
480.015	27.41	35.5	-8.09	214	211	Horizontal	-8.44
801.829	31.84	35.5	-3.66	1.10	167	Horizontal	-3.49
960.068	34.75	43.5	-8.75	1.00	191	Horizontal	-0.44

**Radiated Spurious Emissions 1000 - 18000 MHz, Avg Scan vs Avg Limit**

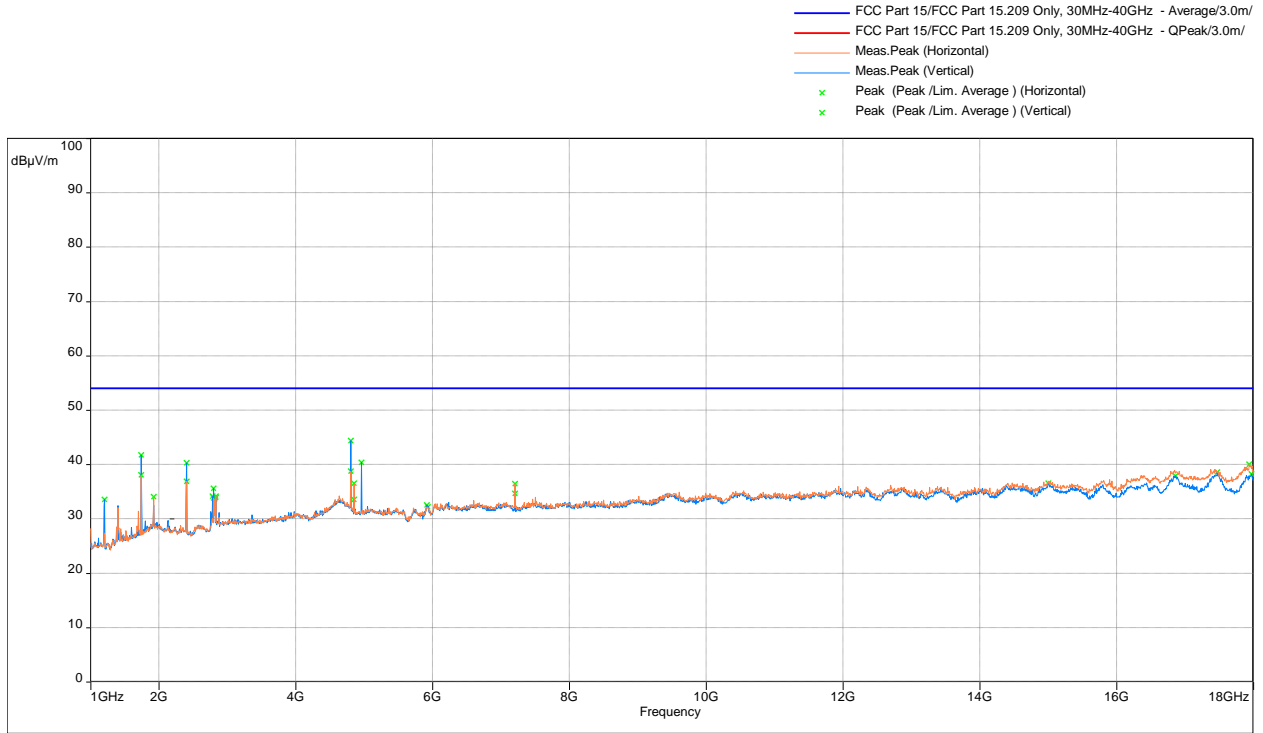

Model : ; Client : ; Comments : ; Test Date: 07/23/2018 07:13

Frequency MHz	Average dBµV/m	Limit (dBµV/m)	Margin (dB)	Height (m)	Angle (°)	Polarization	Correction (dB)
1739.5	38.03	54	-15.97	180	138	Horizontal	-16.24
4802.9	44.40	54	-9.60	1.50	203	Vertical	-7.74
4959.3	40.33	54	-13.67	1.82	244	Vertical	-8.49
7205.0	36.44	54	-17.56	1.91	299	Horizontal	-5.07

Radiated Spurious Emissions 1000 - 18000 MHz, Peak Scan vs Peak Limit

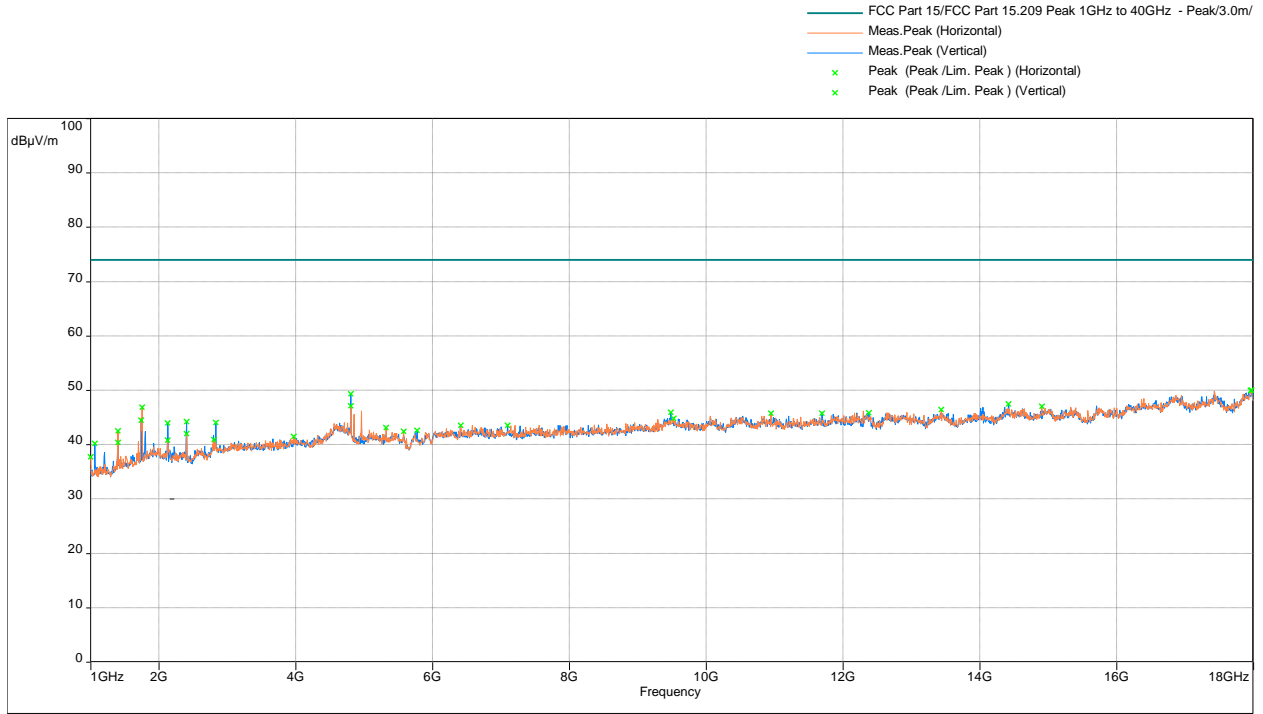

Note: Radiated emission measurements were performed up to 25GHz. No Emissions were identified when scanned from 18-25 GHz

Note: FS@3m = RA + AF + CF - Preamp

<b>Results</b>	<b>Complies</b>
----------------	-----------------

Test Results: 15.209 Radiated Spurious Emissions Mid Channel, Tx at 2439MHz

Radiated Spurious Emissions 30 MHz - 1000 MHz

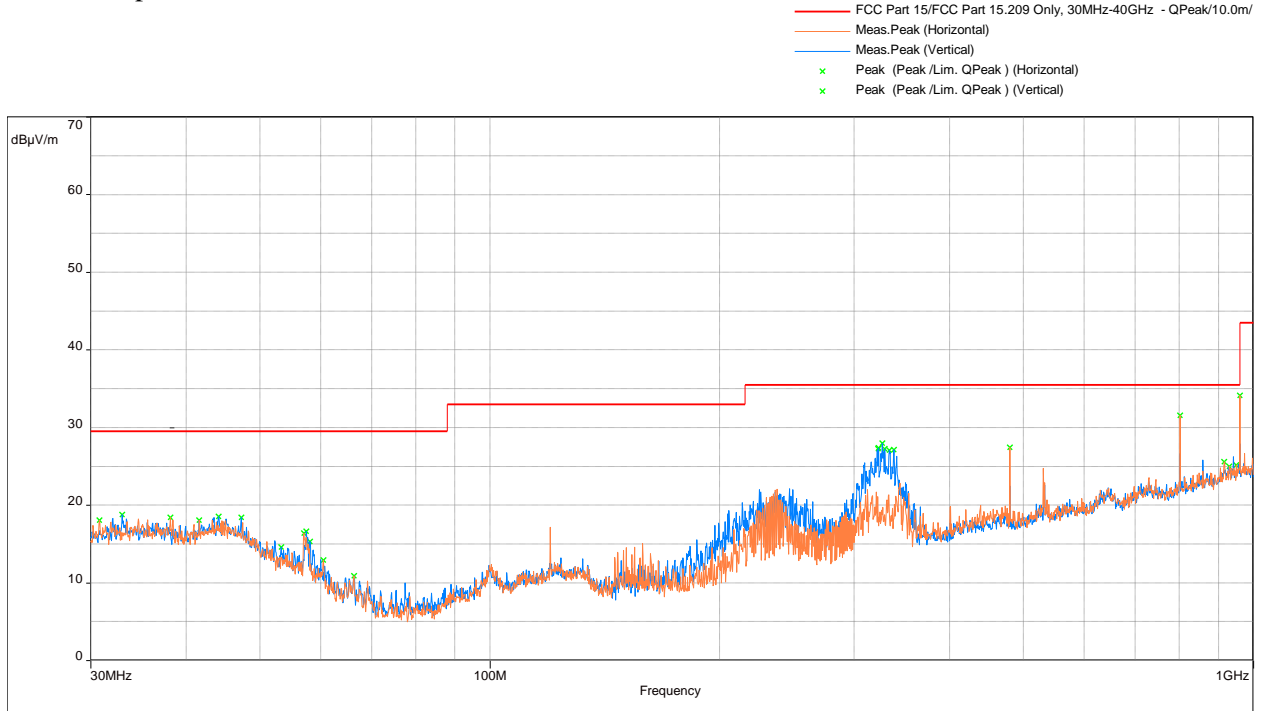

Frequency MHz	QP dBµV/m	Limit (dBµV/m)	Margin (dB)	Height (m)	Angle (°)	Polarization	Correction (dB)
326.755	27.98	35.5	-7.52	1.00	197	Vertical	-11.43
480.015	27.40	35.5	-8.10	1.75	201	Horizontal	-8.44
801.829	31.53	35.5	-3.97	1.23	339	Horizontal	-3.49
960.068	34.13	43.5	-9.37	1.11	192	Horizontal	-0.44

**Radiated Spurious Emissions 1000 - 18000 MHz, Avg Scan vs Avg Limit**

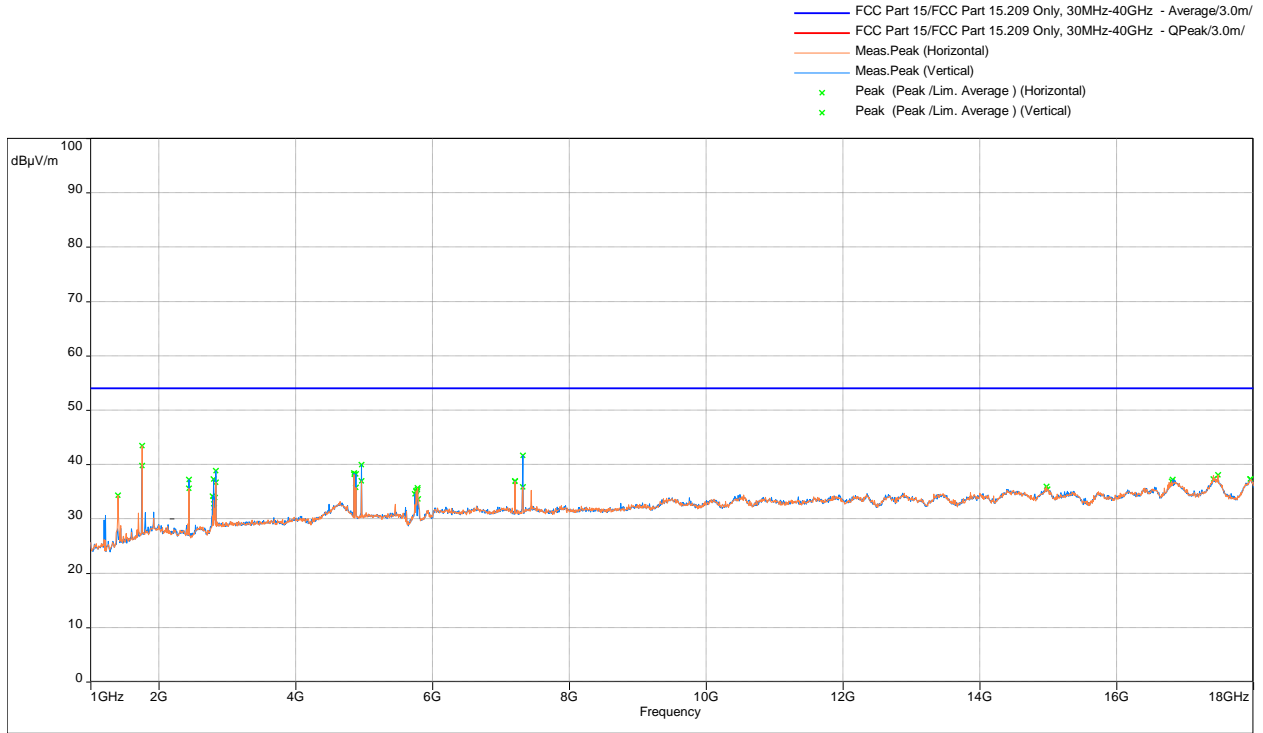

Model : Client : Comments : Test Date: 07/23/2018 08:04

Frequency MHz	Average dBµV/m	Limit (dBµV/m)	Margin (dB)	Height (m)	Angle (°)	Polarization	Correction (dB)
1753.1	43.47	54	-10.53	1.98	354	Horizontal	-16.18
2800.3	37.25	54	-16.75	1.62	119	Vertical	-13.27
4852.2	38.37	54	-15.63	1.45	78	Vertical	-8.22
4877.7	38.24	54	-15.76	1.63	218	Vertical	-8.33
4959.3	39.94	54	-14.06	1.55	51	Vertical	-8.49
7205.0	36.98	54	-17.02	1.73	29	Vertical	-5.07
7317.2	41.68	54	-12.32	1.69	57	Vertical	-5.05

Radiated Spurious Emissions 1000 - 18000 MHz, Peak Scan vs Peak Limit

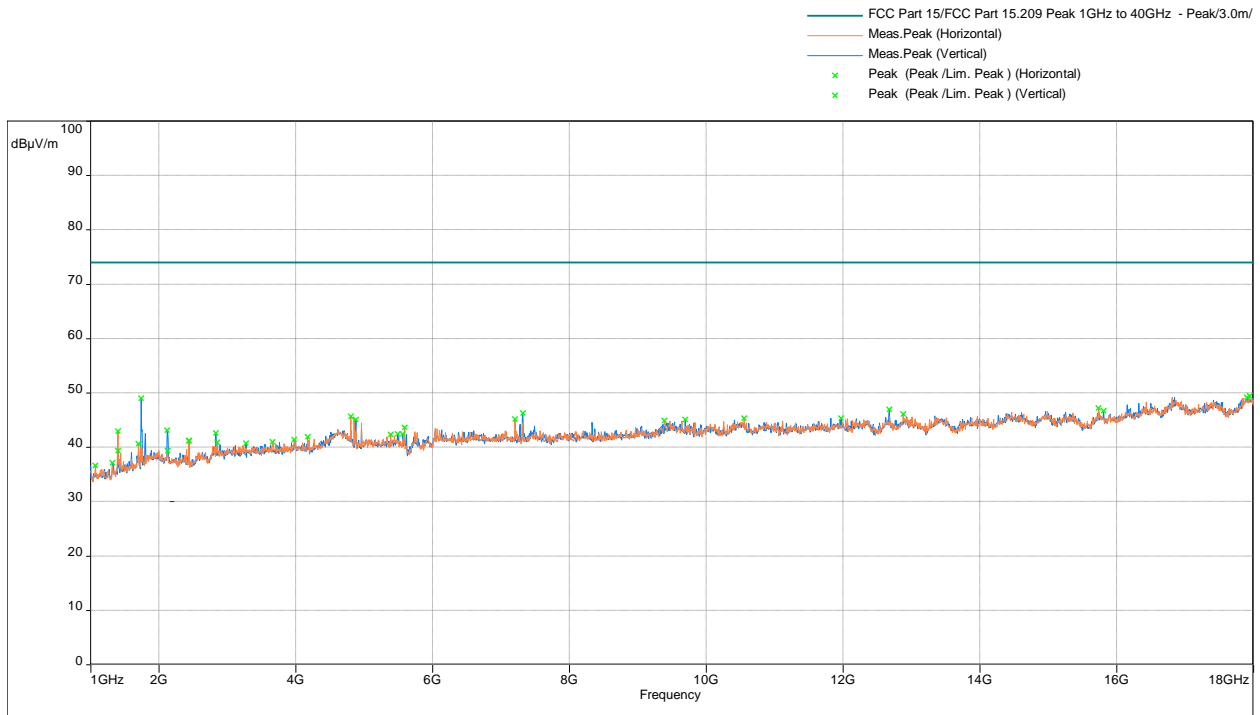

Note: Radiated emission measurements were performed up to 25GHz. No Emissions were identified when scanned from 18-25 GHz

Note: FS@3m = RA + AF + CF - Preamp

<b>Results</b>	<b>Complies</b>
----------------	-----------------

Test Results: 15.209 Radiated Spurious Emissions High Channel, Tx at 2479MHz

Radiated Spurious Emissions 30 MHz - 1000 MHz

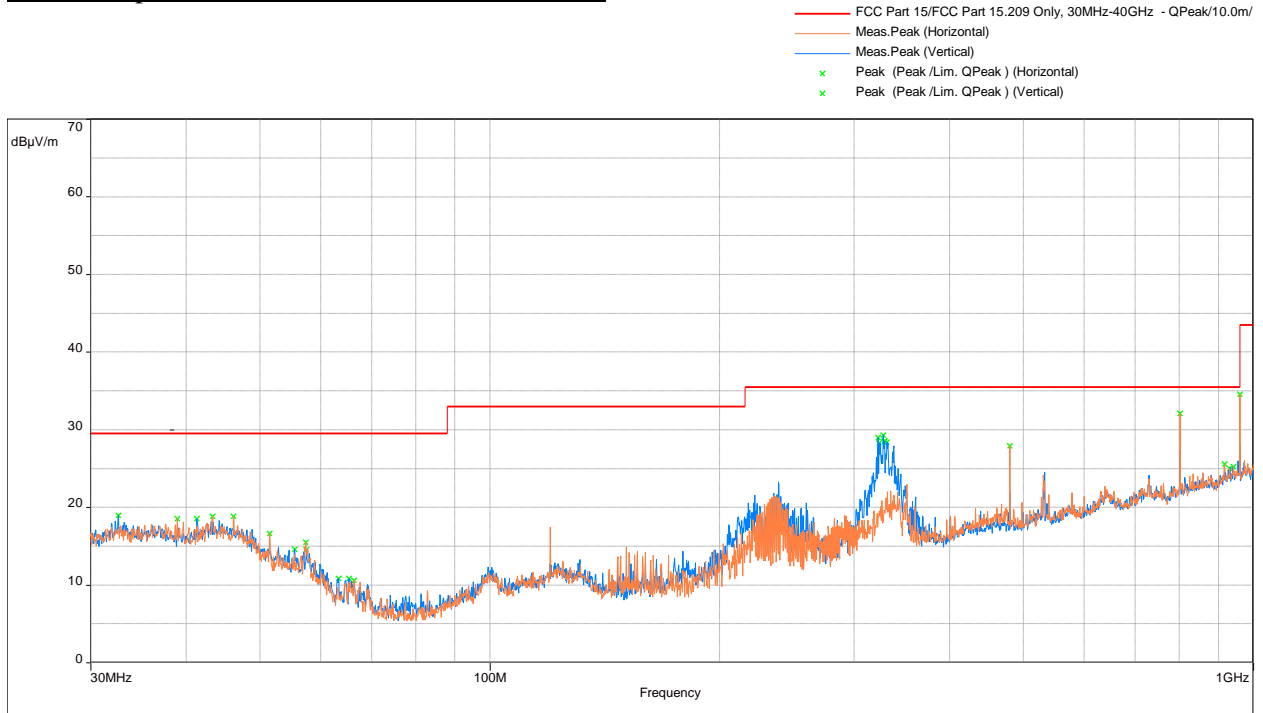

Frequency	QP	Limit	Margin	Height	Angle	Polarization	Correction
MHz	dBµV/m	(dBµV/m)	(dB)	(m)	(°)		(dB)
327.628	29.29	35.5	-6.21	1.25	200	Vertical	-11.43
480.015	27.87	35.5	-7.63	1.84	194	Horizontal	-8.44
801.829	32.08	35.5	-3.42	1.00	210	Horizontal	-3.49
960.068	34.52	43.5	-8.98	1.00	192	Horizontal	-0.44



Radiated Spurious Emissions 1000 - 18000 MHz, Avg Scan vs Avg Limit

- FCC Part 15/FCC Part 15.209 Only, 30MHz-40GHz - Average/3.0m/
- FCC Part 15/FCC Part 15.209 Only, 30MHz-40GHz - QPeak/3.0m/
- Meas.Peak (Horizontal)
- Meas.Peak (Vertical)
- x Peak (Peak /Lim. Average ) (Horizontal)
- x Peak (Peak /Lim. Average ) (Vertical)

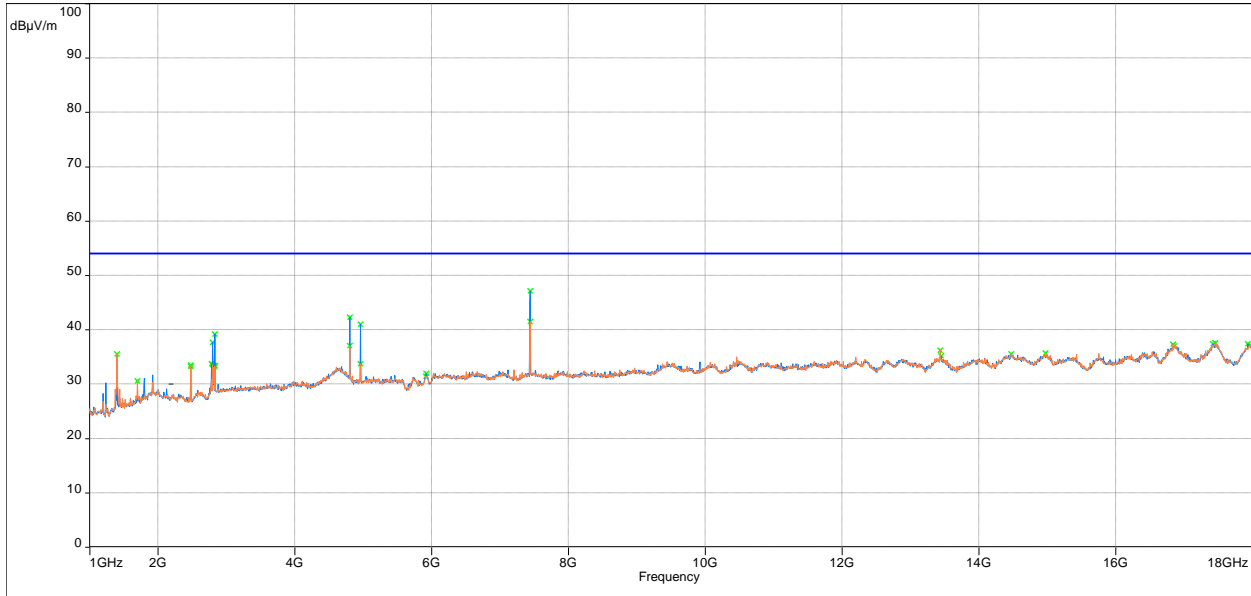

Model: ; Client: ; Comments: ; Test Date: 07/23/2018 08:23

Frequency	Average	Limit	Margin	Height	Angle	Polarization	Correction
MHz	dBµV/m	(dBµV/m)	(dB)	(m)	(°)		(dB)
1399.5	35.54	54	-18.46	2.01	126	Horizontal	-17.52
7439.6	41.51	54	-12.49	1.91	40	Horizontal	-4.79
2832.6	39.17	54	-14.83	1.48	207	Vertical	-13.25
4804.6	42.23	54	-11.77	1.96	114	Vertical	-7.76
4961	40.96	54	-13.04	1.55	145	Vertical	-8.49
7439.6	47.12	54	-6.88	1.52	59	Vertical	-4.79

Radiated Spurious Emissions 1000 - 18000 MHz, Peak Scan vs Peak Limit

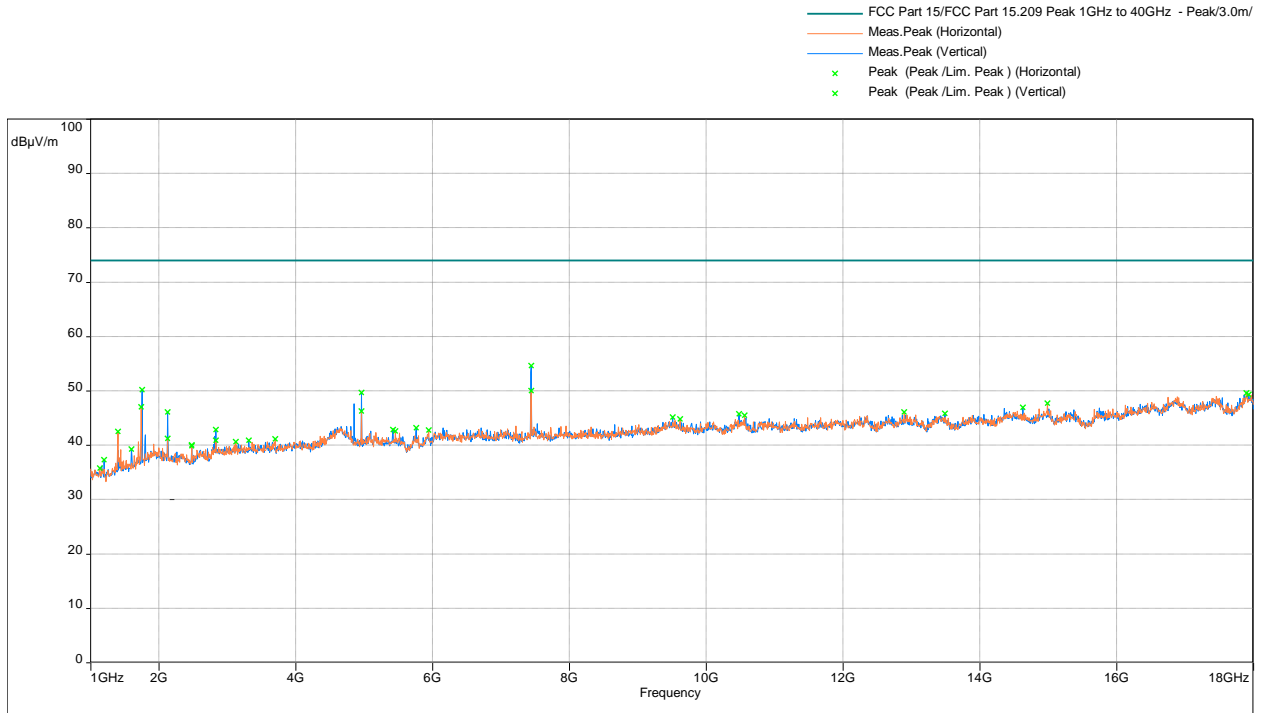

Note: Radiated emission measurements were performed up to 25GHz. No Emissions were identified when scanned from 18-25 GHz

Note: FS@3m = RA + AF + CF - Preamp

<b>Results</b>	<b>Complies</b>
----------------	-----------------

4.5.9 Test Setup Configuration (Co-located)

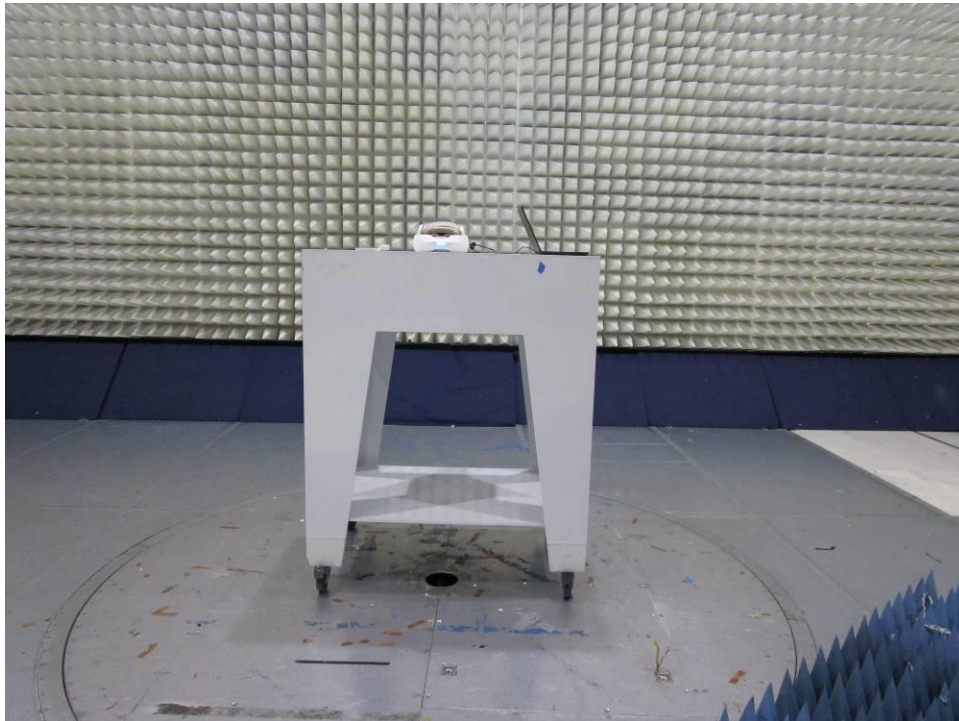
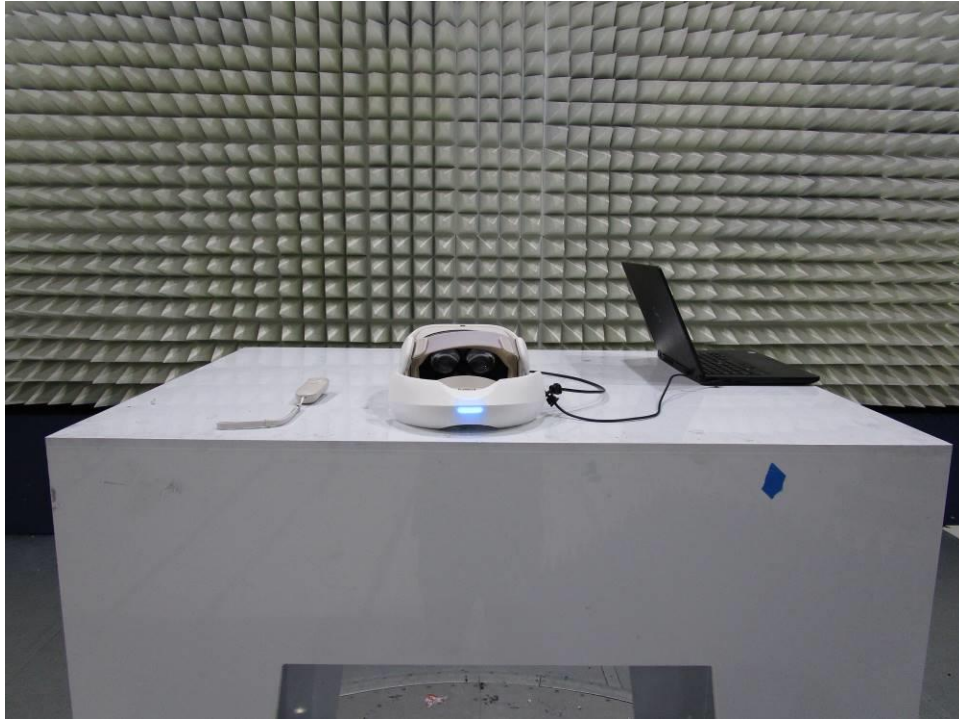

4.5.9 Test Setup Configuration (Co-located) Continued

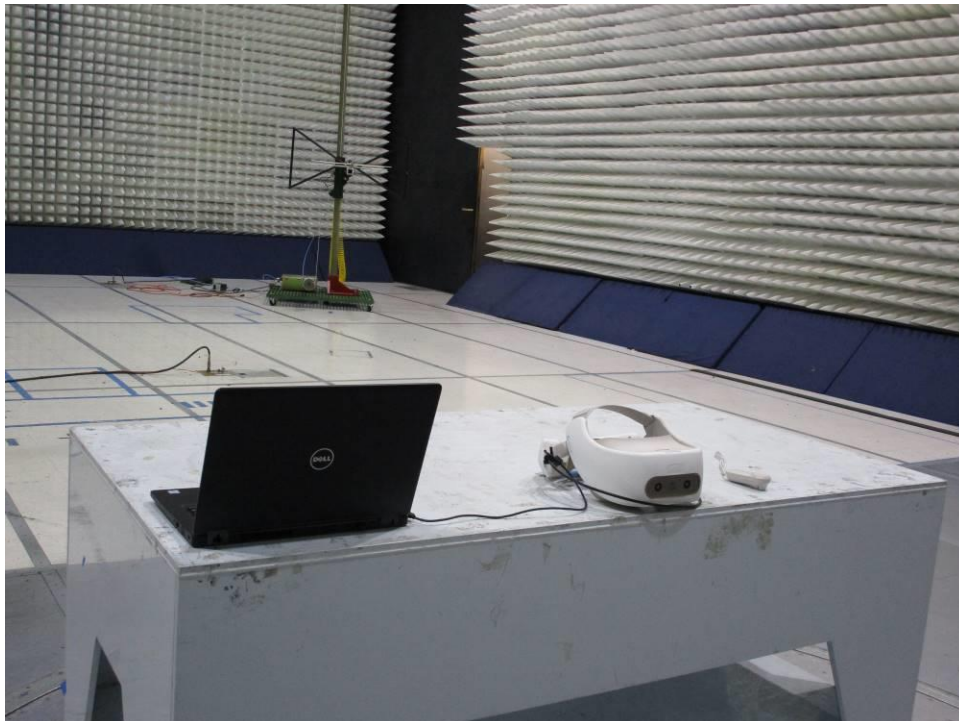

## 5.0 List of Test Equipment

Measurement equipment used for emission compliance testing utilized the equipment on the following list:

Equipment	Manufacturer	Model/Type	Asset #	Cal Int	Cal Due
Spectrum Analyzer	Rohde and Schwarz	FSU	ITS 00913	12	01/24/19
Pyramidal Horn Antenna	EMCO	3160-09	ITS 00571	#	#
Pre-Amplifier (18-40GHz)	Miteq	TTA1840-35-S-M	ITS 01393	12	01/19/19
Pre-Amplifier (1-18GHz)	Miteq	AMF-4D-001180-24-10P	ITS 00526	12	01/19/19
Active Horn Antenna	ETS-Lindgren	3117-PA	ITS 01325	12	01/25/19
EMI Receiver	Rohde and Schwarz	ESR7	ITS 01607	12	10/09/18
Horn Antenna	ETS-Lindgren	3115	ITS 00982	12	02/08/19
BI-Log Antenna	Schaffner	CBL 6112D	ITS 01058	12	08/11/18
Pre-Amplifier	Sonoma Instrument	310N	ITS 01493	12	10/20/18
RF Cable	TRU Corporation	TRU CORE 300	ITS 01462	12	08/19/18
RF Cable	TRU Corporation	TRU CORE 300	ITS 01465	12	08/19/18
RF Cable	TRU Corporation	TRU CORE 300	ITS 01470	12	08/19/18
Notch Filter	MICRO-TRONICS	BRM50702	ITS 01166	12	12/08/18
Notch Filter	MICRO-TRONICS	BRC50705	ITS 01169	12	03/14/19
RF Cable	Mega Phase	EMC1-K1K1-236	ITS 01538	12	06/13/18
10 dB Attenuator	Mini Circuits	BW-S10W5+	ITS 01582	12	08/31/18
RF Cable	TRU Corporation	TRU CORE 300	ITS 01330	12	11/29/18

# No Calibration required

Software used for emission compliance testing utilized the following:

Name	Manufacturer	Version	Template/Profile
Tile	Quantum Change	3.4.K.22	Conducted Spurious_30M-26GHz
BAT-EMC	Nexio	3.16.0.64	103541366_Penumbra.bpp
RS Commander	Rohde Schwarz	1.6.4	Not Applicable (Screen grabber)

**6.0 Document History**

<b>Revision/ Job Number</b>	<b>Writer Initials</b>	<b>Reviewers Initials</b>	<b>Date</b>	<b>Change</b>
1.0 / G103541366	AS	KV	August 08, 2018	Original document