



Add value.
Inspire trust.

Report On

FCC and ISED Testing of the Octasic Base Station Radio (V850) in accordance with FCC CFR 47 Part 2, FCC CFR 47 Part 27C

COMMERCIAL-IN-CONFIDENCE

FCC: 2AQSOCBRSYS6800

PREPARED BY

Jose Martinez

APPROVED BY

Scott Drysdale

DATED

April 21, 2021

April 21th, 2021

Page 1 of 68

Report Issued:
4/26/2021

Report File #:
TR-7169008986A - Issue 1 - 003





CONTENTS

Section	Page No
1	REPORT INFORMATION 2
1.1	Report Details 3
1.2	Brief Summary of Results 4
1.3	Product Information 5
1.4	Declaration of Build Status 7
2	MAIN EUT 7
1.5	General Test Setup..... 9
1.6	Test Conditions..... 10
1.7	Deviation From The Standard 10
1.8	Modification Record..... 10
1.9	Additional Information 10
3	TEST DETAILS 11
2.1	Maximum Peak Output Power and Peak to Average Ratio - Conducted..... 12
2.2	Occupied Bandwidth..... 28
2.3	Band Edge 32
2.4	Transceiver Spurious Emissions – Conducted..... 48
2.5	Frequency Stability 55
2.6	Field streNgtH of spurious emission– Radiated 56
4	TEST EQUIPMENT USED 63
3.1	Test Equipment Used 64
3.2	Measurement Uncertainty 65
5	ACCREDITATION, DISCLAIMERS AND COPYRIGHT 66
4.1	Accreditation, Disclaimers and Copyright..... 67



SECTION 1

REPORT INFORMATION



1.1 REPORT DETAILS

Manufacturer	Octasic inc.
Manufacturer Description	CBRSYS6800
Address	2901 Rachel St. East, Suite 30. Montreal, QC, H1W 4A4
Product Name	Base Station Radio (V850)
Product Number	CBRSYS6800 (CBRRFE6600 & CBRSYS6200)
Serial Number(s)	CBRSYS6200: K-21572 CBRRFE6600: K-21570
Hardware Version(s)	CBRSYS6200 Rev1 CBRREF6600 Rev1
Software Version(s)	BRREF6600 03.00.00-B0004-DEV CBRSYS6800 03.03.00-D1115\HFPBU_RDT_EXE-02.01.01-B6
Test Specification/Issue/Date	FCC CFR 47 Part 2: 2016 FCC CFR 47 Part 27: 2016
Start of Test	March 12 th , 2021
Finish of Test	April 7 th , 2021
Name of Test Personnel(s)	Scott Drysdale and Jose Martinez
Related Document(s)	KDB 971168 D01 v02r02 KDB 662911 D01 v02r01
Test report revision history	Issue 1 – 000. Initial release. Issue 1 – 001. Section 1.3 was added. Issue 1 – 002. Section 2.6 was added.



1.2 BRIEF SUMMARY OF RESULTS

A brief summary of results for each configuration, in accordance with FCC CFR 47 Part 2 and FCC CFR 47 Part 27 is shown below.

Section	Test Description		Result	
	FCC CFR 47 Part 2	FCC CFR 47 Part 27		
2.1	2.1046	27.50	Maximum Peak Output Power and Peak to Average Ratio - Conducted	Pass
2.2	2.1049	27.53	Occupied Bandwidth	Pass
2.3	2.1051	27.53 (h)	Band Edge	Pass
2.4	2.1051	27.53 (h)	Transceiver Spurious Emissions	Pass
2.5	2.1055	27.54	Frequency Stability	Pass
-	-	15.111	Receiver Spurious Emissions	<Note 1>
Note 1. Not applicable as this is a transceiver				

1.3 PRODUCT INFORMATION

1.3.1 Technical Description

The Equipment Under Test (EUT) is an Octasic Inc. Base Station unit working in supports 5G in the C Band (3900 MHz – 3980 MHz).

Economic Area basis, see § 27.6(m), as follows:

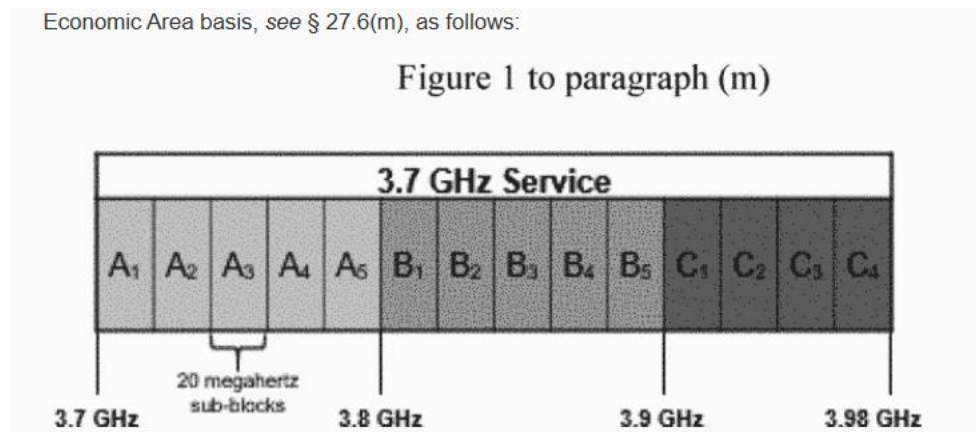

The channel configuration is as follows:

Channels	Frequency (MHz)	Power (dBm)
Bottom Channels	3905	30
	3925	47
	3930	47
Middle	3935	47
Top	3940	47
	3945	47
	3975	30

A full technical description can be found in the Manufacturer's documentation.



1.3.2 Configuration Description

The CBRSYS6800 supports Single Mode operation from a single port configuration.

The CBRSYS6800 supports 5G in the C Band (3900 MHz – 3980 MHz).

TX test cases: Maximum Conducted Output Power, Spurious Emissions at Antenna Terminals (± 1 MHz) and Conducted Spurious Emissions, measurements were performed on the RF Port. The test limits shown are representative of the worst case. All testing was performed with the EUT transmitting at maximum RF power unless as designated setting by client, otherwise stated.

The EUT was powered via a 120V 60Hz power supply.

Channel Configurations: 5G in Band C (3905 MHz – 3975 MHz)

RAT	Band	No. Of Carriers	Modulation	Carrier Bandwidth	Carrier Frequency Configuration (MHz)		
					Bottom/ B_{RFBW} (MHz)	Middle/ M_{RFBW} (MHz)	Top/ T_{RFBW} (MHz)
5G	n77/n78	1	QPSK	10 MHz	3905,3925,3930	3935	3940, 3945, 3975



1.4 DECLARATION OF BUILD STATUS

MAIN EUT	
MANUFACTURING DESCRIPTION	CBRSYS6800
MANUFACTURER	Octasic inc.
TYPE	Portable Base Station Unit with Transportable Amplification Unit
PART NUMBER(S)	CBRSYS6208-PE-4E CBRREF6602-WW500-EE-5U
SERIAL NUMBER(S)	CBRSYS6200: K-21572 CBRRFE6600: K-21570
HARDWARE VERSION(S)	CBRSYS6200 Rev1 CBRREF6600 Rev1
SOFTWARE VERSIONS(S)	CBRREF6600 03.00.00-B0004-DEV CBRSYS6800 03.03.00-D1115\HFPBU_RDT_EXE-02.01.01-B6
TRANSMITTER OPERATING RANGE	3300-4200MHz
RECEIVER OPERATING RANGE	3300-4200MHz
COUNTRY OF ORIGIN	CBRSYS6000 - India CBRRFE6400 - Canada
EMISSION DESIGNATOR(S): (i.e. G1D, GXW)	W7D
MODULATION TYPES: (i.e. GMSK, QPSK)	5G: QPSK
HIGHEST INTERNALLY GENERATED FREQUENCY	4200MHz
OUTPUT POWER (W or dBm)	47dBm
FCC ID	2AQSOCBRSYS6800
TECHNICAL DESCRIPTION (a brief description of the intended use and operation)	The Transportable Amplification Unit (TAU) is a powerful multiband RF front-end (RFE) designed for use as a Transportable Amplification Unit (TAU) in conjunction with a Portable Base station Unit (PBU). The EUT fits in a standard 19" 6U rack.

Equipment Under Test (EUT)

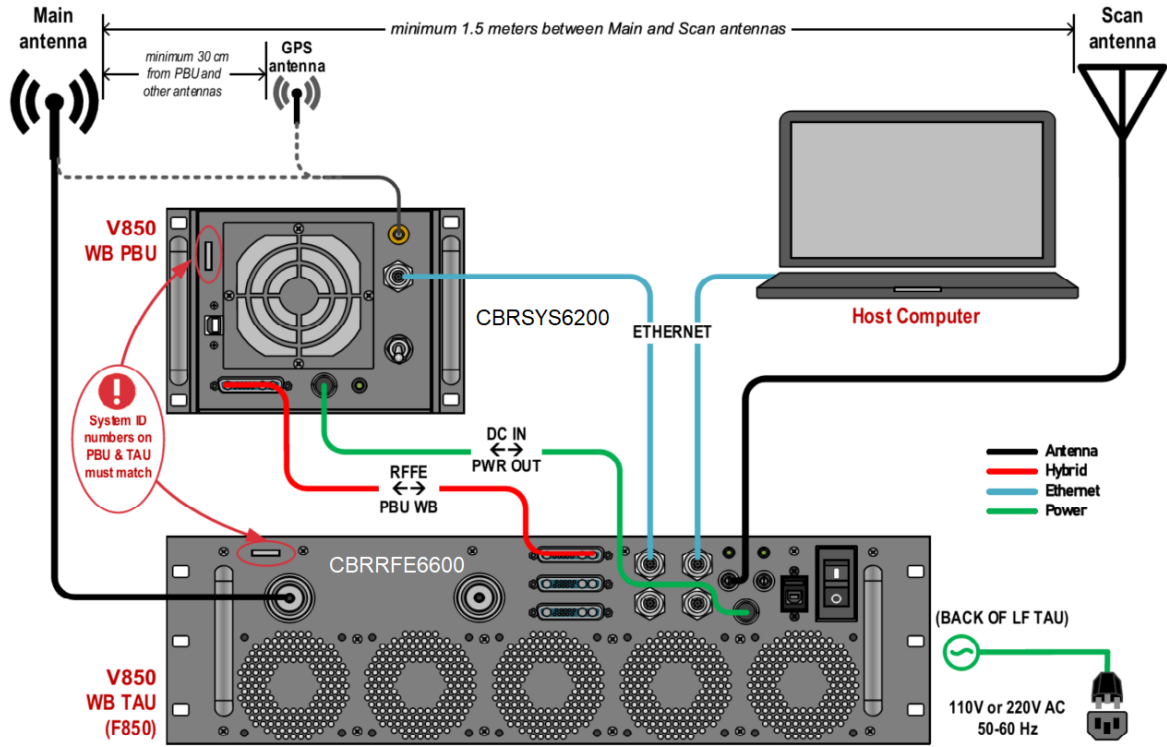
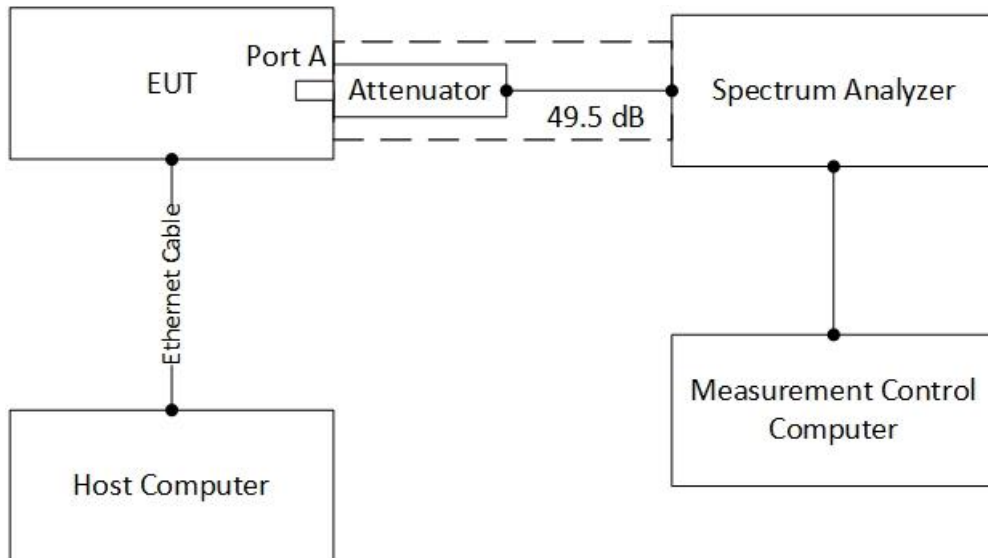

Figure 1. Connection Diagram of CBRSYS6800 (CBRSYS6200 & CBRRFE6600)

1.5 GENERAL TEST SETUP





1.6 TEST CONDITIONS

For all tests the EUT was set up in accordance with the relevant test standard and to represent typical operating conditions. Tests were applied with the EUT situated as described in the Test Method for each Test.

The EUT was powered from 120Vac supply.

FCC Measurement Facility Registration Number: CA4810

Under our group A2LA Accreditation, TÜV SÜD conducted the following tests at Ericsson, Ottawa.

Test Name	Name of Test Specialist(s)
Maximum Peak Output Power and Peak to Average Ratio - Conducted	Scott Drysdale Jose Martinez
Occupied Bandwidth	Scott Drysdale Jose Martinez
Band Edge	Scott Drysdale Jose Martinez
Transmitter Spurious Emissions	Scott Drysdale Jose Martinez
Frequency Stability	Scott Drysdale Jose Martinez

1.7 DEVIATION FROM THE STANDARD

No deviations from the applicable test standards or test plan were made during testing.

1.8 MODIFICATION RECORD

No modifications were made to the EUT during testing.

1.9 ADDITIONAL INFORMATION

The CBRSYS6200 Portable Base station Unit (PBU) is multi-channel, software-defined radio (SDR) based base station system for wireless applications like Search and Rescue (S&R) and Network in a Box (NIB). It is designed to fit in a standard 19" 3U rack—two PBUs can be fit in a standard 3U rack and ships in a ruggedized 3U rackmount case, ready for vehicular deployment.

Depending on band configuration it can support up to 8 bands. It has a high sensitivity multiband receiver and an interference mitigation and suppression mechanism to maintain sensitivity in the presence of interference. The transmitter can transmit up to 100W peak per band.



SECTION 2

TEST DETAILS



2.1 MAXIMUM PEAK OUTPUT POWER AND PEAK TO AVERAGE RATIO - CONDUCTED

2.1.1 Specification Reference

FCC CFR 47 Part 2, Clause 2.1046
FCC CFR 47 Part 27, Clause 27.50

2.1.2 Date of Test and Modification State

07 April 2021 - Modification State 0

2.1.3 Test Equipment Used

The major items of test equipment used for the above tests are identified in Section 3.1.

2.1.4 Environmental Conditions

Ambient Temperature	23.1°C
Relative Humidity	13.4%

2.1.5 Test Method

All measurements were made in accordance with FCC KDB 971168 D01, clause 5.2.1. The attenuation value in Figure 1 and used throughout is 49.5 dB.

Measurements were performed with a Spectrum Analyser using the Band Power measurement function. The detector was set to RMS with an RBW of at least 1 % of the carrier bandwidth and a VBW of at least 3 times the RBW. The integration bandwidth was configured to be wider than the total bandwidth of the carrier or combinations of carriers, (multi-carrier). Using a sweep time of auto, measurements were performed over 200 samples, with the average measurement recorded.

Due to Average measurements being recorded, an additional Peak to Average power ratio (PAPR) measurement was made. This was achieved using the CCDF function of the Spectrum Analyser with the RBW being set to a value wider than the largest signal being measured – in this case – 20MHz.

The EUT was configured to transmit on maximum power on the configurations defined in the tables below.

The peak to average ratio measurement was performed at the conducted ports of the EUT. The spectrum analyzer's Complementary Cumulative Distribution Function (CCDF) was used and 0.1% probability value recorded.

The RMS Power and Peak to Average Ratio were measured and recorded with the results being compared with the limits.



2.1.6 Test Results

2.1.6.1 Bottom Channel – 3905 MHz

Maximum Target Output Power: 30 dBm

Antenna	Channel	Frequency (MHz)	Modulation	Carrier Bandwidth	Peak to Average Ratio (PAPR) / Output Power		
					PAPR	Average Power	
					dB	dBm/15MHz	dBm/MHz <Note 1>
A	B: Bottom	3905	5G: QPSK	10.0 MHz	8.68	29.57	20.24

Note 1. dBm / MHz = dBm/15MHz – 10xLog (OBW) and OBW as per [section 2.2](#)

Antenna Port A Carrier Power - Modulation 5G: QPSK - Carrier Bandwidth 10.0 MHz – Channel Position: 3905 MHz

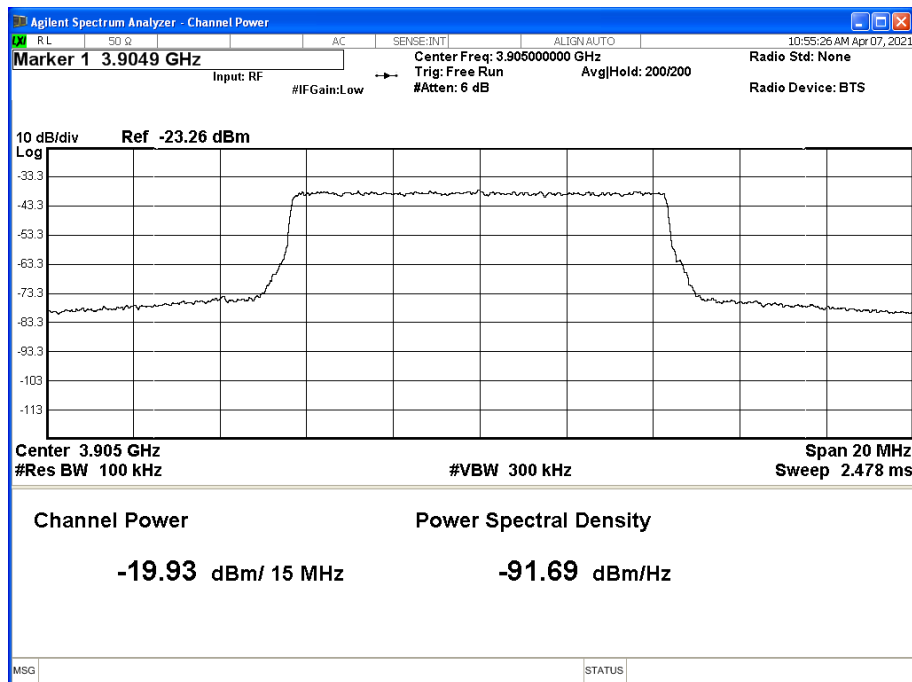

Calculation: 49.5 dB – 19.93 dBm = 29.57 dBm.



Antenna Port A Pk-Av Ratio - Modulation 5G: QPSK - Carrier Bandwidth 10.0 MHz - Channel Position: 3905 MHz

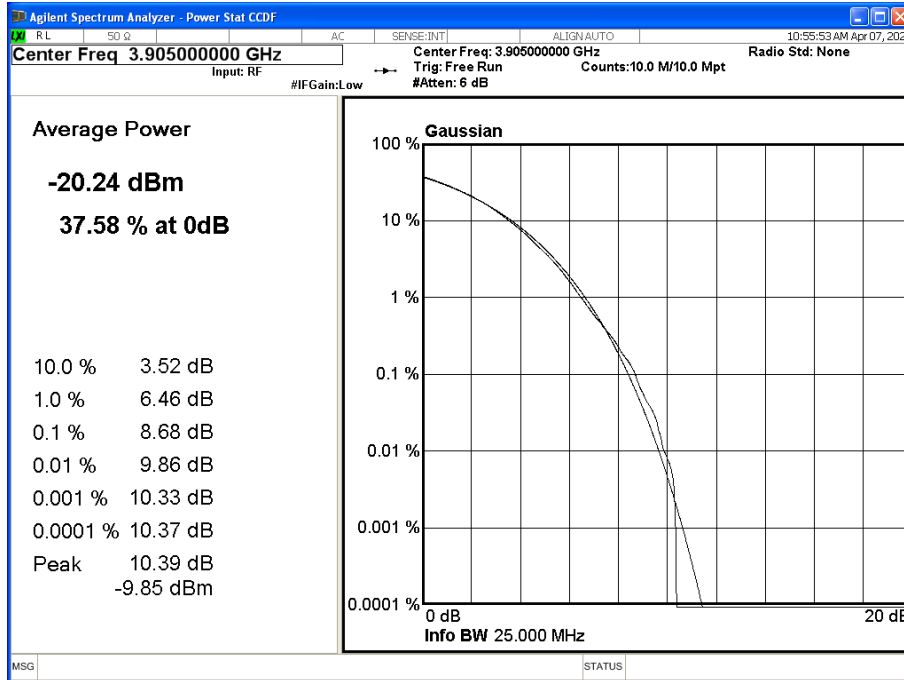

Calculation: Limit (13 dB) – 0.1% (8.68 dB) = 4.32 dB: Pass.

Antenna Port A PSD - Modulation 5G: QPSK - Carrier Bandwidth 10.0 MHz – Channel Position: 3905 MHz

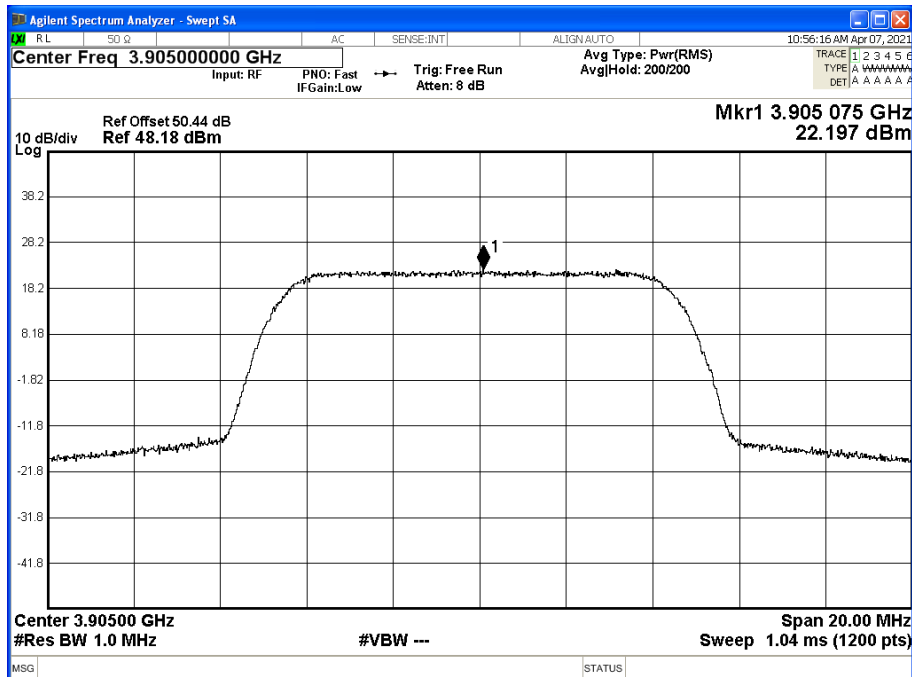



2.1.6.2 Bottom Channel: 3925 MHz

Maximum Target Output Power: 47 dBm

Antenna	Channel	Frequency (MHz)	Modulation	Carrier Bandwidth	Peak to Average Ratio (PAPR) / Output Power		
					PAPR	Average Power	
					dB	dBm/15MHz	dBm/MHz <Note 1>
A	B: Bottom	3925	5G: QPSK	10.0 MHz	7.07	46.11	36.77

Note 1. dBm / MHz = dBm/15MHz – 10xLog (OBW) and OBW.

Antenna Port A Carrier Power - Modulation 5G: QPSK - Carrier Bandwidth 10.0 MHz – Channel Position: 3925 MHz

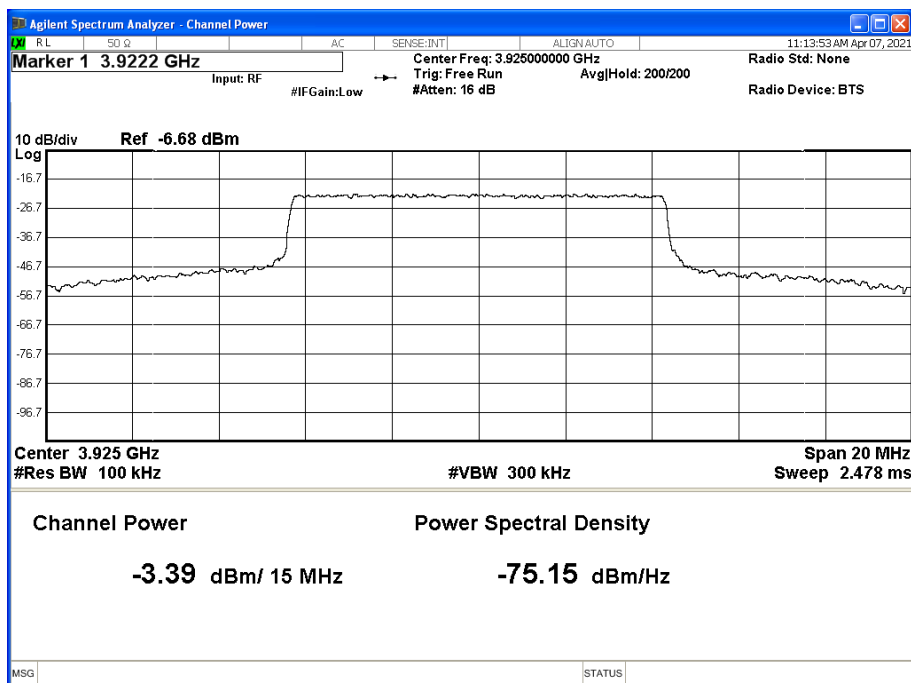

Calculation: 49.5 dB – 3.39 dBm = 46.11 dBm.



Antenna Port A Pk-Av Ratio - Modulation 5G: QPSK - Carrier Bandwidth 10.0 MHz - Channel Position: 3925 MHz

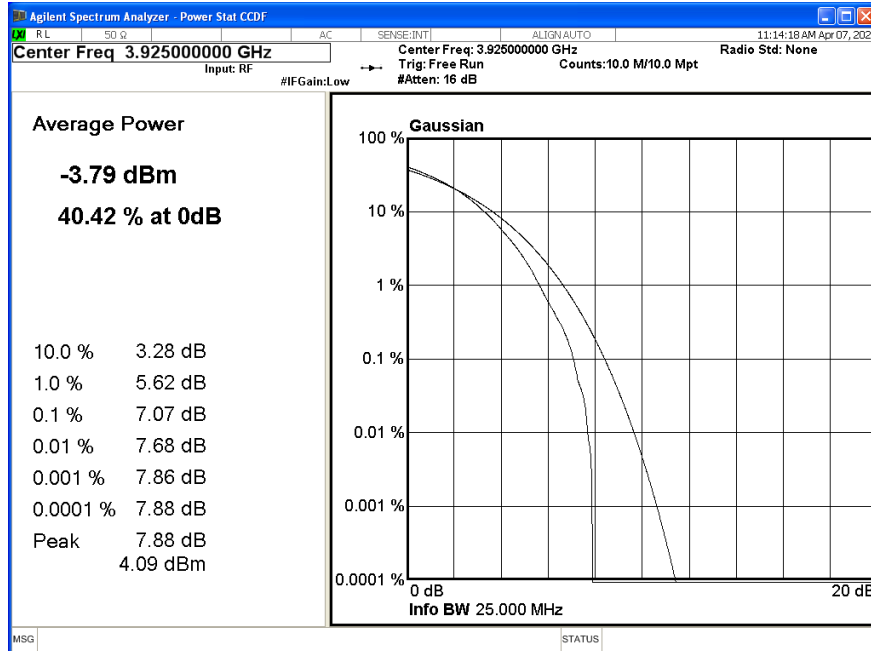

Calculation: Limit (13 dB) – 0.1% (7.07 dB) = 5.93 dB: Pass.

Antenna Port A PSD - Modulation 5G: QPSK - Carrier Bandwidth 10.0 MHz – Channel Position: 3925 MHz

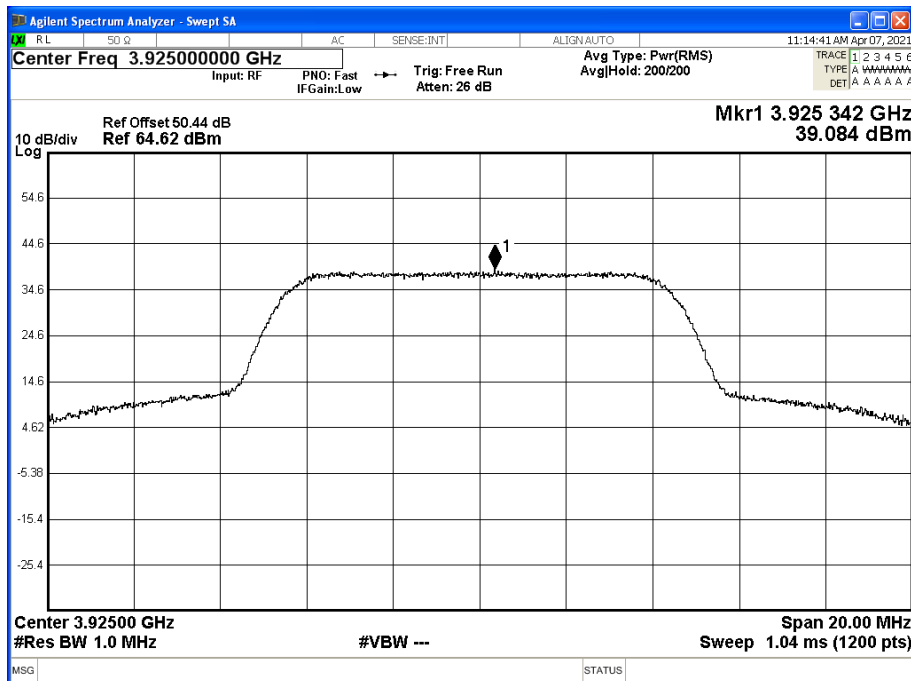



2.1.6.3 Bottom Channel: 3930 MHz

Maximum Target Output Power: 47 dBm

Antenna	Channel	Frequency (MHz)	Modulation	Carrier Bandwidth	Peak to Average Ratio (PAPR) / Output Power		
					PAPR	Average Power	
					dB	dBm/15MHz	dBm/MHz <Note 1>
A	B: Bottom	3930	5G: QPSK	10.0 MHz	7.04	46.02	36.68

Note 1. dBm / MHz = dBm/15MHz – 10xLog (OBW) and OBW.

Antenna Port A Carrier Power - Modulation 5G: QPSK - Carrier Bandwidth 10.0 MHz – Channel Position: 3930 MHz

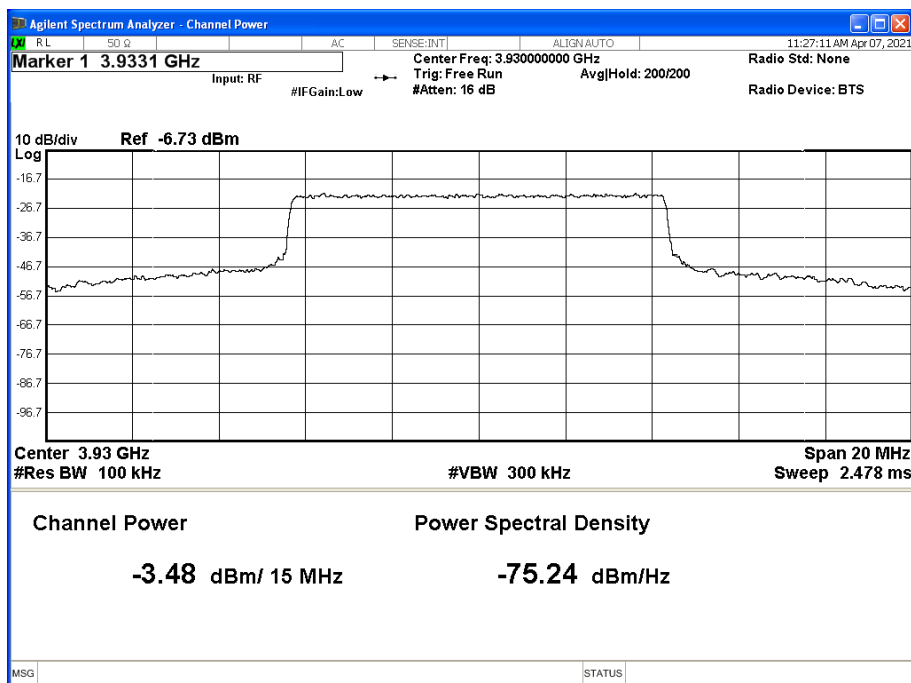

Calculation: 49.5 dB – 3.48 dBm = 46.02 dBm.



Antenna Port A Pk-Av Ratio - Modulation 5G: QPSK - Carrier Bandwidth 10.0 MHz - Channel Position: 3930 MHz

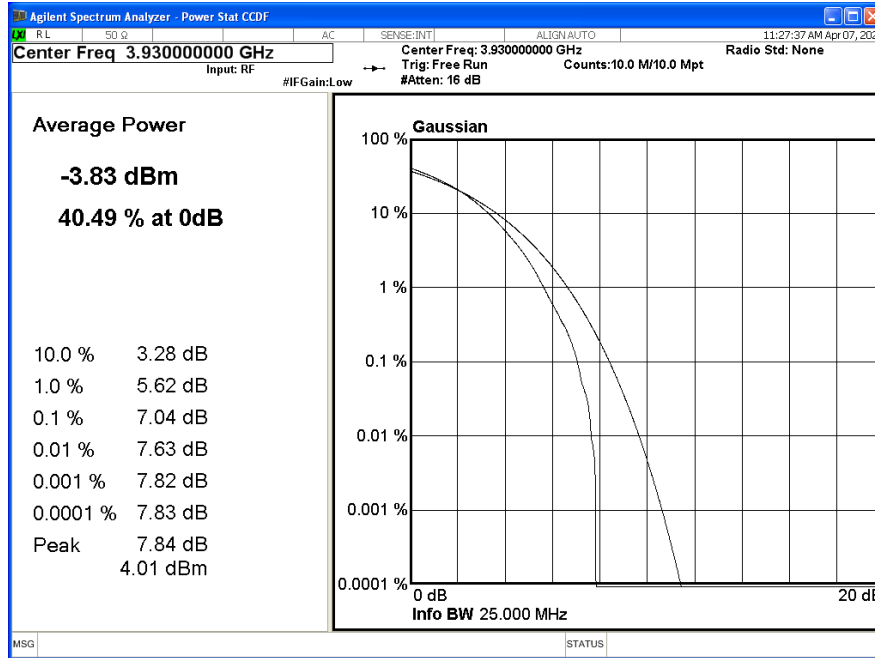

Calculation: Limit (13 dB) – 0.1% (7.04 dB) = 5.96 dB: Pass

Antenna Port A PSD - Modulation 5G: QPSK - Carrier Bandwidth 10.0 MHz – Channel Position: 3930 MHz

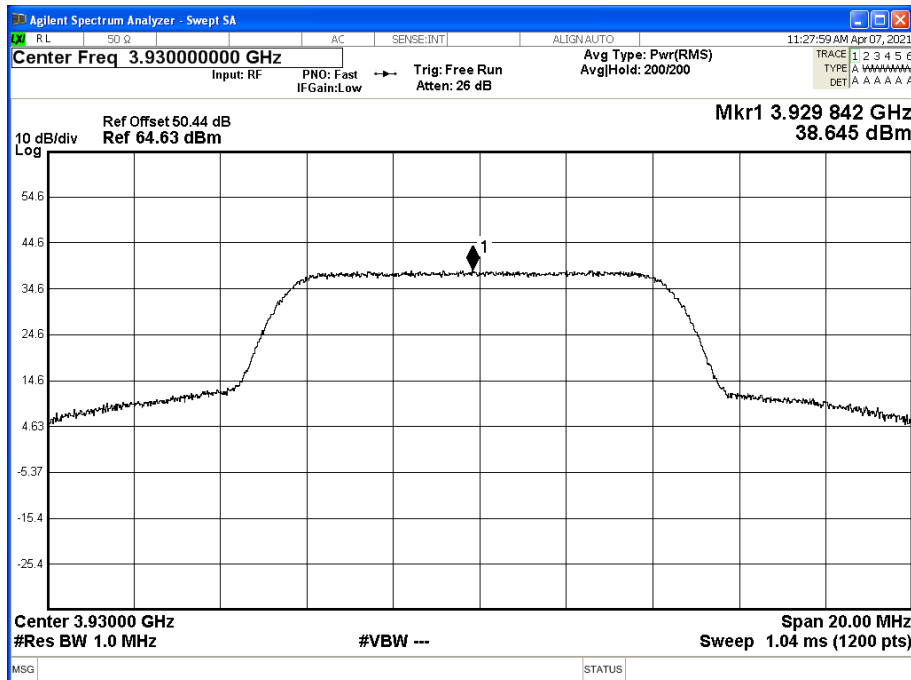



2.1.6.4 Middle Channel: 3935 MHz

Maximum Target Output Power: 47 dBm

Antenna	Channel	Frequency (MHz)	Modulation	Carrier Bandwidth	Peak to Average Ratio (PAPR) / Output Power		
					PAPR	Average Power	
					dB	dBm/15MHz	dBm/MHz <Note 1>
A	M: Middle	3935	5G: QPSK	10.0 MHz	6.95	46.1	36.76

Note 1. dBm / MHz = dBm/15MHz – 10xLog (OBW) and OBW as per [section 2.2](#)

Antenna Port A Carrier Power - Modulation 5G: QPSK - Carrier Bandwidth 10.0 MHz – Channel Position: 3935 MHz

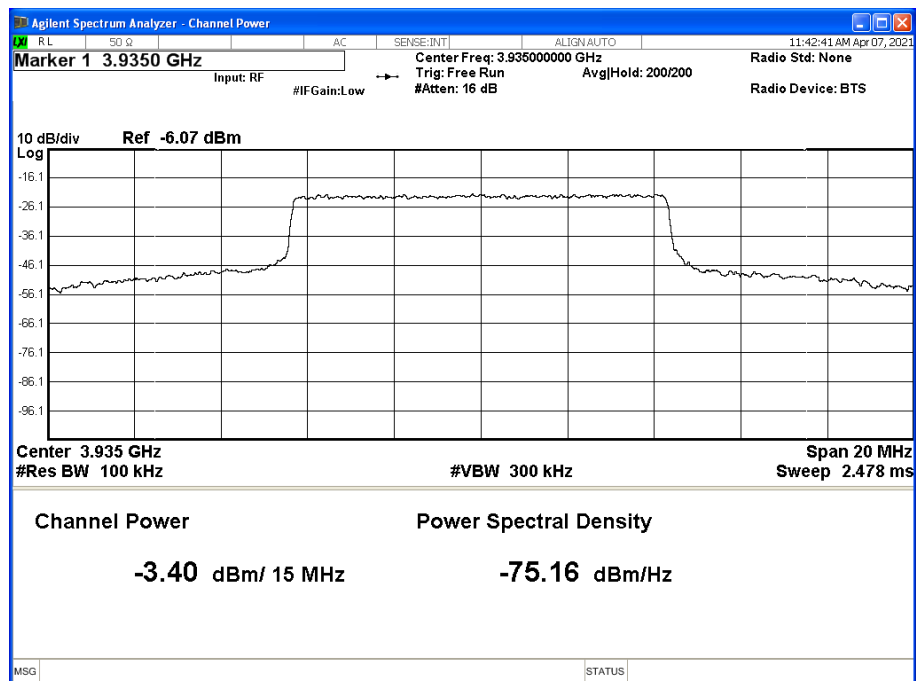

Calculation: 49.5 dB – 3.40 dBm = 46.1 dBm.



Antenna Port A Pk-Av Ratio - Modulation 5G: QPSK - Carrier Bandwidth 10.0 MHz - Channel Position: 3935 MHz

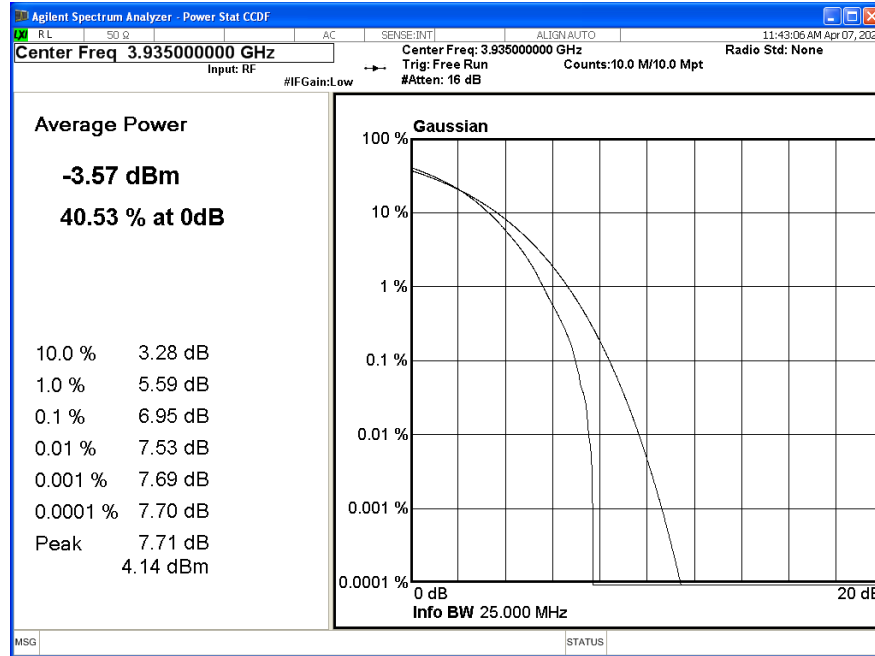

Calculation: Limit (13 dB) – 0.1% (6.95 dB) = 6.05 dB: Pass

Antenna Port A PSD - Modulation 5G: QPSK - Carrier Bandwidth 10.0 MHz – Channel Position : 3935 MHz

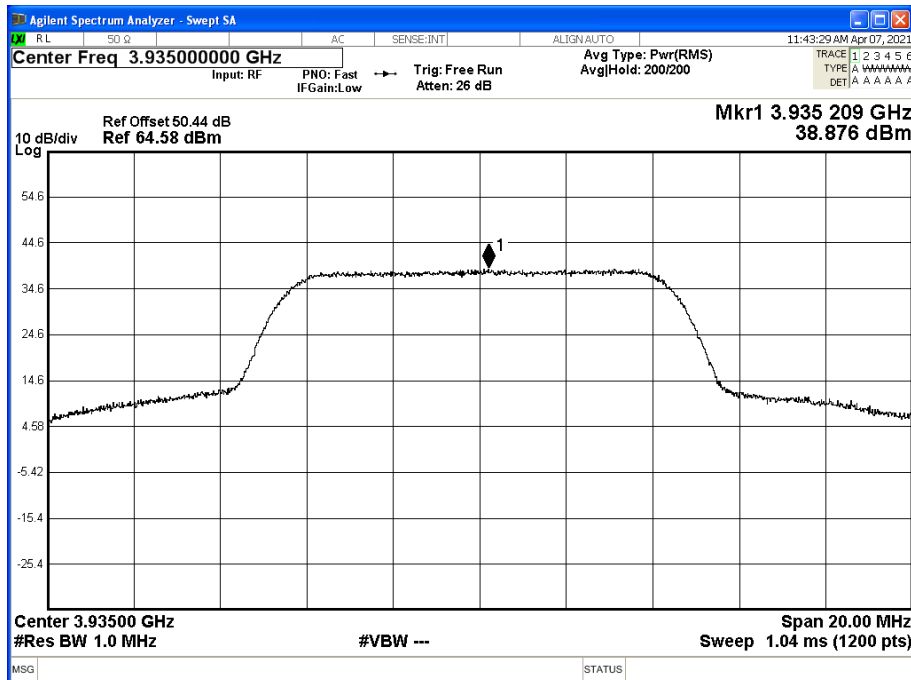



2.1.6.5 Top Channel: 3940 MHz

Maximum Target Output Power: 47 dBm

Antenna	Channel	Frequency (MHz)	Modulation	Carrier Bandwidth	Peak to Average Ratio (PAPR) / Output Power		
					PAPR	Average Power	
					dB	dBm/15MHz	dBm/MHz <Note 1>
A	T: Top	3940	5G: QPSK	10.0 MHz	6.84	46.51	37.17

Note 1. dBm / MHz = dBm/15MHz – 10xLog (OBW).

Antenna Port A Carrier Power - Modulation 5G: QPSK - Carrier Bandwidth 10.0 MHz – Channel Position : 3940 MHz

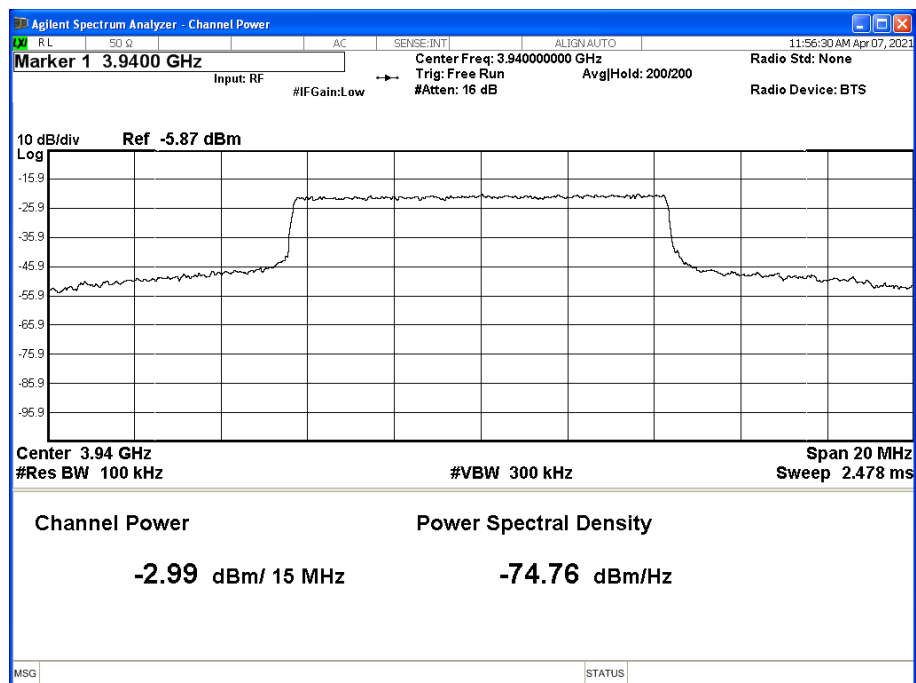

Calculation: 49.5 dB – 2.99 dBm = 46.51 dBm.



Antenna Port A Pk-Av Ratio - Modulation 5G: QPSK - Carrier Bandwidth 10.0 MHz - Channel Position: 3940 MHz

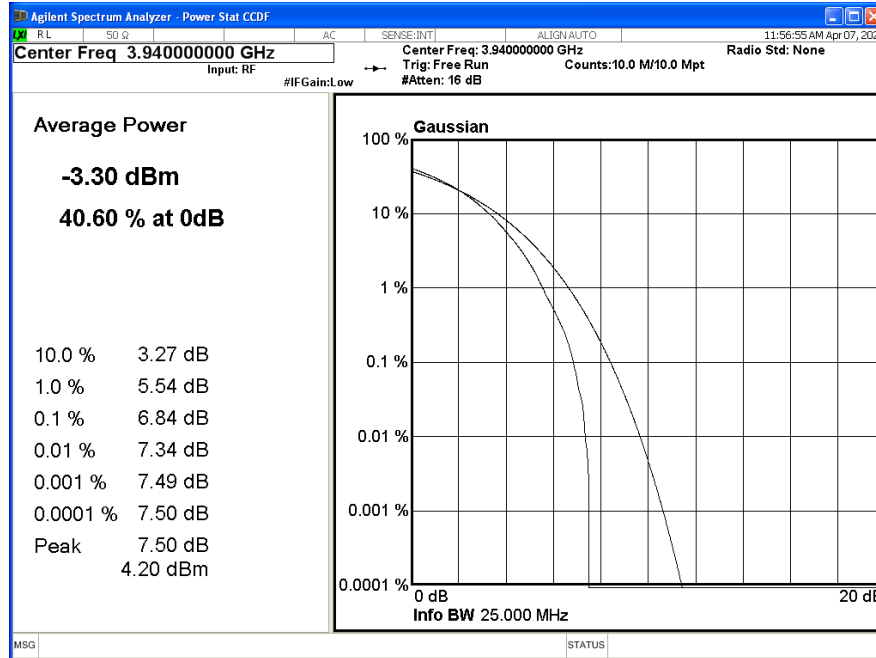

Calculation. Limit (13 dB) – 0.1% (6.84 dB) = 6.16 dB: Pass

Antenna Port A PSD - Modulation 5G: QPSK - Carrier Bandwidth 10.0 MHz – Channel Position : 3940 MHz

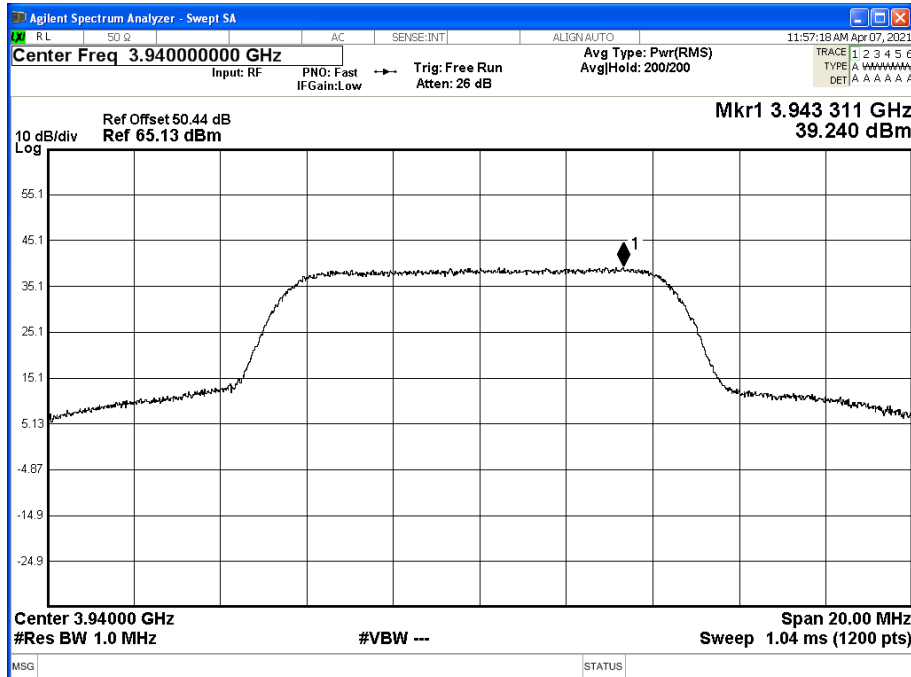



2.1.6.6 Top Channel: 3945 MHz

Maximum Target Output Power: 47 dBm

Antenna	Channel	Frequency (MHz)	Modulation	Carrier Bandwidth	Peak to Average Ratio (PAPR) / Output Power		
					PAPR	Average Power	
					dB	dBm/15MHz	dBm/MHz <Note 1>
A	T: Top	3940	5G: QPSK	10.0 MHz	6.96	46.28	36.94

Note 1. dBm / MHz = dBm/15MHz – 10xLog (OBW).

Antenna Port A Carrier Power - Modulation 5G: QPSK - Carrier Bandwidth 10.0 MHz – Channel Position : 3945 MHz

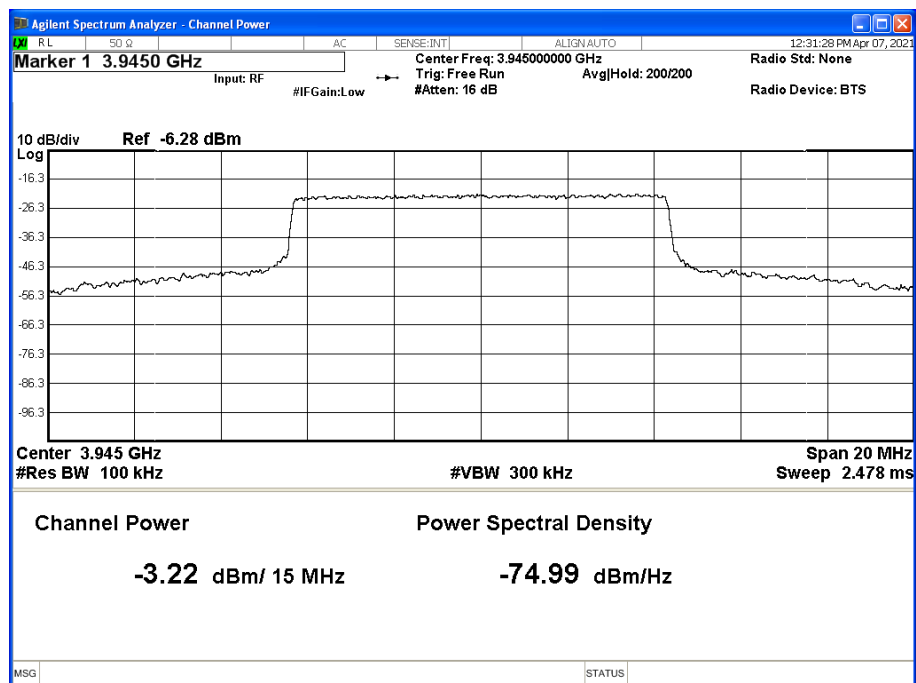

Calculation. 49.5 dB – 3.22 dBm = 46.28 dBm.



Antenna Port A Pk-Av Ratio - Modulation 5G: QPSK - Carrier Bandwidth 10.0 MHz - Channel Position : 3945 MHz

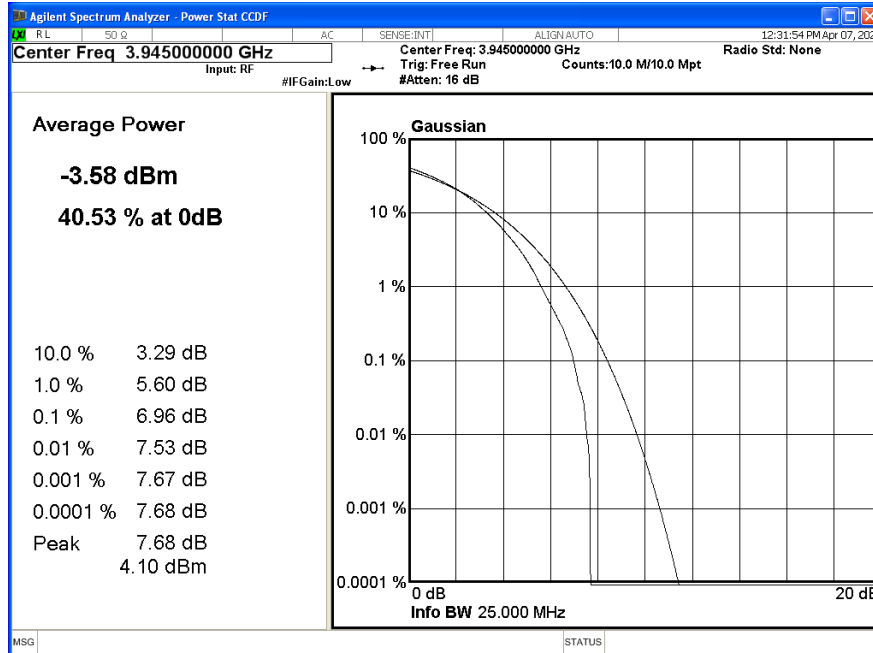

Calculation. Limit (13 dB) – 0.1% (6.96 dB) = 6.04 dB: Pass.

Antenna Port A PSD - Modulation 5G: QPSK - Carrier Bandwidth 10.0 MHz – Channel Position : 3945 MHz

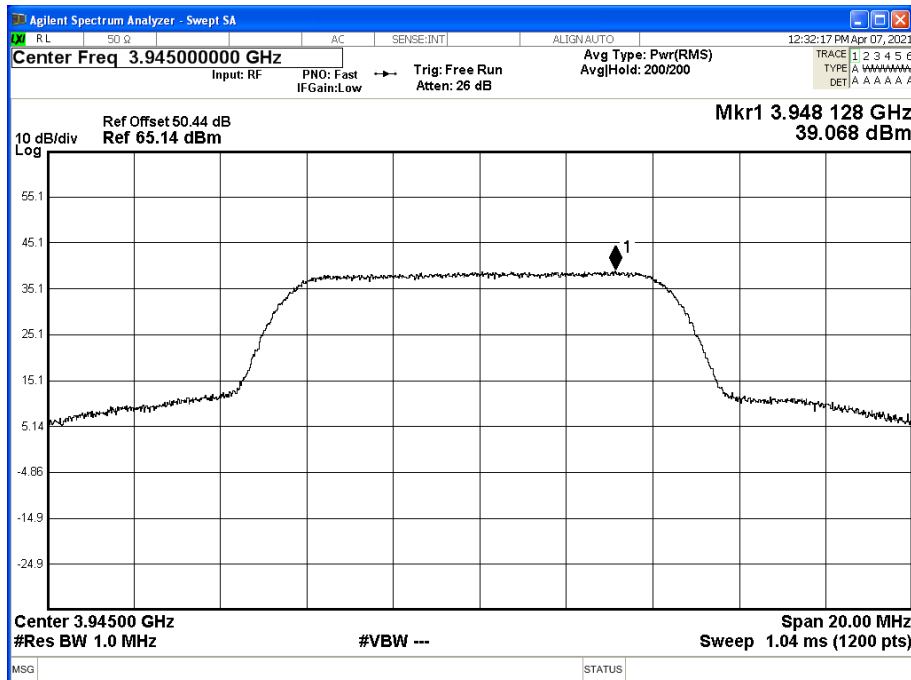



2.1.6.7 Top Channel – 3975 MHz

Maximum Target Output Power: 30 dBm

Antenna	Channel	Frequency (MHz)	Modulation	Carrier Bandwidth	Peak to Average Ratio (PAPR) / Output Power		
					PAPR	Average Power	
					dB	dBm/15MHz	dBm/MHz <Note 1>
A	T: Top	3940	5G: QPSK	10.0 MHz	8.67	29.44	20.10

Note 1. dBm / MHz = dBm/15MHz – 10xLog (OBW) and OBW as per [section 2.2](#)

Antenna Port A Carrier Power - Modulation 5G: QPSK - Carrier Bandwidth 10.0 MHz – Channel Position: 3975 MHz

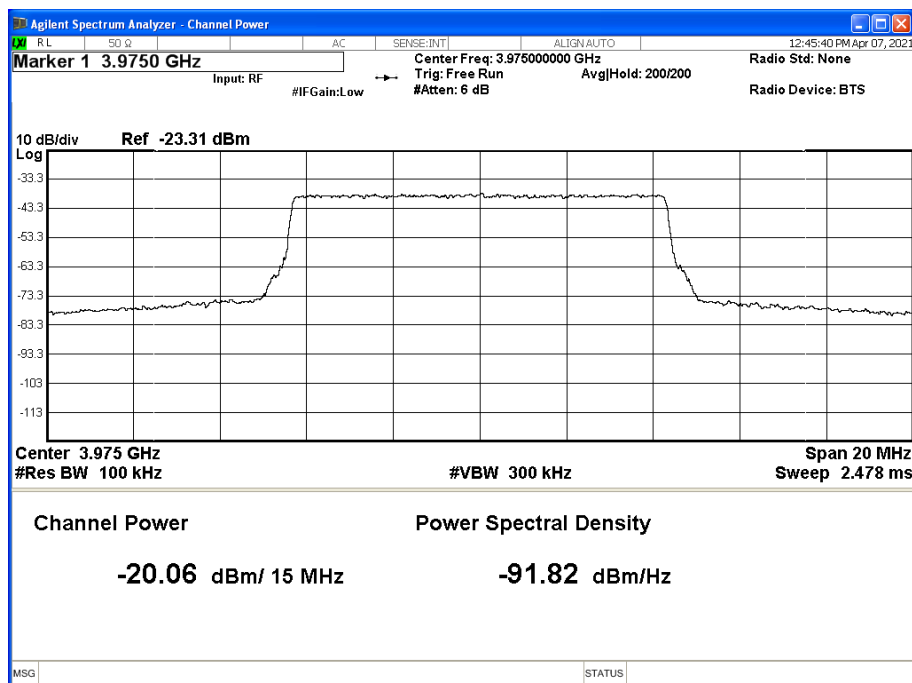

Calculation. 49.5 dB – 20.06 dBm = 29.44 dBm.



Antenna Port A Pk-Av Ratio - Modulation 5G: QPSK - Carrier Bandwidth 10.0 MHz - Channel Position : 3975 MHz

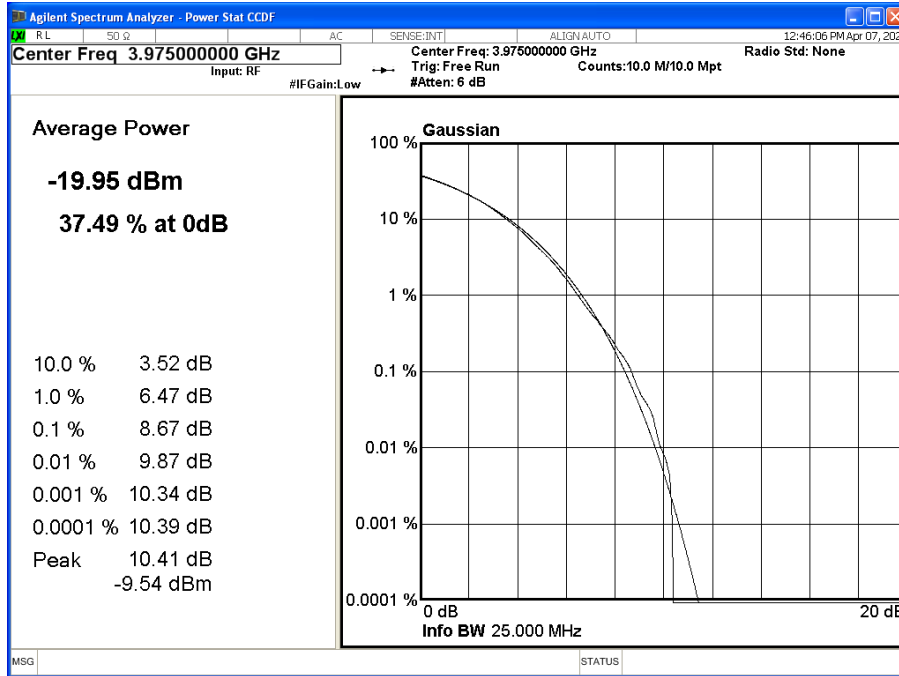

Calculation. Limit (13 dB) – 0.1% (8.67 dB) = 4.33 dB: Pass

Antenna Port A PSD - Modulation 5G: QPSK - Carrier Bandwidth 10.0 MHz – Channel Position: 3975 MHz

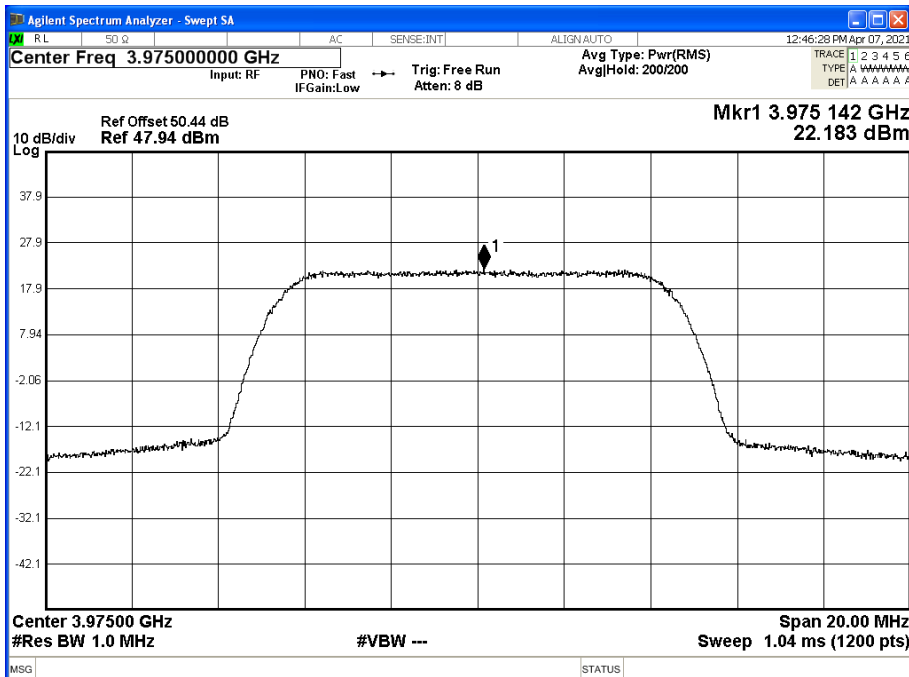



Limits	
Peak Power	$\leq 1640 \text{ W/MHz}$ or $\leq +62.15 \text{ dBm}$
Peak to Average Ratio	13 dB



2.2 OCCUPIED BANDWIDTH

2.2.1 Specification Reference

FCC CFR 47 Part 2, Clause 2.1049
FCC CFR 47 Part 27, Clause 27.53

2.2.2 Date of Test and Modification State

07 April 2021 - Modification State 0

2.2.3 Test Equipment Used

The major items of test equipment used for the above tests are identified in Section 3.1.

2.2.4 Environmental Conditions

Ambient Temperature	23.1°C
Relative Humidity	13.4%

2.2.5 Test Method

All measurements were made in accordance with FCC KDB 971168 D01.



2.2.6 Test Results

Maximum Output Power: B: 30 dBm; M: 47 dBm and T: 30 dBm. The worst-case scenario of middle channels is provided.

2.2.6.1 Bottom Channel – 3905 MHz

Modulation	Carrier Bandwidth	Result (MHz)	
		Channel Bandwidth	-26 dB Bandwidth
5G: QPSK	5G: 10.0 MHz	8.57	9.37

Antenna A – 5G, Bandwidth QPSK – Channel B: 3905 MHz

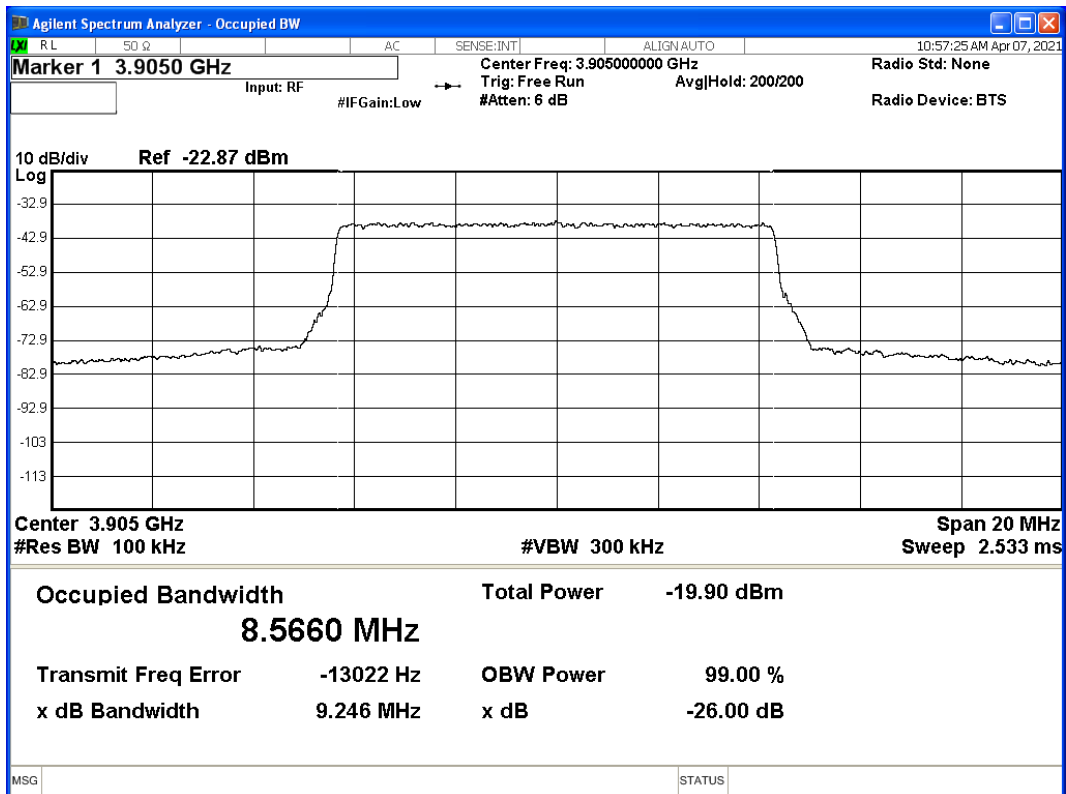



2.2.6.2 Middle Channel: 3935 MHz

Modulation	Carrier Bandwidth	Result (MHz)	
		Channel Bandwidth	
		Occupied Bandwidth	-26 dB Bandwidth
5G: QPSK	5G: 10.0 MHz	8.6	10.27

Antenna A – 5G, Bandwidth QPSK – Channel B: 3955 MHz

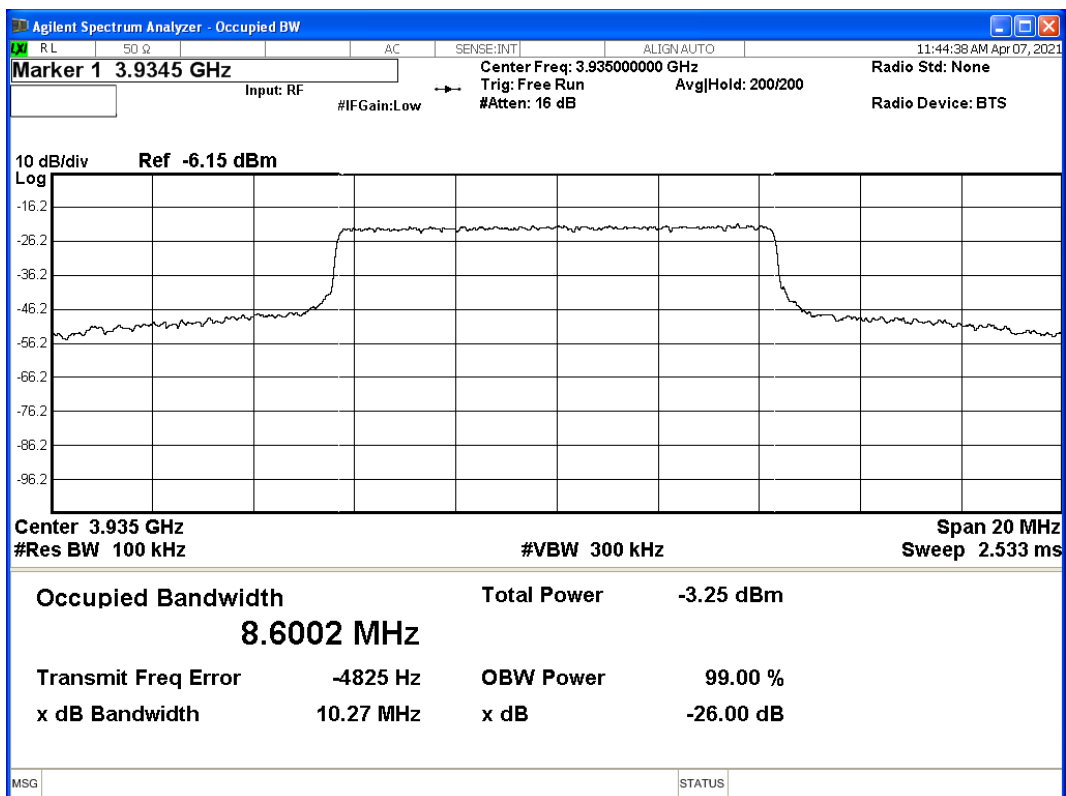



2.2.6.1 Top Channel – 3975 MHz

Modulation	Carrier Bandwidth	Result (MHz)	
		Channel Bandwidth	
		Occupied Bandwidth	-26 dB Bandwidth
5G: QPSK	5G: 10.0 MHz	8.57	9.37

Antenna A – 5G, Bandwidth QPSK – Channel B: 3975 MHz

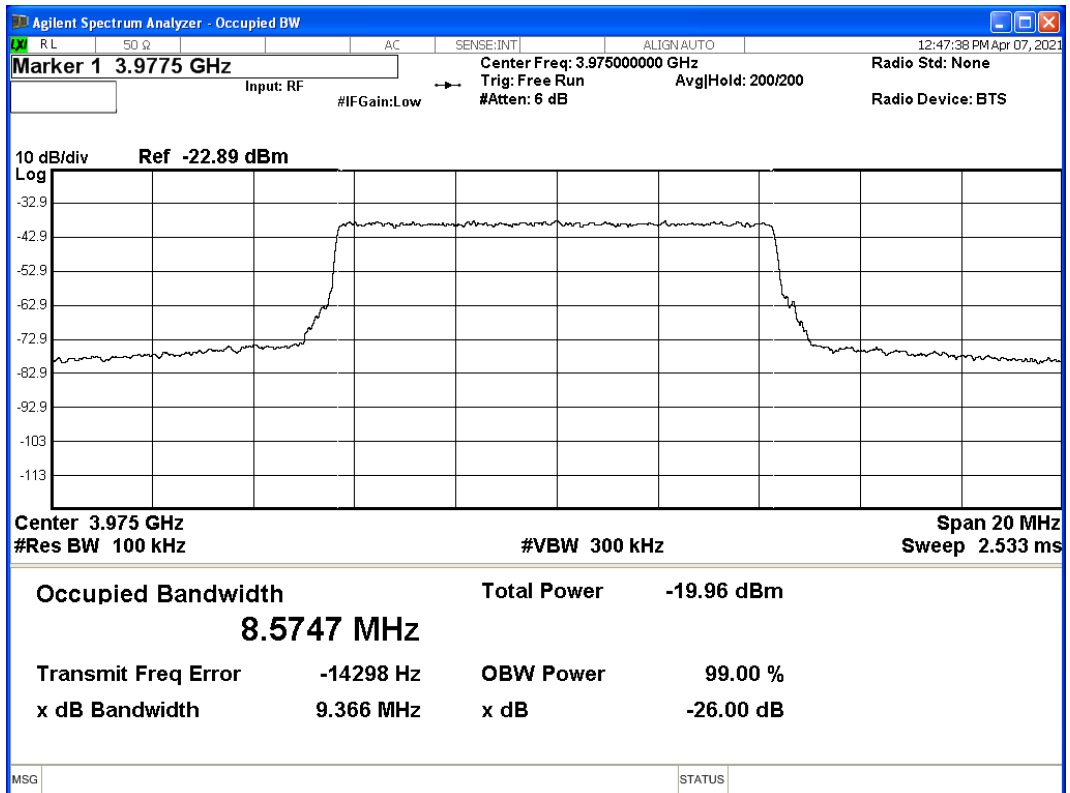



2.3 BAND EDGE

2.3.1 Specification Reference

FCC CFR 47 Part 2, Clause 2.1051
FCC CFR 47 Part 27, Clause 27.53 (h)

2.3.2 Date of Test and Modification State

7 April 2021 - Modification State 0

2.3.3 Test Equipment Used

The major items of test equipment used for the above tests are identified in Section 3.1.

2.3.4 Environmental Conditions

Ambient Temperature	23.1°C
Relative Humidity	13.4%

2.3.5 Test Method

All measurements were made in accordance with FCC KDB 971168 D01, clause 6. The EUT was connected to a Spectrum Analyser via an attenuator and switching box. The pathloss between the EUT and the Spectrum Analyser was measured using a Network Analyser. The measured path loss was entered as a Reference Level Offset in the Spectrum Analyser. The Spectrum Analyser RBW was adjusted to be at least 1% of the measured 26dB Bandwidth. Using an RMS detector, the frequency spectrum up to 1MHz away from the Band Edge was Investigated. The EUT has one transmit port, testing was performed on this port with a test limit of $43+10\log(P) = -13$ dBm.



2.3.6 Test Results

Maximum Output Power: B: 30 dBm; M: 47 dBm and T: 30 dBm. The band edges of middle channels were determined and only the worst scenario is provided.

2.3.6.1 Bottom Channel – 3905 MHz

Maximum Target output Power: 30 dBm

Modulation	Carrier Bandwidth	Band Edge (MHz)
		Channel Position B:
5G: QPSK	5G: 10.0 MHz	3905

Antenna A – 5G Modulation QPSK - Carrier Bandwidth 10.0 MHz - Channel Position: 3905 MHz

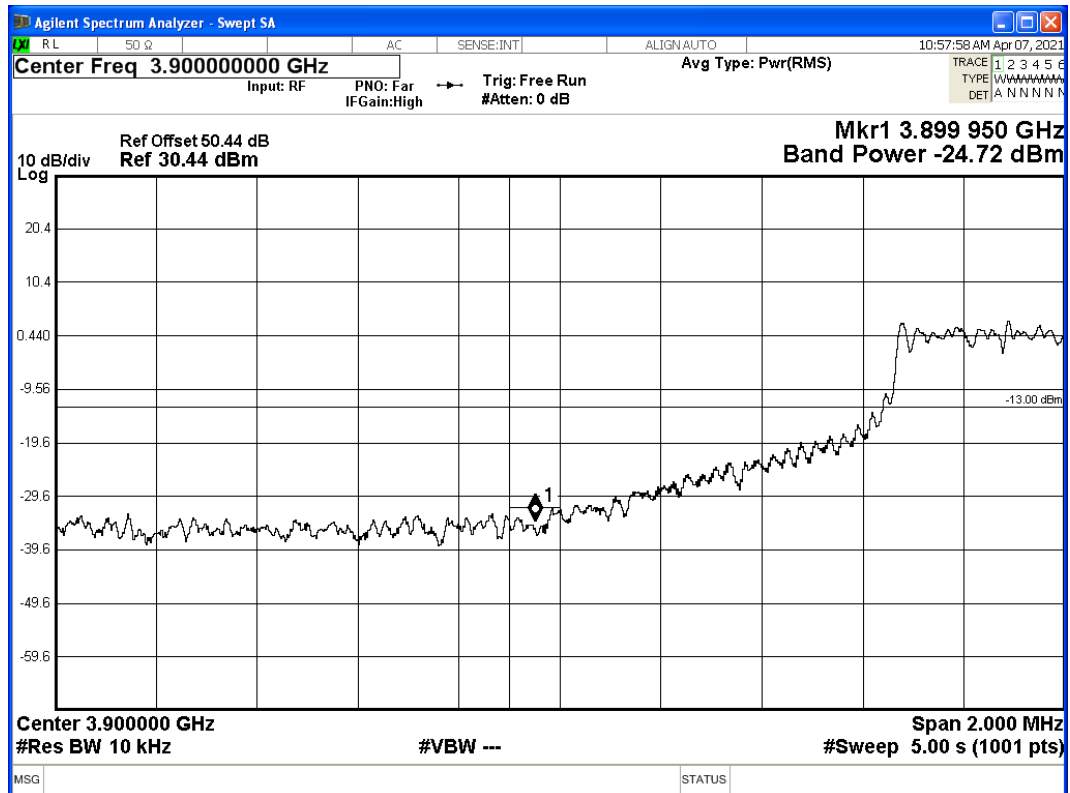

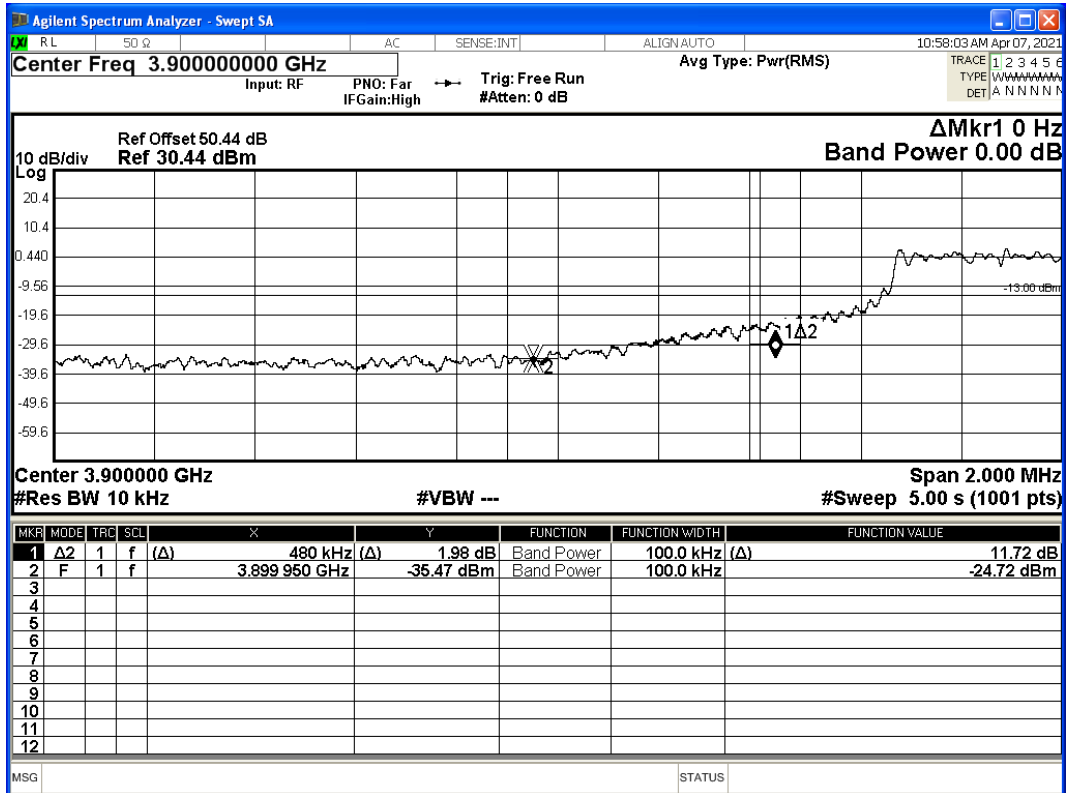



2.3.6.2 Bottom Channel – 3925 MHz

Maximum Target output Power: 47 dBm

Modulation	Carrier Bandwidth	Band Edge (MHz)
		Channel Position B:
5G: QPSK	5G: 10.0 MHz	3925

Antenna A: 5G Modulation QPSK - Carrier Bandwidth 10.0 MHz - Channel Position M: 3925 MHz

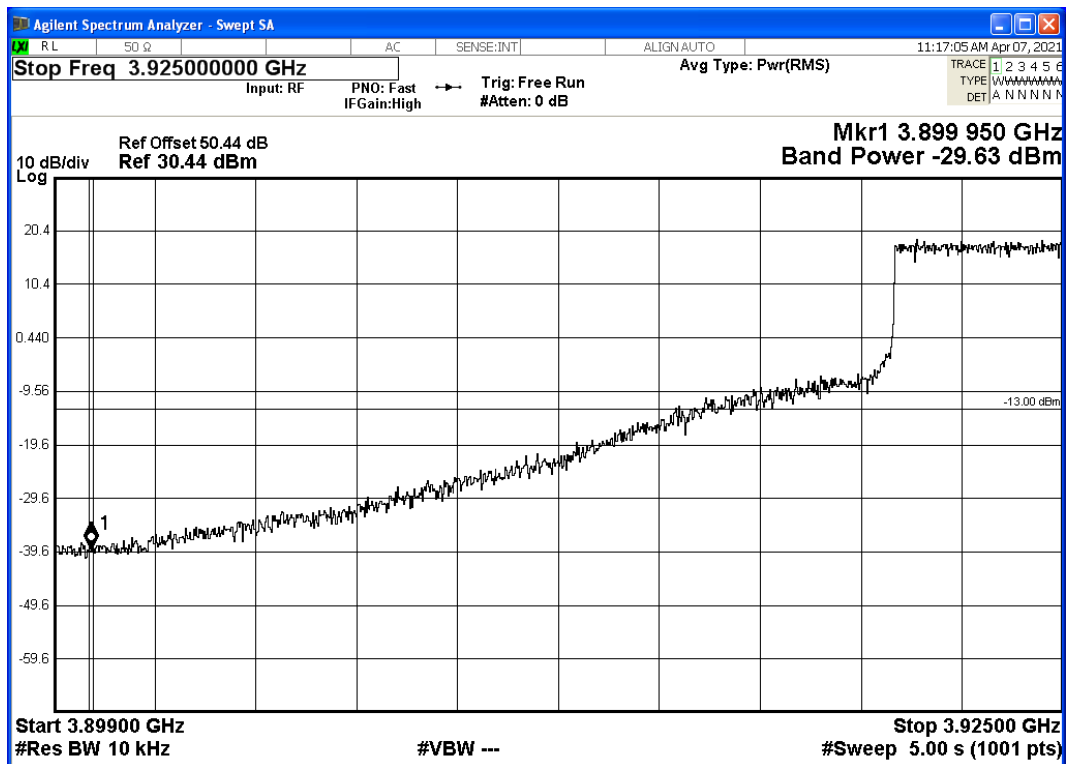



2.3.6.3 Bottom Channel: 3930 MHz

Maximum Target output Power: 47 dBm

Modulation	Carrier Bandwidth	Band Edge (MHz)
		Channel Position B:
5G: QPSK	5G: 10.0 MHz	3930

Antenna A: 5G Modulation QPSK - Carrier Bandwidth 10.0 MHz - Channel Position: 3930 MHz

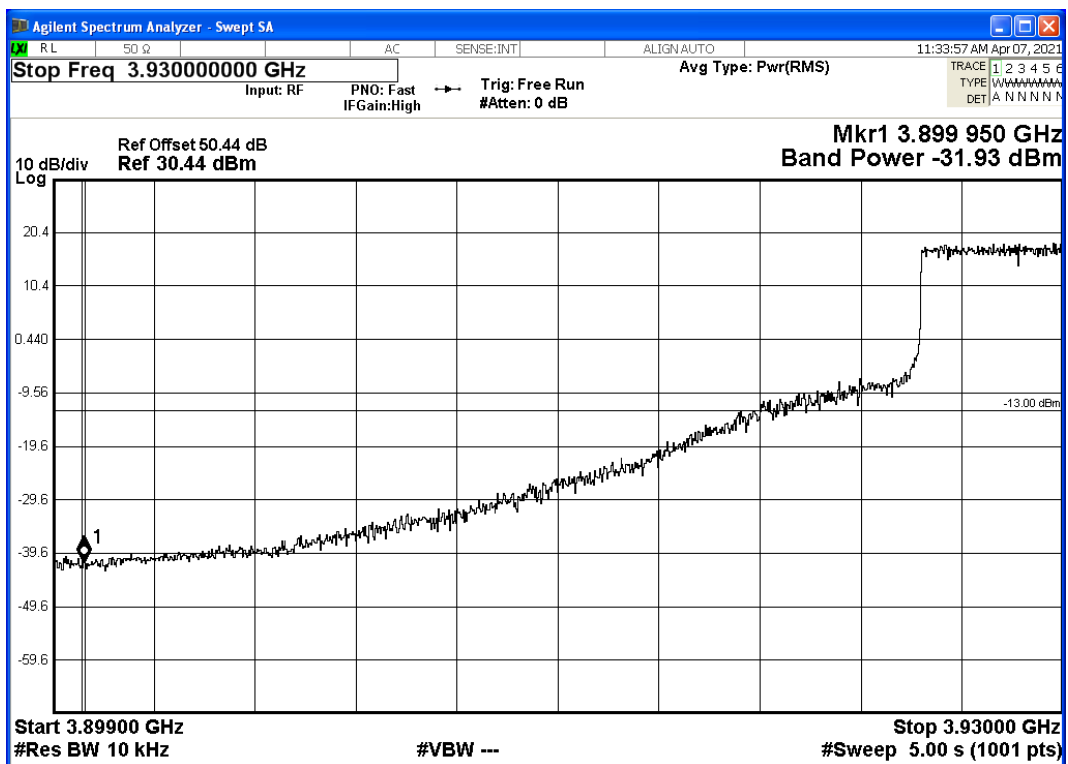



extended down to 9 kHz following the limits provided in 15.209”

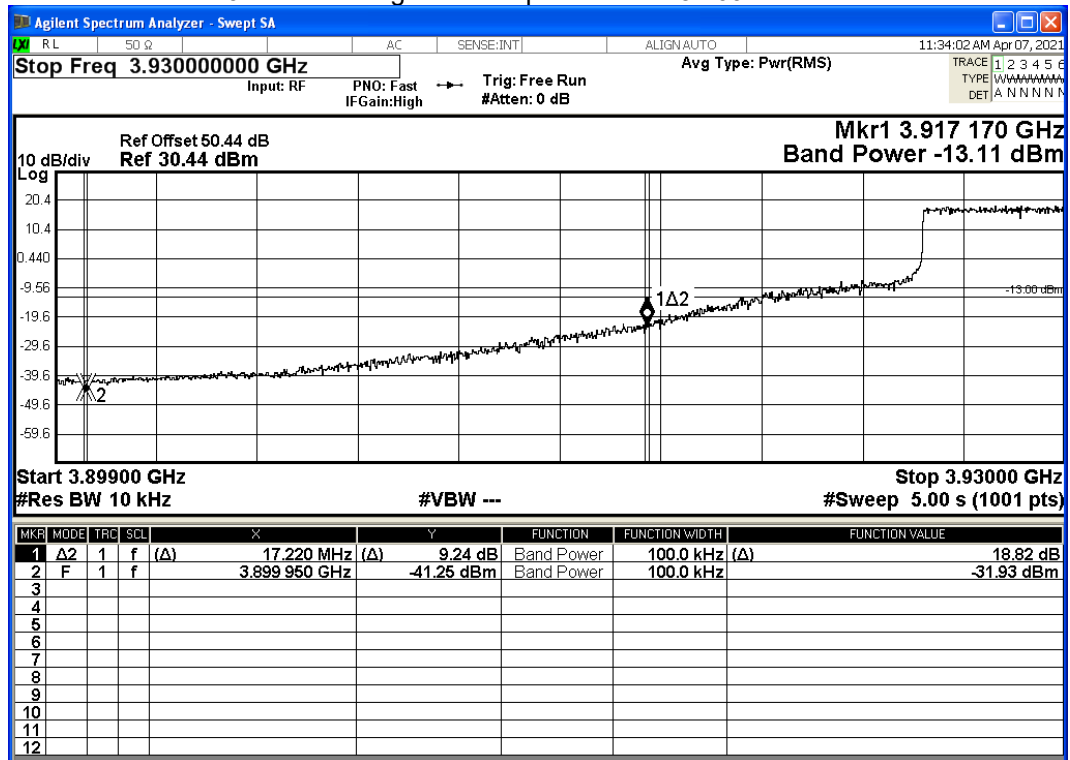



2.3.6.1 Middle Channel: 3935 MHz

Maximum Target output Power: 47 dBm

Modulation	Carrier Bandwidth	Band Edge (MHz)
		Channel Position M:
5G: QPSK	5G: 10.0 MHz	3935

Antenna A: 5G Modulation QPSK - Carrier Bandwidth 10.0 MHz - Channel Position: 3935 MHz

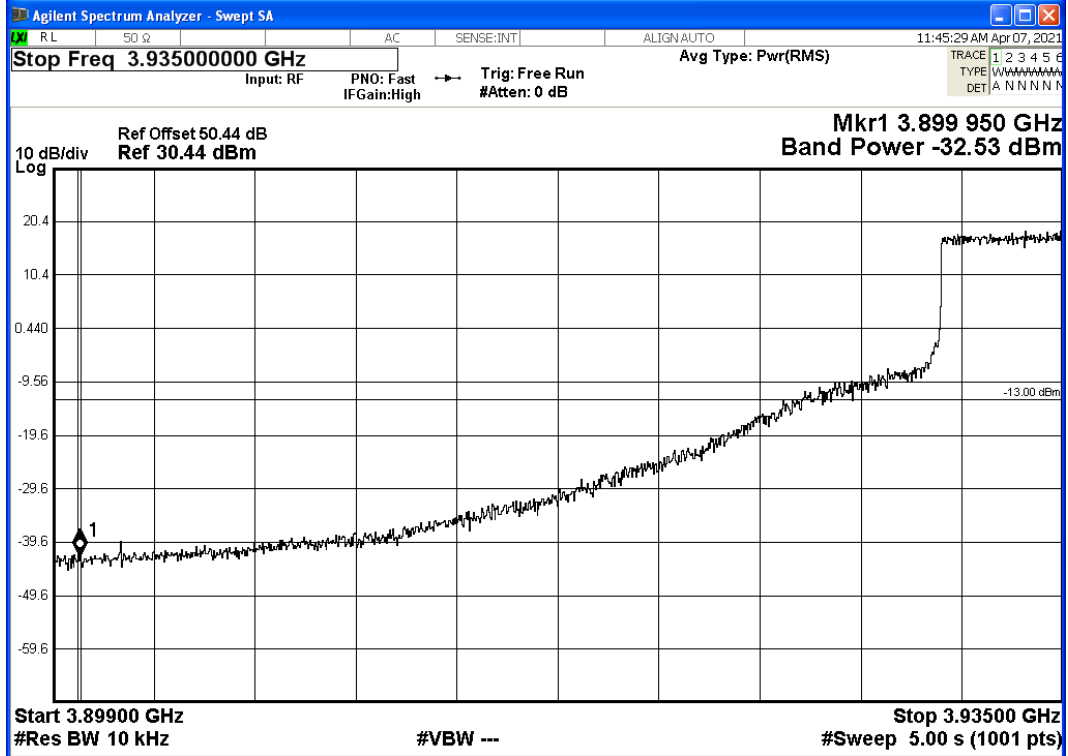

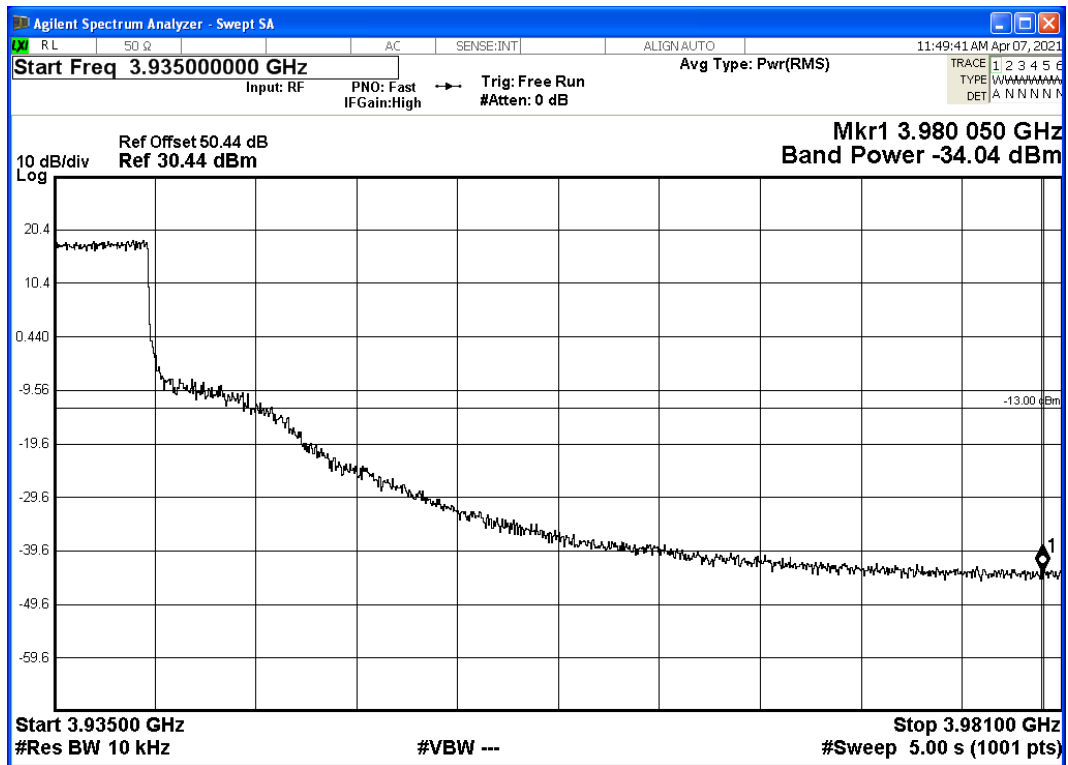

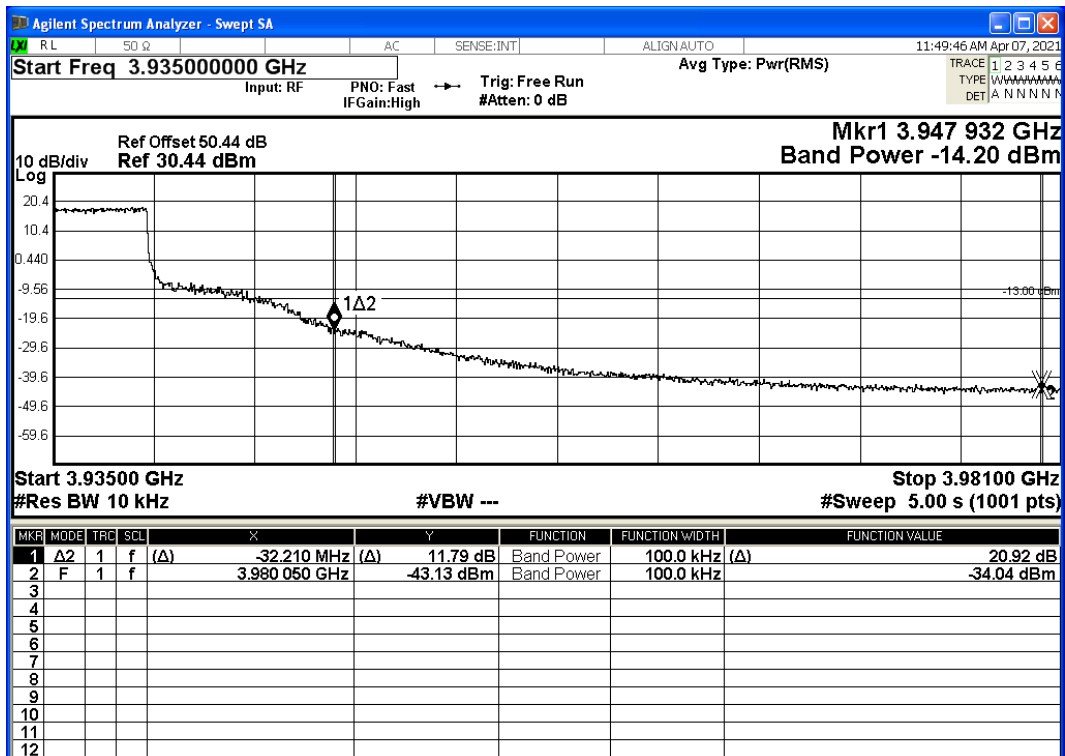
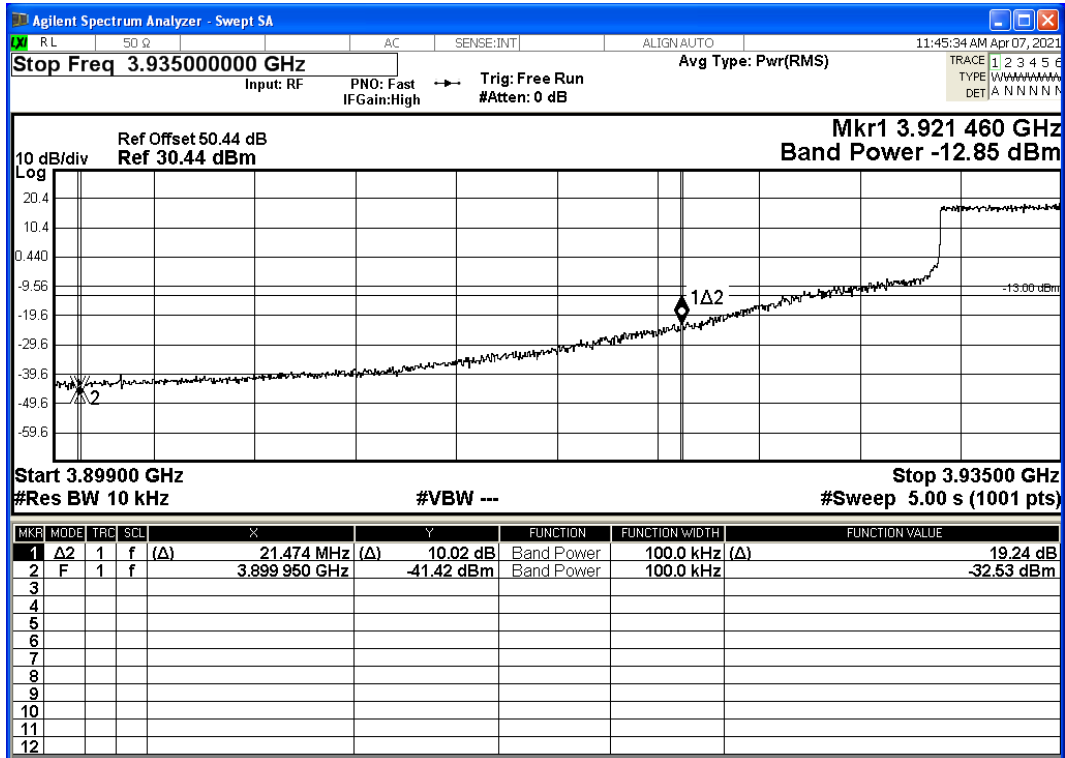



2.3.6.2 Top Channel: 3940 MHz

Maximum Target output Power: 47 dBm

Modulation	Carrier Bandwidth	Band Edge (MHz)
		Channel Position T:
5G: QPSK	5G: 10.0 MHz	3940

Antenna A: 5G Modulation QPSK - Carrier Bandwidth 10.0 MHz - Channel Position: 3940 MHz

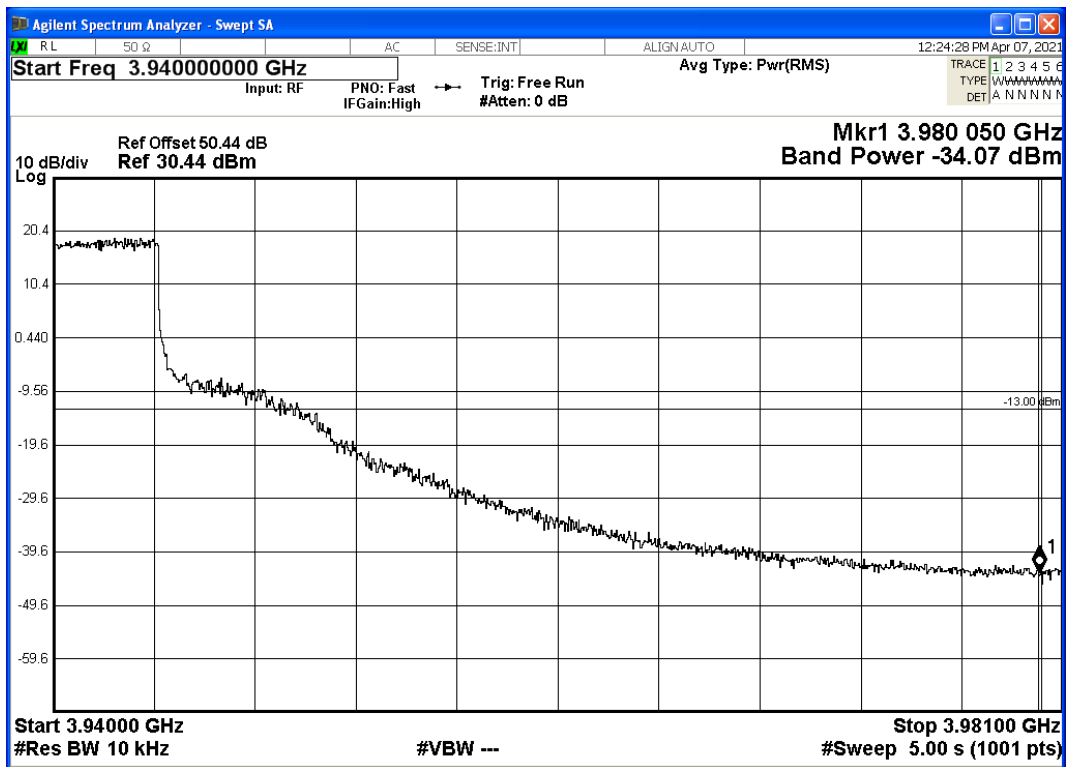

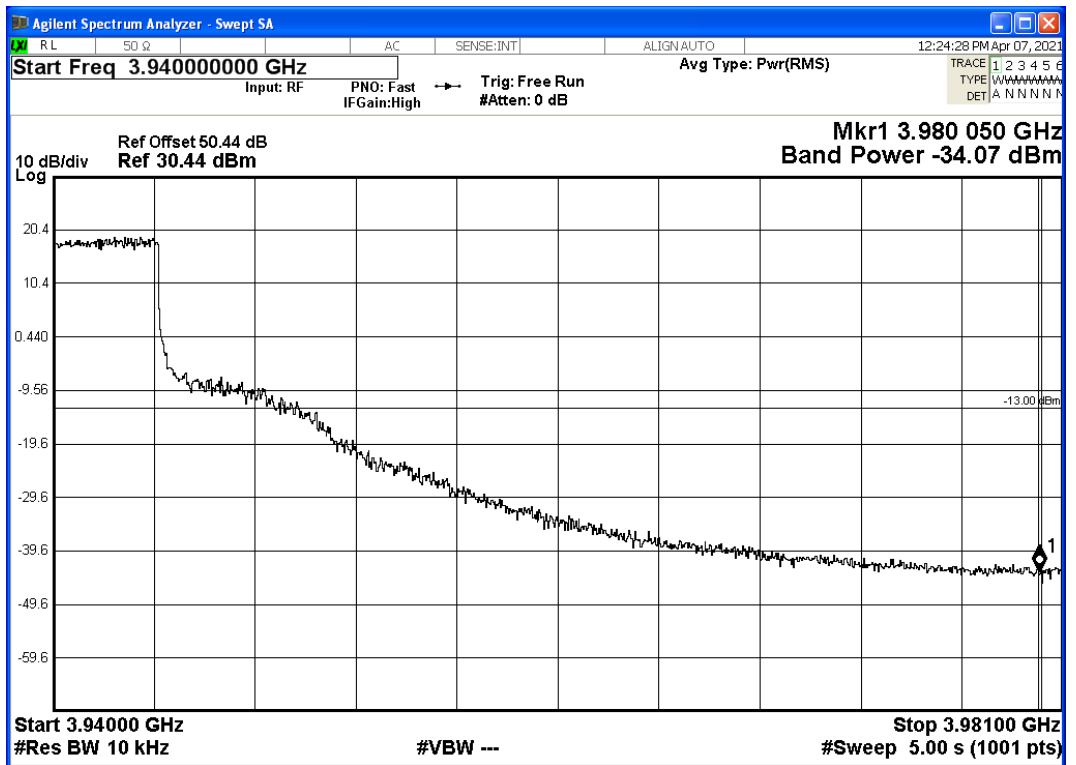



2.3.6.3 Top Channel: 3945 MHz

Maximum Target output Power: 47 dBm

Modulation	Carrier Bandwidth	Band Edge (MHz)
		Channel Position T:
5G: QPSK	5G: 10.0 MHz	3945

Antenna A: 5G Modulation QPSK - Carrier Bandwidth 10.0 MHz - Channel Position: 3945 MHz

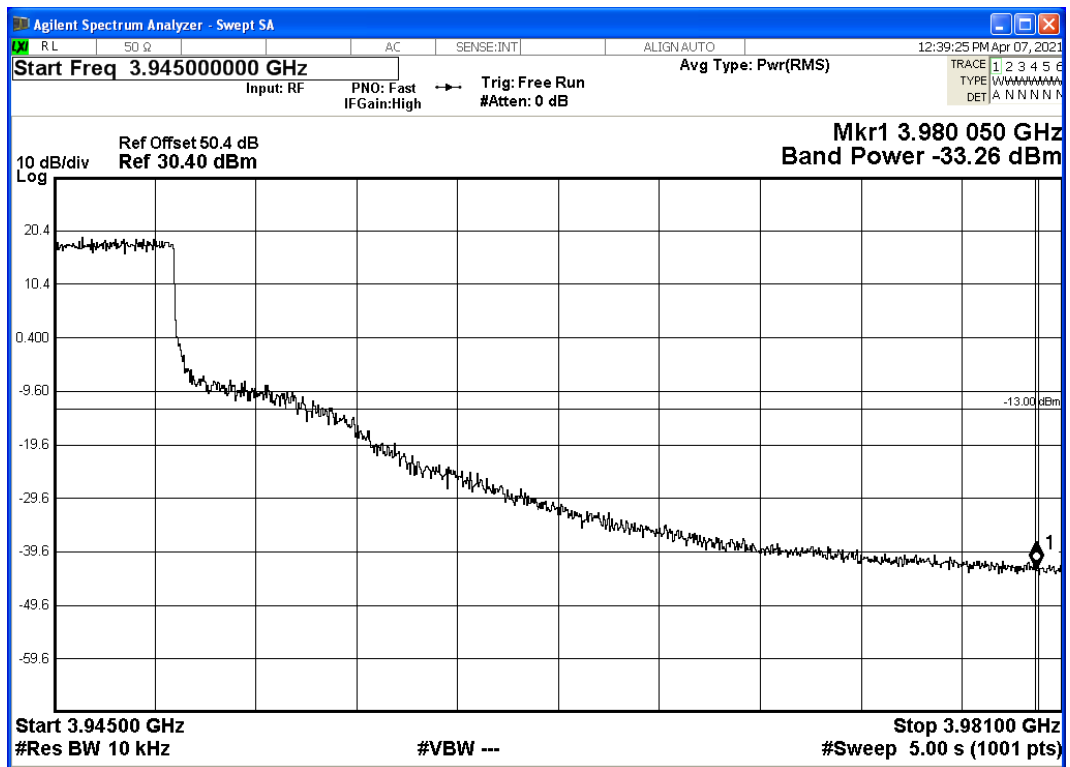

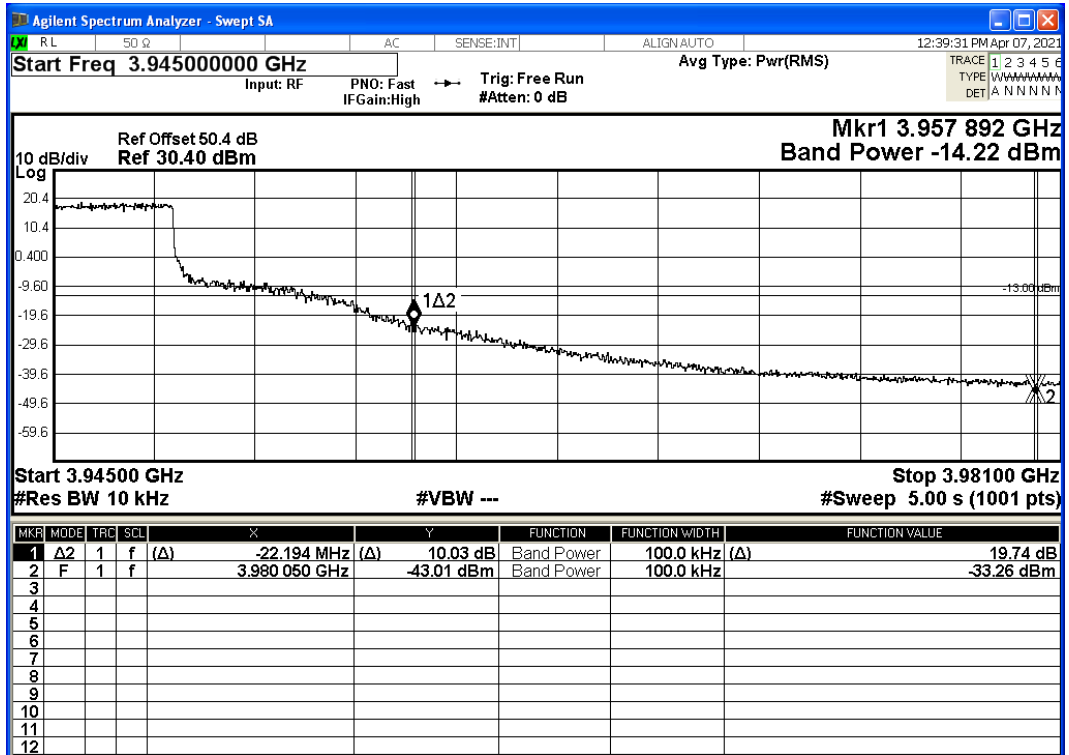



2.3.6.4 Top Channel: 3975 MHz

Maximum Target output Power: 30 dBm

Modulation	Carrier Bandwidth	Band Edge (MHz)
		Channel Position T:
5G: QPSK	5G: 10.0 MHz	3975

Antenna A: 5G Modulation QPSK - Carrier Bandwidth 10.0 MHz - Channel Position: 3975 MHz

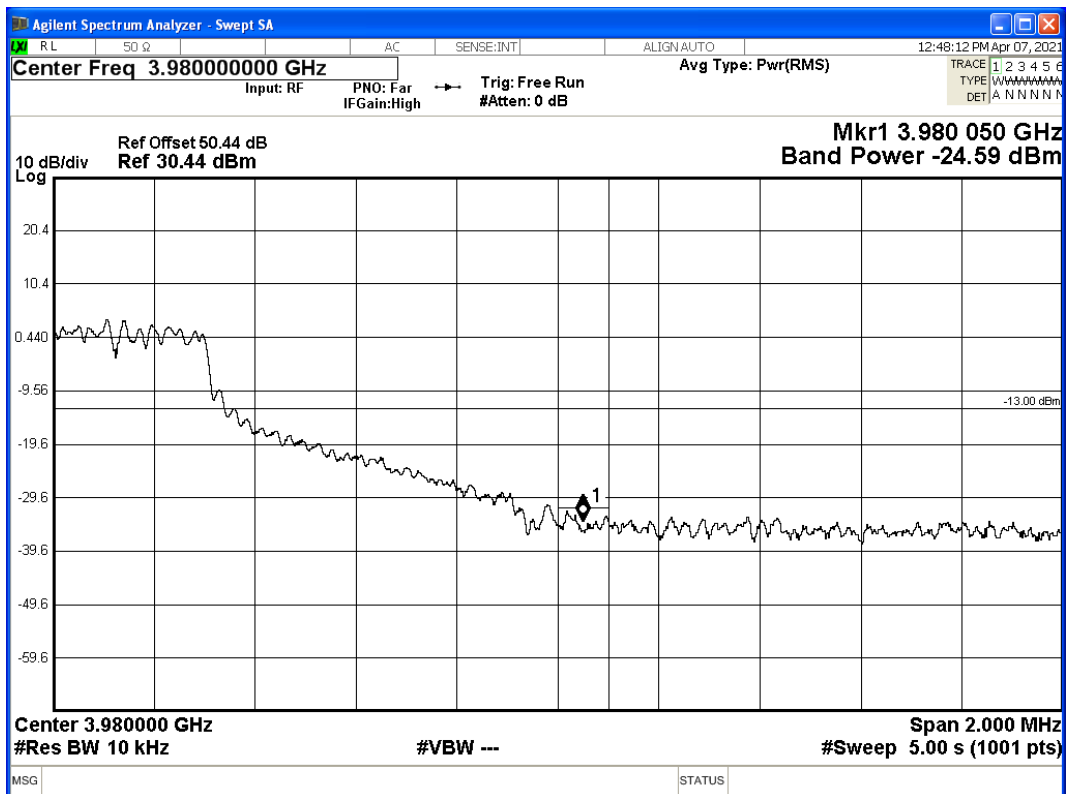

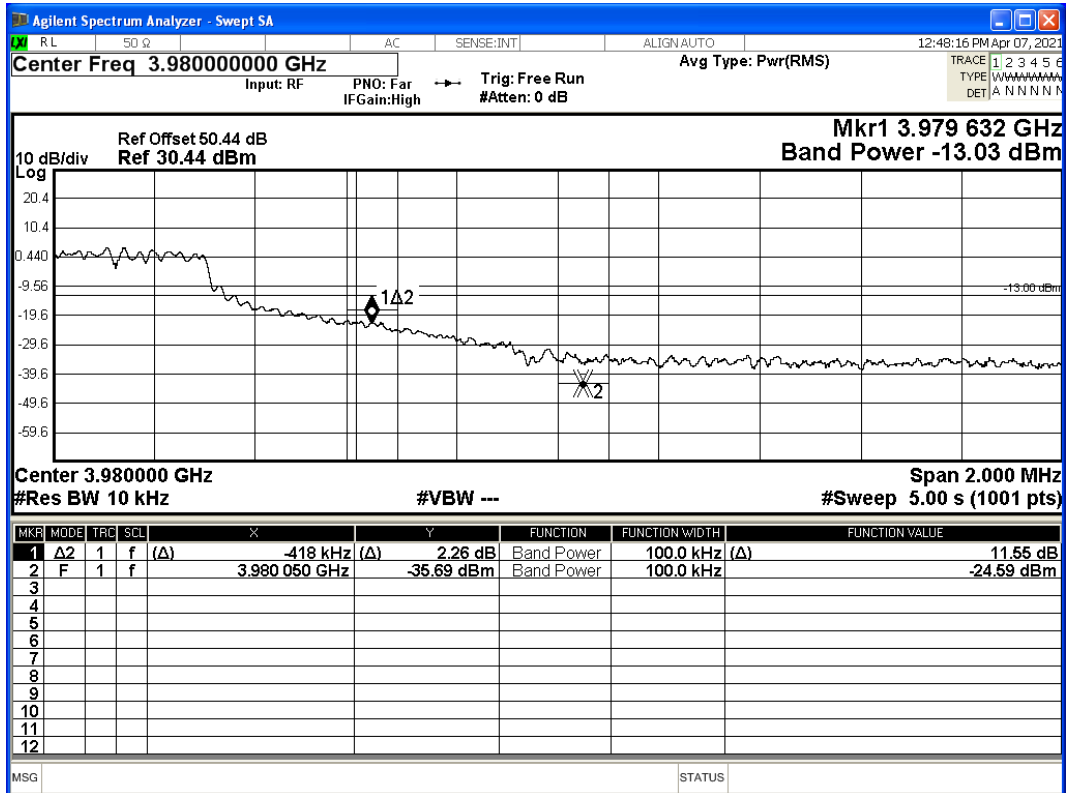

Limit	-13 dBm
-------	---------



2.4 TRANSCEIVER SPURIOUS EMISSIONS – CONDUCTED

2.4.1 Specification Reference

FCC CFR 47 Part 2, Clause 2.1051
FCC CFR 47 Part 27, Clause 27.53 (h)

2.4.2 Date of Test and Modification State

07 April 2021 - Modification State 0

2.4.3 Test Equipment Used

The major items of test equipment used for the above tests are identified in Section 3.1.

2.4.4 Environmental Conditions

Ambient Temperature	23.1°C
Relative Humidity	13.4%

2.4.5 Test Method

All measurements were made in accordance with FCC KDB 971168 D01.

All measurements were made in accordance with FCC KDB 971168 D01 Clause 6. The EUT was connected to a Spectrum Analyser via an attenuator and switching box. Prior to testing, a Network Analyser was used to calibrate the path loss between the EUT and the Spectrum Analyser. The worst-case path loss in the measured ranges was entered as a reference level offset. Over the measured ranges, the RBW was set to 1MHz with a VBW of 3MHz. All measurement results are specified as average with an RMS detector being used in conjunction with a trace setting of Max Hold. Measurements were performed in configurations of the EUT as reported below. Testing was performed on this port with a test limit of $43+10\log(P) = -13$ dBm.



2.4.6 Test Results

Range Frequency	Limit (dBm)	Result
9kHz to 3GHz	13	Pass
3GHz to 5G	13	Pass
5G to 26GHz	13	Pass
26GHz to 40GHz	13	Pass <Note 1>
Note 1. The device was scanned up to 40GHz with no emission (peak values less than 6Bd from the limit)		

Antenna A – 5G – Modulation QPSK - Carrier Bandwidth 10.0 MHz – Range 9kHz to 3GHz

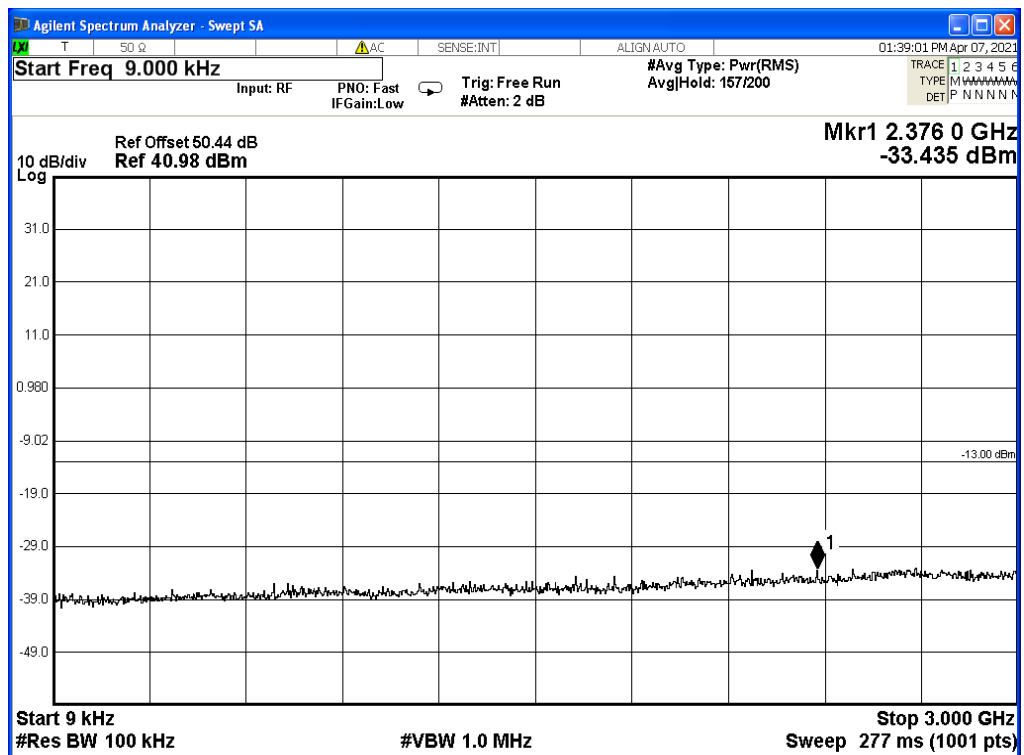

Note: A worst case factor of $10\log(100\text{ kHz} / 1\text{ MHz})$ or 10 dB is applied to the marker at which a reading of -26.46 dBm is obtained over 1 MHz.



Antenna A – 5 GHz Modulation QPSK - Carrier Bandwidth 10.0 MHz - Channel Position B: 3905 MHz: Range 3GHz to 5G

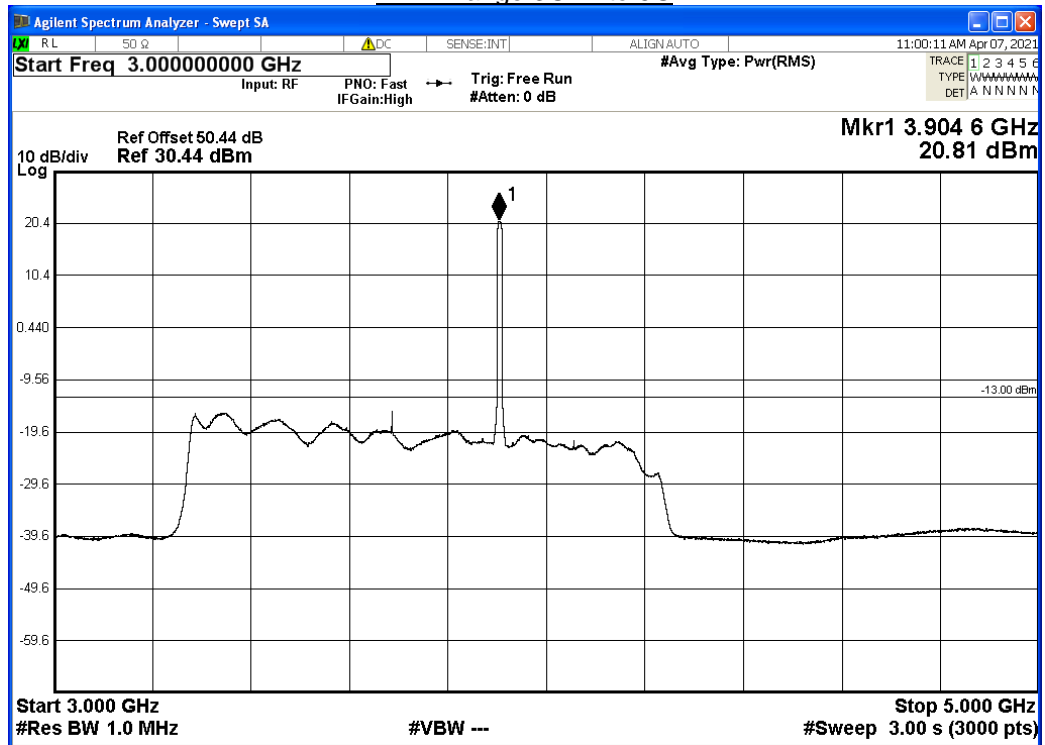

Antenna A – 5 GHz Modulation QPSK - Carrier Bandwidth 10.0 MHz - Channel Position B: 3925 MHz – Range 3GHz to 5G

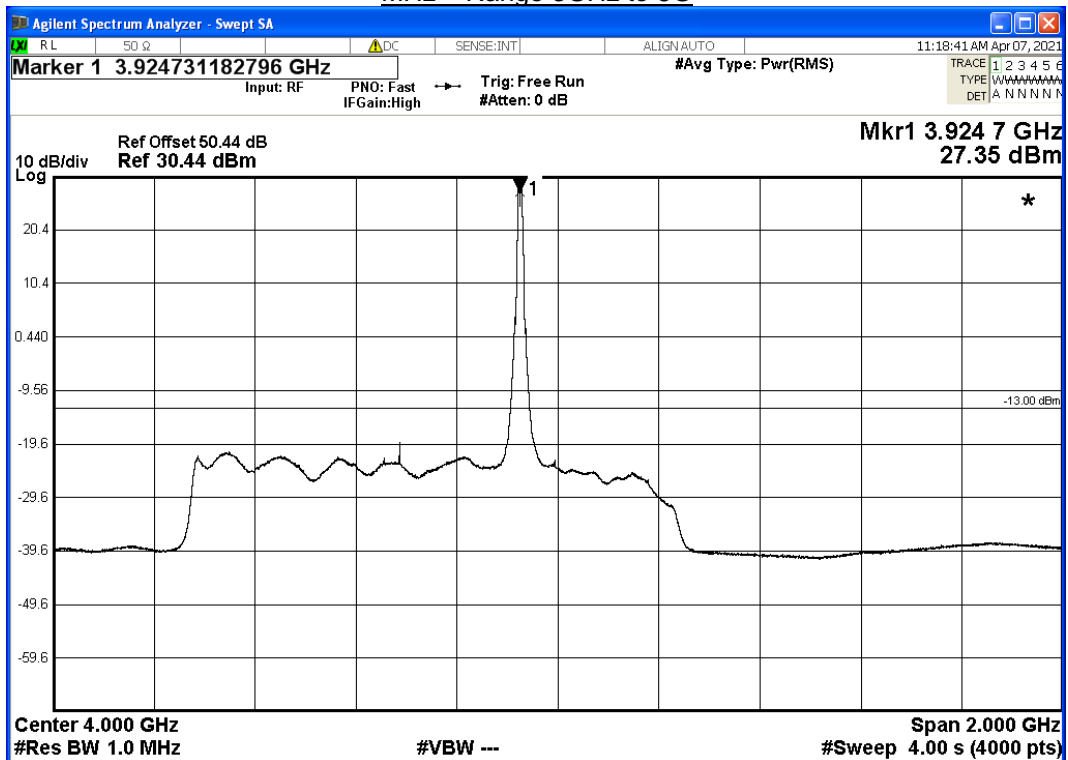



Antenna A – 5G, Modulation QPSK - Carrier Bandwidth 10.0 MHz - Channel Position B: 3930 MHz – Range 3GHz to 5G

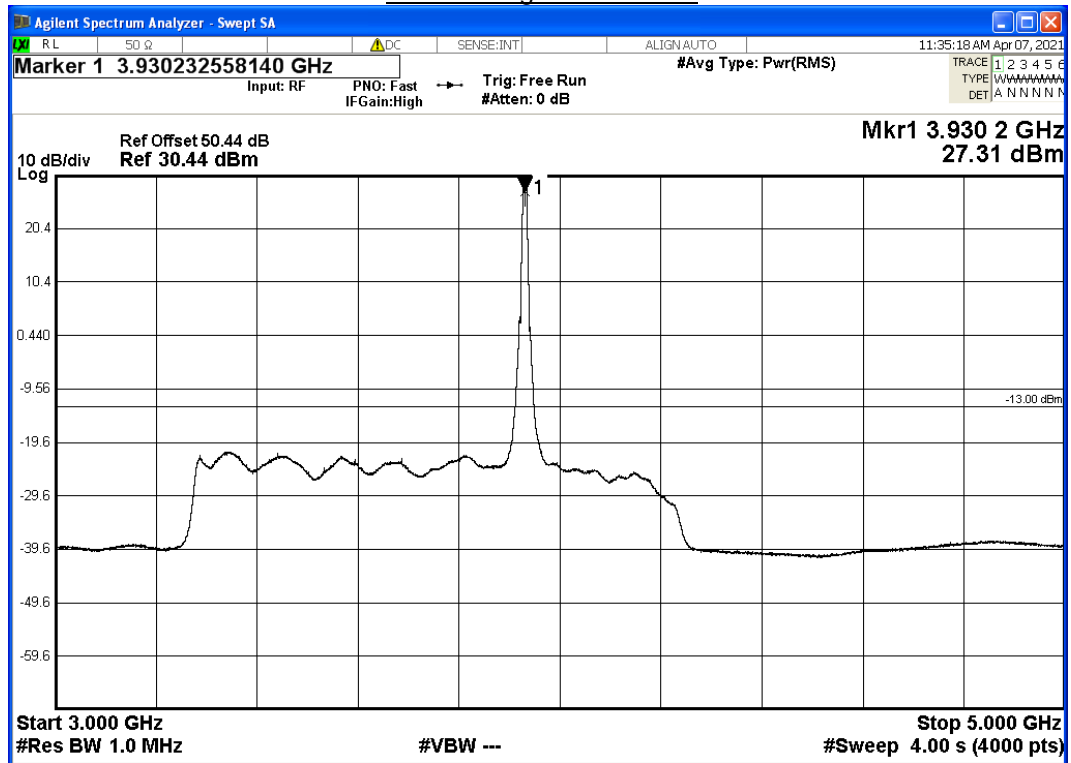

Antenna A, 5G Modulation QPSK - Carrier Bandwidth 10.0 MHz - Channel Position M: 3935 MHz – Range 3GHz to 5G

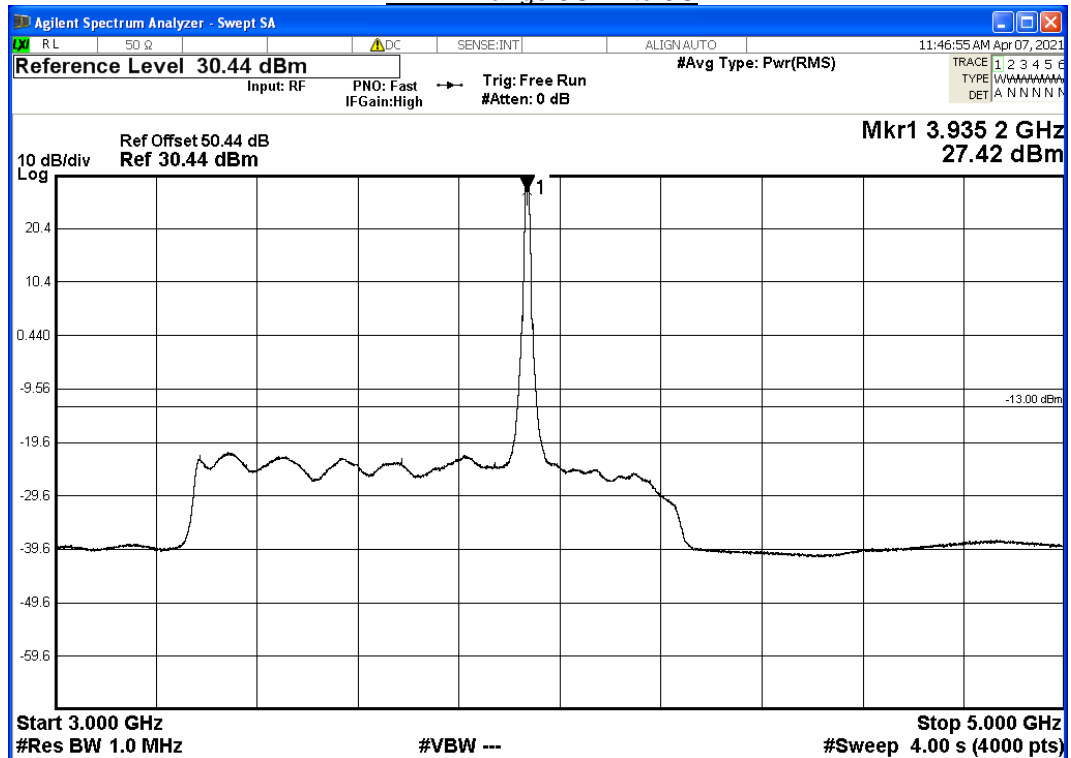

Antenna A, 5G Modulation QPSK - Carrier Bandwidth 10.0 MHz - Channel Position Top: 3940 MHz – Range 3GHz to 5G

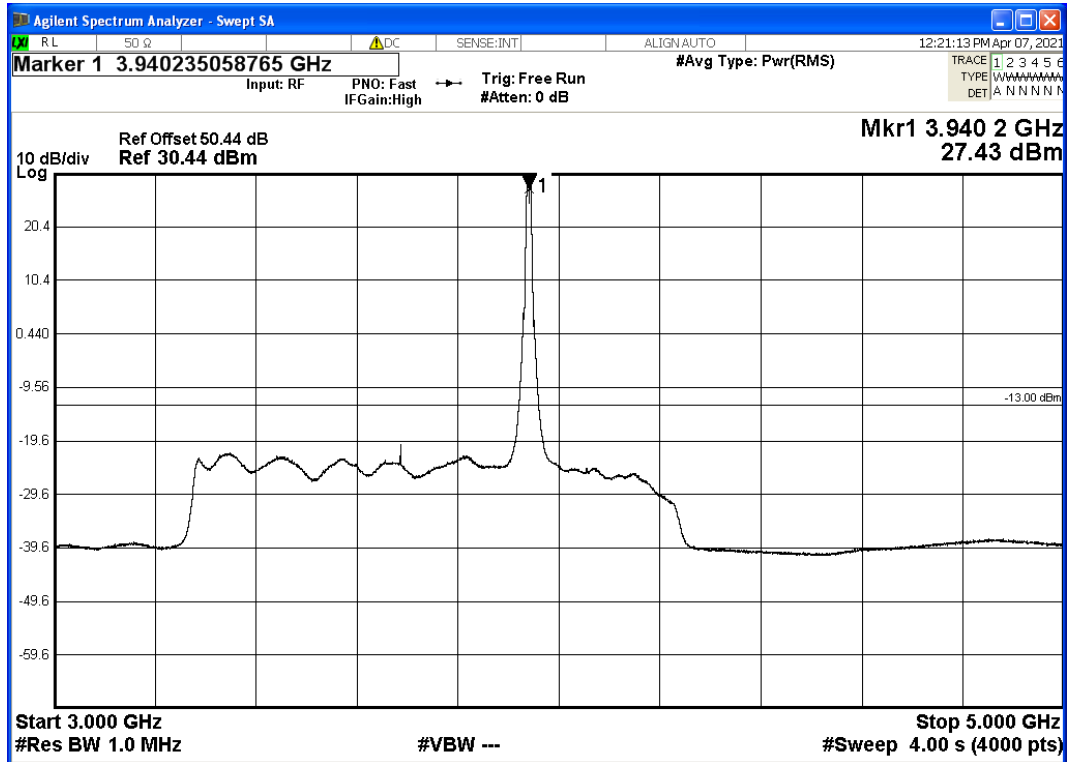

Antenna A, 5G Modulation QPSK - Carrier Bandwidth 10.0 MHz - Channel Position Top: 3945 MHz – Range 3GHz to 5G

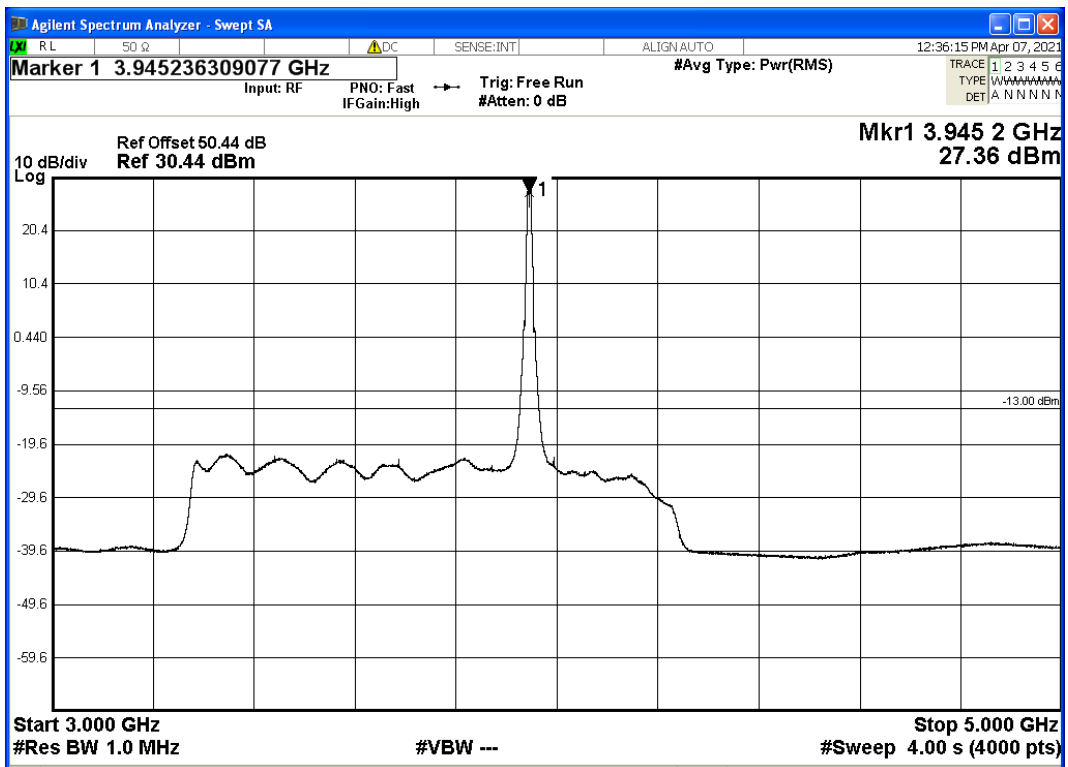

Antenna A, 5G Modulation QPSK - Carrier Bandwidth 10.0 MHz - Channel Position T: 3975 MHz – Range 3GHz to 5G

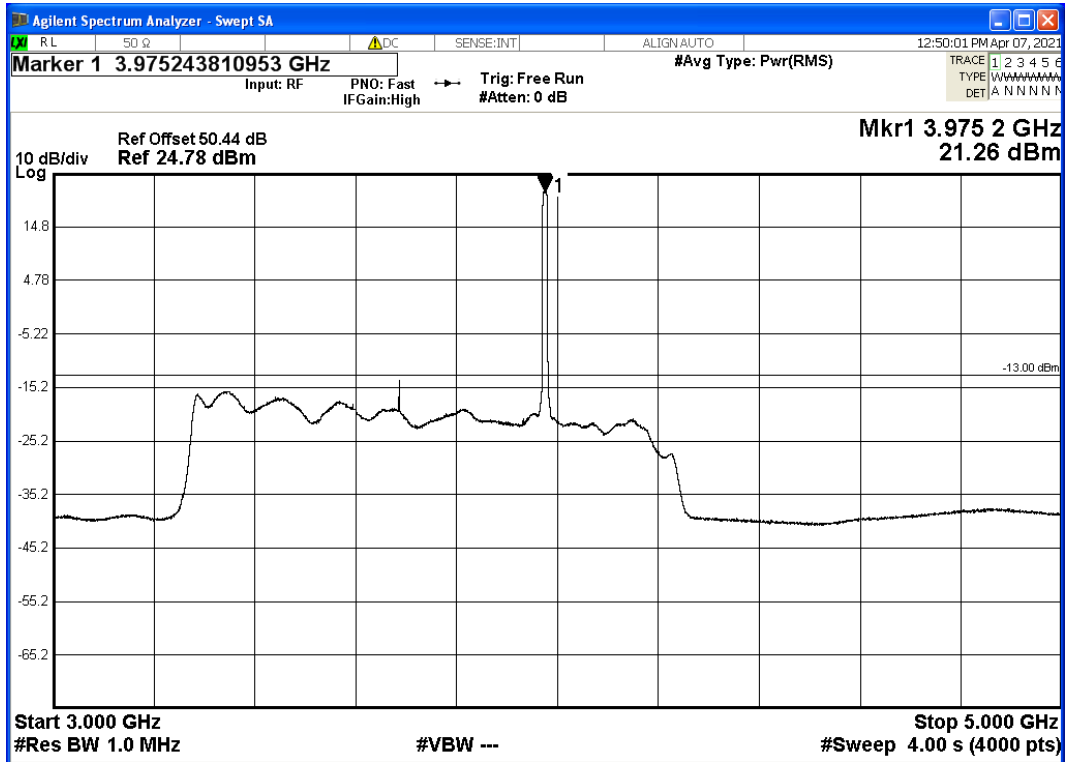



Antenna A, 5 GHz Modulation QPSK - Carrier Bandwidth 10.0 MHz - Range 5G to 26GHz

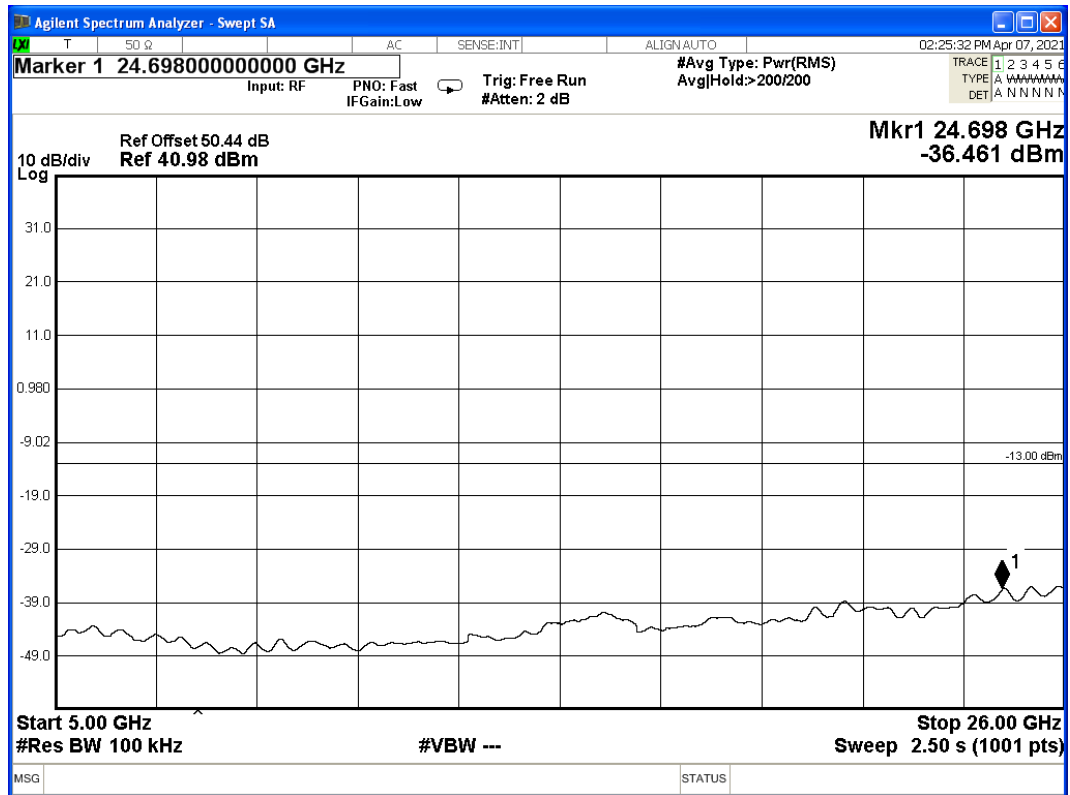

Note: A worst case factor of $10\log(100 \text{ kHz} / 1 \text{ MHz})$ or 10 dB is applied to the marker at which a reading of -26.46 dBm is obtained over 1 MHz.

Limit	-13dBm
-------	--------



2.5 FREQUENCY STABILITY

2.5.1 Specification Reference

FCC CFR 47 Part 2, Clause 2.1055
FCC CFR 47 Part 27, Clause 27.54

2.5.2 Date of Test and Modification State

05 April 2021 - Modification State 0

2.5.3 Test Equipment Used

The major items of test equipment used for the above tests are identified in Section 3.1.

2.5.4 Environmental Conditions

Ambient Temperature 26.7°C
Relative Humidity 32.2%

2.5.5 Test Method

All measurements were made in accordance with FCC KDB 971168 D01.

2.5.6 Test Results

Maximum Target Output Power 47 dBm

Temperature	Voltage (AC)	Frequency Error (Hz)	Limit ppm	Error/Freq ppm	Result <Note 1>
-30°C	115	-419.99	±1	-0.11	Pass
-20°C	115	-440.39	±1	-0.11	Pass
-10°C	115	-469.34	±1	-0.12	Pass
0°C	115	-541.05	±1	-0.14	Pass
+10°C	115	-575.55	±1	-0.15	Pass
+20°C	115	-686.33	±1	-0.17	Pass
+20°C	90	-512.91	±1	-0.13	Pass
+20°C	132	-510.48	±1	-0.13	Pass
+30°C	115	-655.38	±1	-0.17	Pass
+40°C	115	-518.95	±1	-0.13	Pass
+55°C	115	-545.13	±1	-0.14	Pass

Note 1. The frequency stability shall be sufficient to ensure that the fundamental emissions stay within the authorized bands of operation



2.6 FIELD STRENGTH OF SPURIOUS EMISSION– RADIATED

2.6.1 Specification Reference

FCC CFR 47 Part 27

2.6.2 Date of Test and Modification State

March 30th 2021 - Modification State 0

2.6.3 Test Equipment Used

The major items of test equipment used for the above tests are identified in Section 3.1.

2.6.4 Environmental Conditions

Ambient Temperature	23.1°C
Relative Humidity	13.4%

2.6.5 Test Method

All measurements were made in accordance with:

- 971168 D01 Power Meas License Digital Systems v03r01 Clause 5.6
- 971168 D01 Power Meas License Digital Systems v03r01 Clause 7

From Clause 5:6, the field strength of the EUT can be calculated by:

$$\text{EIRP} = P_{\text{meas}} + A_{\text{gain}} = 47\text{dBm} + 7\text{dBi} = 54\text{dBm} \text{ (or } 149.23 \text{ dB}\mu\text{V/m at } 3\text{m)}$$

Measurements were performed in configurations of the EUT as reported below. Testing was performed on this port with a test limit of FCC 15 Subpart B Class B of 40 dB μ V/m, which is more restricted than -13dBm or 84.38 dB μ V/m at 3m.



2.6.6 Test Results

A summary of the test result is depicted in the table below.

Range Frequency	Limit (dBm)	Result
9kHz to 150kHz	84.38	Pass <Note 1>
150kHz to 30MHz	84.38	Pass
30MHz to 1GHz	84.38	Pass
1GHz to 10GHz	84.38	Pass
10GHz to 18GHz	84.38	Pass
18GHz to 40GHz	84.38	Pass <Note 2>
Note 1. Radiated Spurious unintentional emissions was performed according to FCC 15 Subpart B, therefore extended down to 9 kHz following the limits provided in 15.209		
Note 2. The device was scanned up to 40Ghz with no emission (peak values less than 6Bd from the limit)		



Spurious Radiation Emission – 9kHz to 150kHz

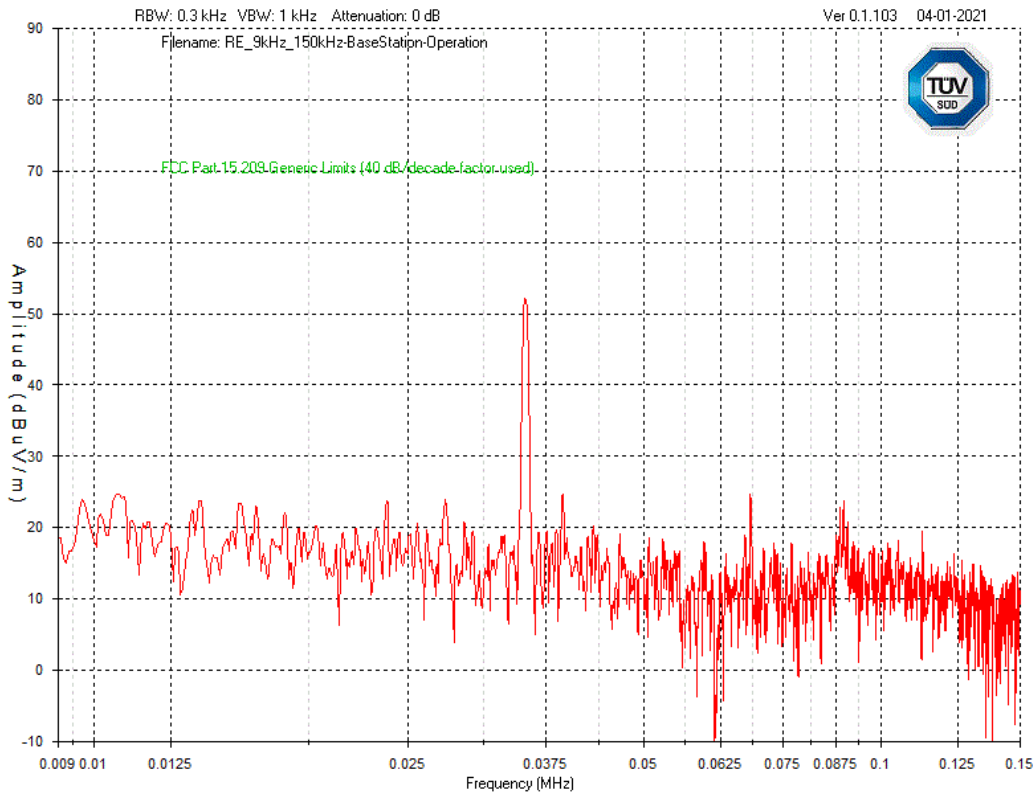

Note 1. The spurious emissions comply with the limit of 84.38 dBµV/m at 3m

Frequency (MHz)	Detector	Raw Reading	Atten 6dB Factor	Cable 28 - 7m LMR400 Factor	Loop - EM6871 30 Hz to 1M Factor	Level	FCC Part 15.209 Generic Limits (40 dB/decade factor used) Limit	FCC Part 15.209 Generic Limits (40 dB/decade factor used) Margin
0.0353	PEAK	40.5	6	0	5.7	52.2	116.7	64.5
0.0897	PEAK	13.9	6	0	3.8	23.7	108.6	84.9
0.0887	PEAK	13.1	6	0	3.8	22.9	108.6	85.7



Spurious Radiation Emission – 150kHz to 30MHz

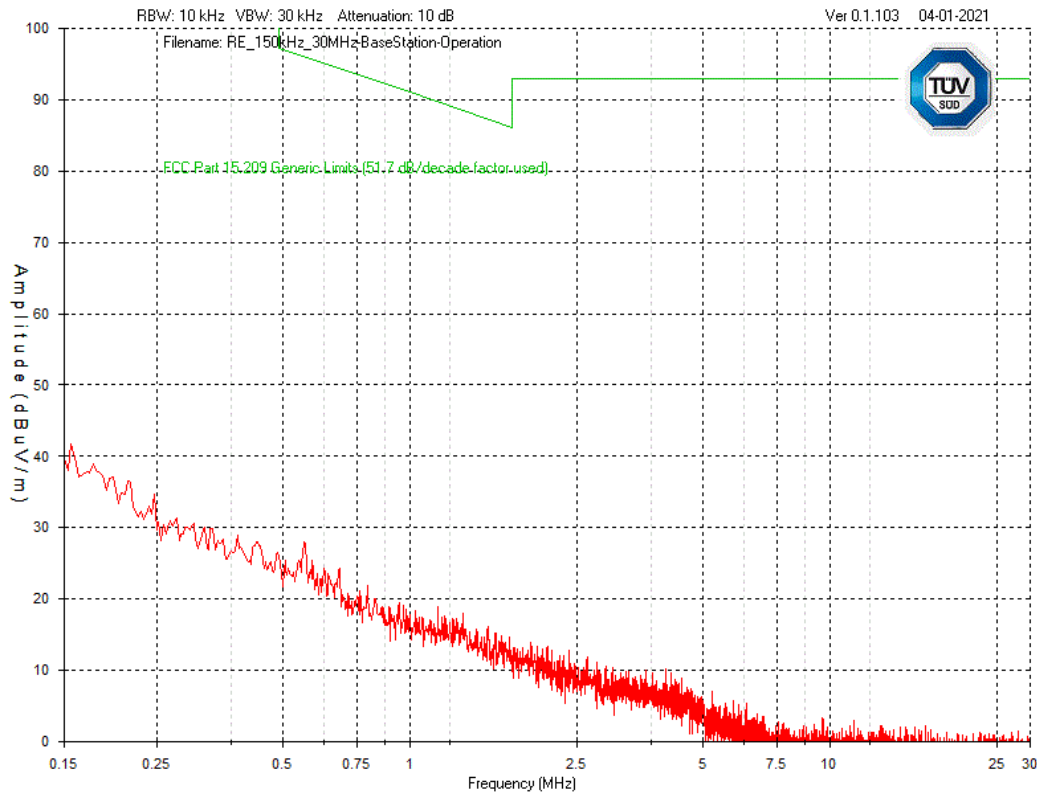

Note 1. The spurious emissions comply with the limit of 84.38 dB μ V/m at 3m

Frequency (MHz)	Detector	Raw Reading	Atten 6dB Factor	Cable 27 - 10m LMR400 Factor	Loop - EM6872 100k to 30M Factor	Level	FCC Part 15.209 Generic Limits (51.7 dB/decade factor used) Limit	FCC Part 15.209 Generic Limits (51.7 dB/decade factor used) Margin
0.5613	PEAK	21.9	6	0	0.2	28.1	96	67.9
2.3987	PEAK	16.9	6	0.1	-10.2	12.8	92.9	80.1
2.8033	PEAK	16.3	6	0.1	-11.3	11.1	92.9	81.8
4.0637	PEAK	17.2	6	0.1	-13.2	10.1	92.9	82.8



Spurious Radiation Emission –30MHz to 1GHz

Emi CC test RE 30-1000 MHz 3m FCC Class A-Operatinn Number :120 Execution date: 3/30/2021 10:41:14	
Limit	FCC Part 15 Subpart B
Class	Class: B
Test Plan Number	N/A
Configuration Information	Operating Mode
Results	Pass
Model	CBRRFE6600
Tested by	JM
Comments	Power: 120V/80Hz

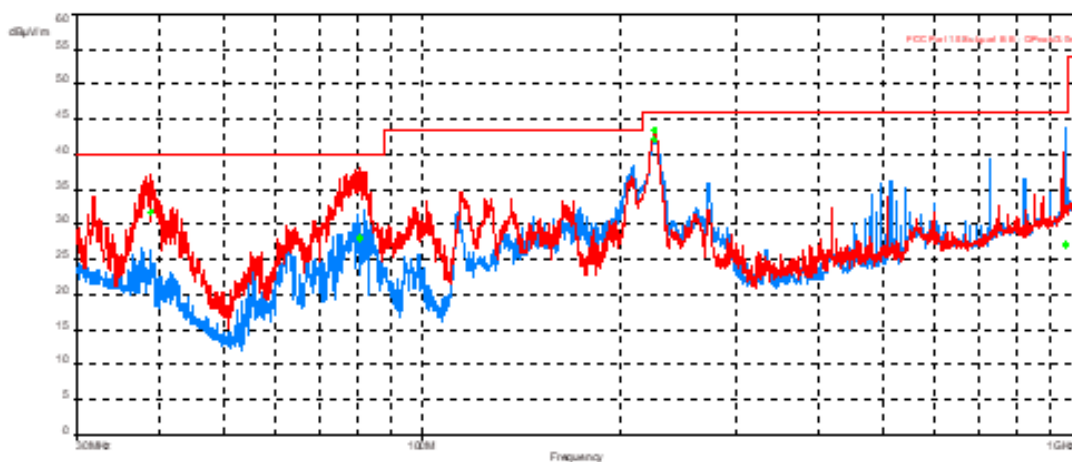

Red=Vertical, Blue=Horizontal

Suspects

Finals

QuasiPeak (5)								
Frequency (MHz)	SR	Level (dBuV/m)	Limit (dBuV/m)	Margin (dB)	Height (m) (dB)	Azimuth (°) (dB)	Polarization (dB)	Correction (dB)
38.84539069	1	31.82	40.00	-8.18	1.00	139.25	Vertical	-5.46
80.51219905	1	28.06	40.00	-11.94	3.81	11.75	Vertical	-11.85
225.5280033	1	43.43	46.02	-2.59	1.00	360.25	Vertical	-8.63
225.2377628	2	42.13	46.02	-3.89	1.11	247.25	Horizontal	-8.66
950.5497115	2	27.15	46.02	-18.87	1.14	328.50	Horizontal	8.50

Note 1. The spurious emissions comply with the limit of 84.38 dBuV/m at 3m



Spurious Radiation Emission –1GHz to 10GHz

Emi CC test:RE 1-10 GHz 3m FCC Class B- Operation Number :121 Execution date: 3/30/2021 1:05:19 PM	
Limit	FCC Part 15 Subpart B
Class	Class : B
Test Plan Number	N/A
Configuration Information	Operating Frequency-3780MHz
Results	Pass
Model	V850- Base Station
Tested by	JM
Comments	120V/60Hz

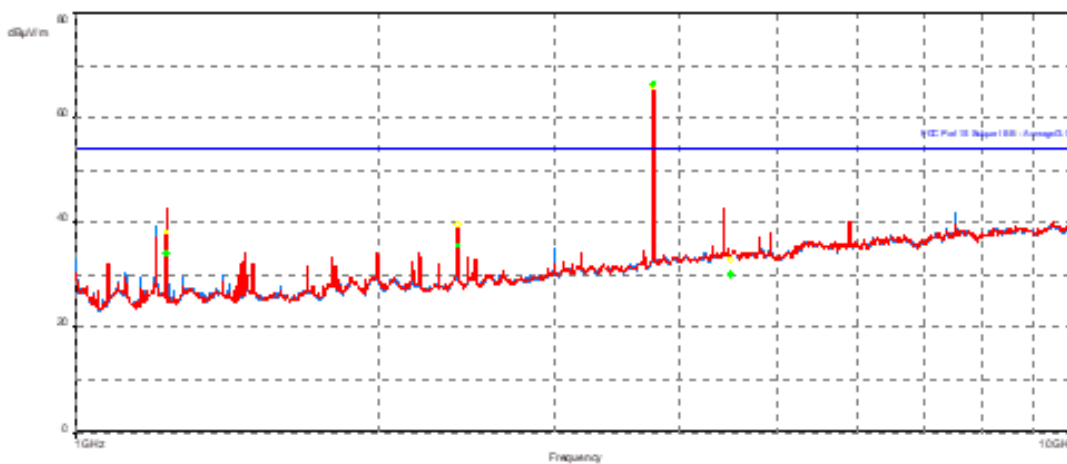

Red=Vertical, Blue=Horizontal

Finals

AVG (5)								
Frequency (MHz)	SR	Level (dBuV/m)	Limit (dBuV/m)	Margin (dB)	Height (m) (dB)	Azimuth (°) (dB)	Polarization (dB)	Correction (dB)
2399.997115	1	35.72	53.96	-18.24	3.18	277.00	Vertical	-9.58
3781.349359	1	66.49	53.96	12.53	2.42	341.75	Vertical	-5.00
4485.618269	1	30.11	53.96	-23.85	1.00	97.25	Vertical	-4.44
9993.21859	1	36.97	53.96	-16.99	1.00	358.00	Vertical	6.86
1228.800321	2	34.18	53.96	-19.78	2.88	334.00	Horizontal	-13.75

Note 1. Transmission at 3.7GHz of 66.49 dBuV/m (antenna port connected to 40dB attenuator)

Note 2. The spurious emissions comply with the limit of 84.38 dBuV/m at 3m



Spurious Radiation Emission –10GHz to 18GHz

Emi CC test-RE 10-18 GHz 3m FCC Class B- Operation Number :122 Execution date: 3/30/2021 2:27:22 PM	
Limit	FCC Part 15 Subpart B
Class	Class: B
Test Plan Number	N/A
Configuration Information	Operating Frequency-3760MHz
Results	Pass
Model	V850- Base Station
Tested by	JM
Comments	120V/60Hz

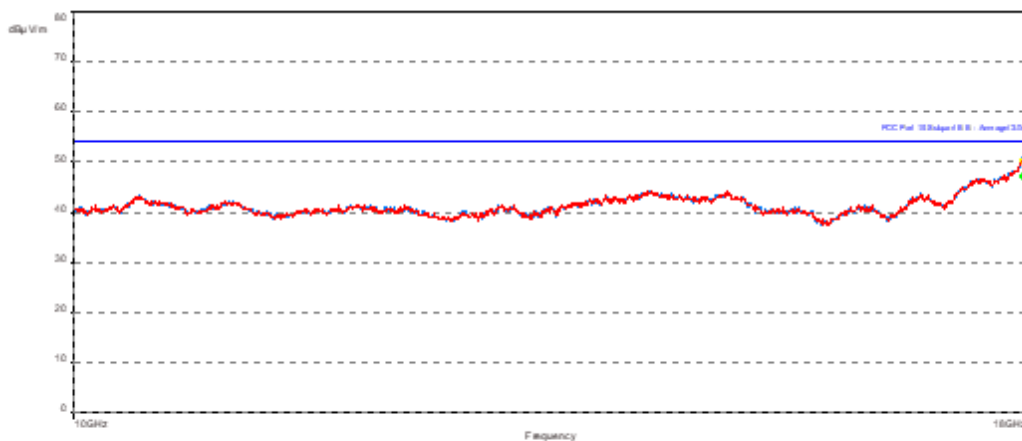

Red=Vertical, Blue=Horizontal

Finals

AVG (1)								
Frequency (MHz)	SR	Level (dBµV/m)	Limit (dBµV/m)	Margin (dB)	Height (m) (dB)	Azimuth (°) (dB)	Polarization (dB)	Correction (dB)
17896.025 64	1	47.25	53.96	-6.71	3.89	31.25	Vertical	19.92

Note 1. The spurious emissions comply with the limit of 84.38 dBµV/m at 3m



SECTION 3

TEST EQUIPMENT USED



3.1 TEST EQUIPMENT USED

List of absolute measurements and other principal items of test equipment.

Instrument	Manufacturer	Type No.	Serial No.	Calibration Period (months)	Calibration Due
PXA Signal Analyzer	Keysight	N9030A	MY53310519	24	24/04/2022
Coaxial Cable	Huber & Suhner	104PEA	SSG012041	2021-01-05	2022-01-05
Coaxial Cable	Huber & Suhner	106A	SSG013841	2021-01-05	2022-01-05
Pre-Amplifier	Hp	8447D	LAVE04346	2020-09-10	2021-09-10
Coaxial Cable	Huber & Suhner	106A	SSG012711	2021-01-05	2022-01-05
Bilog Antenna	Teseq	6111D	SSG013955	2019-12-03	2021-06-03
EMI Receiver	Rohde & Schwarz	ESU40	SSG013672	2020-10-29	2021-10-29
Coaxial Cable	Micro-Coax	UFA 210B-1-1500-504504	SSG012376	2021-01-06	2022-01-06
Coaxial Cable	Huber & Suhner	ST18/Nm/Nm/36	SSG012786	2021-01-05	2022-01-05
Pre-Amplifier	BNR	LNA	SSG012360	2020-11-16	2021-11-16
Double Ridged Horn Antenna	Emco	3115	SSG012508	2020-05-11	2021-05-11
Coaxial Cable	Huber & Suhner	101 PEA, Sucoflex	SSG012290	2020-11-04	2022-11-04
Horn Antenna (18 - 26.5 GHz)	Emco	3160-09	SSG012292	2019-08-26	2021-08-26
Horn Antenna (26.5 - 40 GHz)	Emco	3160-10	SSG012294	2019-08-26	2021-08-26
RF Filter: High Pass	Microwave Circuits inc.	H3G02G1	SSG012728	2021-01-06	2022-01-06
Attenuator	Narda	N/A	SSG013687	2021-01-06	2022-01-06
Thermometer	VWR	61161-364	192595396	24	25/10/2021
PSU	California Instruments	5001IX-CTS-411	1316A02581	N/A	O/P Mon
Attenuator (10dB)	Mini-Circuits	BW-K10-2W44+	-	N/A	O/P Mon
Emission software	Global EMC	0.1.95	58	NCR	NCR
Climate Chamber	Burnsco	RTC-37P-3-3	-07-07	N/A	O/P Mon
N/A: No applicable					
O/P Mon – Output monitored with Calibrated Equipment					



3.2 MEASUREMENT UNCERTAINTY

For a 95% confidence level, the measurement uncertainties for defined systems are:

Test Discipline	Frequency / Parameter	MU
Conducted Maximum Peak Output Power	30 MHz to 20 GHz Amplitude	± 0.1 dB
Conducted Emissions	30 MHz to 20 GHz Amplitude	± 2.3 dB
Frequency Stability	30 MHz to 2 GHz	± 5.0 Hz
Occupied Bandwidth	Up to 20 MHz Bandwidth	± 1.1 Hz
Band Edge	30 MHz to 20 GHz Amplitude	± 2.3 dB



SECTION 5

ACCREDITATION, DISCLAIMERS AND COPYRIGHT



4.1 ACCREDITATION, DISCLAIMERS AND COPYRIGHT



Testing Laboratory
Certificate #2955.19

This report relates only to the actual item/items tested.

This report does not imply product endorsement by any government, accreditation agency, or TÜV SÜD Canada Inc.

Opinions or interpretations expressed in this report, if any, are outside the scope of TÜV SÜD Canada Inc. accreditations. Any opinions expressed do not necessarily reflect the opinions of TÜV SÜD Canada Inc., unless otherwise stated.

This report relates only to the actual item/items tested.

© 2021 TÜV SÜD