

RF Report On



**Add value.
Inspire trust.**

FCC Testing of the Octasic Portable MIMO System in accordance with
FCC CFR 47 Part 2, and [FCC CFR 47 Part 22H](#)

COMMERCIAL-IN-CONFIDENCE

FCC: 2AQSOCBRSYS4450

PREPARED BY

Handwritten signature of Jose Martinez.

Jose Martinez

APPROVED BY

Handwritten signature of Scott Drysdale.

Scott Drysdale

DATED

Nov. 11, 21

11-Nov-21

Page 1 of 57

Report Issued:
11/11/2021

Report File #:
TR-7169009211M-
CBRSYS4450- UTMS_Band
5_FCC-Issue -04





Contents

| | | |
|--------------|---|-----------|
| 1 | SECTION 1: REPORT INFORMATION | 3 |
| 1.1 | Report Details | 4 |
| 1.2 | Brief Summary of Results | 5 |
| 1.3 | Product Information | 6 |
| 1.3.1 | Technical Description | 6 |
| 1.3.1.1 | The Transmission in the Band 5 | 6 |
| 1.3.2 | Configuration Description | 7 |
| 1.4 | Declaration of Build Status | 8 |
| 1.5 | General Test Setup | 10 |
| 1.6 | Test Conditions | 11 |
| 1.7 | Deviation From The Standard | 11 |
| 1.8 | Modification Record | 11 |
| 1.9 | TEST FACILITY | 11 |
| 2 | SECTION 2: TEST DETAILS | 12 |
| 2.1 | Maximum Peak Output Power and Peak to Average Ratio - Conducted | 13 |
| 2.1.1 | Specification Reference | 13 |
| 2.1.2 | Date of Test and Modification State | 13 |
| 2.1.3 | Test Equipment Used | 13 |
| 2.1.4 | Environmental Conditions | 13 |
| 2.1.6 | Test Results | 14 |
| 2.1.6.1 | Bottom Channel – 871.6MHz | 14 |
| 2.1.6.1.1 | Worst Case – Port 2B | 15 |
| 2.1.6.2 | Bottom Channel – 877.4MHz | 17 |
| 2.1.6.2.1 | Worst Case – Port 2B | 18 |
| 2.1.6.3 | Middle Channel: 882.6MHz | 20 |
| 2.1.6.3.1 | Worst Case – Port 2B | 21 |
| 2.1.6.4 | Top Channel: 887.4MHz | 23 |
| 2.1.6.4.1 | Worst Case – Port 1A | 24 |
| 2.2 | Occupied Bandwidth | 26 |
| 2.2.1 | Specification Reference | 26 |
| 2.2.2 | Date of Test and Modification State | 26 |
| 2.2.3 | Test Equipment Used | 26 |
| 2.2.4 | Environmental Conditions | 26 |
| 2.2.6 | Test Results | 26 |
| 2.2.6.1 | Bottom/Top Channel – 871.6 MHz | 27 |
| 2.2.6.1.1 | Worst Case – Port 2B | 27 |
| 2.2.6.1 | Bottom/Top Channel – 877.4 MHz | 28 |
| 2.2.6.1.1 | Worst Case – Port 2B | 28 |
| 2.2.6.2 | Middle Channel: 882.6 MHz | 29 |
| 2.2.6.2.1 | Worst Case – Port 1B | 29 |
| 2.2.6.1 | Top Channel – 887.4 MHz | 30 |
| 2.2.6.1.1 | Worst Case – Port 1A | 30 |
| 2.3 | Band Edge | 31 |
| 2.3.1 | Specification Reference | 31 |
| 2.3.2 | Date of Test and Modification State | 31 |
| 2.3.3 | Test Equipment Used | 31 |
| 2.3.4 | Environmental Conditions | 31 |
| 2.3.6 | Test Results | 32 |
| 2.3.6.1 | Bottom Channel – 871.6 MHz | 32 |
| 2.3.6.1.1 | Worst Case – Port 2B | 32 |
| 2.3.6.1 | Bottom/Top Channel: 877.4MHz | 34 |
| 2.3.6.1.1 | Worst Case – Port 2B | 34 |



| | | |
|-----------|--|-----------|
| 2.3.6.2 | Bottom/Top Channel: 882.6MHz | 36 |
| 2.3.6.2.1 | Worst Case – Port 2B | 36 |
| 2.3.6.3 | Bottom/Top Channel: 887.4MHz | 38 |
| 2.3.6.3.1 | Worst Case – Port 1A | 38 |
| 2.4 | Transceiver Spurious Emissions | 40 |
| 2.4.1 | Specification Reference..... | 40 |
| 2.4.2 | Date of Test and Modification State | 40 |
| 2.4.3 | Test Equipment Used | 40 |
| 2.4.4 | Environmental Conditions..... | 40 |
| 2.4.6 | Test Results | 41 |
| 2.4.6.1.1 | Worst Case – Port 1A | 41 |
| 2.5 | Frequency Stability | 45 |
| 2.5.1 | Specification Reference..... | 45 |
| 2.5.2 | Date of Test and Modification State | 45 |
| 2.5.3 | Test Equipment Used | 45 |
| 2.5.4 | Environmental Conditions..... | 45 |
| 2.5.6 | Test Results | 45 |
| 2.5.6.1.1 | Worst Case – Port 1A | 45 |
| 2.6 | Field Strength | 46 |
| 2.6.1 | Specification Reference..... | 46 |
| 2.6.2 | Date of Test and Modification State | 46 |
| 2.6.3 | Test Equipment Used | 46 |
| 2.6.4 | Environmental Conditions..... | 46 |
| 2.6.6 | Test Results | 47 |
| 3 | SECTION 3: TEST EQUIPMENT USED | 52 |
| 3.1 | Test Equipment Used | 53 |
| 3.2 | Measurement Uncertainty | 54 |
| 4 | ACCREDITATION, DISCLAIMERS AND COPYRIGHT..... | 55 |
| 4.1 | Accreditation, Disclaimers and Copyright..... | 56 |



SECTION 1: REPORT INFORMATION



1.1 REPORT DETAILS

| | |
|--------------------------------------|--|
| Manufacturer | Octasic inc. |
| Manufacturer Description | CBRSYS4450 |
| Address | 2901 Rachel St. East, Suite 30. Montreal, QC, H1W 4A4 |
| Product Name | Portable MIMO System |
| Product Number | CBRSYS4450 |
| Serial Number(s) | F-01150 |
| Hardware Version(s) | Version 1 |
| Software Version(s) | BSP CBRBTS-BSP-02.07.03.02-B454 |
| Test Specification/Issue/Date | FCC CFR 47 Part 2: August 16, 2021 FCC CFR 47 Part 22: September 1, 2021 |
| Max Antenna Gain | 5dBi |
| Start of Test | June 22, 2021 |
| Finish of Test | November 11, 2021 |
| Name of Test Personnel(s) | Jose Martinez |
| Related Document(s) | KDB 971168 D01 v02r02: April 2018 KDB 662911 D01 v02r01: October 2013 |
| Test report revision history | <p>2021-09-15. Issue 000. Initial release.</p> <p>2021-09-29. Issue 001. FCC Label updated</p> <p>2021-01-04. Issue 002. ISED Clause updated</p> <p>2021-10-19. Issue 03. Modifications:</p> <ul style="list-style-type: none"> • Removed RSS-132 • Section 2.1. Power table arranged properly • Section 2.3.5. Update RBW method section <p>2021-11-11. Issue 04. Modifications:</p> <ul style="list-style-type: none"> • Section 2.1, 2.2 and 2.3. Added measurements of new carriers. |



1.2 BRIEF SUMMARY OF RESULTS

A summary of results for each configuration, in accordance with FCC CFR 47 Part 2 and [FCC CFR 47 Part 22H](#) is shown below.

Table 1 –Test Summary

| Section | FCC CFR 47 Part 2 | FCC CFR 47 Part 22 | Test Description | Result |
|---------|-------------------|----------------------------------|--------------------------------|--------|
| 2.1 | §2.1046 | §22.913(a)(1)(i) | Maximum Peak Output Power | Pass |
| 2.1 | §2.1049 | § 22.917 | Occupied Bandwidth | Pass |
| 2.2 | §2.1051 | §22.917 (a) | Band Edge | Pass |
| 2.3 | §2.1051 | §22.357 | Transceiver Spurious Emissions | Pass |
| 2.4 | §2.1055 | §22.355 | Frequency Stability | Pass |
| 2.3 | - | §22.983 | Filed Strength Limit | Pass |



1.3 PRODUCT INFORMATION

1.3.1 Technical Description

The EUT, hereafter referred as the Equipment Under Test (EUT) is a MIMO Station unit CBRSYS4450 of Octasic Inc operating in the Block A (869MHz – 880MHz) and Block B (880MHz – 890MHz) and according to [22.905](#) for cellular service.

1.3.1.1 The Transmission in the Band 5

The channel configuration is as follows:

| Channels | Frequency (MHz) | Target Power (dBm) | Power Measured (dBm) |
|--|-----------------|--------------------|----------------------|
| Bottom/Top | 871.6 | 30 | 29.55 <Note 1> |
| Bottom/Top | 877.4 | 30 | 29.82 <Note 2> |
| Bottom/Top | 882.6 | 30 | 29.69 <Note 3> |
| Bottom/Top | 887.4 | 30 | 29.97 <Note 4> |
| Note 1. See Table 3 in Section 2.1.6.1 Note 2. See Table 4 in Section 2.1.6.2 Note 3. See Table 5 in Section 2.1.6.3. Note 4. See Table 5 in Section 2.1.6.4. | | | |

A full technical description can be found in the Manufacturer's documentation guide and datasheet CBRSYS4450-User_Guide.pdf and CBRSYS4450-Datasheet.pdf, respectively.



1.3.2 Configuration Description

The EUT supports single mode operation having four transmitting ports (see Figure 3)

TX test cases: Maximum Conducted Output Power, Spurious Emissions at Antenna Terminals (± 1 MHz) and Conducted Spurious Emissions, measurements were performed on the four RF Port. The test limits shown are representative of the worst case. All testing was performed with the EUT transmitting at maximum RF power unless as designated setting by client, otherwise stated.

The EUT was powered via a 120V/60Hz power AC/DC Adapter.

Channel Configurations:

Table 2 – Channel Configuration

| UTMS Band | No. Of Carriers | Modulation | Carrier Bandwidth | Carrier Frequency Configuration (MHz) | | |
|-----------|-----------------|------------|-------------------|---------------------------------------|-----------------------------|--------------------------|
| | | | | Bottom/ B_R FBW (MHz) | Middle/ M_{RFBW} (MHz) | Top/ T_{RFBW} (MHz) |
| 5 | 1 | QPSK | 5 MHz | 871.6 | 882.6 | 887.4 |



1.4 DECLARATION OF BUILD STATUS

| MAIN EUT | |
|--|---|
| MANUFACTURING DESCRIPTION | CBRSYS4450 |
| MANUFACTURER | Octasic inc. |
| TYPE | Portable Transportable Amplification Unit (TAU) |
| PART NUMBER(S) | CBRSYS4450 |
| SERIAL NUMBER(S) | F-01150 |
| HARDWARE VERSION(S) | Version 1 |
| SOFTWARE VERSIONS(S) | CBRBTS-BSP-02.07 |
| TRANSMITTER OPERATING RANGE (Band 5) | 871.6MHz – 887.4MHz |
| RECEIVER OPERATING RANGE(MHz) | 663 to 2690 |
| EMISSION DESIGNATOR(S): (i.e. G1D, GXW) | 194M |
| Country of Origin | Bangalore, India |
| MODULATION TYPES: (i.e. GMSK, QPSK) | QPSK |
| HIGHEST INTERNALLY GENERATED FREQUENCY | 2.7GHz |
| OUTPUT POWER (W or dBm) | 30dBm |
| FCC ID: | 2AQSO CBRSYS4450 |
| TECHNICAL DESCRIPTION (a brief description of the intended use and operation) | The CBRSYS4450 is a base station solution build for the particular needs of application like search and Rescue (SRR), Network in Box (NiB) and Disaster Recovery. It integrates four transceiver cellular base station (BTS) with all necessary RF, GPS and Wi-Fi antennas. The control is through an easy-to-use Android app on a smartphone or table for convenient on-the-go operation |

Equipment Under Test (EUT)



Figure 3. Top view of CBRSYS4450

1.5 GENERAL TEST SETUP

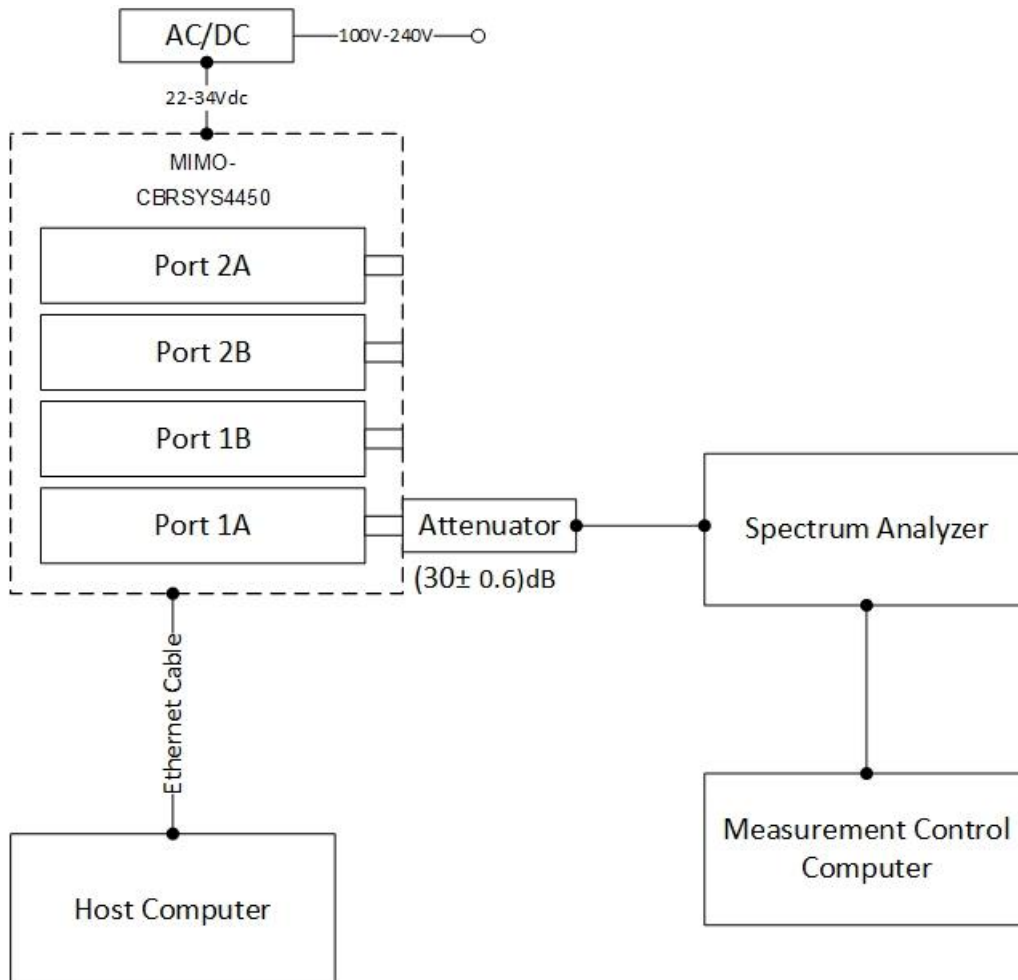

Figure 2. Block Diagram of Conducted Measurement Setup.



1.6 TEST CONDITIONS

For all tests the EUT was set up in accordance with the relevant test standard and to represent typical operating conditions. Tests were applied with the EUT situated as described in the Test Method for each Test.

The EUT was powered using the AC/DC adapter.

1.7 DEVIATION FROM THE STANDARD

No deviations from the applicable test standards or test plan were made during testing.

1.8 MODIFICATION RECORD

No modifications were made to the EUT during testing.

1.9 TEST FACILITY

FCC Measurement Facility Registration Number: CA4810

Under our group A2LA Accreditation, TÜV SÜD conducted the following tests at Kanata, Test Laboratory.

| Test Name | Name of Test Specialist(s) |
|---|----------------------------|
| Maximum Peak Output Power and Peak to Average Ratio - Conducted | Jose Martinez |
| Occupied Bandwidth | Jose Martinez |
| Band Edge | Jose Martinez |
| Transmitter Spurious Emissions | Jose Martinez |
| Frequency Stability | Jose Martinez |
| Field Strength of Spurious Emissions - Radiated | Jose Martinez |



SECTION 2: TEST DETAILS



2.1 MAXIMUM PEAK OUTPUT POWER AND PEAK TO AVERAGE RATIO - CONDUCTED

2.1.1 Specification Reference

FCC CFR 47 Part 2, Clause 2.1046
FCC CFR 47 Part 22H, [§22.913\(a\)\(1\)\(i\)](#)

2.1.2 Date of Test and Modification State

11 November 2021 -Modification State 0

2.1.3 Test Equipment Used

The major items of test equipment used for the above tests are identified in Section 3.1.

2.1.4 Environmental Conditions

| | |
|---------------------|--------|
| Ambient Temperature | 25.1°C |
| Relative Humidity | 20.4% |

2.1.5 Test Method

All measurements were made in accordance with FCC KDB 971168 D01, clause 5.2.1 and summed in accordance with FCC KDB 662911 D01. The attenuation value used throughout this report is 30dB ± 0.6dB.

Measurements were performed with a Spectrum Analyser using the Band Power measurement function. The detector was set to RMS with an RBW of at least 1 % of the carrier bandwidth and a VBW of at least 3 times the RBW. The integration bandwidth was configured to be wider than the total bandwidth of the carrier or combinations of carriers, (multi-carrier). Using a sweep time of auto, measurements were performed over 200 samples, with the average measurement recorded.

Due to Average measurements being recorded, an additional Peak to Average power ratio (PAPR) measurement was made. This was achieved using the CCDF function of the Spectrum Analyser with the RBW being set to a value wider than the largest signal being measured – in this case – 20MHz.

The EUT was configured to transmit on maximum power on the configurations defined in the tables below.

The peak to average ratio measurement was performed at the conducted ports of the EUT. The spectrum analyzer's Complementary Cumulative Distribution Function (CCDF) was used, and 0.1% probability value recorded.

The RMS Power and Peak to Average Ratio were measured and recorded with the results being compared with the limits.

Measurements presented are the worst-case of measurements conducted in the four ports: TX1A, TX1B, Tx2A and Tx2B, respectively.



2.1.6 Test Results

2.1.6.1 Bottom Channel – 871.6MHz

Maximum Target Output Power: 30 dBm

Table 3 – Max Peak Output Power – Bottom Channel

| Antenna | Output Power/PAPR | | | | | Result <Note 4> |
|--|-------------------|-------------------------|---------|-----------------|-------------------|--------------------|
| | PAPR | Conducted Average Power | | ERP <Note 2> | Limit <Note 3> | |
| | (@ 0.1%) | (dBm) | (mW) | (dBm) | (W) | |
| TX1A | 6.22 | 29.43 | 877.00 | 26.54 | 500 | Pass |
| TX1B | 6.24 | 29.5 | 891.25 | 26.78 | | |
| TX2A | 6.08 | 29.47 | 885.12 | 26.68 | | |
| TX2B | 6.16 | 29.55 <Note 1> | 901.57 | 26.62 | | |
| Total | | 35.51 | 3554.94 | - | | |
| Note 1. See worst-case TX1B in Graph 1 Note 2. ERP =EIRP -2.15 dB as per 412172 D01 Note 3 As per §22.913(a)(1)(i) | | | | | | |



2.1.6.1.1 Worst Case – Port 2B

Carrier Power Modulation QPSK - Carrier Bandwidth 5.0 MHz – Channel Position: 871.6 MHz

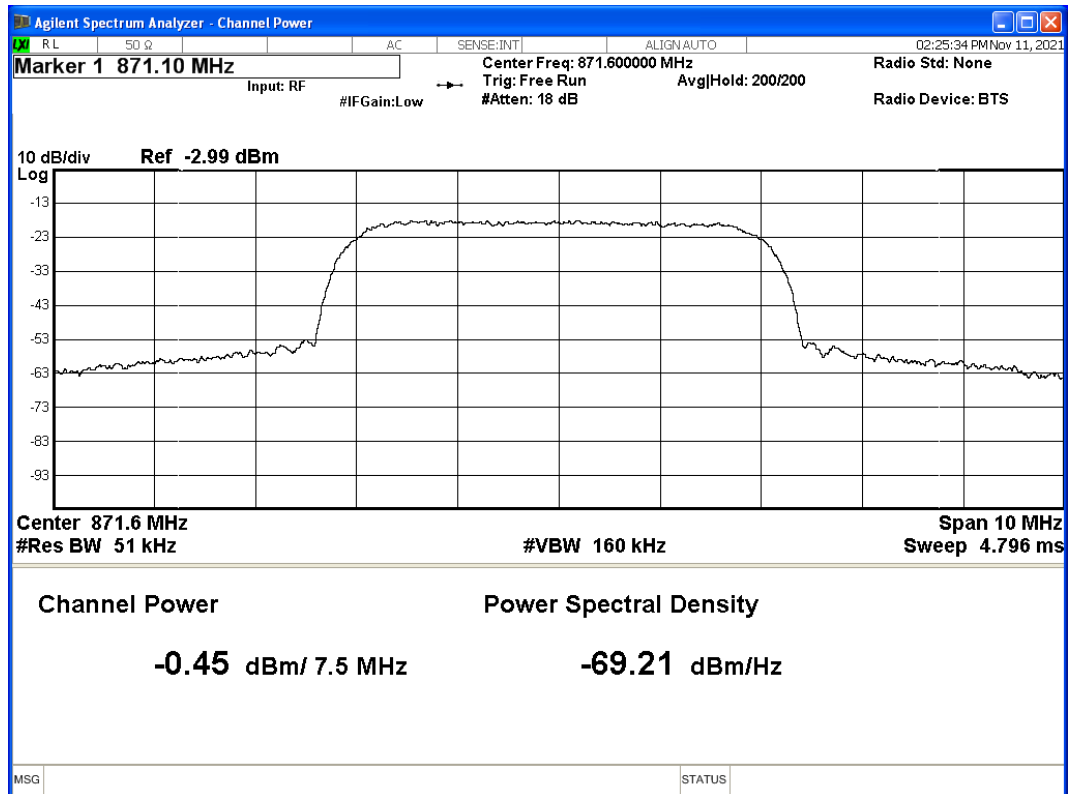

Graph 1: Output Power – Port 2B – Bottom Channel

Calculation: $30\text{dB} - 0.45\text{ dBm} = 29.55\text{ dBm}$.



PAPR - Carrier Bandwidth 5.0 MHz – Channel Position: 871.6 MHz

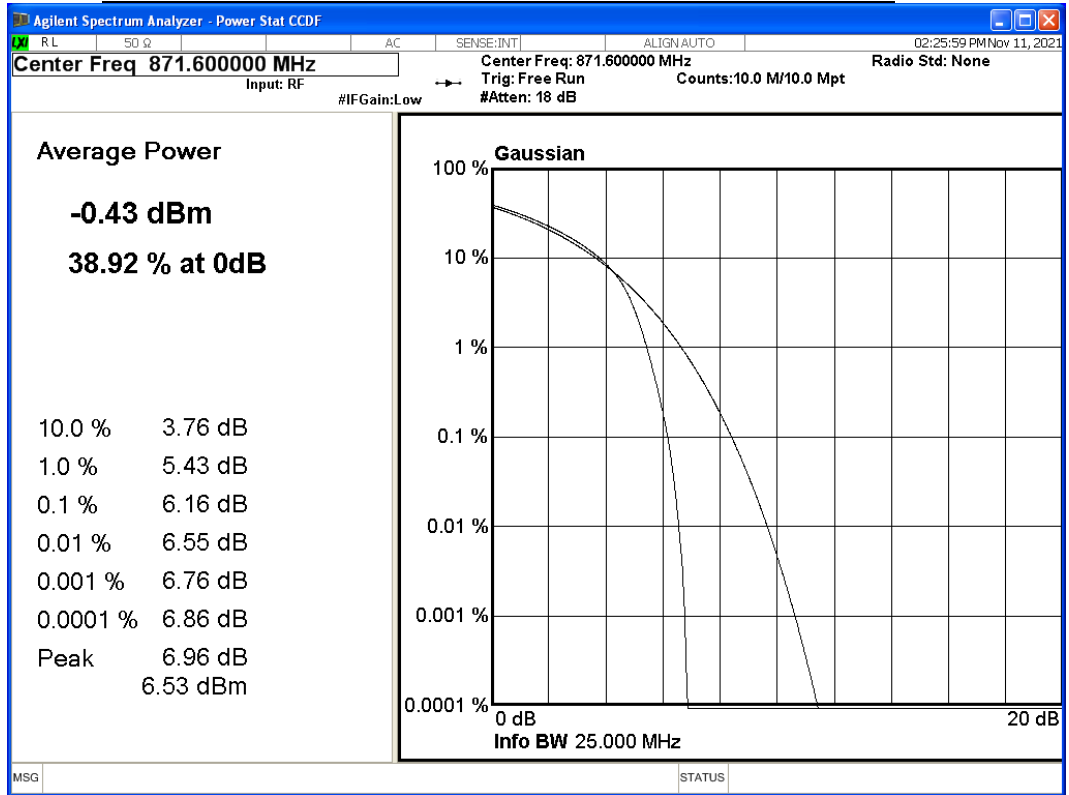



2.1.6.2 Bottom Channel – 877.4MHz

Maximum Target Output Power: 30 dBm

Table 4 – Max Peak Output Power – Bottom Channel

| Antenna | Output Power/PAPR | | | | | Result |
|---------|-------------------|-------------------------|---------|-----------------|-------------------|--------|
| | PAPR | Conducted Average Power | | ERP <Note 2> | Limit <Note 3> | |
| | (@ 0.1%) | (dBm) | (mW) | (dBm) | (W) | |
| TX1A | 6.20 | 29.53 | 897.43 | 26.85 | 500 | Pass |
| TX1B | 6.12 | 29.79 | 952.80 | 27.24 | | |
| TX2A | 6.14 | 29.45 | 881.05 | 26.63 | | |
| TX2B | 6.03 | 29.82 <Note 1> | 959.40 | 27.17 | | |
| Total | | 35.67 | 3690.67 | - | | |

Note 1. See worst-case TX1B in Graph 1
 Note 2. ERP =EIRP -2.15 dB as per [412172 D01](#)
 Note 3 As per [§22.913\(a\)\(1\)\(i\)](#)



2.1.6.2.1 Worst Case – Port 2B

Carrier Power Modulation QPSK - Carrier Bandwidth 5.0 MHz – Channel Position: 877.4 MHz

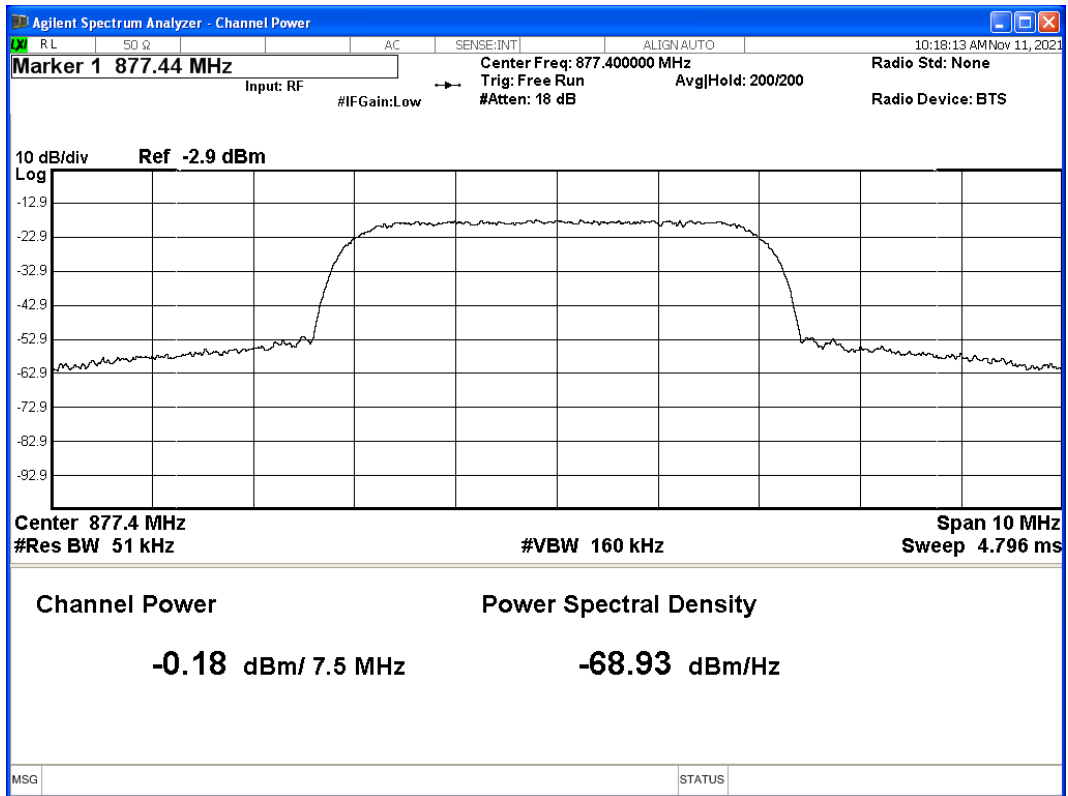

Graph 2: Output Power – Port 2B – Bottom Channel

Calculation: $30\text{dB} - 0.18\text{dBm} = 29.82\text{ dBm}$.



PAPR - Carrier Bandwidth 5.0 MHz – Channel Position: 877.4 MHz

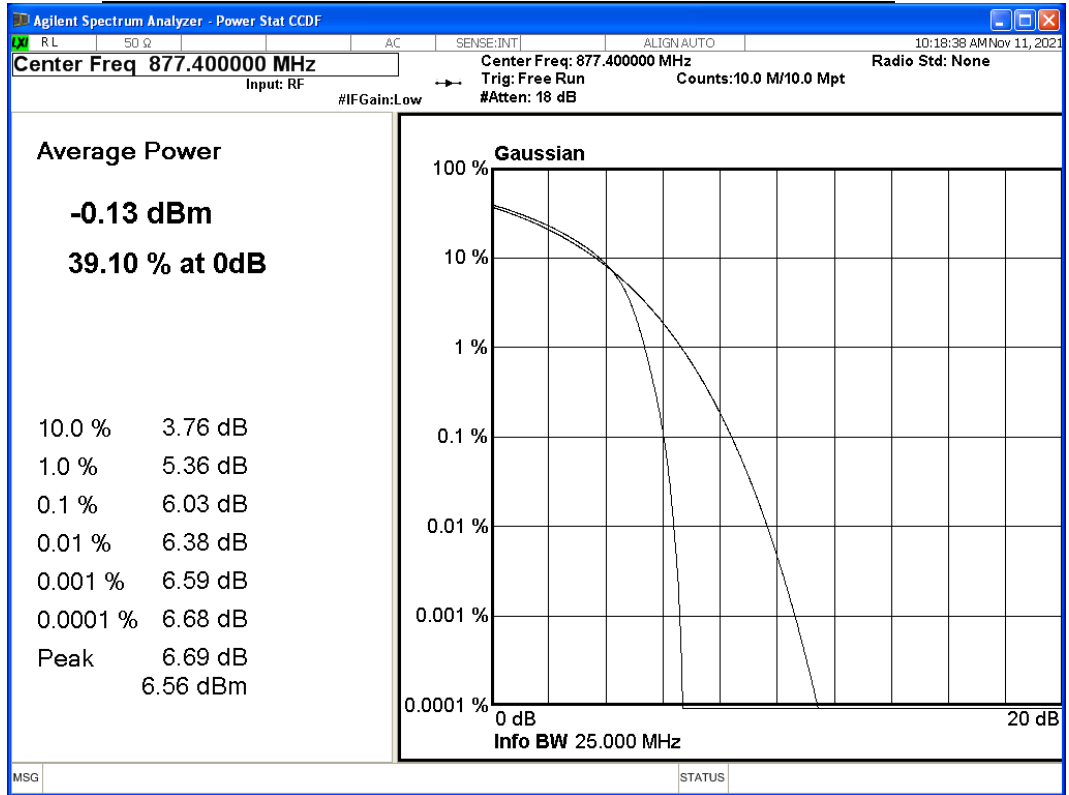



2.1.6.3 Middle Channel: 882.6MHz

Maximum Target Output Power: 30 dBm

Table 5 – Max Peak Output Power – Middle Channel

| Antenna | Output Power/PAPR | | | | | Result <Note 4> |
|---------|-------------------|-------------------------|---------|-----------------|-------------------|--------------------|
| | PAPR | Conducted Average Power | | ERP <Note 2> | Limit <Note 3> | |
| | (@ 0.1%) | (dBm) | (mW) | (dBm) | (W) | |
| TX1A | 6.16 | 29.66 | 924.70 | 34.66 | 500 | Pass |
| TX1B | 6.16 | 29.67 | 926.83 | 34.67 | | |
| TX2A | 6.04 | 29.56 | 903.65 | 34.56 | | |
| TX2B | 6.06 | 29.69 <Note 1> | 931.11 | 34.69 | | |
| Total | | 35.67 | 3686.29 | - | | |

Note 1. See worst-case TX1B in Graph 2
 Note 2. ERP =EIRP -2.15 dB as per [412172 D01](#)
 Note 3 As per [§22.913\(a\)\(1\)\(i\)](#)



2.1.6.3.1 Worst Case – Port 2B

Carrier Power - Modulation QPSK - Carrier Bandwidth 5.0 MHz – Channel Position:
882.6MHz

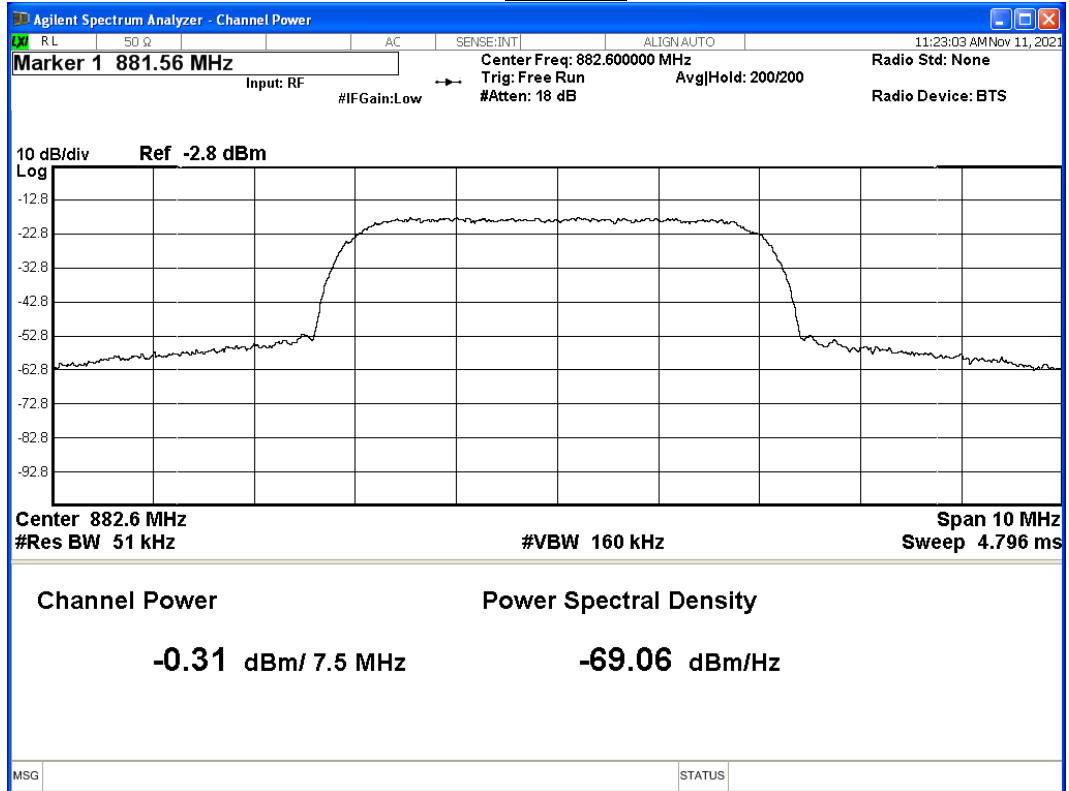

Graph 3: Output Power – Port 2B – Middle Channel

Calculation: $30.0\text{dB} - 0.31\text{ dBm} = 29.69\text{ dBm}$.



PAPR - Carrier Bandwidth 5.0 MHz – Channel Position: 882.6MHz

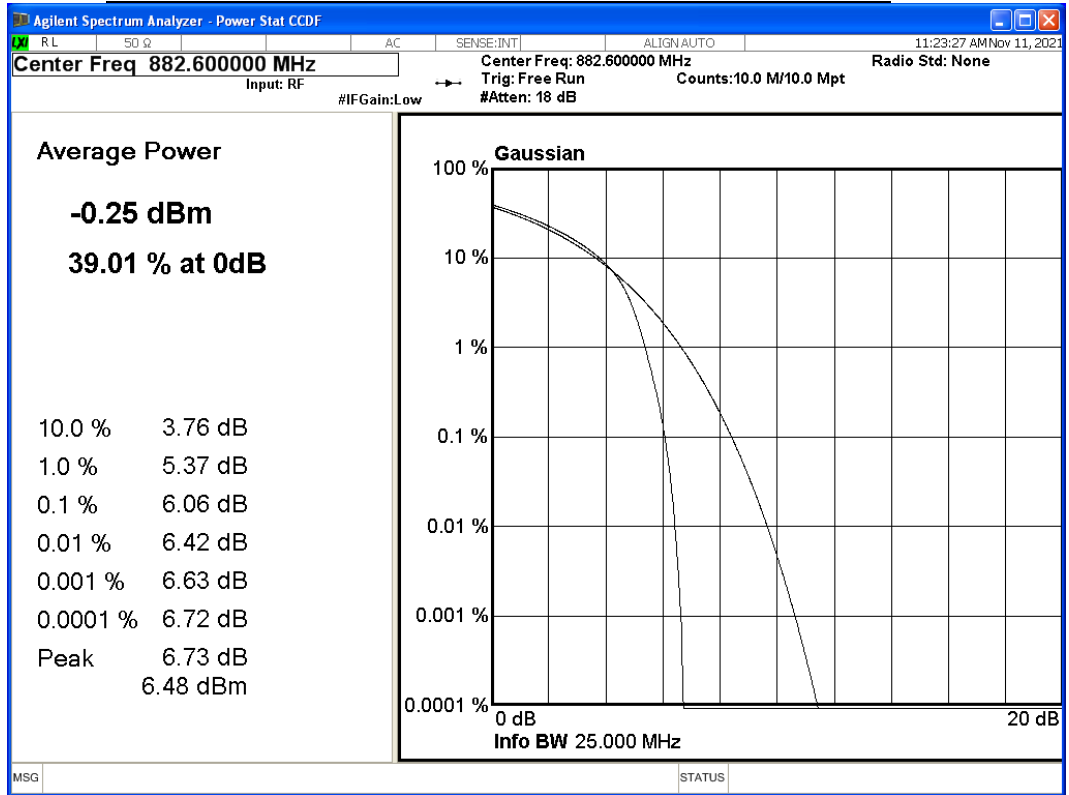



2.1.6.4 Top Channel: 887.4MHz

Maximum Target Output Power: 30 dBm

Table 6 – Max Peak Output Power – Top Channel

| Antenna | Output Power/PAPR | | | | | Result <Note 4> |
|---------|-------------------|-------------------------|---------|-----------------|-------------------|--------------------|
| | PAPR | Conducted Average Power | | ERP <Note 2> | Limit <Note 3> | |
| | (@ 0.1%) | (dBm) | (mW) | (dBm) | (W) | |
| TX1A | 6.01 | 29.97 <Note 1> | 993.12 | 34.97 | 500 | Pass |
| TX1B | 6.21 | 29.57 | 905.73 | 34.57 | | |
| TX2A | 6.05 | 29.57 | 905.73 | 34.57 | | |
| TX2B | 6.17 | 29.56 | 903.65 | 34.56 | | |
| Total | | 35.69 | 3708.23 | - | | |

Note 1. See worst-case TX1B in Graph 3
 Note 2. ERP =EIRP -2.15 dB as per [412172 D01](#)
 Note 3 As per [§22.913\(a\)\(1\)\(i\)](#)
 Note 4 The power was reduced to comply with [Clause 22.917 \(a\)](#)



PAPR - Carrier Bandwidth 5.0 MHz – Channel Position: 887.4MHz

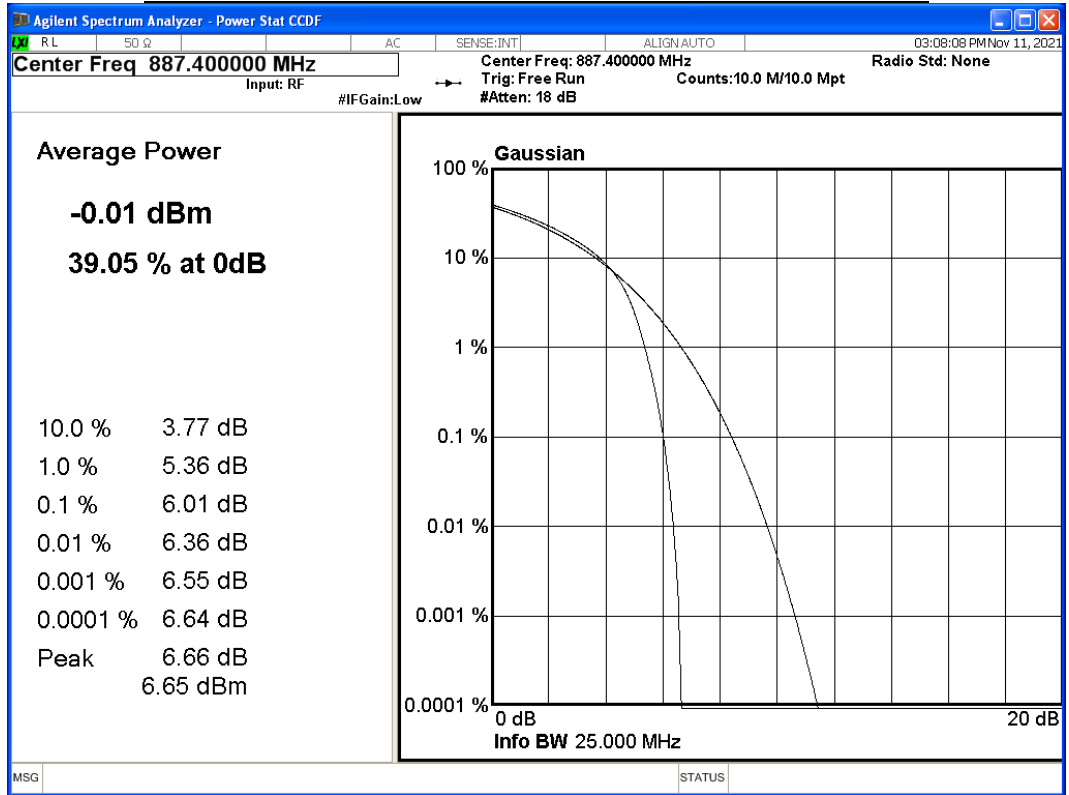



2.2 OCCUPIED BANDWIDTH

2.2.1 Specification Reference

FCC CFR 47 Part 2, Clause 2.1049
FCC CFR 47 Part 27, [Clause § 22.917](#)

2.2.2 Date of Test and Modification State

11 November 2021 - Modification State 0

2.2.3 Test Equipment Used

The major items of test equipment used for the above tests are identified in Section 3.1.

2.2.4 Environmental Conditions

| | |
|---------------------|--------|
| Ambient Temperature | 22.1°C |
| Relative Humidity | 16.4% |

2.2.5 Test Method

All measurements were made in accordance with FCC KDB 971168 D01.

2.2.6 Test Results

Maximum Output Power: Bottom- Middle- and Top- channels was 30 dBm; respectively. The worst-case scenario of all channels is provided below.



2.2.6.1 Bottom/Top Channel – 871.6 MHz

2.2.6.1.1 Worst Case – Port 2B

| Modulation | Carrier Bandwidth | Result (MHz) | |
|------------|-------------------|-------------------|------------------|
| | | Channel Bandwidth | -26 dB Bandwidth |
| QPSK | 4.2 MHz | 4.2 | 4.7 |

Bandwidth 5.0MHz – Modulation: QPSK – Channel B: 871.6 MHz

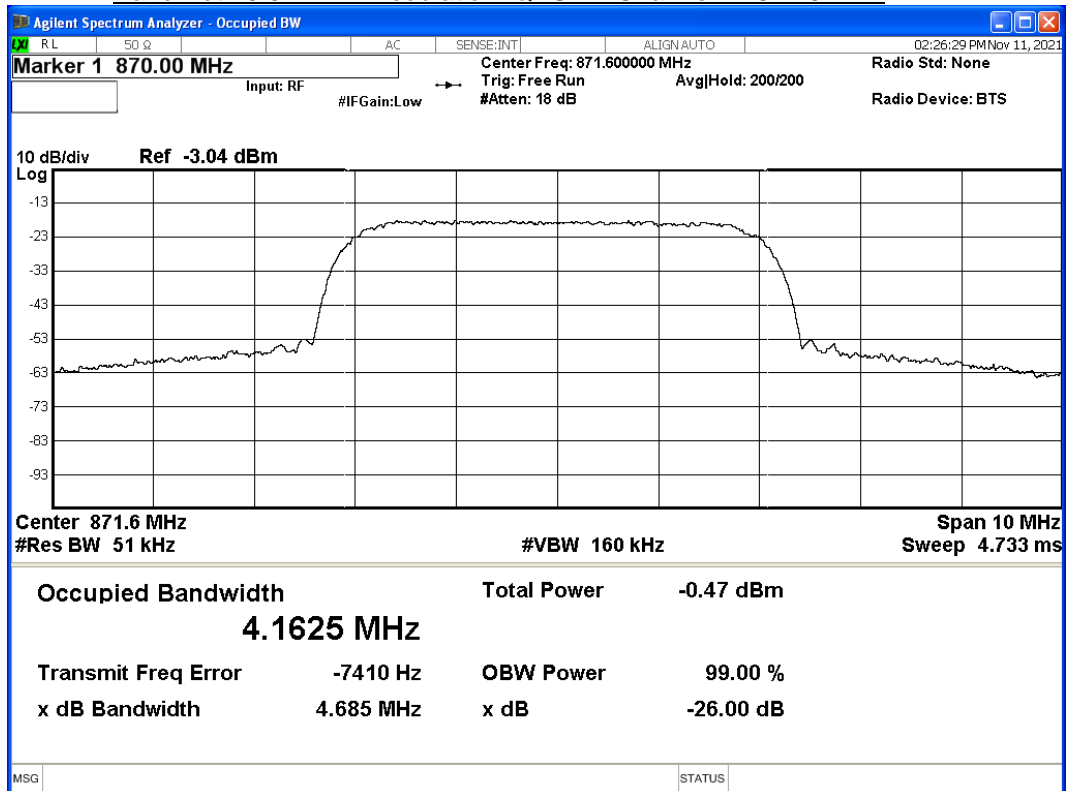



2.2.6.1 Bottom/Top Channel – 877.4 MHz

2.2.6.1.1 Worst Case – Port 2B

| Modulation | Carrier Bandwidth | Result (MHz) | |
|------------|-------------------|-------------------|------------------|
| | | Channel Bandwidth | -26 dB Bandwidth |
| QPSK | 5.0 MHz | 4.2 | 4.7 |

Bandwidth 5.0MHz – Modulation: QPSK – Channel B: 871.6 MHz

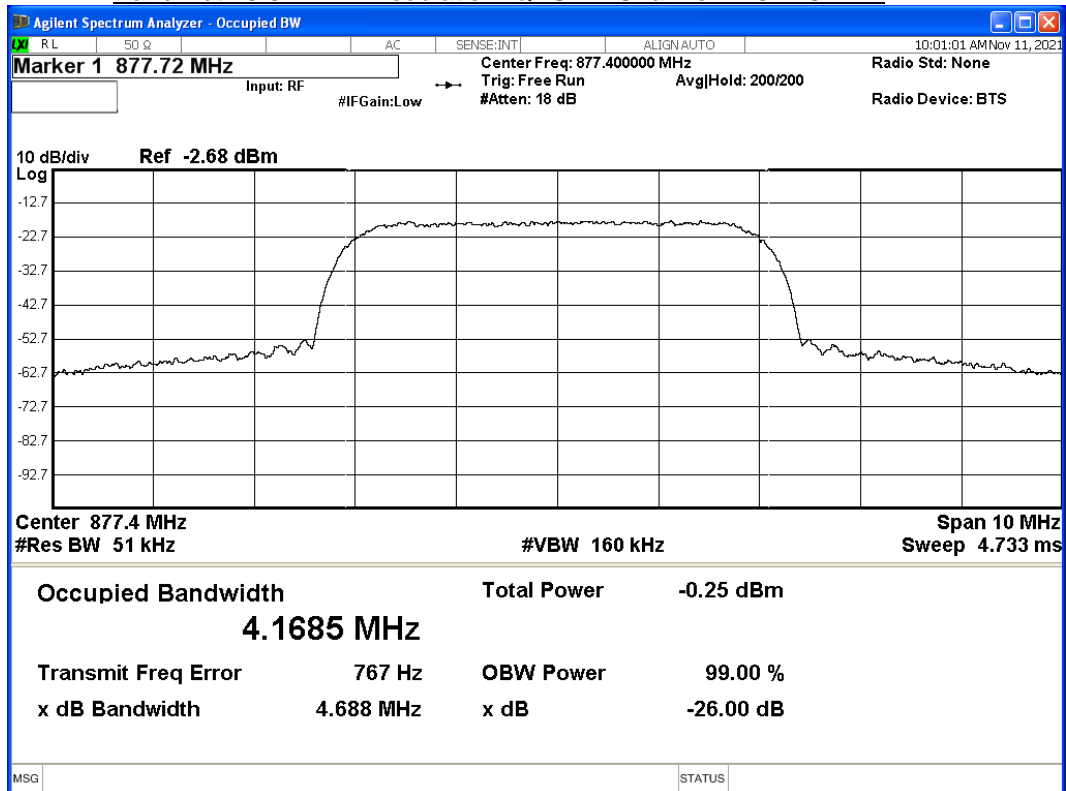



2.2.6.2 Middle Channel: 882.6 MHz

2.2.6.2.1 Worst Case – Port 1B

| Modulation | Carrier Bandwidth | Result (MHz) | |
|------------|-------------------|--------------------|------------------|
| | | Channel Bandwidth | |
| | | Occupied Bandwidth | -26 dB Bandwidth |
| QPSK | 5.0 MHz | 4.2 | 4.7 |

Bandwidth 5.0MHz – Modulation: QPSK – Channel Middle: 882.6 MHz

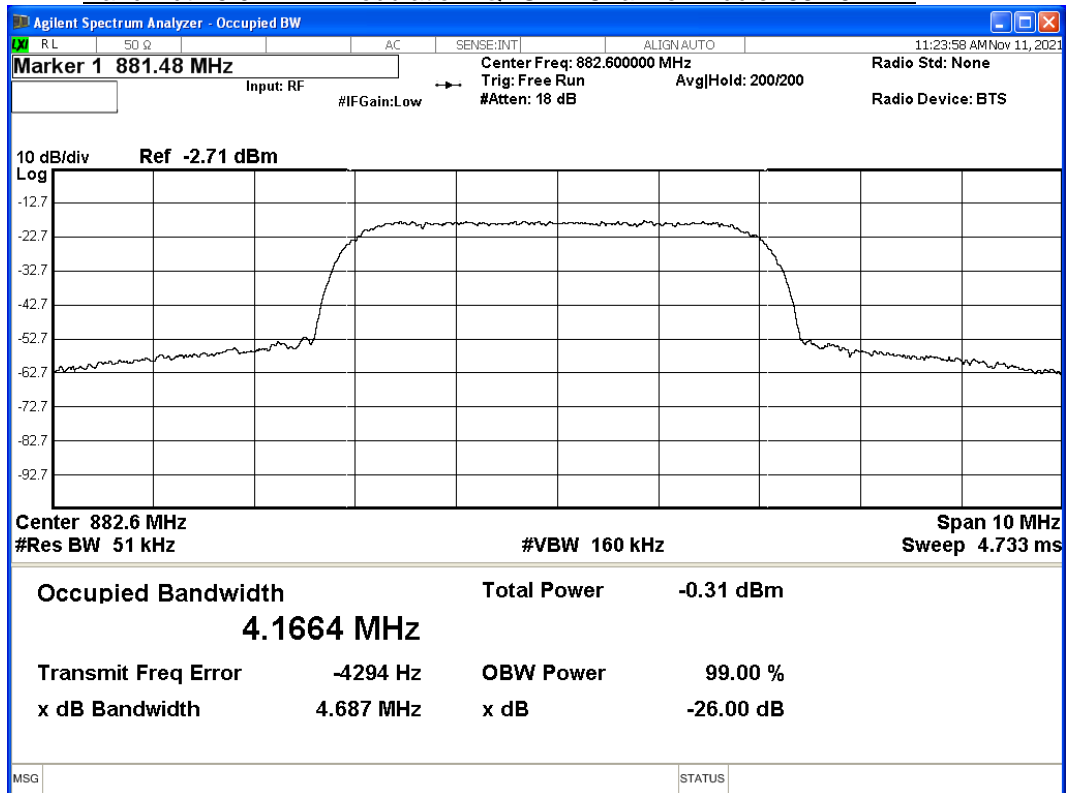



2.2.6.1 Top Channel – 887.4 MHz

2.2.6.1.1 Worst Case – Port 1A

| Modulation | Carrier Bandwidth | Result (MHz) | |
|------------|-------------------|--------------------|------------------|
| | | Channel Bandwidth | |
| | | Occupied Bandwidth | -26 dB Bandwidth |
| QPSK | 5.0 MHz | 4.5 | 4.8 |

Bandwidth 5.0MHz – Modulation: QPSK – Channel Top: 887.4 MHz

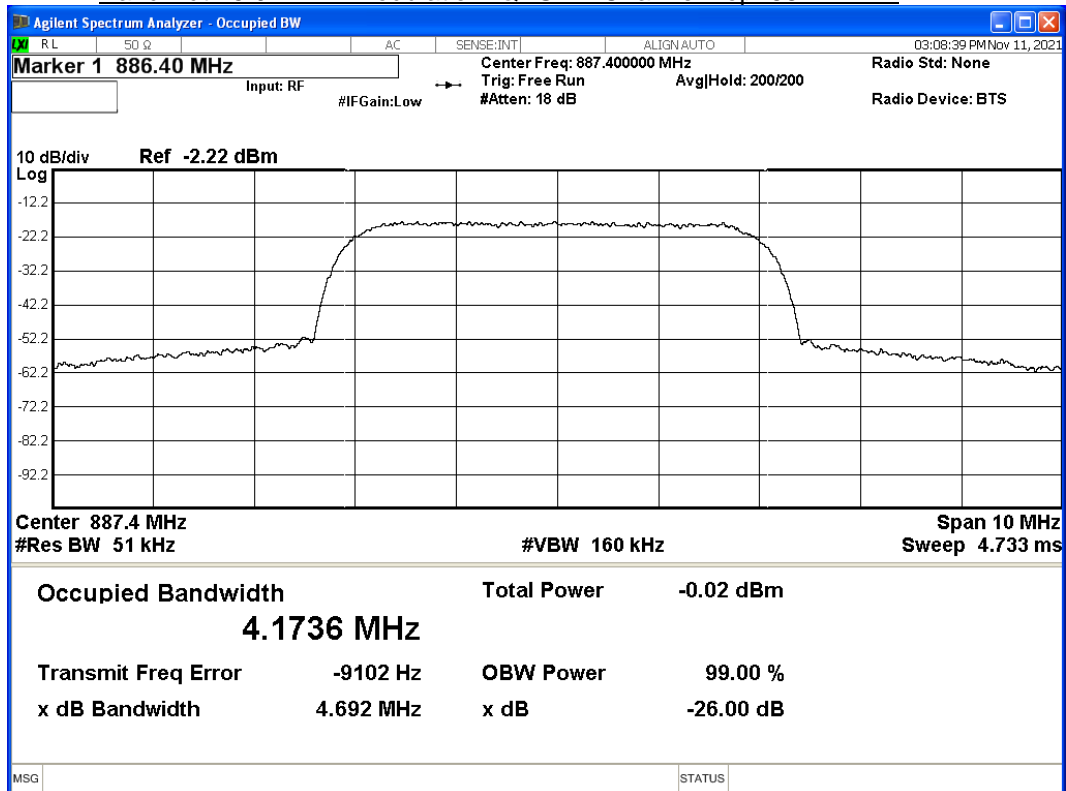



2.3 BAND EDGE

2.3.1 Specification Reference

FCC CFR 47 Part 2, Clause 2.1051
FCC CFR 47 Part 22, [Clause 22.917 \(a\)](#)

2.3.2 Date of Test and Modification State

11 November 2021 - Modification State 0

2.3.3 Test Equipment Used

The major items of test equipment used for the above tests are identified in Section 3.1.

2.3.4 Environmental Conditions

| | |
|---------------------|--------|
| Ambient Temperature | 24.1°C |
| Relative Humidity | 25.4% |

2.3.5 Test Method

All measurements were made in accordance with FCC KDB 971168 D01, clause 6. The EUT was connected to a Spectrum Analyser via an attenuator. The path loss between the EUT and the Spectrum Analyser was measured using a Network Analyser. The measured path loss was entered as a Reference Level Offset in the Spectrum Analyser. The Spectrum Analyser RBW was adjusted to be at least 1% of the measured 26dB Bandwidth. Using an RMS detector, the frequency spectrum up to 1MHz away from the Band Edge was Investigated.

The Spectrum Analyser RBW was adjusted to be at least 1% of the measured 26dB Bandwidth. Using an RMS detector, the frequency spectrum up to 1MHz from the band edge was investigated. The worst-case path loss in the measured ranges was entered as a reference level offset. Over the measured ranges, the RBW was set to 10kHz, however the band power function of the SA was used with an integration of 50kHz bandwidth. All measurement results are specified as average with an RMS detector being used in conjunction with a trace setting of Max Hold or clear write if representative. Measurements were performed in configurations of the EUT as reported below.

The EUT has one transmit port, testing was performed on this port with a test limit of $43+10 \times \log_{10}(P) + 10 \times \log_{10}(4) = -19$ dBm.



2.3.6 Test Results

Maximum Output Power: Bottom 30 dBm; Middle 30 dBm and Top 30 dBm. The band edges of middle channels were determined and only the worst scenario is provided.

2.3.6.1 Bottom Channel – 871.6 MHz

2.3.6.1.1 Worst Case – Port 2B

Maximum Target output Power: 30dBm

| Modulation | Carrier Bandwidth | Band Edge (MHz) | Channel Position B: | Band Power 100kHz | Band Power 50kHz |
|------------|-------------------|-----------------|---------------------|-------------------|------------------|
| | | | 871.6 | | |
| QPSK | 5.0 MHz | 869 –880 | Bottom | -23.17 | -26.54 |
| | | | Top | -46.20 | -49.07 |

Modulation QPSK – Bottom – Carrier Bandwidth 5.0 MHz - Channel Position: 871.6 MHz (Band Power 50kHz and 100kHz)

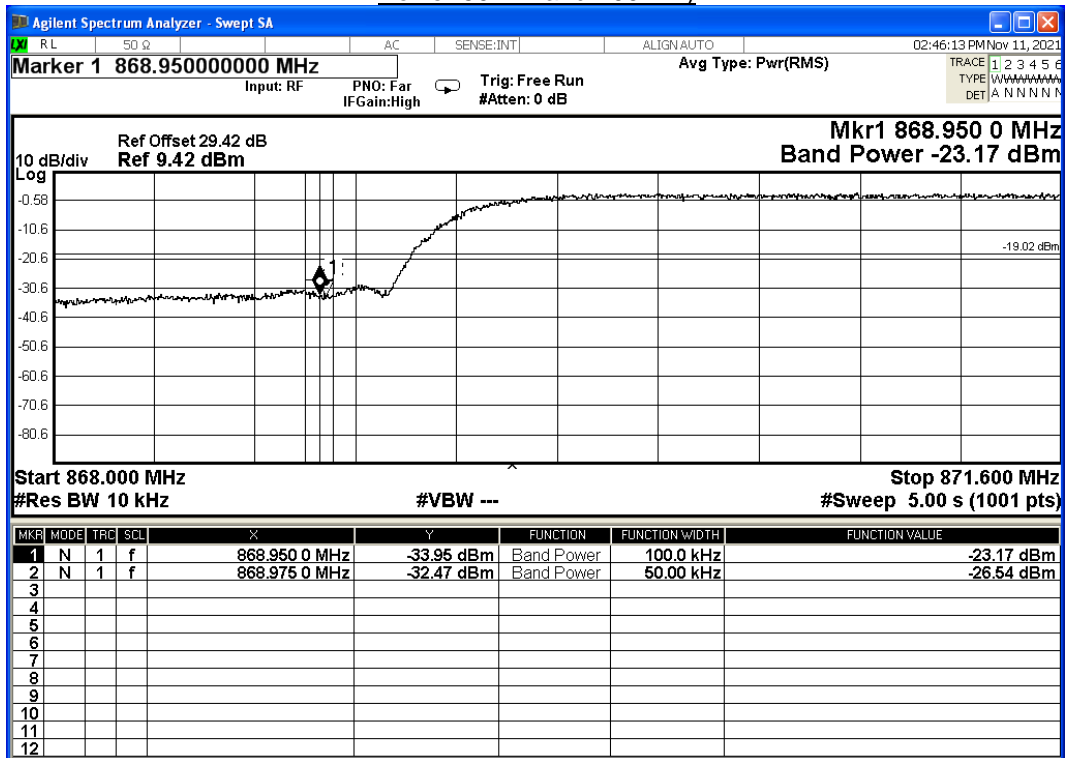



Modulation QPSK – Top – Carrier Bandwidth 5.0 MHz - Channel Position: 871.6 MHz (Band Power 50kHz and 100kHz)

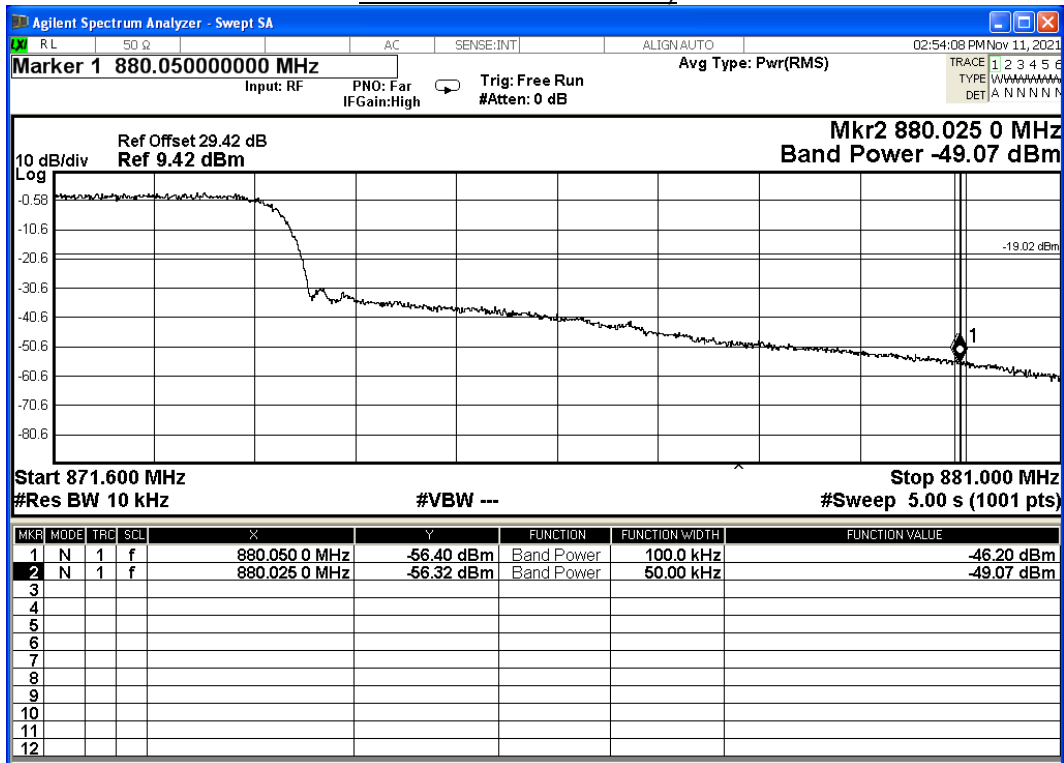



2.3.6.1 Bottom/Top Channel: 877.4MHz

Maximum Target output Power: 30 dBm

2.3.6.1.1 Worst Case – Port 2B

| Modulation | Carrier Bandwidth | Band Edge (MHz) | Channel Position B: | Band Power 100kHz | Band Power 50kHz | Band Power 30kHz |
|------------|-------------------|-----------------|---------------------|-------------------|------------------|------------------|
| | | | 877.4 | | | |
| QPSK | 5.0 MHz | 869 –880 | Bottom | -46.04 | -48.77 | -50.70 |
| | | | Top | -25.33 | -29.01 | -31.45 |

Modulation QPSK – Bottom - Carrier Bandwidth 4.2.0 MHz - Channel Position: 877.4MHz (Band Power 30kHz, 50kHz and 100kHz)

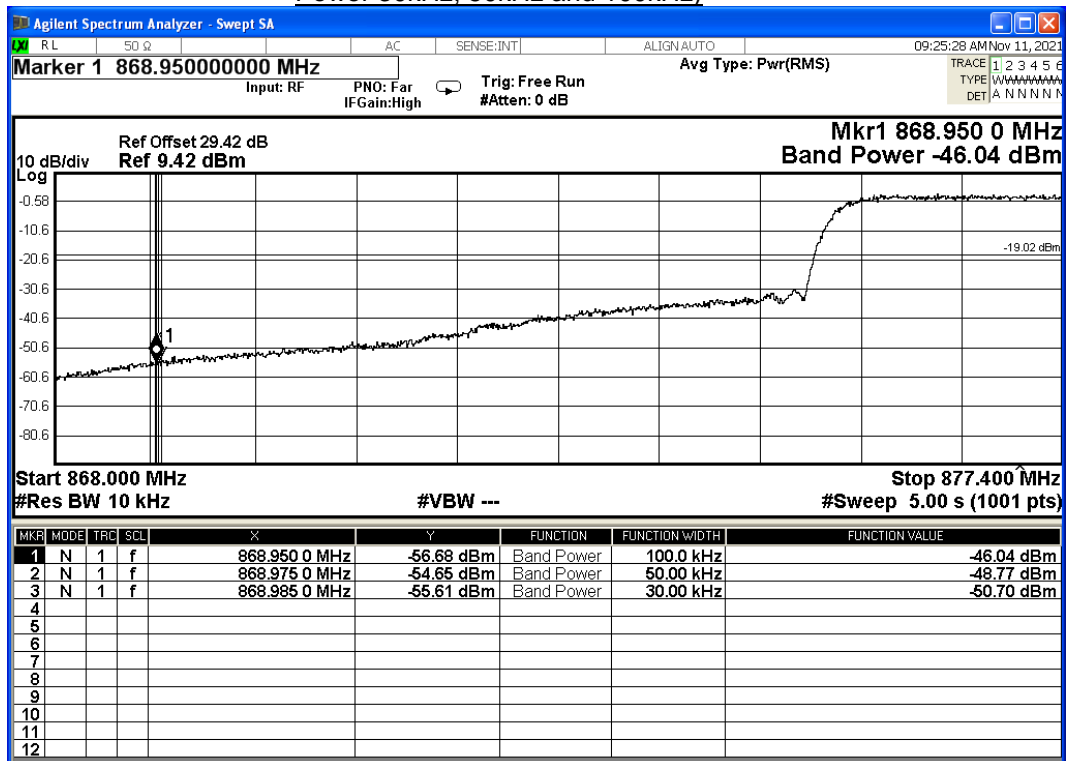



Modulation QPSK – Top- Carrier Bandwidth 5.0 MHz - Channel Position: 887.4MHz (Band Power 30kHz, 50kHz and 100kHz)

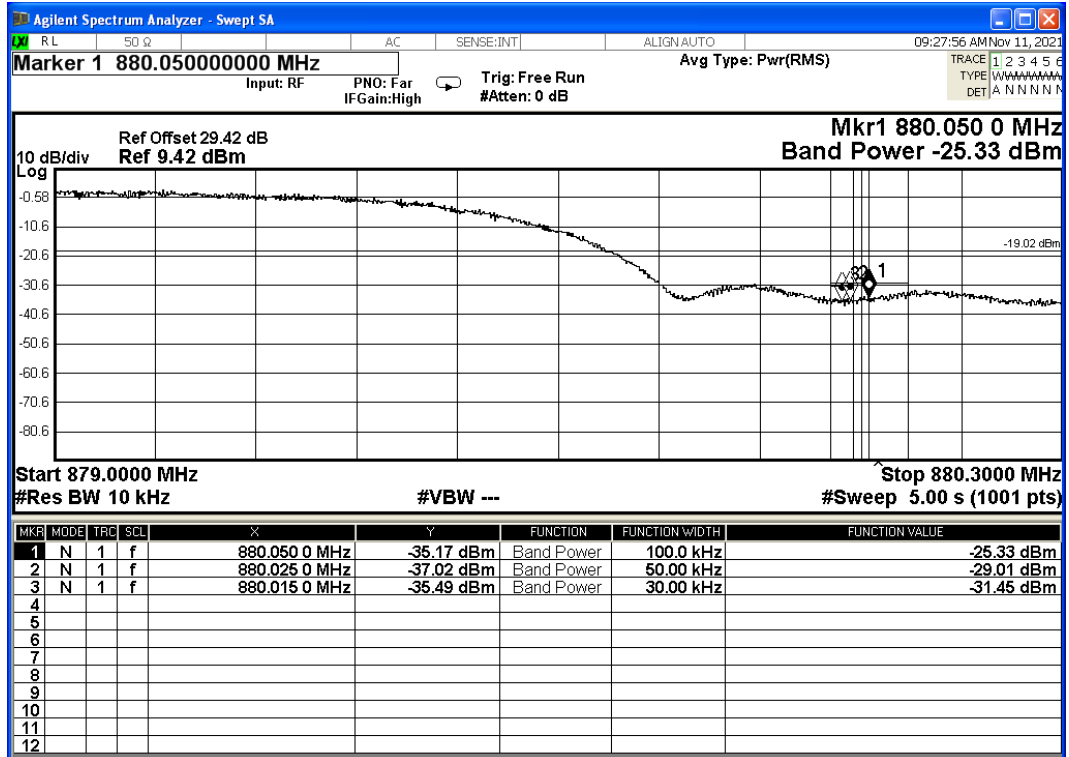



2.3.6.2 Bottom/Top Channel: 882.6MHz

Maximum Target output Power: 30 dBm

2.3.6.2.1 Worst Case – Port 2B

| Modulation | Carrier Bandwidth | Band Edge (MHz) | Channel Position B: | Band Power 100kHz | Band Power 50kHz |
|------------|-------------------|-----------------|---------------------|-------------------|------------------|
| | | | 882.6 | | |
| QPSK | 5.0 MHz | 880 –890 | Bottom | -22.71 | -26.11 |
| | | | Top | -41.89 | -44.88 |

Modulation QPSK – Bottom – Carrier Bandwidth 5.0 MHz - Channel Position: 882.6 MHz (Band Power 50kHz and 100kHz)

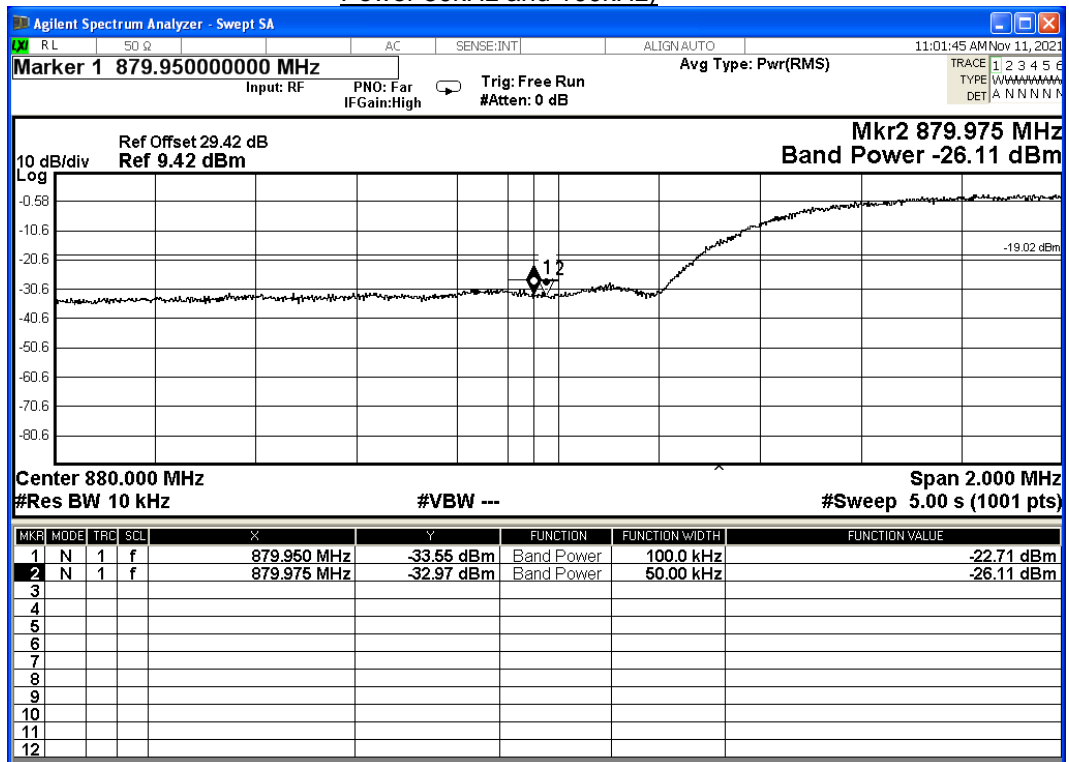



Modulation QPSK – Top – Carrier Bandwidth 5.0 MHz - Channel Position: 882.6 MHz (Band Power 50kHz and 100kHz)

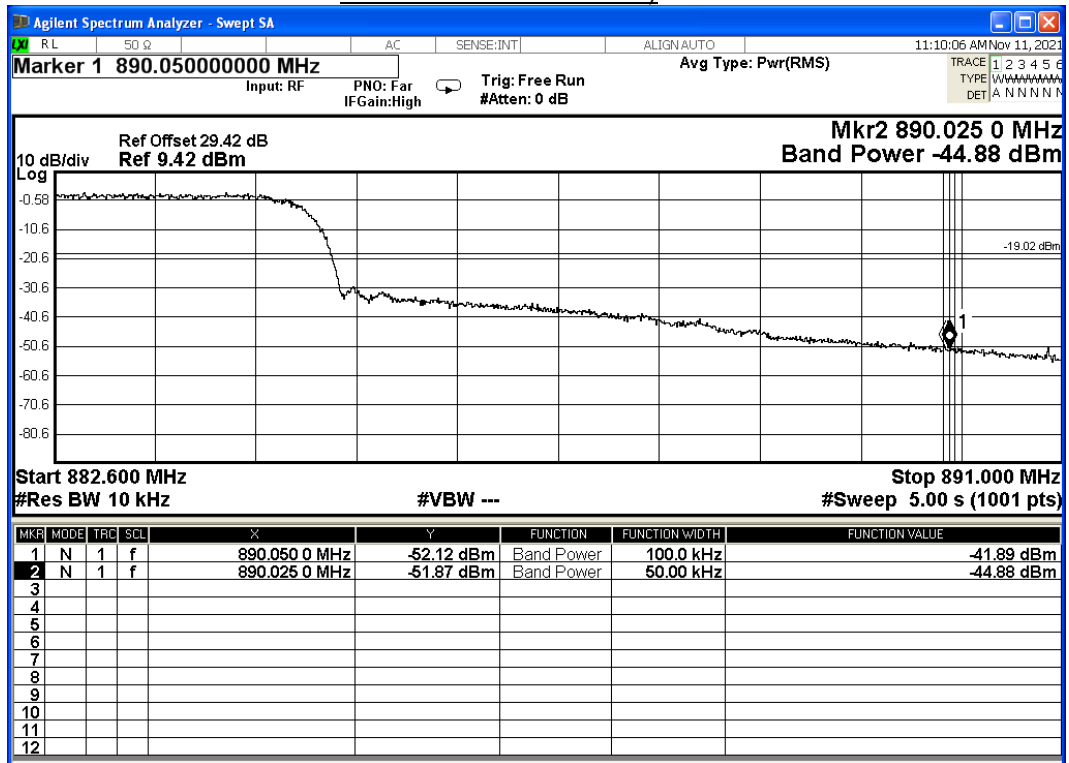



2.3.6.3 Bottom/Top Channel: 887.4MHz

Maximum Target output Power: 30 dBm

2.3.6.3.1 Worst Case – Port 1A

| Modulation | Carrier Bandwidth | Band Edge (MHz) | Channel Position B: | Band Power 100kHz | Band Power 50kHz |
|------------|-------------------|-----------------|---------------------|-------------------|------------------|
| | | | QPSK | 5.0 MHz | 880 –890 |
| | | | Bottom | -39.96 | -43.03 |
| | | | Top | -23.02 | -26.45 |

Modulation QPSK – Bottom – Carrier Bandwidth 5.0 MHz - Channel Position: 887.4 MHz (Band Power 50kHz and 100kHz)

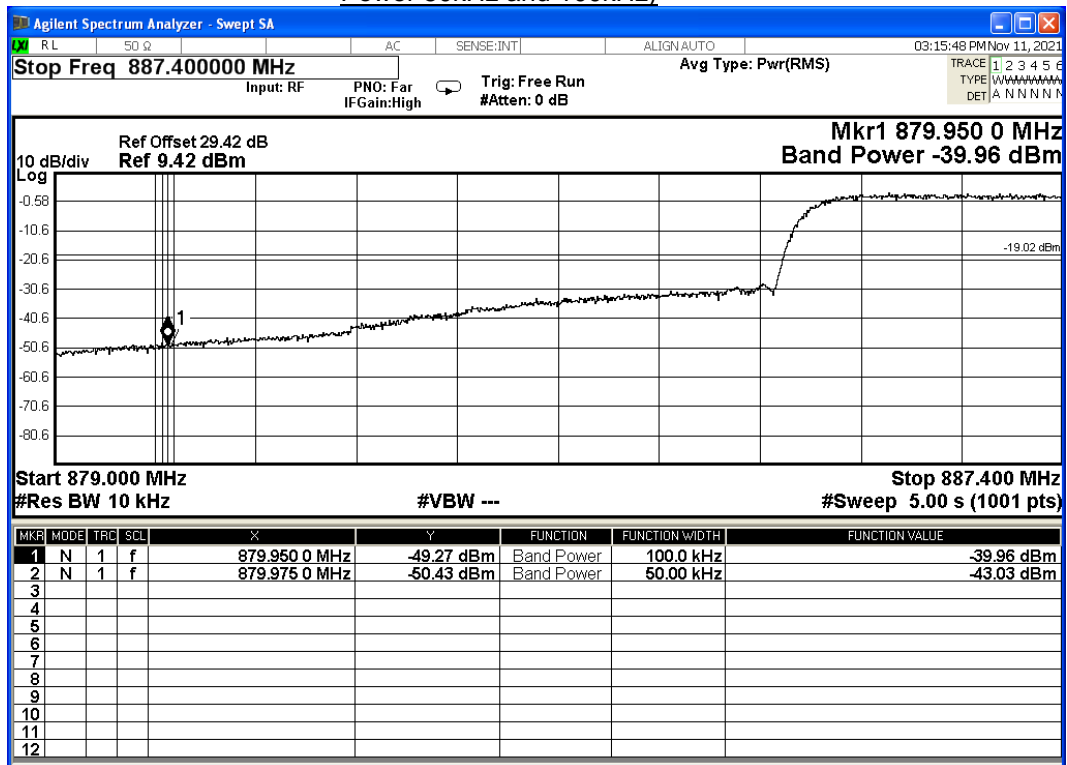



Modulation QPSK – Top – Carrier Bandwidth 5.0 MHz - Channel Position: 887.4 MHz (Band Power 50kHz and 100kHz)

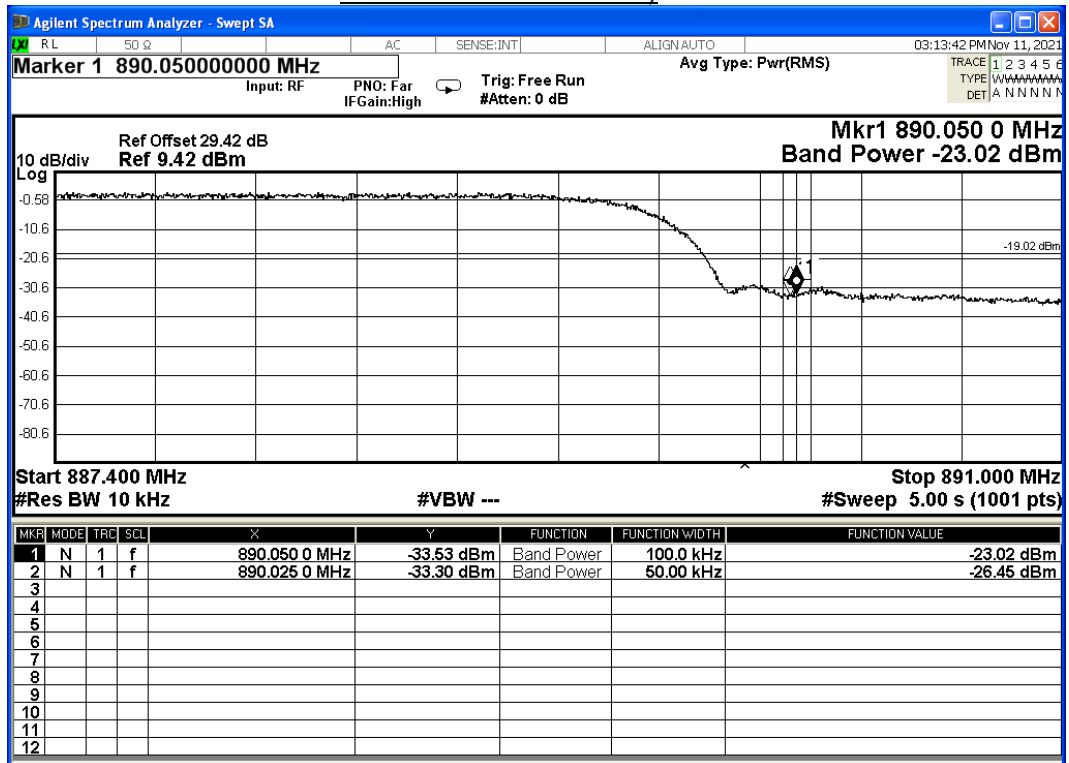



2.4 TRANSCEIVER SPURIOUS EMISSIONS

2.4.1 Specification Reference

FCC CFR 47 Part 2, Clause 2.1051
FCC CFR 47 Part 22, [Clause §22.357](#)

2.4.2 Date of Test and Modification State

11 November 2021- Modification State 0

2.4.3 Test Equipment Used

The major items of test equipment used for the above tests are identified in Section 3.1.

2.4.4 Environmental Conditions

| | |
|---------------------|--------|
| Ambient Temperature | 25.1°C |
| Relative Humidity | 16.4% |

2.4.5 Test Method

All measurements were made in accordance with FCC KDB 971168 D01.

All measurements were made in accordance with FCC KDB 971168 D01 Clause 6. The EUT was connected to a Spectrum Analyser via an attenuator and switching box. Prior to testing, a Network Analyser was used to calibrate the path loss between the EUT and the Spectrum Analyser. The worst-case path loss in the measured ranges was entered as a reference level offset. Over the measured ranges, the RBW was set to 1MHz with a VBW of 3MHz. All measurement results are specified as average with an RMS detector being used in conjunction with a trace setting of Max Hold. Measurements were performed in configurations of the EUT as reported below. Testing was performed on this port with a test limit of $43+10 \times \log_{10}(P) + 10 \times \log_{10}(4) = -19$ dBm.



2.4.6 Test Results

| Range Frequency | Limit (dBm) | Result |
|--|-------------|------------------|
| 9kHz to 1GHz | -19 | Pass |
| 1GHz to 5G | -19 | Pass |
| 5G to 26GHz | -19 | Pass |
| 26GHz to 40GHz | -19 | Pass <Note 1> |
| Note 1. The device was scanned up to 40Ghz with no emission (peak values less than 6Bd from the limit) | | |

2.4.6.1.1 Worst Case – Port 1A

Modulation QPSK - Carrier Bandwidth 5.0 MHz – Range 9kHz to 500MHz

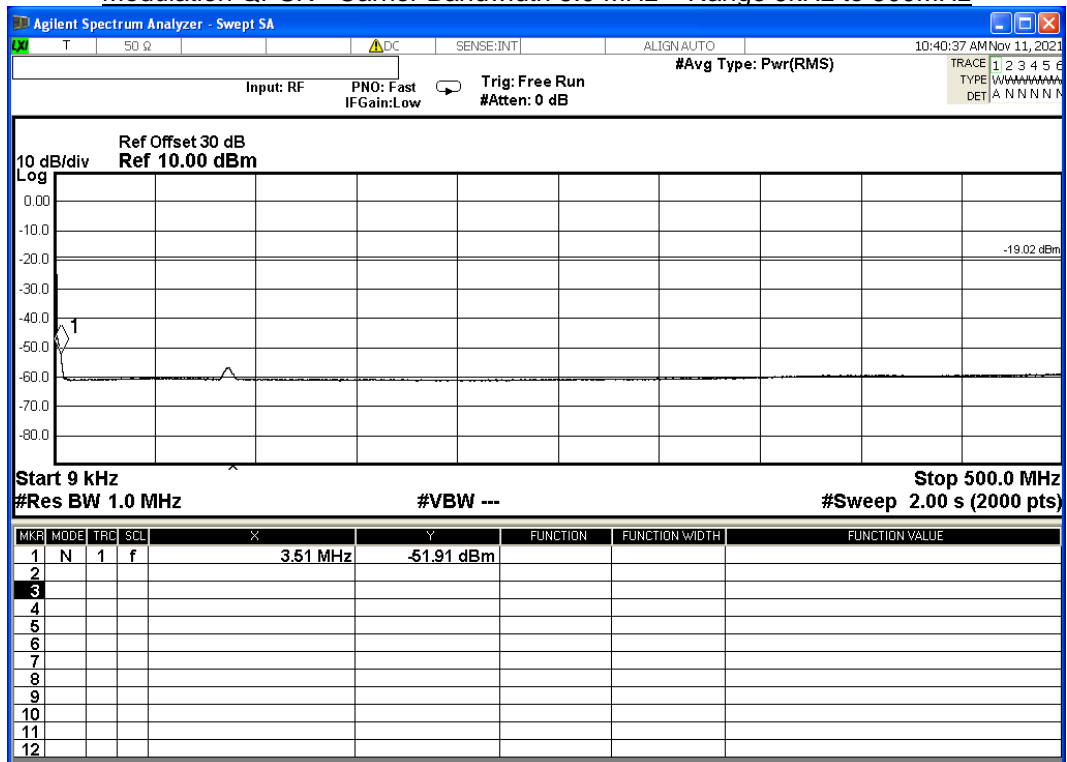



Modulation QPSK - Carrier Bandwidth 5.0 MHz – Range 500MHz to 5GHz: 871.6 MHz

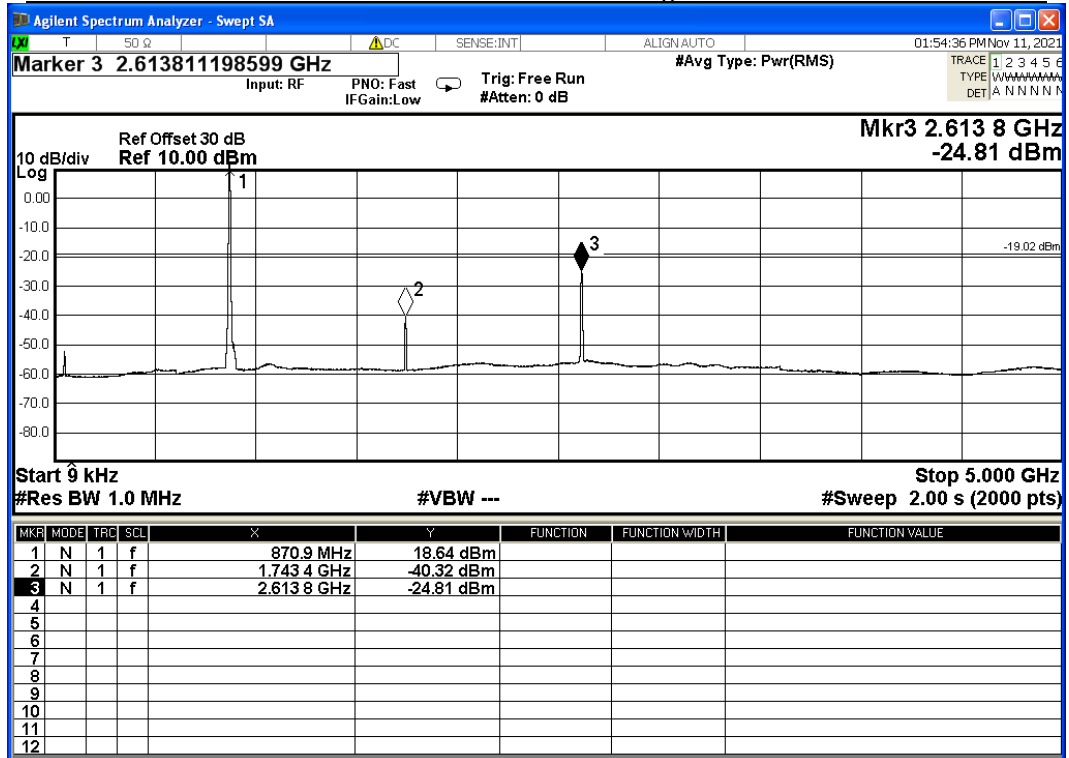

Modulation QPSK - Carrier Bandwidth 5.0 MHz – Range 500MHz to 5GHz: 877.4MHz

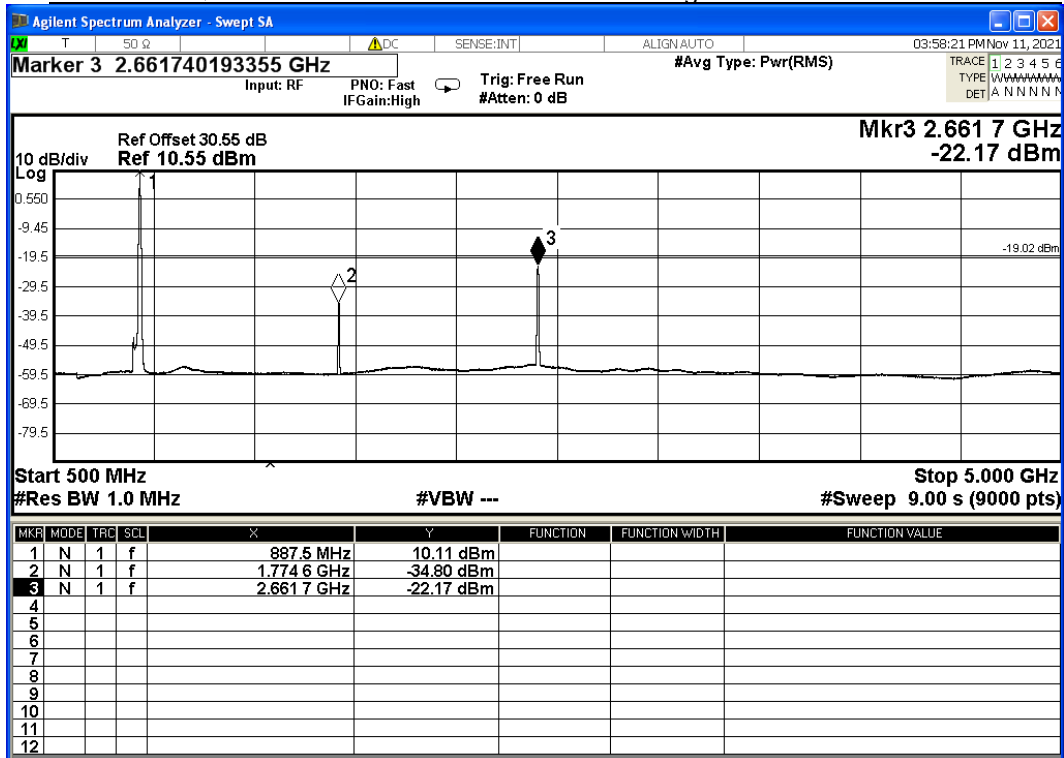



Modulation QPSK - Carrier Bandwidth 5.0 MHz – Range 500MHz to 5GHz: 882.6 MHz

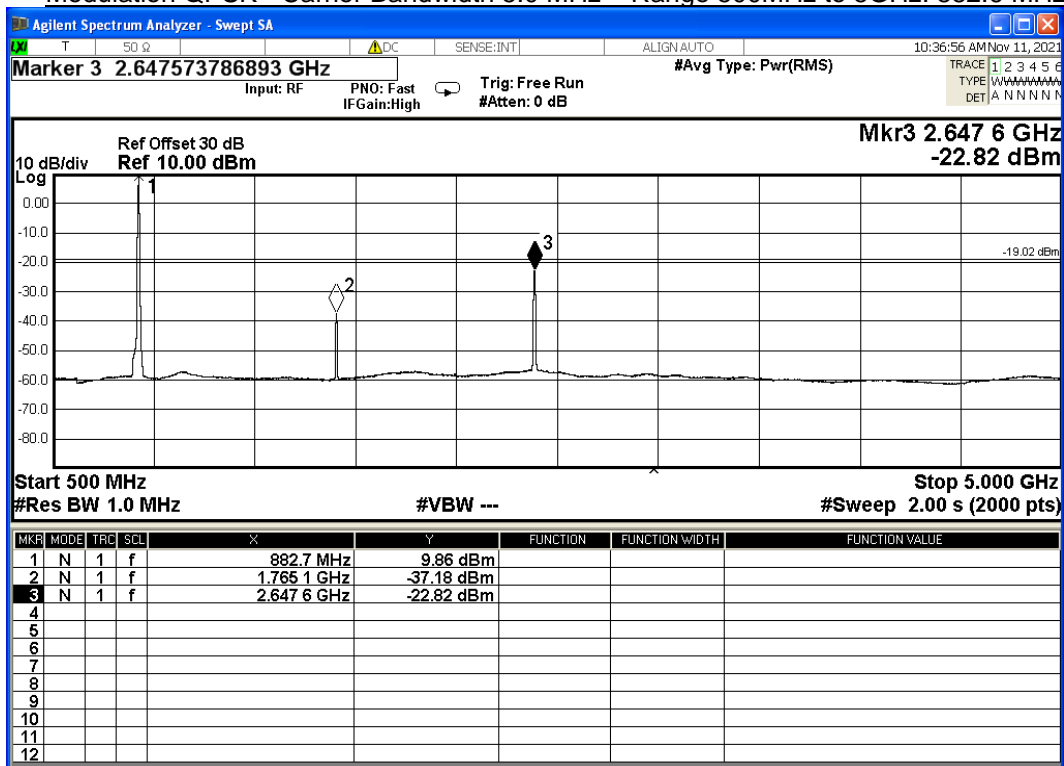



Modulation QPSK - Carrier Bandwidth 5.0 MHz – Range 500MHz to 1GHz: 887.4 MHz

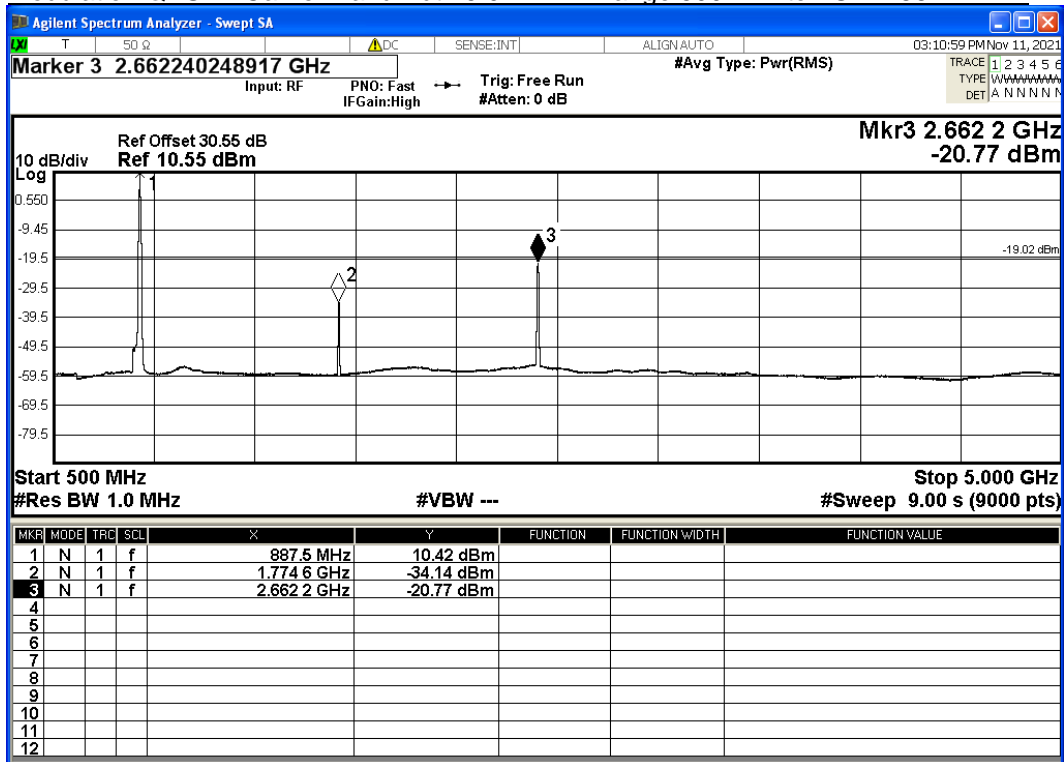

Modulation QPSK - Carrier Bandwidth 5.0 MHz – Range 5GHz to 26GHz

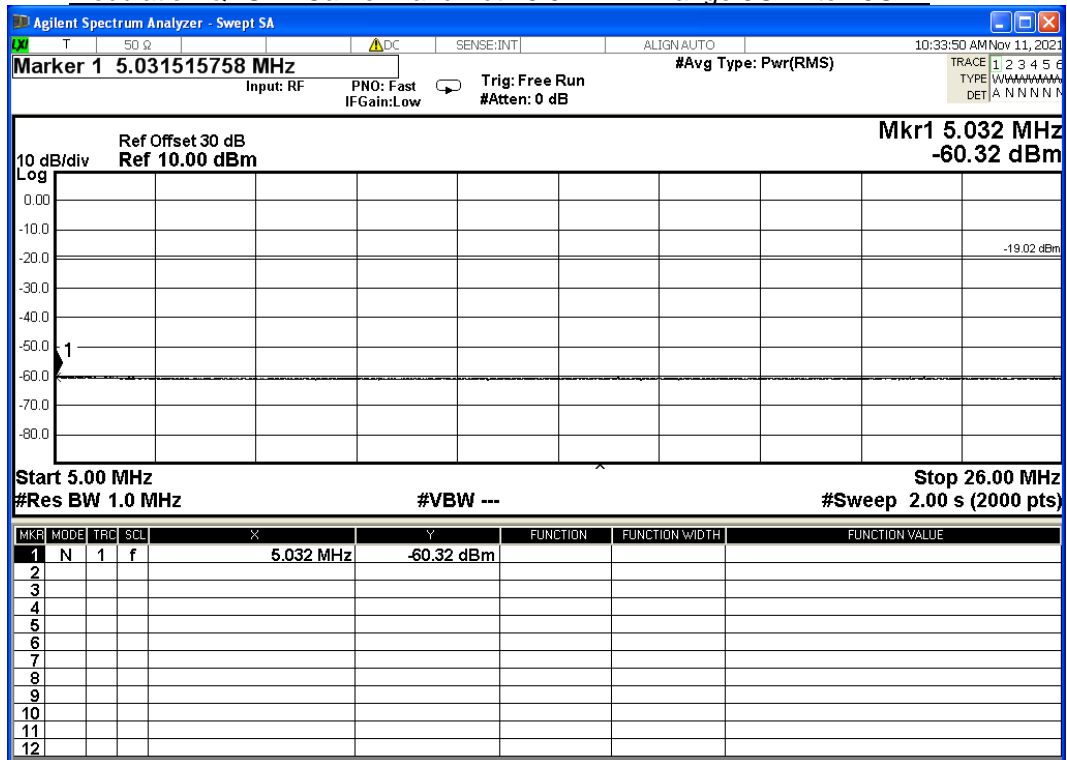



2.5 FREQUENCY STABILITY

2.5.1 Specification Reference

FCC CFR 47 Part 2, Clause 2.1055
 FCC CFR 47 Part 27, [Clause 22.355](#)

2.5.2 Date of Test and Modification State

22 June 2021 - Modification State 0

2.5.3 Test Equipment Used

The major items of test equipment used for the above tests are identified in Section 3.1.

2.5.4 Environmental Conditions

Ambient Temperature 26.7°C
 Relative Humidity 32.2%

2.5.5 Test Method

All measurements were made in accordance with FCC KDB 971168 D01.

2.5.6 Test Results

Maximum Target Output Power 30dBm

2.5.6.1.1 Worst Case – Port 1A

| Temperature | Voltage (AC) | Frequency Error (Hz) | Limit ppm <Note 2> | Error/Freq ppm | Result |
|---|--------------|----------------------|--------------------|----------------|----------|
| -30°C | 115 | Note 1 | ±1.5 | N/A | <Note 1> |
| -20°C | 115 | 87.24 | ±1.5 | 0.10 | Pass |
| -10°C | 115 | 34.21 | ±1.5 | 0.04 | Pass |
| 0°C | 115 | 31.0 | ±1.5 | 0.03 | Pass |
| +10°C | 115 | 20.50 | ±1.5 | 0.02 | Pass |
| +20°C | 115 | 22.7 | ±1.5 | 0.03 | Pass |
| +20°C | 90 | 21.22 | ±1.5 | 0.02 | Pass |
| +20°C | 132 | 13.17 | ±1.5 | 0.01 | Pass |
| +30°C | 115 | 16.34 | ±1.5 | 0.02 | Pass |
| +40°C | 115 | 18.30 | ±1.5 | 0.02 | Pass |
| +55°C | 115 | 4.62 | ±1.5 | 0.005 | Pass |
| Note 1. EUT stop the operation and no transmission was recorded: Pass The frequency stability shall be sufficient to ensure that the fundamental emissions stay within the authorized bands of operation Note 2. Frequency Range 821 to 896 of Table C-1 in §22.355 | | | | | |



2.6 FIELD STRENGTH

2.6.1 Specification Reference

FCC CFR 47 Part 2.1053
FCC CFR 47 Part 90, Clause [§ 22.983](#)

2.6.2 Date of Test and Modification State

June 22, 2021 – Modification State 0
June 23, 2021 – Modification State 0
July 5th, 2021 – Modification State 0

2.6.3 Test Equipment Used

The major items of test equipment used for the above tests are identified in Section 3.1.

2.6.4 Environmental Conditions

| | |
|---------------------|--------|
| Ambient Temperature | 23.1°C |
| Relative Humidity | 13.4% |

2.6.5 Test Method

All measurements were made in accordance with:

- 971168 D01 Power Meas License Digital Systems v03r01 Clause 5.6
- 971168 D01 Power Meas License Digital Systems v03r01 Clause 7

From Clause 5:6, the field strength of the EUT can be calculated by:

$$\text{EIRP} = P_{\text{meas}} + A_{\text{gain}} = 30 \text{ dBm} + 5\text{dBi} = 35\text{dBm} \text{ (or } 127.23 \text{ dB}\mu\text{V/m at } 3\text{m)}$$

Measurements were performed in configurations of the EUT as reported below. Testing was performed with RF on (Port TX1A) with a test limit of FCC 15 Subpart B Class B of 40 dB μ V/m, which is more restricted than -19 dBm or 76.23 dB μ V/m at 3m.



2.6.6 Test Results

A summary of the test result is depicted in the table below.

| Range Frequency | Test Limit (dB μ V/m) | Limit <Note 1> dB μ V/m | Result |
|-----------------|---------------------------|-----------------------------|---------------|
| 9kHz to 150kHz | 40.0 | 76.23 | Pass <Note 2> |
| 150kHz to 30MHz | 40.0 | 76.23 | Pass |
| 30MHz to 1GHz | 33.06 | 76.23 | Pass |
| 1GHz to 10GHz | 53.96 | 76.23 | Pass |
| 10GHz to 18GHz | 53.96 | 76.23 | Pass |
| 18GHz to 40GHz | 53.96 | 76.23 | Pass <Note 3> |

Note 1. As per CFR 47 27.55(a)(1)
Note 2. No significant emission (> 20dB margin below the limit) was recorded according to FCC 15 Subpart B.
Note 3. The device was scanned up to 40Ghz with no emission (peak values less than 6Bd from the limit)



Spurious Radiation
Spurious Radiation Emission – 150kHz to 30MHz

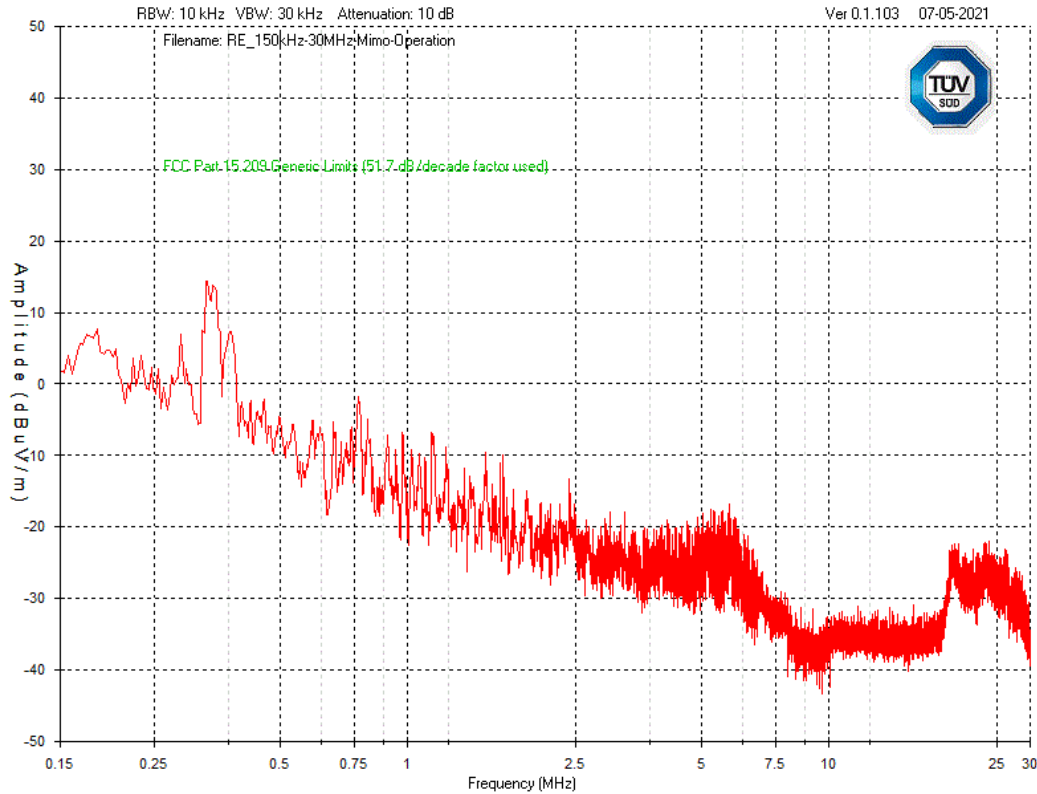

Note 1. The spurious emissions comply with the limit of 76.23 dB μ V/m at 3m.

| Frequency (MHz) | Detector | Raw Reading | Cable 27 - 10m LMR4 00 Factor | Loop - EM687 2 100k to 30M Factor | Pream p-LNA14 50 Factor | Level | FCC Part 15.209 Generic Limits (51.7 dB/decade factor used) Limit | FCC Part 15.209 Generic Limits (51.7 dB/decade factor used) Margin |
|-----------------|----------|-------------|-------------------------------|-----------------------------------|-------------------------|-------|---|--|
| 0.7642 | PEAK | 31.4 | 0 | -2.3 | -31 | -1.9 | 93.3 | 95.2 |
| 1.6872 | PEAK | 28.5 | 0.1 | -7.4 | -31.1 | -9.9 | 86.4 | 96.3 |
| 1.1427 | PEAK | 28.7 | 0.1 | -4.5 | -31 | -6.7 | 89.8 | 96.5 |
| 1.5378 | PEAK | 28 | 0.1 | -6.6 | -31 | -9.5 | 87.2 | 96.7 |



Spurious Radiation Emission –30MHz to 1GHz

"TÜV SÜD, by release of this raw data, does not imply that the tested product has demonstrated compliance to any standard. The raw data provided may not be complete and may require additional processing. If raw data provided includes engineering data, testing may not have been done according to a standard test method. "

| Emi CC test:RE_30-1000 MHz 10m - FCC- Class B Number:122 Execution date: 6/22/2021 1:42:24 PM | |
|---|--|
| Limit | FCC Part 15 Subpart B |
| Class | Class : B |
| Test Plan Number | 7169009211 |
| Configuration Information | Mode: Operating: Band:891.5MHz (30dBm) |
| Results | Pass |
| Model | CBRSYS4450 |
| Tested by | KP and SM |
| Comments | Port activated: TX1A |

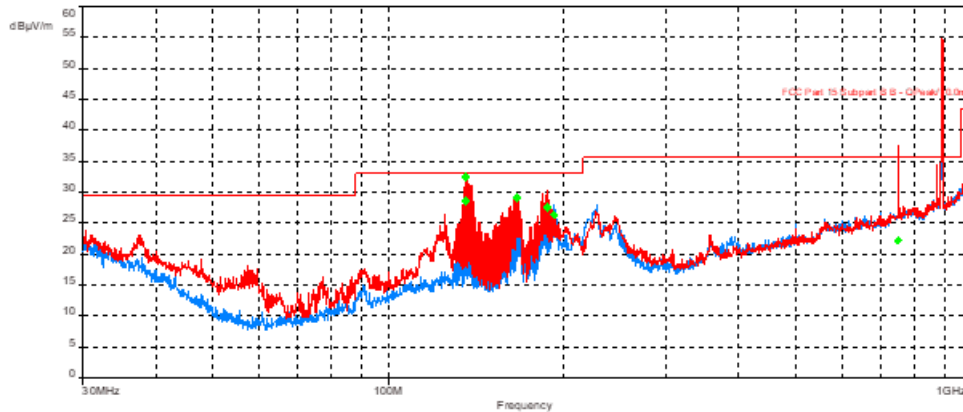

Red=Vertical, Blue=Horizontal

Finals

Quasi-Peak Detector (6)

| Frequency (MHz) | S R | Level (dBµV/m) | Limit (dBµV/m) | Margin (dB) | Height (m) (dB) | Azimuth (°) (dB) | Polarization (dB) | Correction (dB) |
|-----------------|-----|----------------|----------------|-------------|-----------------|------------------|-------------------|-----------------|
| 135.8700672 | 1 | 32.42 | 33.06 | -0.64 | 1.00 | 117.75 | Vertical | -9.37 |
| 166.2925738 | 1 | 29.15 | 33.06 | -3.91 | 1.11 | 175.25 | Vertical | -10.68 |
| 187.5651795 | 1 | 27.54 | 33.06 | -5.52 | 1.06 | 119.75 | Vertical | -11.92 |
| 749.9822821 | 1 | 22.16 | 35.56 | -13.40 | 1.84 | 220.75 | Vertical | 3.69 |
| 135.8608141 | 2 | 28.49 | 33.06 | -4.57 | 4.00 | 112.75 | Horizontal | -9.37 |
| 192.6622692 | 2 | 26.30 | 33.06 | -6.76 | 3.40 | 127.25 | Horizontal | -11.80 |

Note 1. The spurious emissions comply with the limit of 76.23 dBµV/m at 3m.

Note 2. Operating at 887.4MHz, thus emission excluded from FCC limit.



Spurious Radiation Emission –1GHz to 10GHz

"TÜV SÜD, by release of this raw data, does not imply that the tested product has demonstrated compliance to any standard. The raw data provided may not be complete and may require additional processing. If raw data provided includes engineering data, testing may not have been done according to a standard test method. "

| Emi CC test:RE_1-10 GHz 3m - MIMO- FCC Class B Number:129 Execution date: 6/22/2021 3:15:43 PM | |
|--|-----------------------|
| Limit | FCC Part 15 Subpart B |
| Class | Class: B |
| Test Plan Number | 7169009211 |
| Configuration Information | Mode: Operating |
| Results | Pass |
| Model | CBRSYS4450 |
| Tested by | KP and SM |
| Comments | Port activated: TX1A |

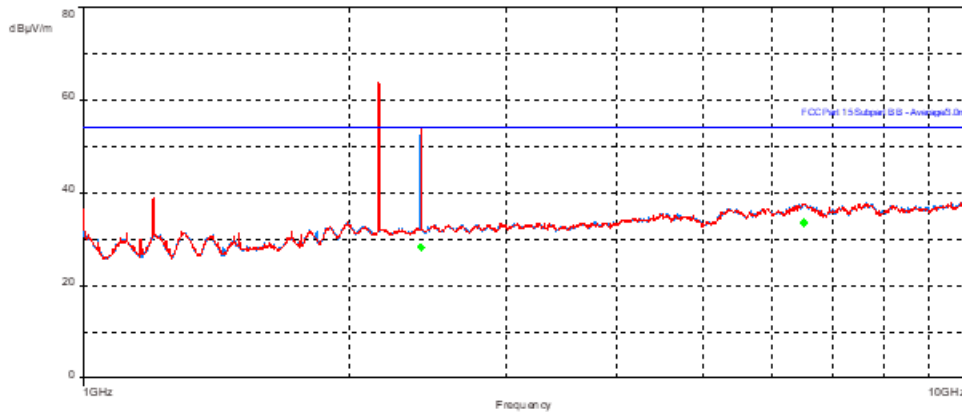

Red=Vertical, Blue=Horizontal

Finals

| AVG (4) | | | | | | | | |
|-----------------|----|----------------|----------------|-------------|-----------------|------------------|-------------------|-----------------|
| Frequency (MHz) | SR | Level (dBµV/m) | Limit (dBµV/m) | Margin (dB) | Height (m) (dB) | Azimuth (°) (dB) | Polarization (dB) | Correction (dB) |
| 2405.726603 | 1 | 28.27 | 53.96 | -25.69 | 3.69 | 9.50 | Vertical | -5.79 |
| 6492.401603 | 1 | 33.47 | 53.96 | -20.49 | 2.08 | 343.00 | Vertical | 1.37 |
| 2403.416346 | 2 | 28.38 | 53.96 | -25.58 | 1.00 | 356.75 | Horizontal | -5.81 |
| 6513.693269 | 2 | 33.56 | 53.96 | -20.40 | 2.42 | 2.25 | Horizontal | 1.35 |

Note 1. The spurious emissions comply with the limit of 76.23 dBµV/m at 3m.

Note 2. 2.4GHz peak correspond to the computer WIFI communication.



Spurious Radiation Emission –10GHz to 18GHz

"TÜV SÜD, by release of this raw data, does not imply that the tested product has demonstrated compliance to any standard. The raw data provided may not be complete and may require additional processing. If raw data provided includes engineering data, testing may not have been done according to a standard test method. "

| Emi CC test:RE_10-18 GHz 3m - MIMO - FCC Class B Number:135 Execution date: 6/23/2021 8:42:04 AM | |
|--|----------------------------------|
| Limit | FCC Part 15 Subpart B |
| Class | Class: B |
| Test Plan Number | 7169009211 |
| Configuration Information | Operation: Band:891.5MHz (30dBm) |
| Results | Pass |
| Model | CBRSYS4450 |
| Tested by | KP and SM |
| Comments | Port activated: TX1A |



Red=Vertical, Blue=Horizontal

Finals

AVG Detector (4)

| Frequency (MHz) | S R | Level (dBµV/m) | Limit (dBµV/m) | Margin (dB) | Height (m) (dB) | Azimuth (°) (dB) | Polarization (dB) | Correction (dB) |
|-----------------|-----|----------------|----------------|-------------|-----------------|------------------|-------------------|-----------------|
| 16750.52277 | 2 | 41.61 | 53.96 | -12.35 | 1.00 | 10.50 | Horizontal | 14.25 |
| 16753.59519 | 1 | 41.97 | 53.96 | -11.99 | 4.00 | 271.50 | Vertical | 14.29 |
| 17898.35513 | 2 | 41.39 | 53.96 | -12.57 | 3.86 | 16.75 | Horizontal | 14.87 |
| 17916.38559 | 1 | 41.10 | 53.96 | -12.86 | 1.00 | 0.00 | Vertical | 14.82 |

Note 1. The spurious emissions comply with the limit of 76.23 dBµV/m at 3m.



SECTION 3: TEST EQUIPMENT USED



3.1 TEST EQUIPMENT USED

List of absolute measurements and other principal items of test equipment.

| Instrument | Manufacturer | Type No. | Serial No. | Calibration Period (months) | Calibration Due |
|--|-----------------|------------------------|------------|-----------------------------|-----------------|
| Bilog Antenna | TESEQ | CBL 6111D | SSG013965 | 2021-05-04 | 2022-05-04 |
| Horn Antenna 3MCH 00003 | ETS | 3117 | LAVE04211 | 2021-03-30 | 2022-03-30 |
| EMI Receiver | Rohde & Schwarz | ESU26 | SSG013729 | 2021-03-31 | 2022-03-31 |
| EMI Receiver | Rohde & Schwarz | ESU40 | SSG013672 | 2020-10-29 | 2021-10-29 |
| Coaxial Cable | Huber & Suhner | 106A | SSG012455 | 2021-01-05 | 2022-01-05 |
| Coaxial Cable | Huber & Suhner | 106A | SSG012711 | 2021-01-05 | 2022-01-05 |
| Coaxial Cable | Huber & Suhner | 104PEA | SSG012041 | 2021-01-05 | 2022-01-05 |
| Coaxial Cable | Huber & Suhner | ST18/Nm/Nm/36 | SSG012785 | 2021-01-06 | 2022-01-06 |
| Coaxial Cable | Micro-Coax | UFA 210B-1-1500-504504 | SSG012376 | 2021-01-06 | 2022-01-06 |
| Pre-Amplifier | Hp | 8447D | LAVE04346 | 2020-09-10 | 2021-09-10 |
| Pre-Amplifier | BNR | LNA | SSG012360 | 2020-11-16 | 2021-11-16 |
| Power Supply | Hewlett Packard | 6216A | SSG013063 | not required | not required |
| N/A: No applicable O/P Mon – Output monitored with Calibrated Equipment | | | | | |



3.2 MEASUREMENT UNCERTAINTY

For a 95% confidence level, the measurement uncertainties for defined systems are:

| Test Discipline | Frequency / Parameter | MU |
|-------------------------------------|----------------------------|--------------|
| Conducted Maximum Peak Output Power | 30 MHz to 20 GHz Amplitude | ± 0.1 dB |
| Conducted Emissions | 30 MHz to 20 GHz Amplitude | ± 2.3 dB |
| Frequency Stability | 30 MHz to 2 GHz | ± 5.0 Hz |
| Occupied Bandwidth | Up to 20 MHz Bandwidth | ± 1.1 Hz |
| Band Edge | 30 MHz to 20 GHz Amplitude | ± 2.3 dB |



SECTION 5

ACCREDITATION, DISCLAIMERS AND COPYRIGHT



4.1 ACCREDITATION, DISCLAIMERS AND COPYRIGHT



Testing Laboratory
Certificate #2955.19

This report relates only to the actual item/items tested.

This report does not imply product endorsement by any government, accreditation agency, or TÜV SÜD Canada Inc.

Opinions or interpretations expressed in this report, if any, are outside the scope of TÜV SÜD Canada Inc. accreditations. Any opinions expressed do not necessarily reflect the opinions of TÜV SÜD Canada Inc., unless otherwise stated.

This report relates only to the actual item/items tested.

© 2021 TÜV SÜD