

# RF Report On



Add value.  
Inspire trust.

FCC Testing of the Octasic Portable MIMO System in accordance with  
FCC CFR 47 Part 2, and [FCC CFR 47 Part 24E](#)

COMMERCIAL-IN-CONFIDENCE

FCC: 2AQSOCBRSYS4450

PREPARED BY

Handwritten signature of Jose Martinez.

Jose Martinez

APPROVED BY

Handwritten signature of Scott Drysdale.

Scott Drysdale

DATED

Nov. 9, 21

9-Nov-21

Page 1 of 59

Report Issued:  
11/9/2021

Report File #:  
TR-7169009211H-  
CBRSYS4450-  
Band2and25\_FCC-Issue -03



Testing Laboratory  
Certificate #2955.19



## Table of Contents

<b>1</b>	<b>SECTION 1: REPORT INFORMATION</b>	<b>3</b>
1.1	Report Details	4
1.2	Brief Summary of Results	5
1.3	Product Information	6
<b>1.3.1</b>	<b>Technical Description</b>	<b>6</b>
1.3.1.1	The Transmission in the Band 2 and 25	6
<b>1.3.2</b>	<b>Configuration Description</b>	<b>7</b>
1.4	Declaration of Build Status	8
1.5	General Test Setup	10
1.6	Test Conditions	11
1.7	Deviation From The Standard	11
1.8	Modification Record	11
1.9	TEST FACILITY	11
<b>2</b>	<b>SECTION 2: TEST DETAILS</b>	<b>12</b>
2.1	Maximum Peak Output Power and Peak to Average Ratio - Conducted	13
<b>2.1.1</b>	<b>Specification Reference</b>	<b>13</b>
<b>2.1.2</b>	<b>Date of Test and Modification State</b>	<b>13</b>
<b>2.1.3</b>	<b>Test Equipment Used</b>	<b>13</b>
<b>2.1.4</b>	<b>Environmental Conditions</b>	<b>13</b>
<b>2.1.6</b>	<b>Test Results</b>	<b>14</b>
2.1.6.1	Bottom/Top Channel – 1932.5MHz	14
2.1.6.1.1	Worst Case – Port 1B	15
2.1.6.2	Bottom/Top Channel: 1960.0MHz	16
2.1.6.2.1	Worst Case – Port 1B	17
2.1.6.3	Bottom/Top Channel: 1962.5 MHz	18
2.1.6.3.1	Worst Case – Port 1A	19
2.1.6.4	Bottom/Top Channel: 1987.5 MHz	20
2.1.6.4.1	Worst Case – Port 1B	21
2.1.6.5	Bottom/Top Channel: 1992.5MHz	22
2.1.6.5.1	Worst Case – Port 1A	23
2.2	Occupied Bandwidth	24
<b>2.2.1</b>	<b>Specification Reference</b>	<b>24</b>
<b>2.2.2</b>	<b>Date of Test and Modification State</b>	<b>24</b>
<b>2.2.3</b>	<b>Test Equipment Used</b>	<b>24</b>
<b>2.2.4</b>	<b>Environmental Conditions</b>	<b>24</b>
<b>2.2.6</b>	<b>Test Results</b>	<b>25</b>
2.2.6.1	Bottom/Top Channel – 1932.5 MHz	25
2.2.6.1.1	Worst Case – Port 2B	25
2.2.6.2	Top/Bottom Channel: 1960.0 MHz	26
2.2.6.2.1	Worst Case – Port 1B	26
2.2.6.1	Top/Bottom Channel: 1962.5 MHz	27
2.2.6.1.1	Worst Case – Port 1B	27
2.2.6.1	Top/Bottom Channel: 1987.5 MHz	28
2.2.6.1.1	Worst Case – Port 2A	28
2.2.6.1	Top Channel – 1992.5 MHz	29
2.2.6.1.1	Worst Case – Port 1A	29
2.3	Band Edge	30
<b>2.3.1</b>	<b>Specification Reference</b>	<b>30</b>
<b>2.3.2</b>	<b>Date of Test and Modification State</b>	<b>30</b>
<b>2.3.3</b>	<b>Test Equipment Used</b>	<b>30</b>
<b>2.3.4</b>	<b>Environmental Conditions</b>	<b>30</b>
<b>2.3.6</b>	<b>Test Results</b>	<b>31</b>



2.3.6.1	Bottom/Top Channel – 1932.5 MHz .....	31
2.3.6.1.1	Worst Case – Port 1B .....	31
2.3.6.1	Bottom/Top Channel – 1960 MHz .....	33
2.3.6.1.1	Worst Case – Port 1B .....	33
2.3.6.1	Bottom/Top Channel – 1962.5 MHz .....	35
2.3.6.1.1	Worst Case – Port 1B .....	35
2.3.6.1	Bottom/Top Channel – 1987.5 MHz .....	37
2.3.6.1.1	Worst Case – Port 1B .....	37
2.3.6.2	Top Channel: 1992.5MHz .....	39
2.3.6.2.1	Worst Case – Port 2B .....	39
2.4	Transceiver Spurious Emissions .....	41
2.4.1	Specification Reference .....	41
2.4.2	Date of Test and Modification State .....	41
2.4.3	Test Equipment Used .....	41
2.4.4	Environmental Conditions .....	41
2.4.6	Test Results .....	42
2.4.6.1.1	Worst Case – Port 1A .....	42
2.5	Frequency Stability .....	47
2.5.1	Specification Reference .....	47
2.5.2	Date of Test and Modification State .....	47
2.5.3	Test Equipment Used .....	47
2.5.4	Environmental Conditions .....	47
2.5.6	Test Results .....	47
2.5.6.1.1	Worst Case – Port 1A .....	47
2.6	Field Strength .....	48
2.6.1	Specification Reference .....	48
2.6.2	Date of Test and Modification State .....	48
2.6.3	Test Equipment Used .....	48
2.6.4	Environmental Conditions .....	48
2.6.6	Test Results .....	49
<b>3</b>	<b>SECTION 3: TEST EQUIPMENT USED .....</b>	<b>54</b>
3.1	Test Equipment Used .....	55
3.2	Measurement Uncertainty .....	56
<b>4</b>	<b>ACCREDITATION, DISCLAIMERS AND COPYRIGHT .....</b>	<b>57</b>
4.1	Accreditation, Disclaimers and Copyright .....	58



## **SECTION 1: REPORT INFORMATION**



## 1.1 REPORT DETAILS

<b>Manufacturer</b>	Octasic inc.
<b>Manufacturer Description</b>	CBRSYS4450
<b>Address</b>	2901 Rachel St. East, Suite 30. Montreal, QC, H1W 4A4
<b>Product Name</b>	Portable MIMO System
<b>Product Number</b>	CBRSYS4450
<b>Serial Number(s)</b>	F-01150
<b>Hardware Version(s)</b>	Version 1
<b>Software Version(s)</b>	BSP CBRBTS-BSP-02.07.03.02-B454
<b>Test Specification/Issue/Date</b>	<a href="#">FCC CFR 47 Part 2: August 16, 2021</a> <a href="#">FCC CFR 47 Part 22: September 1, 2021</a>
<b>Max Antenna Gain</b>	5dBi
<b>Start of Test</b>	June 03, 2021
<b>Finish of Test</b>	November 9 <sup>th</sup> , 2021
<b>Name of Test Personnel(s)</b>	Jose Martinez
<b>Related Document(s)</b>	<a href="#">KDB 971168 D01 v02r02: April 2018</a> <a href="#">KDB 662911 D01 v02r01: October 2013</a>
<b>Test report revision history</b>	<p>2021-09-03. Issue 000. Initial release.</p> <p>2021-09-13. Issue 001. Added:</p> <ul style="list-style-type: none"> <li>- Section 2.3 Bandwidth</li> <li>- Section 2.4 Spurious Emission</li> <li>- Section 2.5 Frequency stability</li> </ul> <p>2021-10-19. Issue 02. Modifications:</p> <ul style="list-style-type: none"> <li>• ISED clauses removed</li> <li>• Section 2.1. Power table arranged properly</li> <li>• Section 2.3.5. Update RBW selection</li> </ul> <p>2021-11-09. Issue 03. Modifications:</p> <ul style="list-style-type: none"> <li>• Section 2.3.5. Update Band edge graphs</li> </ul>



## 1.2 BRIEF SUMMARY OF RESULTS

A summary of results for each configuration, in accordance with FCC CFR 47 Part 2 and [FCC CFR 47 Part 24E](#) as shown below.

Table 1 –Test Summary

Section	FCC CFR 47 Part 2	FCC CFR 47 Part 22	Test Description	Result
2.1	§2.1046	<a href="#">§ 24.232(a)(2)</a>	Maximum Peak Output Power	Pass
2.1	2.1049	<a href="#">§ 24.238</a>	Occupied Bandwidth	Pass
2.2	§2.1051	<a href="#">§ 24.238(a)</a>	Band Edge	Pass
2.3	§2.1051	<a href="#">§ 24.238</a>	Transceiver Spurious Emissions	Pass
2.4	§2.1055	<a href="#">§ 24.235</a>	Frequency Stability	Pass
2.3	-	<a href="#">§ 24.238</a>	Filed Strength Limit	Pass
-	-	-	Receiver Spurious Emissions	<Note 2>
Note 1. No applicable Note 2. Not applicable as the EUT is a transceiver.				



### 1.3 PRODUCT INFORMATION

#### 1.3.1 Technical Description

The EUT is transmitting in the spectrum of Block A (1930 MHz – 1945 MHz), Block B (1950 MHz – 1965 MHz), Block C (1975 MHz – 1990 MHz) and Block F (1990 MHz – 1995 MHz) according to [§24E.229](#). The channel configuration is as follows:

##### 1.3.1.1 The Transmission in the Band 2 and 25

The channel configuration is as follows:

Channels	Frequency (MHz)	Target Power (dBm)	Power Measured (dBm)
Bottom/Top	1932.5	28	27.92 <Note 1>
Bottom/Top	1960.0	28	27.87 <Note 2>
Bottom/Top	1962.5	29	26.73 <Note 3>
Bottom/Top	1987.5	28	27.8 <Note 4>
Top	1992.5	28	27.95 <Note 5>
Note 1. See Table 3 in Section 2.1.6.1 (Port TX1B) Note 2. See Table 4 in Section 2.1.6.1 (Port TX1B) Note 3. See Table 5 in Section 2.1.6.1 (Port TX1A) Note 4. See Table 6 in Section 2.1.6.1 (Port TX1B) Note 5. See Table 7 in Section 2.1.6.1 (Port TX1A)			

A full technical description can be found in the Manufacturer's documentation guide and datasheet CBRSYS4450-User\_Guide.pdf and CBRSYS4450-Datasheet.pdf, respectively.



### 1.3.2 Configuration Description

The EUT supports single mode operation having four transmitting ports (see Figure 3)

TX test cases: Maximum Conducted Output Power, Spurious Emissions at Antenna Terminals ( $\pm 1$  MHz) and Conducted Spurious Emissions, measurements were performed on the four RF Port. The test limits shown are representative of the worst case. All testing was performed with the EUT transmitting at maximum RF power unless as designated setting by client, otherwise stated.

The EUT was powered via a 120V/60Hz power AC/DC Adapter.

#### Channel Configurations:

Table 2 – Channel Configuration

LTE Band	No. Of Carriers	Modulation	Carrier Bandwidth	Carrier Frequency Configuration (MHz)				
				Bottom/Top (MHz)	Bottom/Top (MHz)	Bottom/Top (MHz)	Bottom/Top (MHz)	Bottom/Top (MHz)
2 & 25	1	QPSK	5 MHz	1932.5	1960.0	1962.5	1987.5	1992.5





**1.4 DECLARATION OF BUILD STATUS**

<b>MAIN EUT</b>	
<b>MANUFACTURING DESCRIPTION</b>	CBRSYS4450
<b>MANUFACTURER</b>	Octasic inc.
<b>TYPE</b>	Portable Transportable Amplification Unit (TAU)
<b>PART NUMBER(S)</b>	CBRSYS4450
<b>SERIAL NUMBER(S)</b>	F-01150
<b>HARDWARE VERSION(S)</b>	Version 1
<b>SOFTWARE VERSIONS(S)</b>	CBRBTS-BSP-02.07
<b>TRANSMITTER OPERATING RANGE (Band 5)</b>	1932.5 MHz, 1960 MHz; 1962.5 MHz; 1987.5 MHz; and 1992.5 MHz
<b>RECEIVER OPERATING RANGE(MHz)</b>	663 to 2690
<b>EMISSION DESIGNATOR(S): (i.e. G1D, GXW)</b>	194M
<b>Country of Origin</b>	Bangalore, India
<b>MODULATION TYPES: (i.e. GMSK, QPSK)</b>	QPSK
<b>HIGHEST INTERNALLY GENERATED FREQUENCY</b>	2.7GHz
<b>OUTPUT POWER (W or dBm)</b>	30dBm
<b>FCC ID:</b>	2AQSO CBRSYS4450
<b>TECHNICAL DESCRIPTION (a brief description of the intended use and operation)</b>	The CBRSYS4450 is a base station solution build for the particular needs of application like search and Rescue (SRR), Network in Box (NiB) and Disaster Recovery. It integrates four transceiver cellular base station (BTS) with all necessary RF, GPS and Wi-Fi antennas. The control is through an easy-to-use Android app on a smartphone or table for convenient on-the-go operation

Equipment Under Test (EUT)



Figure 3. Top view of CBRSYS4450

## 1.5 GENERAL TEST SETUP

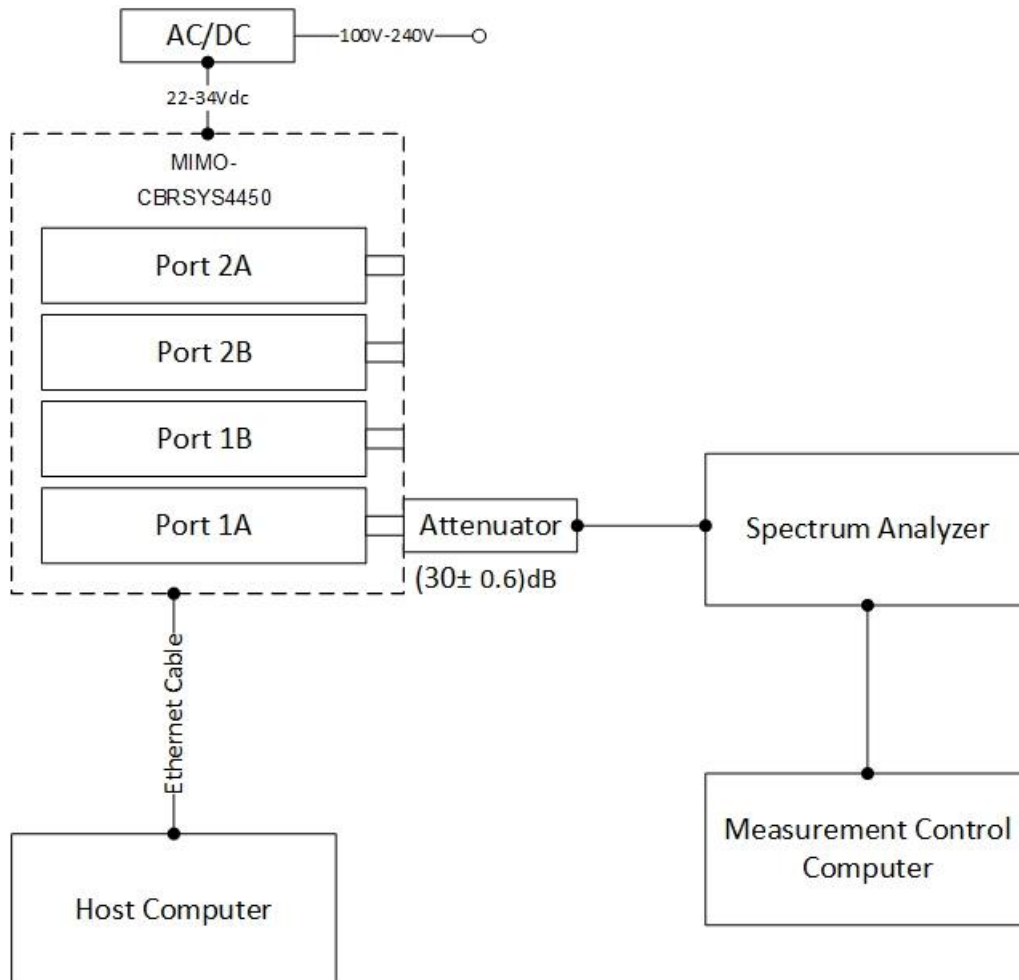

Figure 2. Block Diagram of Conducted Measurement Setup.



## 1.6 TEST CONDITIONS

For all tests the EUT was set up in accordance with the relevant test standard and to represent typical operating conditions. Tests were applied with the EUT situated as described in the Test Method for each Test.

The EUT was powered using the AC/DC adapter.

## 1.7 DEVIATION FROM THE STANDARD

No deviations from the applicable test standards or test plan were made during testing.

## 1.8 MODIFICATION RECORD

No modifications were made to the EUT during testing.

## 1.9 TEST FACILITY

FCC Measurement Facility Registration Number: CA4810

Under our group A2LA Accreditation, TÜV SÜD conducted the following tests at Kanata, Test Laboratory.

Test Name	Name of Test Specialist(s)
Maximum Peak Output Power and Peak to Average Ratio - Conducted	Jose Martinez
Occupied Bandwidth	Jose Martinez
Band Edge	Jose Martinez
Transmitter Spurious Emissions	Jose Martinez
Frequency Stability	Jose Martinez
Field Strength of Spurious Emissions - Radiated	Jose Martinez



## **SECTION 2: TEST DETAILS**



## 2.1 MAXIMUM PEAK OUTPUT POWER AND PEAK TO AVERAGE RATIO - CONDUCTED

### 2.1.1 Specification Reference

FCC CFR 47 Part 2, Clause 2.1046  
FCC CFR 47 Part 24, Clause [§ 24.232\(a\)\(2\)](#)  
662911 D01 Multiple Transmitter Output v02r01:2013  
[412172 D01 Determining ERP and EIRP v01r01](#) :2015-08.

### 2.1.2 Date of Test and Modification State

03 June 2021 - Modification State 0

### 2.1.3 Test Equipment Used

The major items of test equipment used for the above tests are identified in Section 3.1.

### 2.1.4 Environmental Conditions

Ambient Temperature	25.1°C
Relative Humidity	20.4%

### 2.1.5 Test Method

All measurements were made in accordance with FCC KDB 971168 D01, clause 5.2.1 and summed in accordance with FCC KDB 662911 D01. The attenuation value used throughout this report is 30dB ± 0.6dB.

Measurements were performed with a Spectrum Analyser using the Band Power measurement function. The detector was set to RMS with an RBW of at least 1 % of the carrier bandwidth and a VBW of at least 3 times the RBW. The integration bandwidth was configured to be wider than the total bandwidth of the carrier or combinations of carriers, (multi-carrier). Using a sweep time of auto, measurements were performed over 200 samples, with the average measurement recorded.

Due to Average measurements being recorded, an additional Peak to Average power ratio (PAPR) measurement was made. This was achieved using the CCDF function of the Spectrum Analyser with the RBW being set to a value wider than the largest signal being measured – in this case – 20MHz.

The EUT was configured to transmit on maximum power on the configurations defined in the tables below.

The peak to average ratio measurement was performed at the conducted ports of the EUT. The spectrum analyzer's Complementary Cumulative Distribution Function (CCDF) was used, and 0.1% probability value recorded.

The RMS Power and Peak to Average Ratio were measured and recorded with the results being compared with the limits.

Measurements presented are the worst-case of measurements conducted in the four ports: TX1A, TX1B, Tx2A and Tx2B, respectively.



**2.1.6 Test Results**

**2.1.6.1 Bottom/Top Channel – 1932.5MHz**

Maximum Target Output Power: 28 dBm

Table 3 – Max Peak Output Power – Bottom Channel

Antenna	Output Power				Result
	Conducted Average Power		ERP <Note 2>	Limit <Note 3>	
	(dBm)	(mW)	(dBm)	(W)	
TX1A	27.84	608.14	25.22	1640	Pass
TX1B	27.92	619.44	25.28		
TX2A	27.77	598.41	25.16		
TX2B	27.81	603.95	24.94		
Total	33.86	2429.94	-		

Note 1. See worst-case TX1B in Graph 1  
 Note 2. ERP =EIRP -2.15 dB as per [412172 D01](#)  
 Note 3. As per [FCC CFR § 24.232\(a\)\(2\)](#)



### 2.1.6.1.1 Worst Case – Port 1B

Carrier Power Modulation QPSK - Carrier Bandwidth 5.0 MHz – Channel Position: 1932.5 MHz

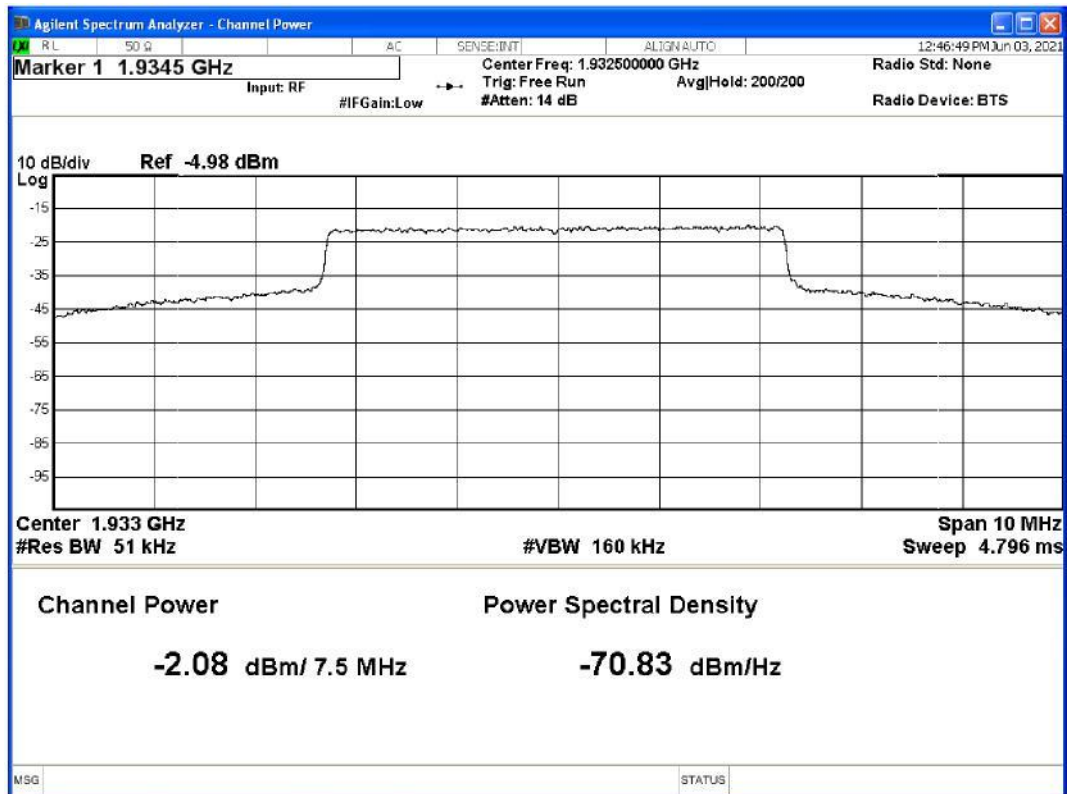

Graph 1: Output Power – Port 1B – Bottom Channel

Calculation:  $30.5\text{dB} - 2.08\text{dBm} = 27.92\text{ dBm}$ .





**2.1.6.2 Bottom/Top Channel: 1960.0MHz**

Maximum Target Output Power: 28 dBm

Table 4 – Max Peak Output Power – Middle Channel

Antenna	Output Power				Result
	Conducted Average Power		ERP <Note 2>	Limit <Note 3>	
	(dBm) <Note 1>	(mW)	(dBm)	(W)	
TX1A	26.57	453.94	23.46	1640	Pass
TX1B	26.26	422.67	23.1		
TX2A	25.99	397.19	22.94		
TX2B	26.21	417.83	23.06		
Total	32.28	1691.63	-		

Note 1. EUT power was reduced to comply with FCC KDB 971168 Clause 6 and ANSI C63.26:2015 Clause 5.7

Note 2. ERP =EIRP -2.15 dB as per [412172 D01](#)

Note 3. As per [FCC CFR § 24.232\(a\)\(2\)](#)



### 2.1.6.2.1 Worst Case – Port 1B

Carrier Power - Modulation QPSK - Carrier Bandwidth 5.0 MHz – Channel Position: 1960.0MHz

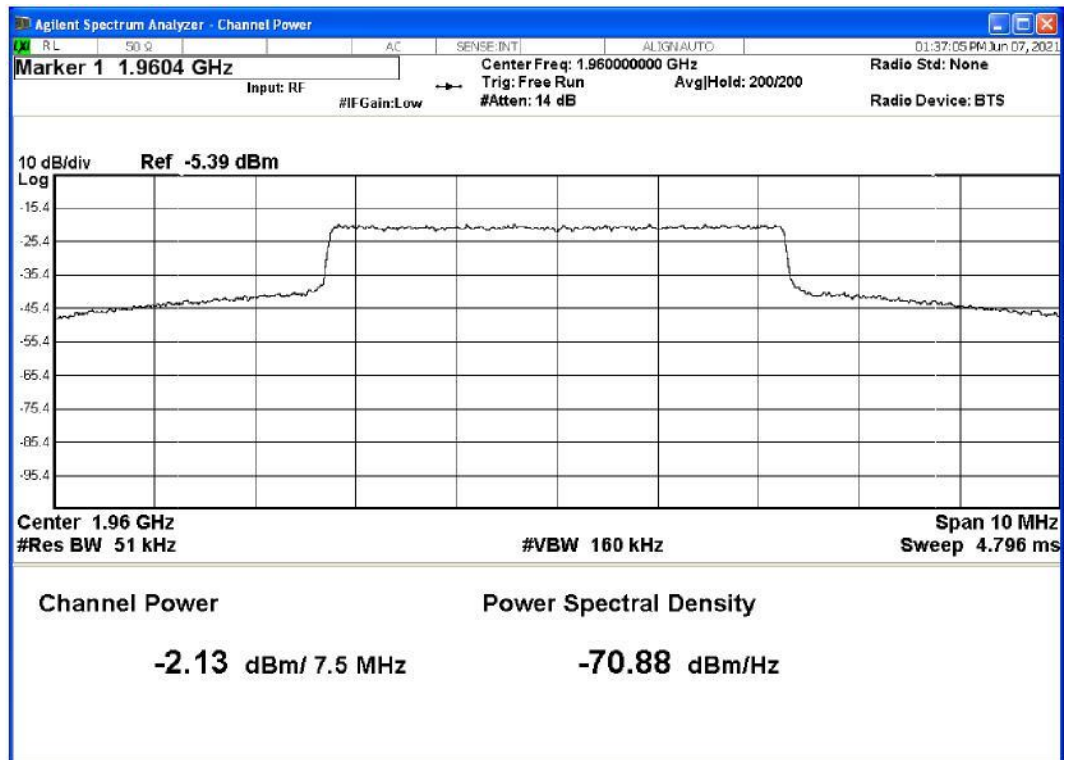

Graph 2: Output Power – Port 2B – Middle Channel

Calculation:  $30 \text{ dB} - 2.13 \text{ dBm} = 27.87 \text{ dBm}$ .



**2.1.6.3 Bottom/Top Channel: 1962.5 MHz**

Maximum Target Output Power: 29 dBm

Table 5 – Max Peak Output Power – Middle Channel

Antenna	Output Power				Result
	Conducted Average Power		ERP <Note 2>	Limit <Note 3>	
	(dBm) <Note 1>	(mW)	(dBm)	(W)	
TX1A	26.73	470.98	23.56	1640	Pass
TX1B	26.61	458.14	23.44		
TX2A	26.02	399.94	23.04		
TX2B	26.26	422.67	23.48		
Total	32.43	1751.73	-		

Note 1. EUT power was reduced to comply with FCC KDB 971168 Clause 6 and ANSI C63.26:2015 Clause 5.7  
 Note 2. ERP =EIRP -2.15 dB as per [412172 D01](#)  
 Note 3. As per [FCC CFR § 24.232\(a\)\(2\)](#)



### 2.1.6.3.1 Worst Case – Port 1A

Carrier Power - Modulation QPSK - Carrier Bandwidth 5.0 MHz – Channel Position: 1962.5 MHz

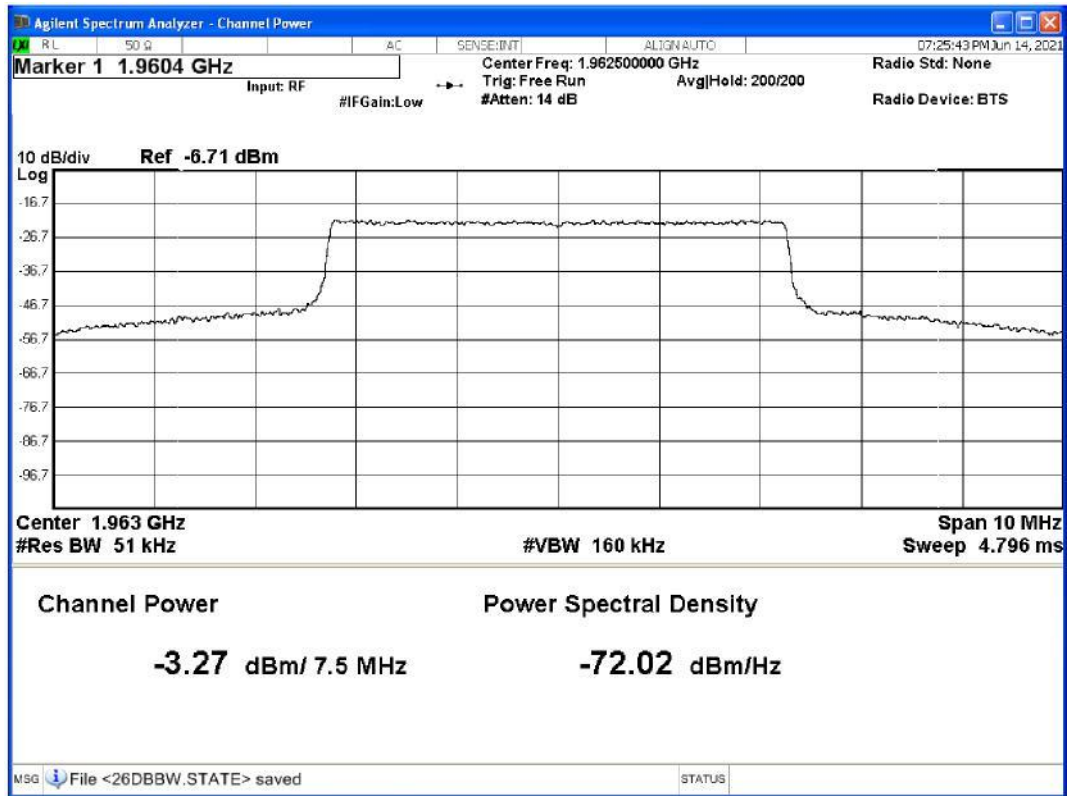

Graph 3: Output Power – Port 1A – Middle Channel

Calculation:  $30 \text{ dB} - 3.27 \text{ dBm} = 26.73 \text{ dBm}$ .



**2.1.6.4 Bottom/Top Channel: 1987.5 MHz**

Maximum Target Output Power: 28 dBm

Table 6 – Max Peak Output Power – Middle Channel

Antenna	Output Power				Result
	Conducted Average Power		ERP <Note 2>	Limit <Note 3>	
	(dBm)	(mW)	(dBm)	(W)	
TX1A	27.58	572.80	24.3	1640	Pass
TX1B	27.8	602.56	24.71		
TX2A	27.75	595.66	25.06		
TX2B	27.77 <Note 1>	598.41	23.62		
Total	33.75	2369.43	-		
Note 1. See worst-case TX2B in Graph 4 Note 2. ERP =EIRP -2.15 dB as per <a href="#">412172 D01</a> Note 3. As per <a href="#">FCC CFR § 24.232(a)(2)</a>					



### 2.1.6.4.1 Worst Case – Port 1B

Carrier Power - Modulation QPSK - Carrier Bandwidth 5.0 MHz – Channel Position: 1962.5 MHz

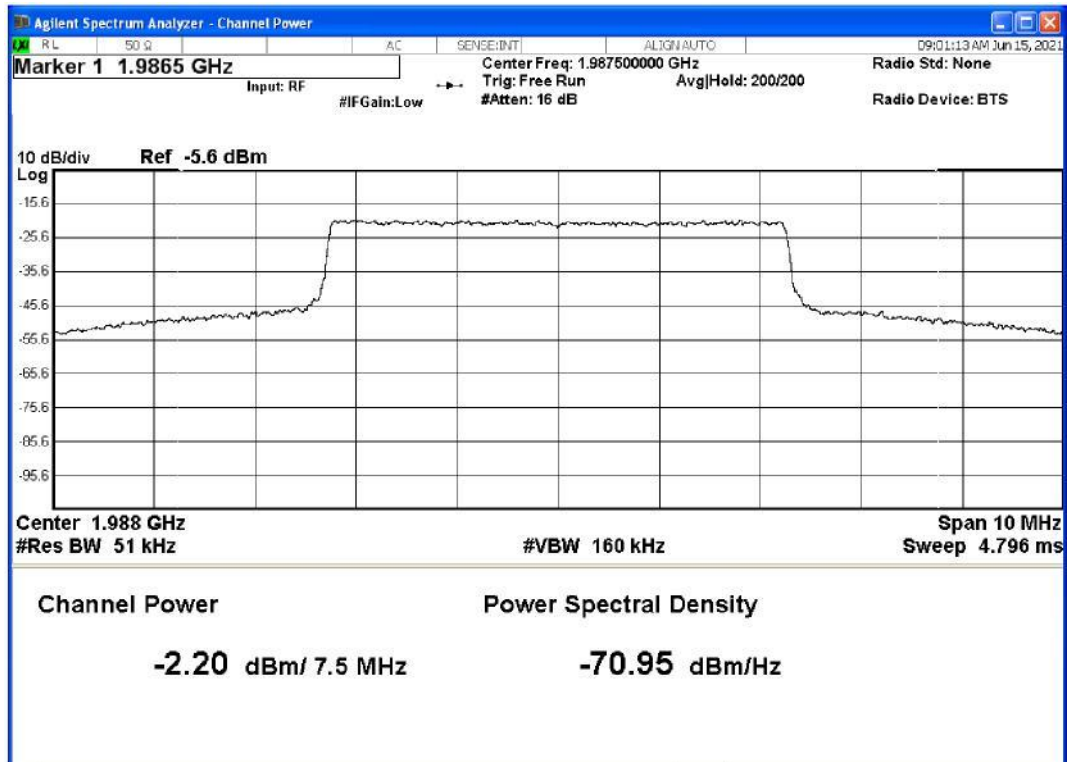

Graph 4: Output Power – Port 1A – Bottom/Top Channel

Calculation:  $30 \text{ dB} - 2.20 \text{ dBm} = 27.80 \text{ dBm}$ .



**2.1.6.5 Bottom/Top Channel: 1992.5MHz**

Maximum Target Output Power: 28 dBm

Table 7 – Max Peak Output Power – Top Channel

Antenna	Output Power				Result
	Conducted Average Power		ERP <Note 2>	Limit <Note 3>	
	(dBm)	(mW)	(dBm)	(W)	
TX1A	27.95 <Note 1>	623.73	24.88	1640	Pass
TX1B	27.7	588.84	25.5		
TX2A	27.76	597.04	24.8		
TX2B	27.67	584.79	24.6		
Total	33.79	2394.40	-		

Note 1. See worst-case TX1A in Graph 5  
 Note 2. ERP =EIRP -2.15 dB as per [412172 D01](#)  
 Note 3. As per [FCC CFR § 24.232\(a\)\(2\)](#)



### 2.1.6.5.1 Worst Case – Port 1A

Carrier Power - Modulation QPSK - Carrier Bandwidth 5.0 MHz – Channel Position: 1992.5MHz

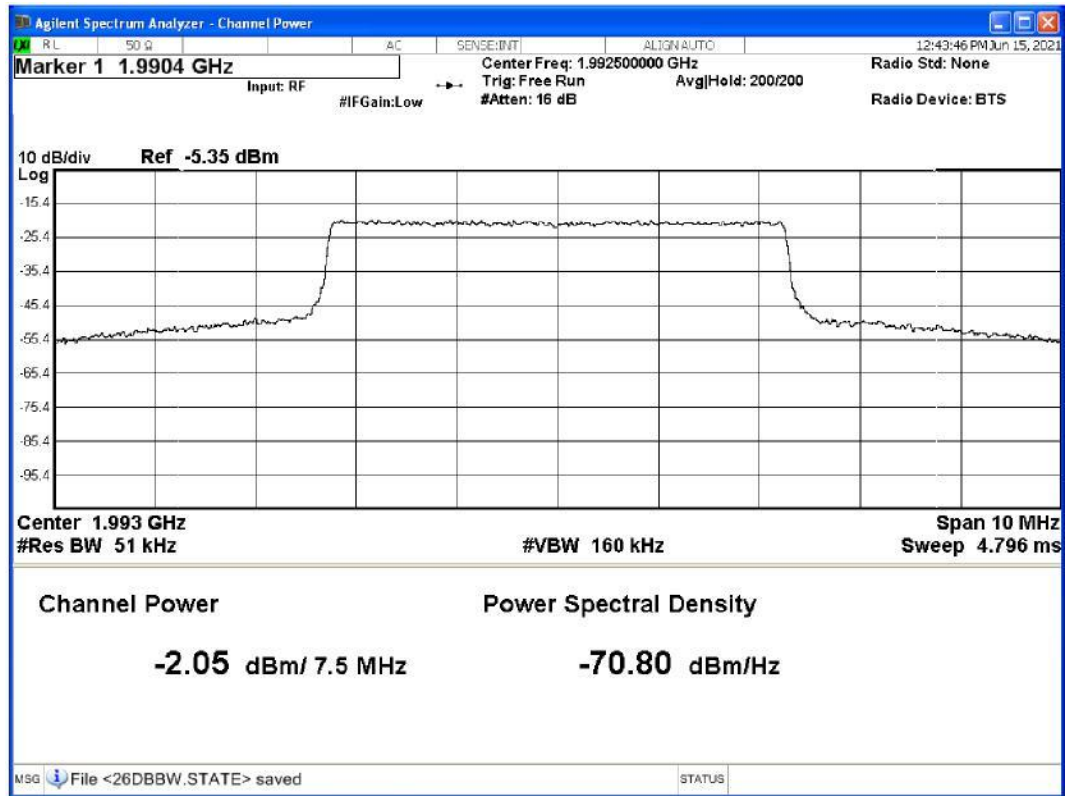

Graph 5: Output Power – Port 1A – Top Channel

Calculation.  $30\text{dB} - 2.05\text{ dBm} = 27.95\text{ dBm}$ .





## 2.2 OCCUPIED BANDWIDTH

### 2.2.1 Specification Reference

FCC CFR 47 Part 2, Clause 2.1049  
FCC CFR 47 Part 24, Clause [§ 24.238](#)

### 2.2.2 Date of Test and Modification State

03 June 2021 - Modification State 0  
07 June 2021 - Modification State 0  
08 June 2021 - Modification State 0  
14 June 2021 - Modification State 0

### 2.2.3 Test Equipment Used

The major items of test equipment used for the above tests are identified in Section 3.1.

### 2.2.4 Environmental Conditions

Ambient Temperature	22.1°C
Relative Humidity	16.4%

### 2.2.5 Test Method

All measurements were made in accordance with FCC KDB 971168 D01.



## 2.2.6 Test Results

Maximum Output Power: 1932.5 MHz (28 dBm); 1960.0 MHz (28 dBm) 1962.5 MHz (29dBm)  
1987.5 MHz (28 dBm) and 1992.5 MHz (28 dBm).

The worst-case scenario of all channels is provided below.

### 2.2.6.1 Bottom/Top Channel – 1932.5 MHz

#### 2.2.6.1.1 Worst Case – Port 2B

Modulation	Carrier Bandwidth	Result (MHz)	
		Channel Bandwidth	
		Occupied Bandwidth	-26 dB Bandwidth
QPSK	5.0 MHz	4.6	9.69

Bandwidth 5.0MHz – Modulation: QPSK – Channel B: 1932.5 MHz

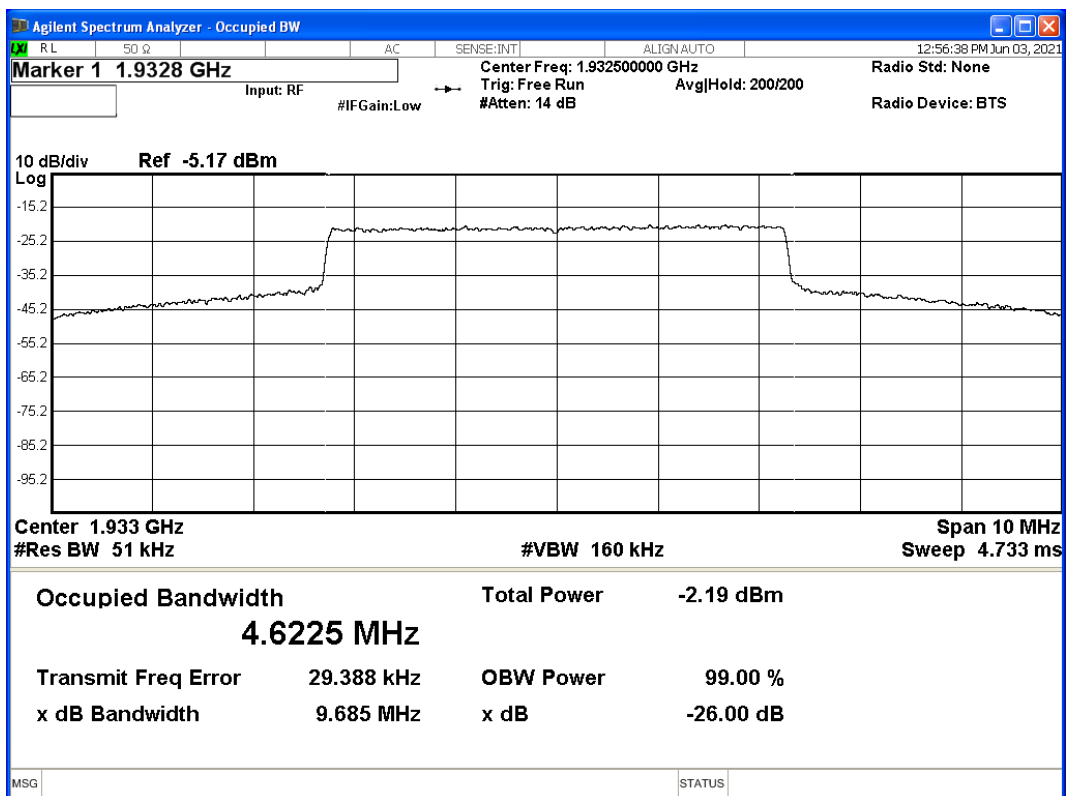



## 2.2.6.2 Top/Bottom Channel: 1960.0 MHz

### 2.2.6.2.1 Worst Case – Port 1B

Modulation	Carrier Bandwidth	Result (MHz)	
		Channel Bandwidth	Occupied Bandwidth
QPSK	5.0 MHz	4.5	4.8

Bandwidth 5.0MHz – Modulation: QPSK – Channel Middle: 1960.0 MHz

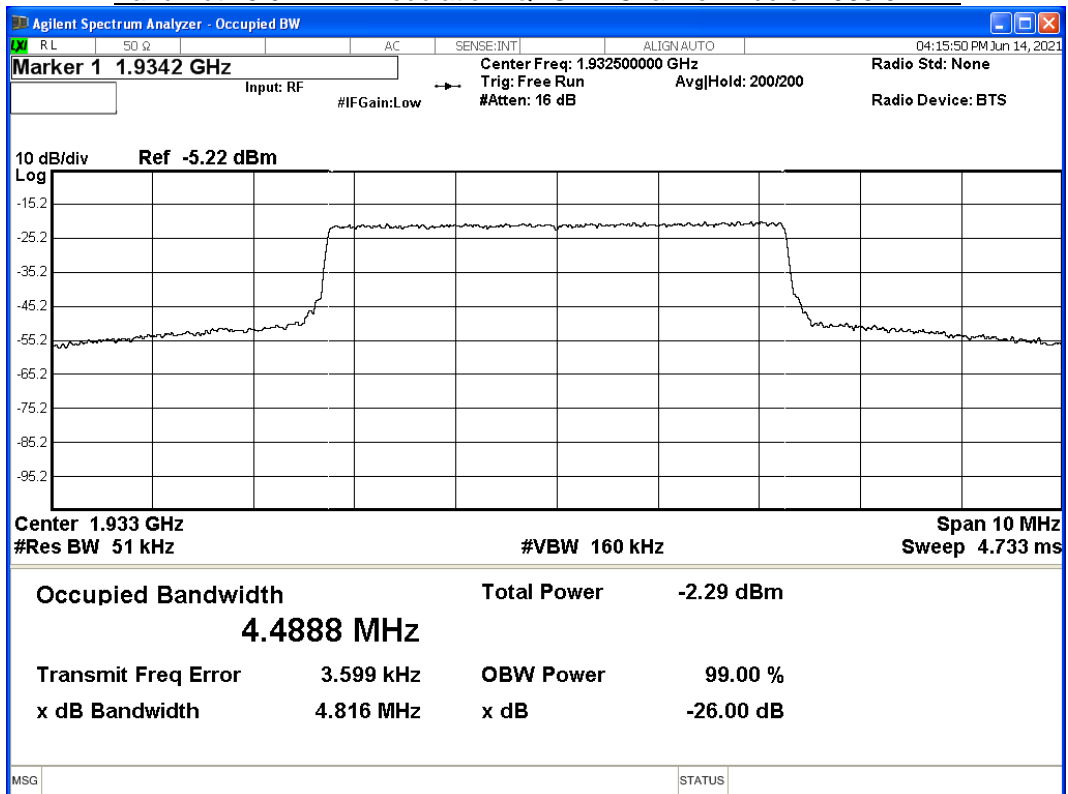



2.2.6.1 Top/Bottom Channel: 1962.5 MHz

2.2.6.1.1 Worst Case – Port 1B

Modulation	Carrier Bandwidth	Result (MHz)	
		Channel Bandwidth	-26 dB Bandwidth
QPSK	5.0 MHz	5/0	9.9

Bandwidth 5.0MHz – Modulation: QPSK – Channel Middle: 1960.0 MHz

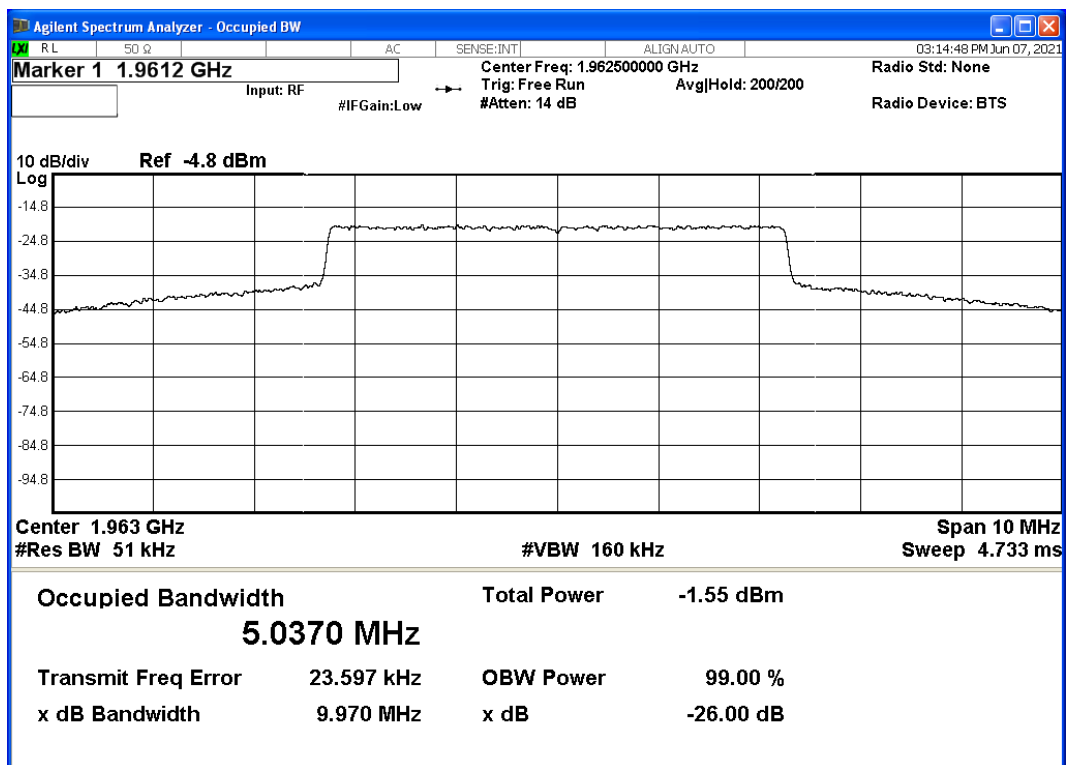



2.2.6.1 Top/Bottom Channel: 1987.5 MHz

2.2.6.1.1 Worst Case – Port 2A

Modulation	Carrier Bandwidth	Result (MHz)	
		Channel Bandwidth	
		Occupied Bandwidth	-26 dB Bandwidth
QPSK	5.0 MHz	4.5	7.9

Bandwidth 5.0MHz – Modulation: QPSK – Channel Middle: 1987.5 MHz

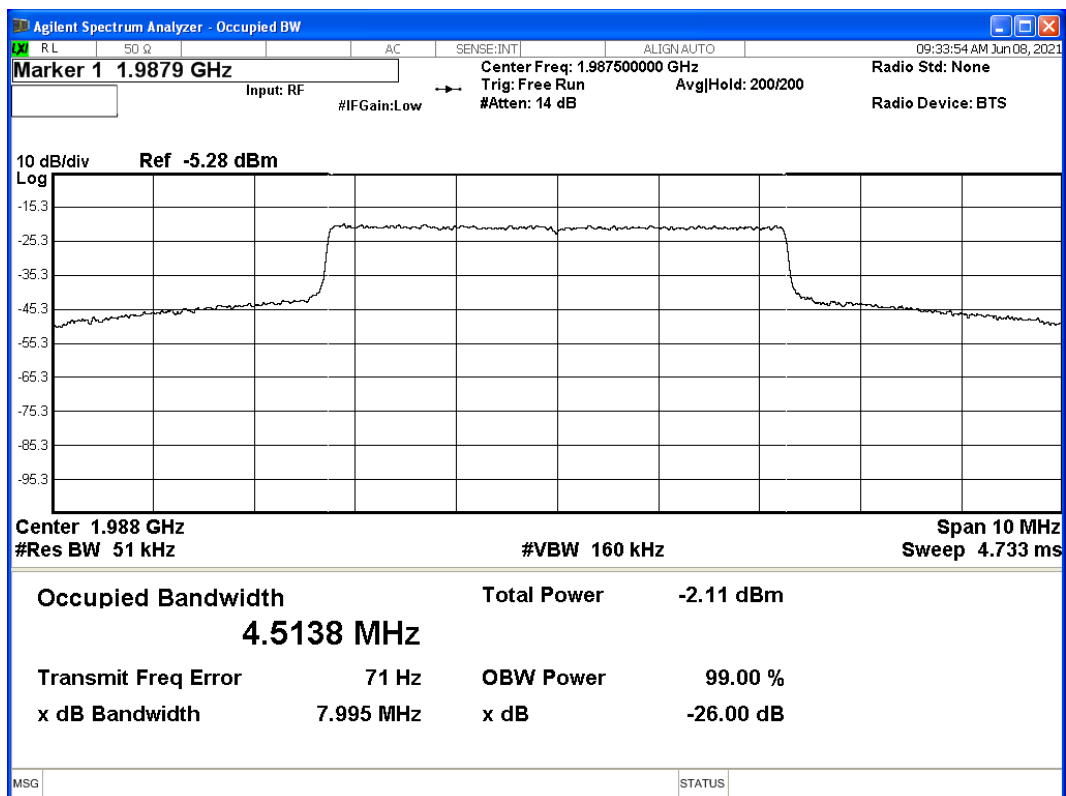



2.2.6.1 Top Channel – 1992.5 MHz

2.2.6.1.1 Worst Case – Port 1A

Modulation	Carrier Bandwidth	Result (MHz)	
		Channel Bandwidth	
QPSK	5.0 MHz	Occupied Bandwidth	-26 dB Bandwidth
		4.5	7.7

Bandwidth 5.0MHz – Modulation: QPSK – Channel Top: 1992.5 MHz

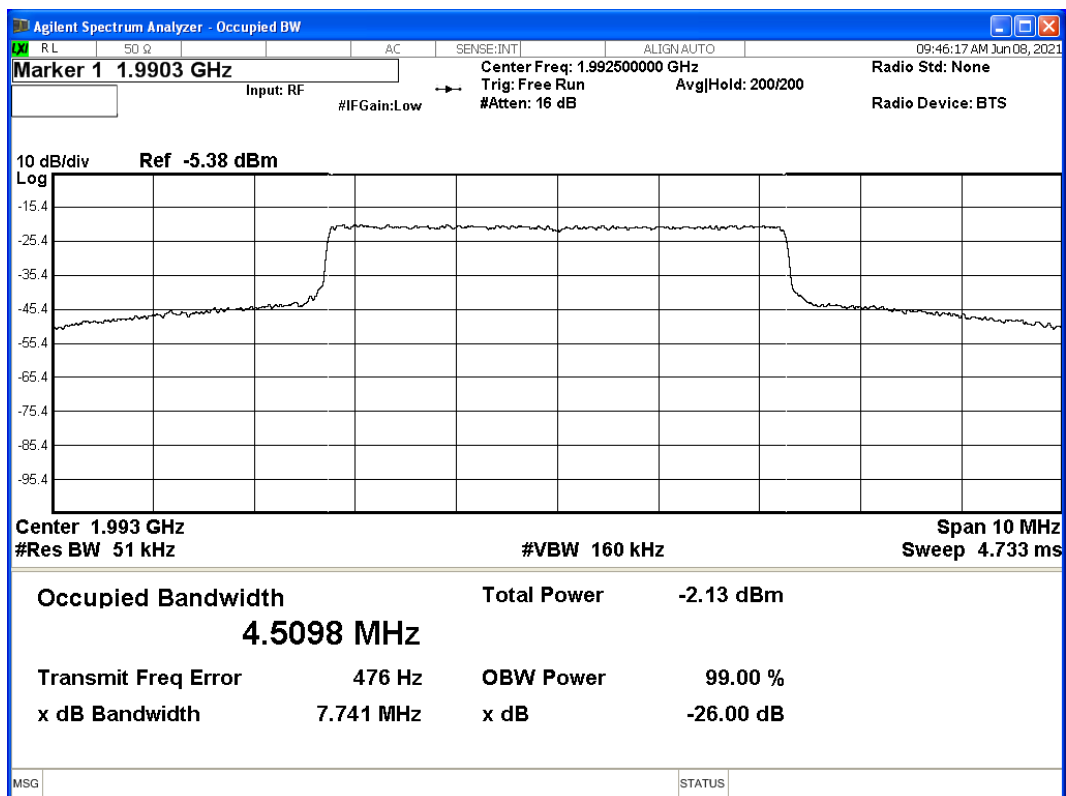



## 2.3 BAND EDGE

### 2.3.1 Specification Reference

FCC CFR 47 Part 2, Clause 2.1051  
FCC CFR 47 Part 24, [§ 24.238\(a\)](#)

### 2.3.2 Date of Test and Modification State

04 September 2021 - Modification State 0

### 2.3.3 Test Equipment Used

The major items of test equipment used for the above tests are identified in Section 3.1.

### 2.3.4 Environmental Conditions

Ambient Temperature	24.1°C
Relative Humidity	25.4%

### 2.3.5 Test Method

All measurements were made in accordance with FCC KDB 971168 D01, clause 6. The EUT was connected to a Spectrum Analyser via an attenuator. The path loss between the EUT and the Spectrum Analyser was measured using a Network Analyser. The measured path loss was entered as a Reference Level Offset in the Spectrum Analyser. The Spectrum Analyser RBW was adjusted to be at least 1% of the measured 26dB Bandwidth. Using an RMS detector, the frequency spectrum up to 1MHz away from the Band Edge was Investigated.

The Spectrum Analyser RBW was adjusted to be at least 1% of the measured 26dB Bandwidth. Using an RMS detector, the frequency spectrum up to 1MHz from the band edge was investigated. The worst-case path loss in the measured ranges was entered as a reference level offset. Over the measured ranges, the RBW was set to 10kHz, however the band power function of the SA was used with an integration of 50kHz bandwidth. All measurement results are specified as average with an RMS detector being used in conjunction with a trace setting of Max Hold or clear write if representative. Measurements were performed in configurations of the EUT as reported below.

The EUT has four transmit ports, testing was performed in all ports with a test limit of:

$$43+10x\log_{10}(P) +10x\text{Log}_{10}(4) = -19 \text{ dBm.}$$



### 2.3.6 Test Results

Maximum Output Power: Bottom 30 dBm; Middle 30 dBm and Top 30 dBm. The band edges of middle channels were determined and only the worst scenario is provided.

#### 2.3.6.1 Bottom/Top Channel – 1932.5 MHz

##### 2.3.6.1.1 Worst Case – Port 1B

Maximum Target output Power: 28 dBm

Modulation	Carrier Bandwidth	Band Edge (MHz)			Band Power	
		Channel Position:	Lower Band	Upper Band	100kHz	1MHz
LTE	5.0 MHz	Bottom	1930	1945	-26.36	-19.25
		Top			-57.75	-48.22

Modulation QPSK - Carrier Bandwidth 5.0 MHz – Bottom – Channel Position: 1932.5 MHz  
(Band Power 50kHz and 1MHz)

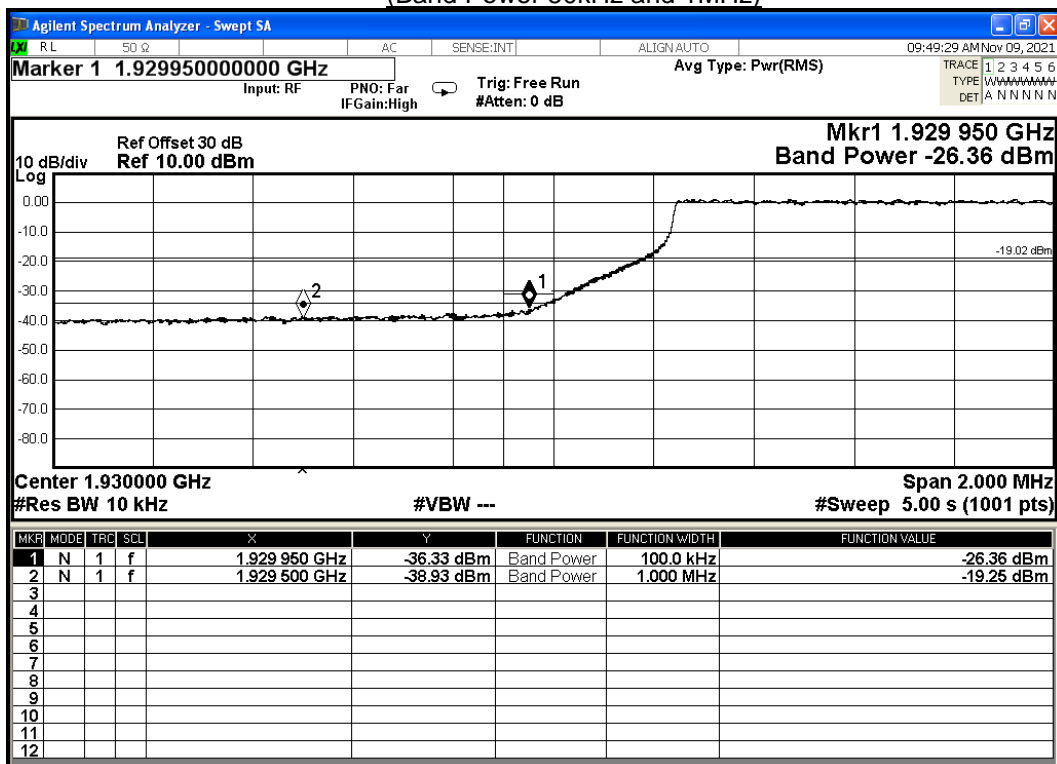





Modulation QPSK - Carrier Bandwidth 5.0 MHz – Top – Channel Position: 1932.5 MHz (Band Power 50kHz and 1MHz)

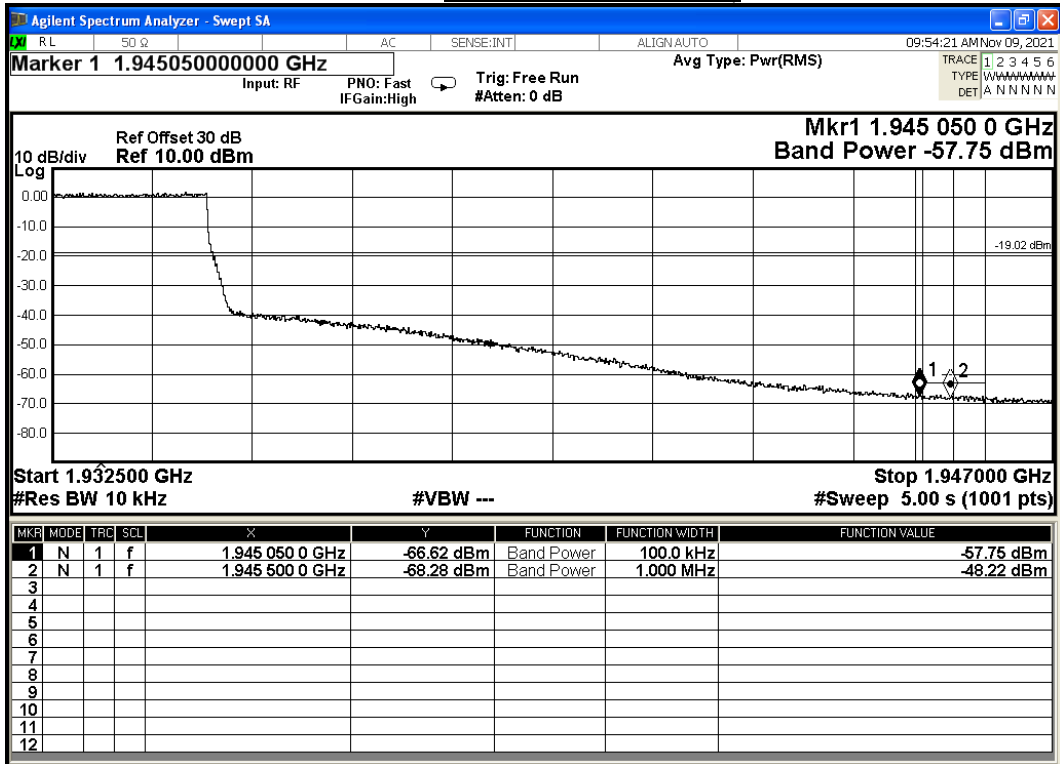



### 2.3.6.1 Bottom/Top Channel – 1960 MHz

#### 2.3.6.1.1 Worst Case – Port 1B

Maximum Target output Power: 28 dBm

Modulation	Carrier Bandwidth	Band Edge (MHz)			Band Power	
		Channel Position:	Lower Band	Upper Band	100kHz	1MHz
LTE	5.0 MHz	Bottom	1950	1965	-48.18	-39.32
		Top			-28.28	-19.95

Modulation QPSK - Carrier Bandwidth 5.0 MHz – Bottom – Channel Position: 1960 MHz (Band Power 50kHz and 1MHz)

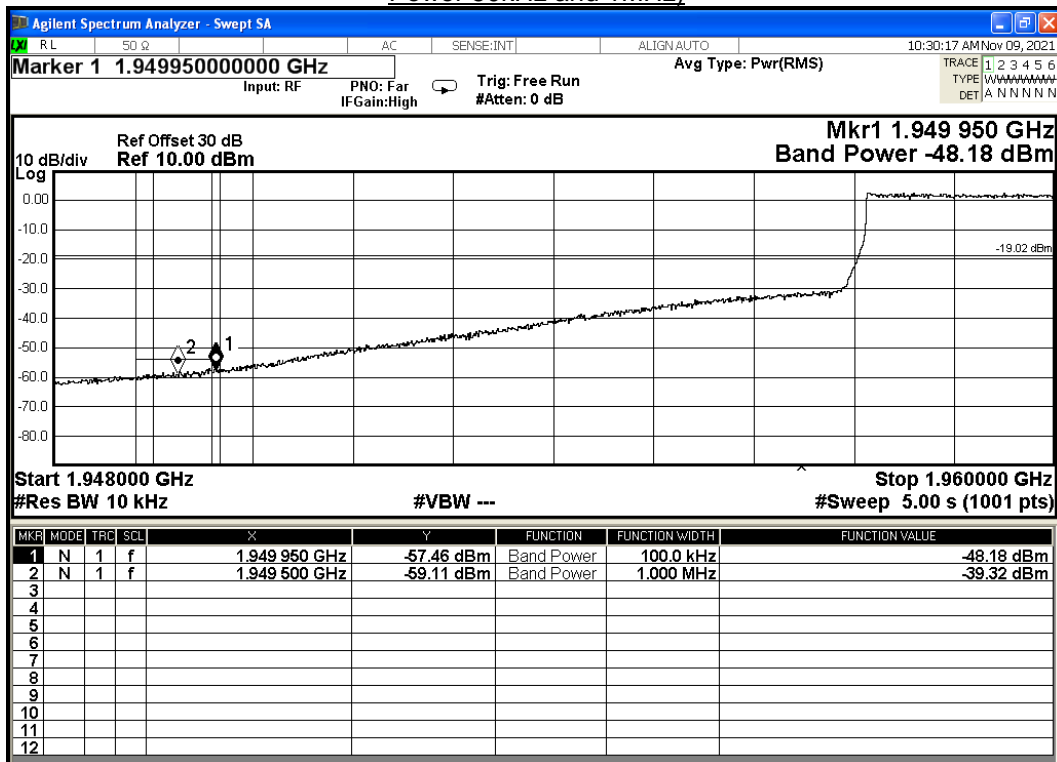

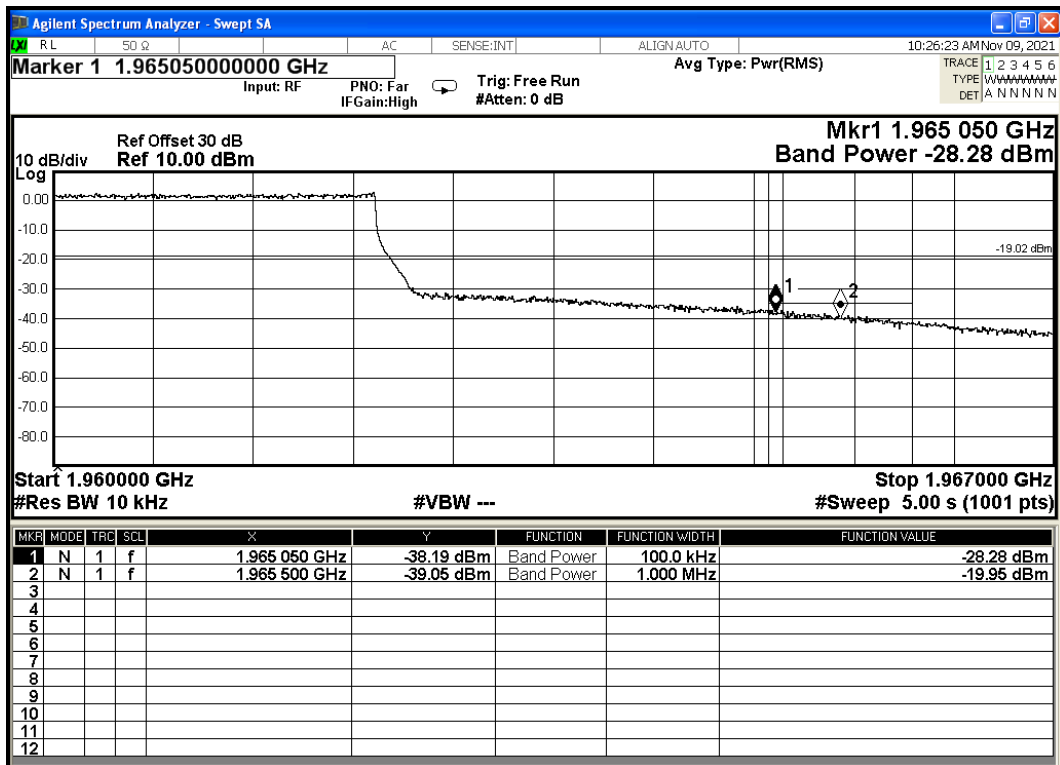



**2.3.6.1 Bottom/Top Channel – 1962.5 MHz**

**2.3.6.1.1 Worst Case – Port 1B**

Maximum Target output Power: 29 dBm

Modulation	Carrier Bandwidth	Band Edge (MHz)			Band Power	
		Channel Position:	Lower Band	Upper Band	100kHz	1MHz
LTE	5.0 MHz	Bottom	1950	1965	-57.53	-47.90
		Top			-26.50	-19.64

Modulation QPSK - Carrier Bandwidth 5.0 MHz – Bottom – Channel Position: 1962.5 MHz  
(Band Power 50KHz and 1MHz)

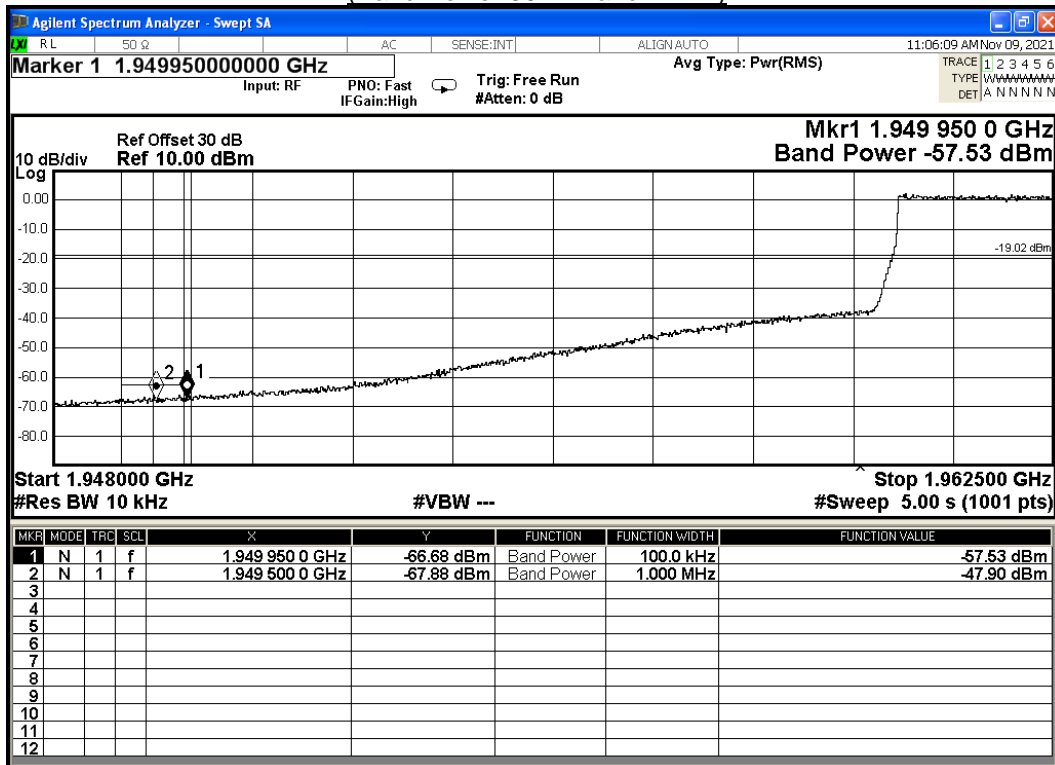



Modulation QPSK - Carrier Bandwidth 5.0 MHz – Top – Channel Position: 1962.5 MHz (Band Power 50KHz and 1MHz)

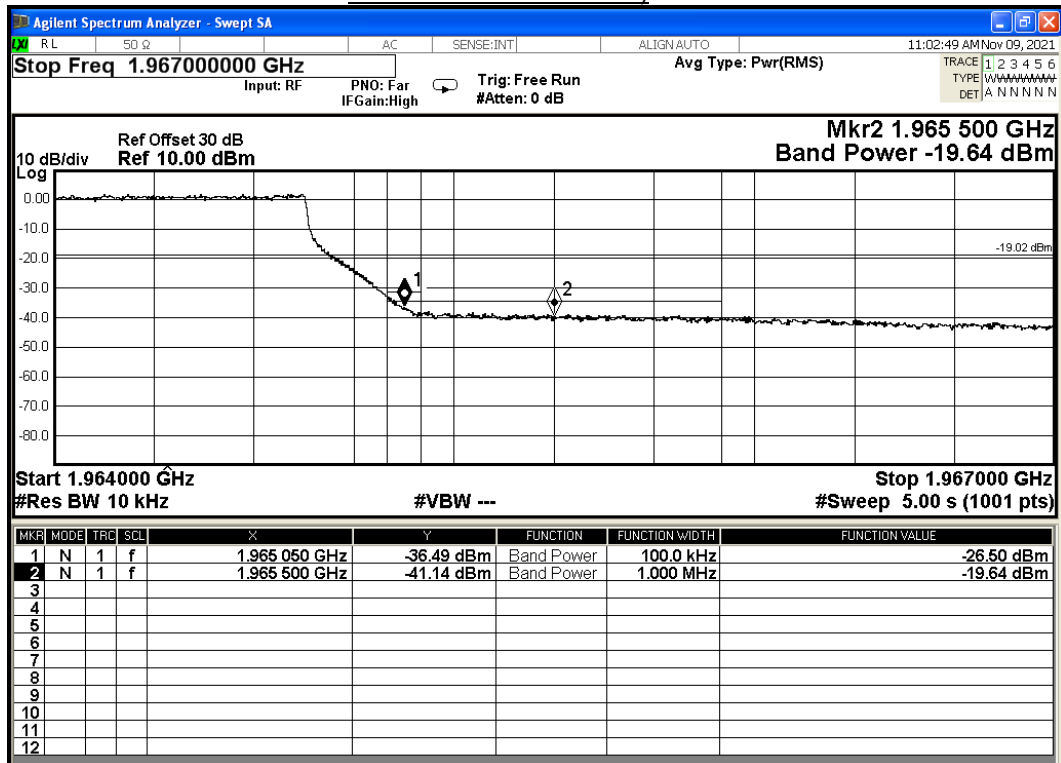



### 2.3.6.1 Bottom/Top Channel – 1987.5 MHz

#### 2.3.6.1.1 Worst Case – Port 1B

Maximum Target output Power: 28 dBm

Modulation	Carrier Bandwidth	Band Edge (MHz)			Band Power	
		Channel Position:	Lower Band	Upper Band	100kHz	1MHz
LTE	5.0 MHz	Bottom	1975	1990	-57.57	-47.
		Top			-26.62	-19.73

Modulation QPSK - Carrier Bandwidth 5.0 MHz – Bottom – Channel Position: 1987.5 MHz  
(Band Power 50kHz and 1MHz)

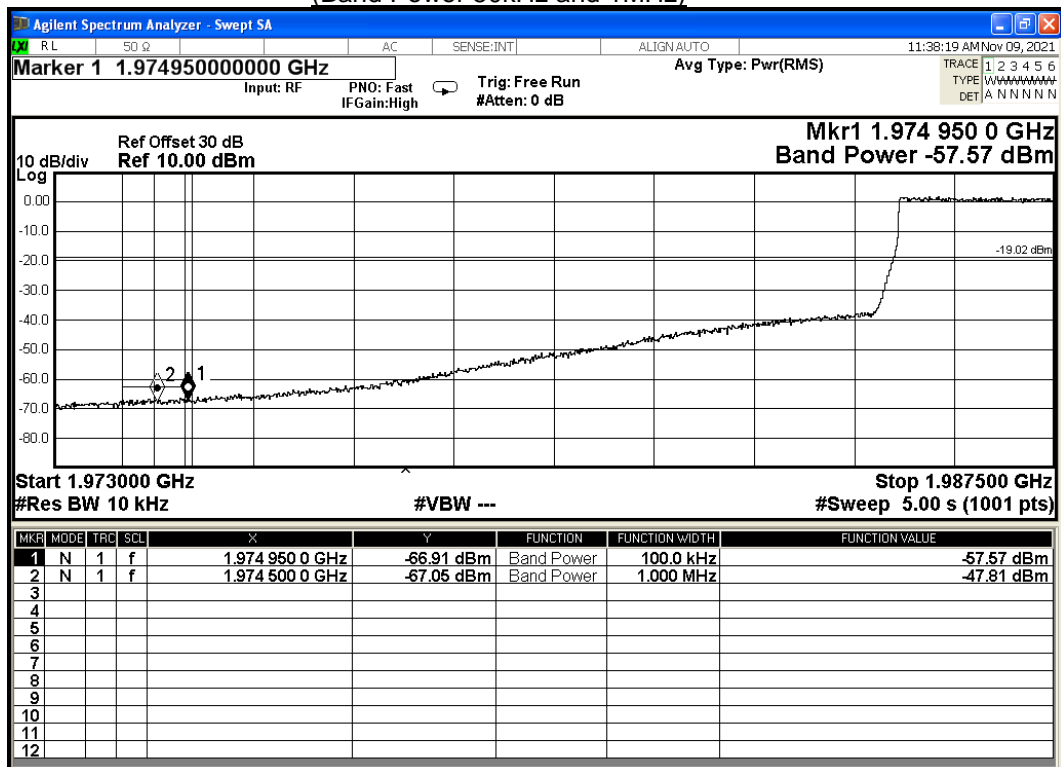



Modulation QPSK - Carrier Bandwidth 5.0 MHz – Top – Channel Position: 1987.5 MHz (Band Power 50kHz and 1MHz)

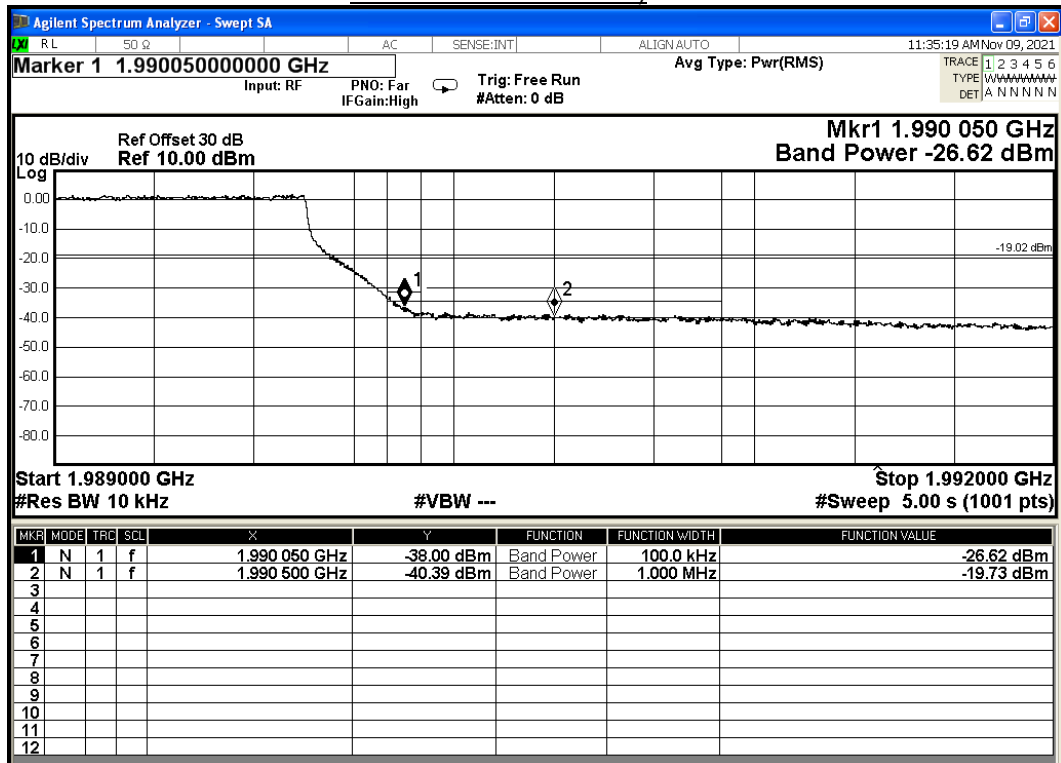



### 2.3.6.2 Bottom/Top Channel: 1992.5MHz

Maximum Target output Power: 28 dBm

#### 2.3.6.2.1 Worst Case – Port 2B

Modulation	Carrier Bandwidth	Band Edge (MHz)			Band Power	
		Channel Position:	Lower Band	Upper Band	100kHz	1MHz
LTE	5.0 MHz	Bottom	1990	1995	-25.65	-20.07
		Top			-26.62	-19.73

Modulation QPSK - Carrier Bandwidth 5.0 MHz – Bottom – Channel Position: 1992.5MHz (Band Power 50kHz and 1MHz)

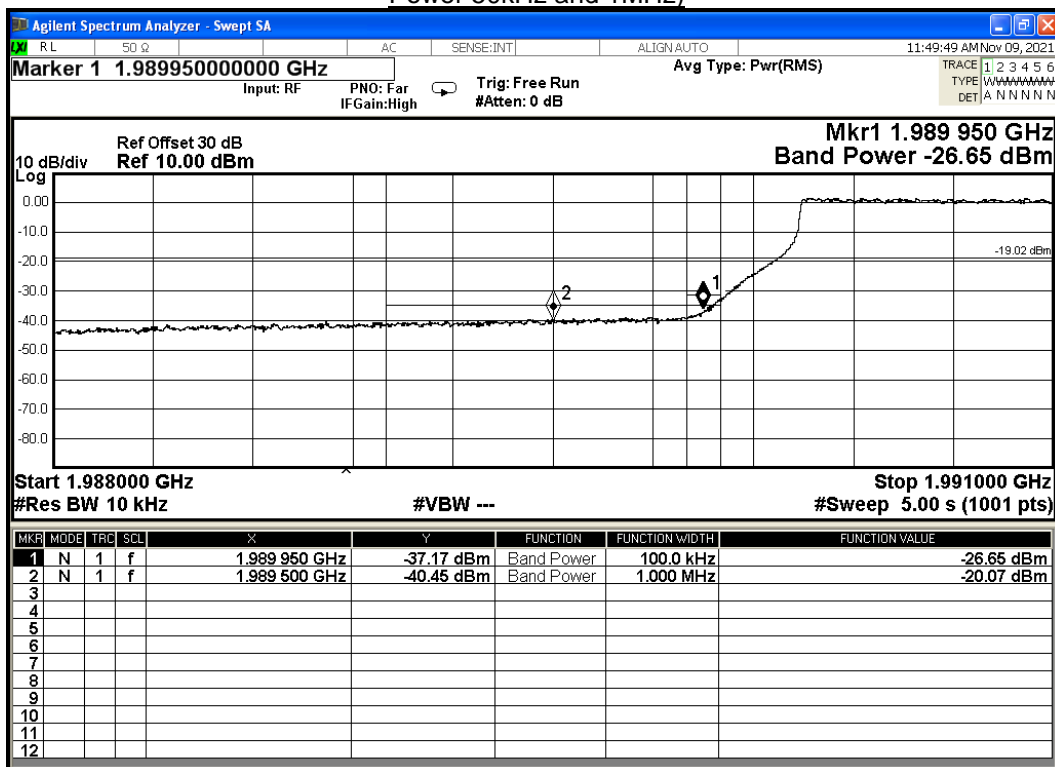





Modulation QPSK - Carrier Bandwidth 5.0 MHz – Top – Channel Position: 1992.5MHz (Band Power 50kHz and 1MHz)

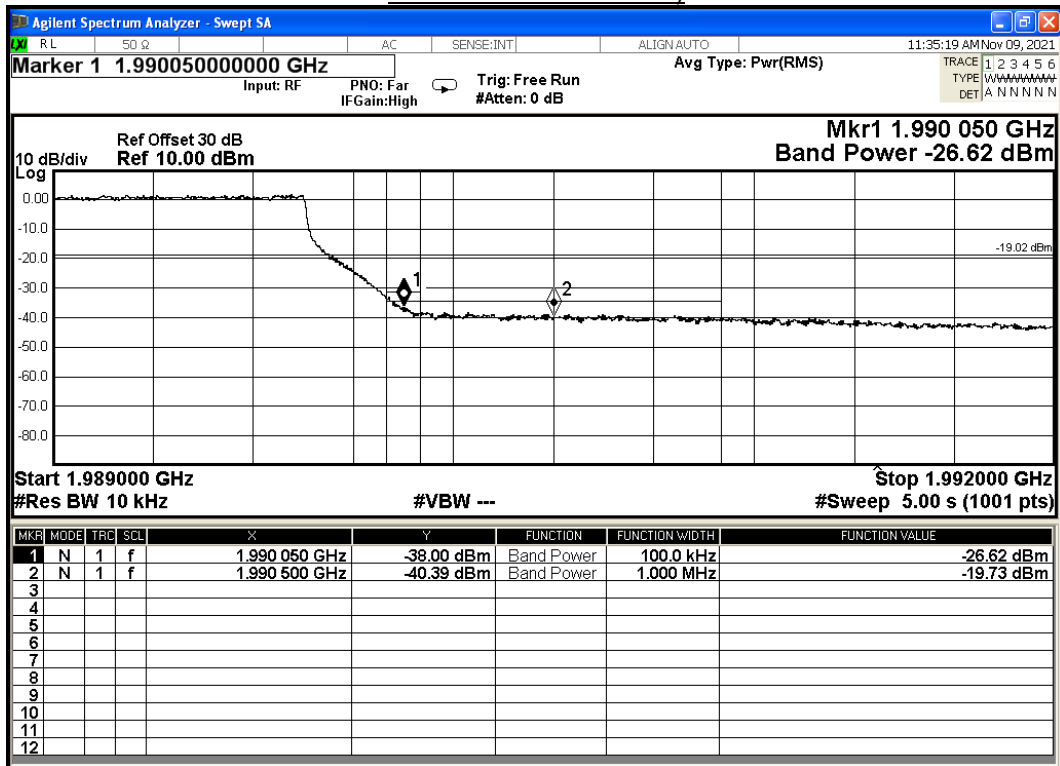



## 2.4 TRANSCEIVER SPURIOUS EMISSIONS

### 2.4.1 Specification Reference

FCC CFR 47 Part 2, Clause 2.1051  
FCC CFR 47 Part 24, Clause [§ 24.238](#)

### 2.4.2 Date of Test and Modification State

15 July 2021- Modification State 0  
09 August 2021- Modification State 0  
10 August 2021- Modification State 0

### 2.4.3 Test Equipment Used

The major items of test equipment used for the above tests are identified in Section 3.1.

### 2.4.4 Environmental Conditions

Ambient Temperature	25.1°C
Relative Humidity	16.4%

### 2.4.5 Test Method

All measurements were made in accordance with FCC KDB 971168 D01.

All measurements were made in accordance with FCC KDB 971168 D01 Clause 6. The EUT was connected to a Spectrum Analyser via an attenuator and switching box. Prior to testing, a Network Analyser was used to calibrate the path loss between the EUT and the Spectrum Analyser. The worst-case path loss in the measured ranges was entered as a reference level offset. Over the measured ranges, the RBW was set to 1MHz with a VBW of 3MHz. All measurement results are specified as average with an RMS detector being used in conjunction with a trace setting of Max Hold. Measurements were performed in configurations of the EUT as reported below. Testing was performed on this port with a test limit of  $43+10\log_{10}(P) +10\text{Log}_{10}(4) = -19 \text{ dBm}$ .



## 2.4.6 Test Results

Range Frequency	Limit (dBm)	Result
9kHz to 1GHz	-19	Pass
1GHz to 5G	-19	Pass
5G to 26GHz	-19	Pass
26GHz to 40GHz	-19	Pass <Note 1>
Note 1. The device was scanned up to 40Ghz with no emission (peak values less than 6Bd from the limit)		

### 2.4.6.1.1 Worst Case – Port 1A

Modulation QPSK - Carrier Bandwidth 5.0 MHz – Range 9kHz to 1GHz

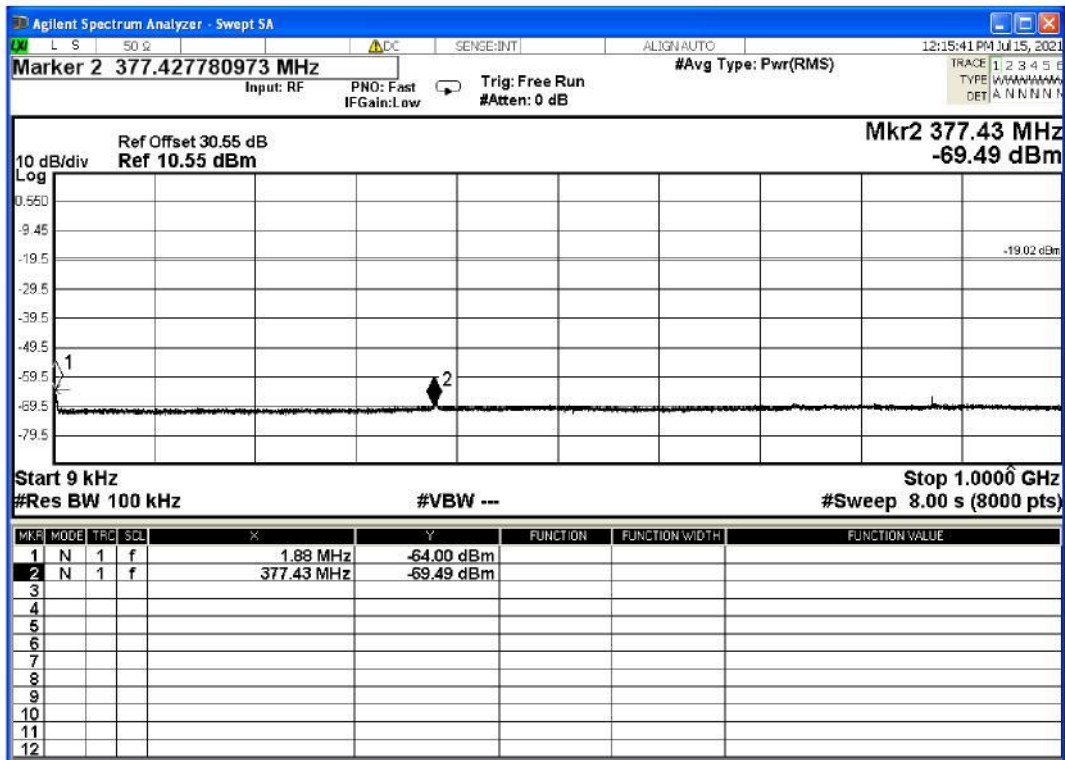



Modulation QPSK - Carrier Bandwidth 5.0 MHz – Range 1GHz to 5GHz: 1932.5 MHz

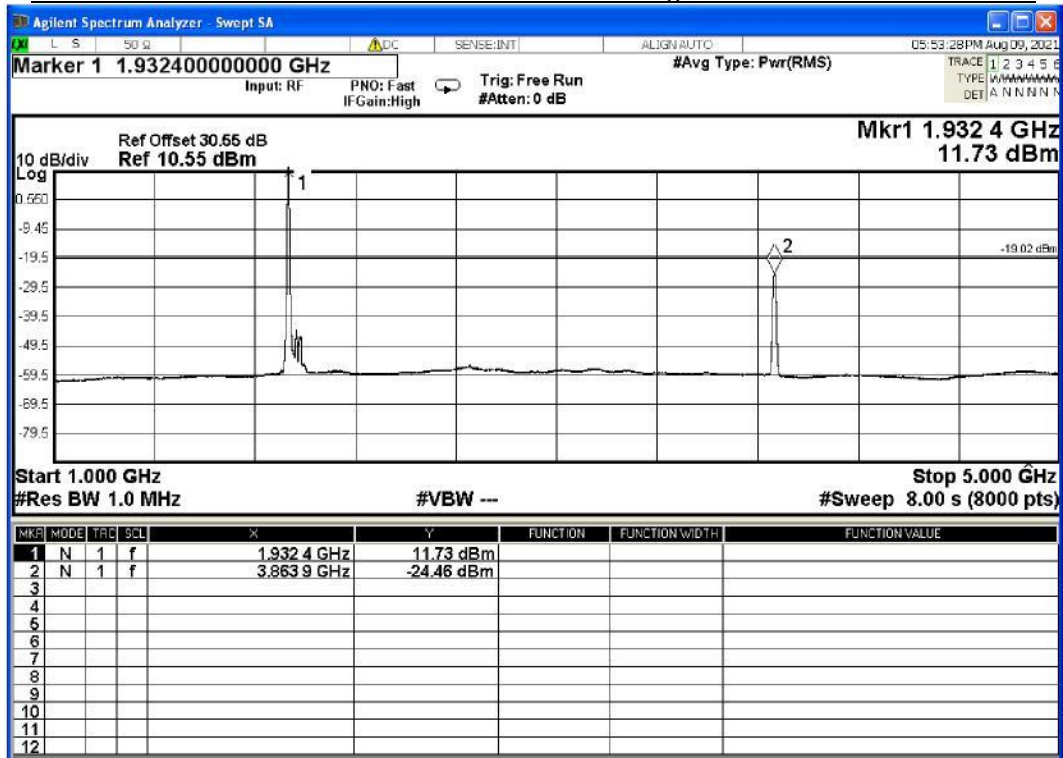



Modulation QPSK - Carrier Bandwidth 5.0 MHz – Range 1GHz to 5GHz: 1960.0 MHz

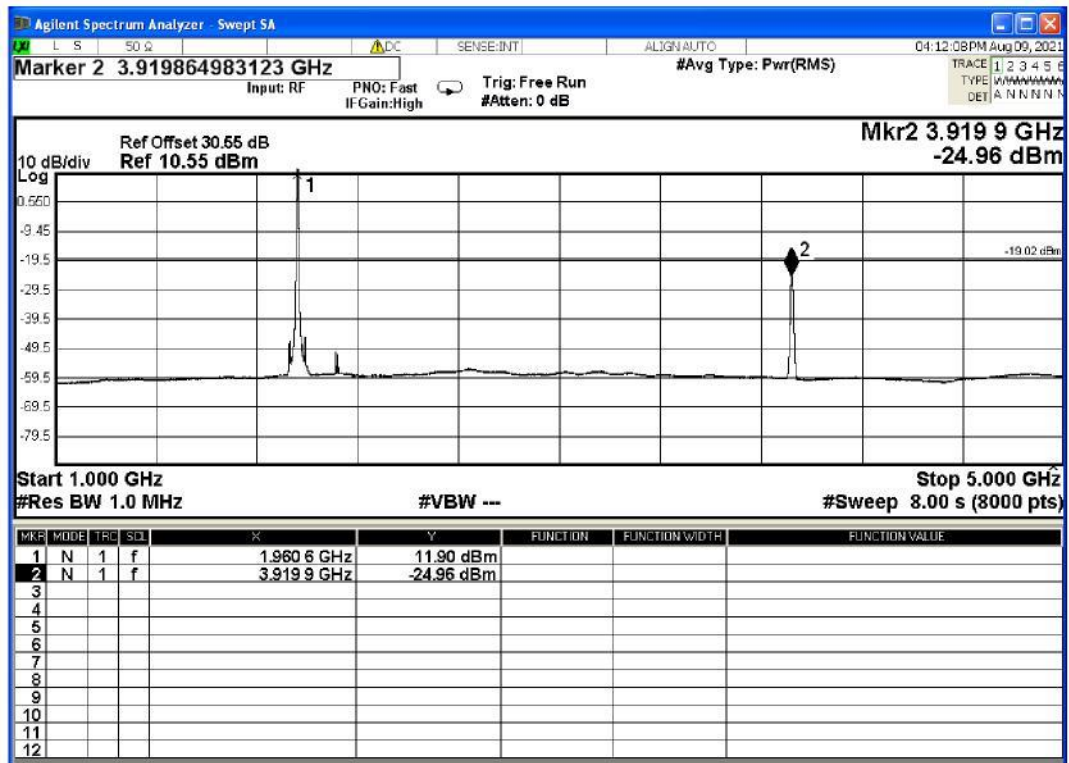

Modulation QPSK - Carrier Bandwidth 5.0 MHz – Range 1GHz to 5GHz: 1962.5 MHz

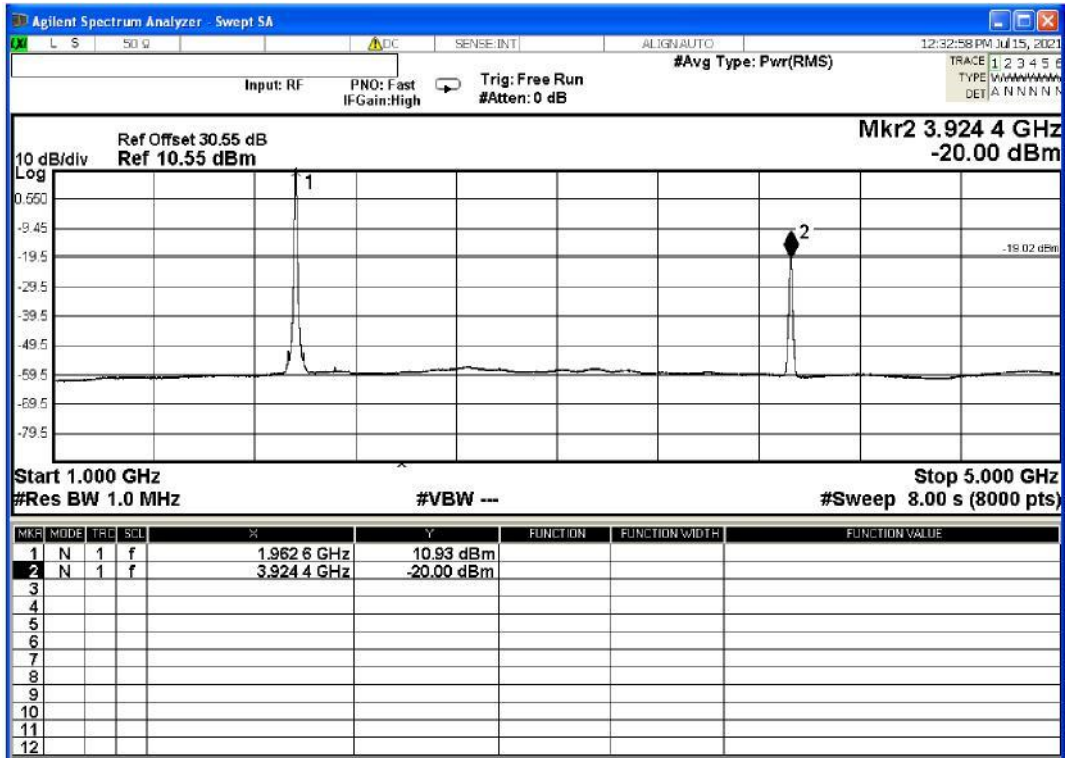



Modulation QPSK - Carrier Bandwidth 5.0 MHz - Range 1G to 5GHz: 1987.5 MHz

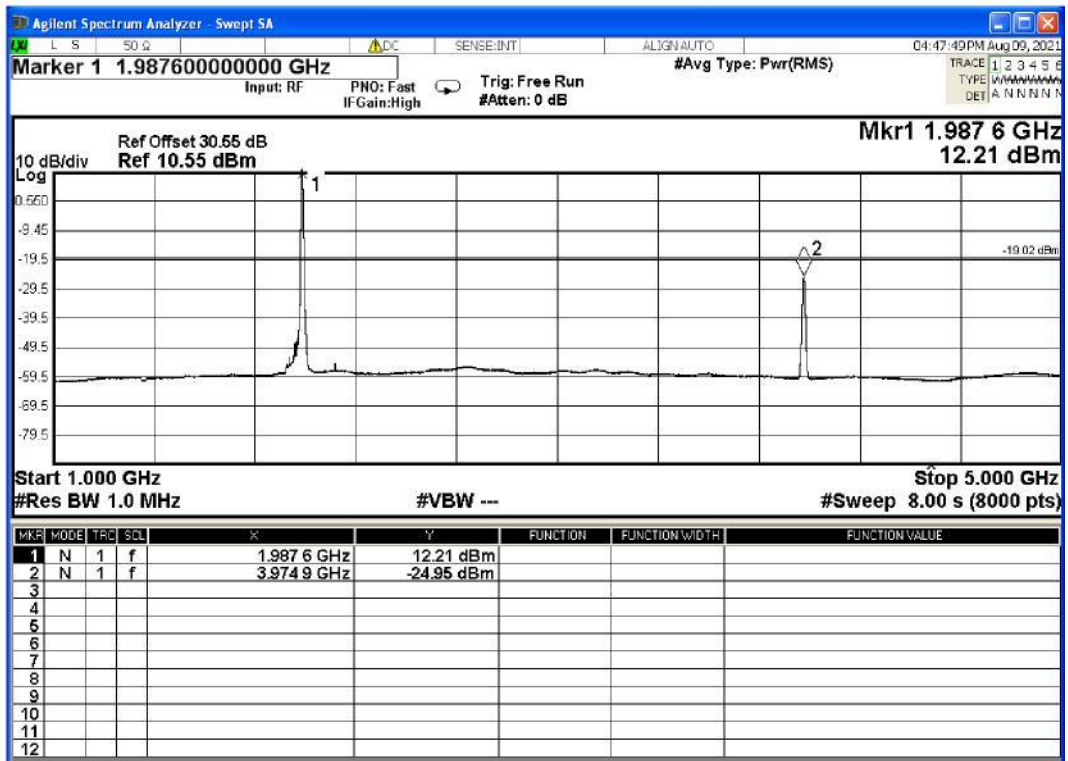

Modulation QPSK - Carrier Bandwidth 5.0 MHz - Range 1G to 5GHz: 1992.5 MHz

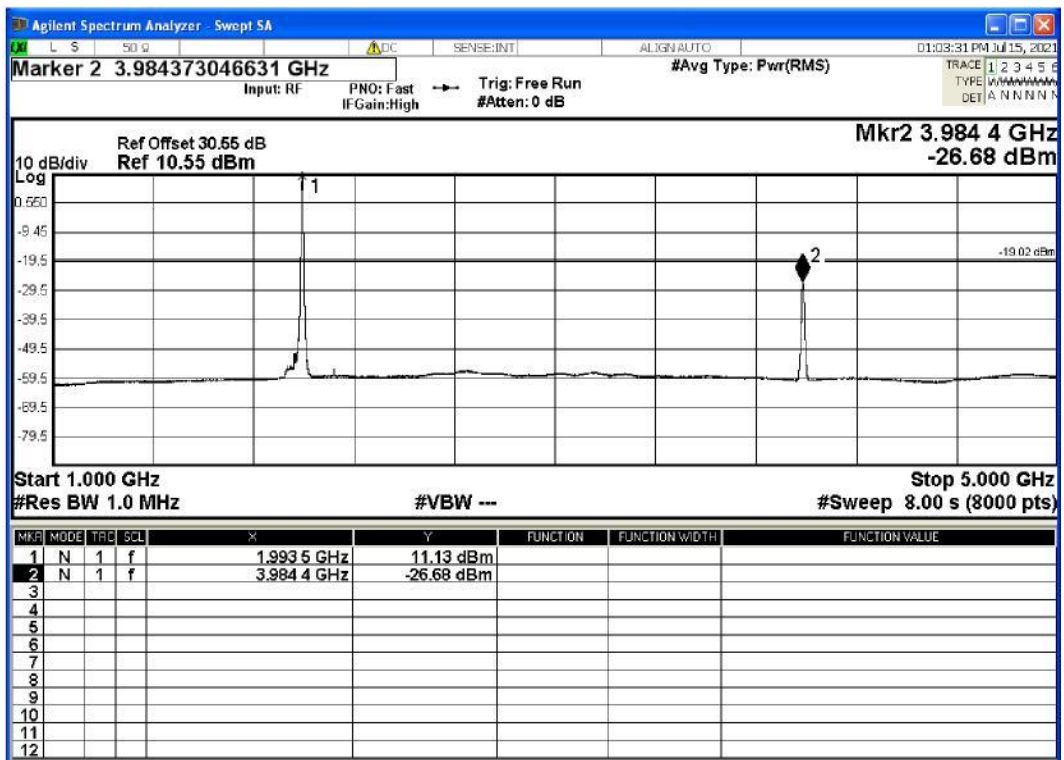



Modulation QPSK - Carrier Bandwidth 5.0 MHz – Range 5GHz to 26GHz

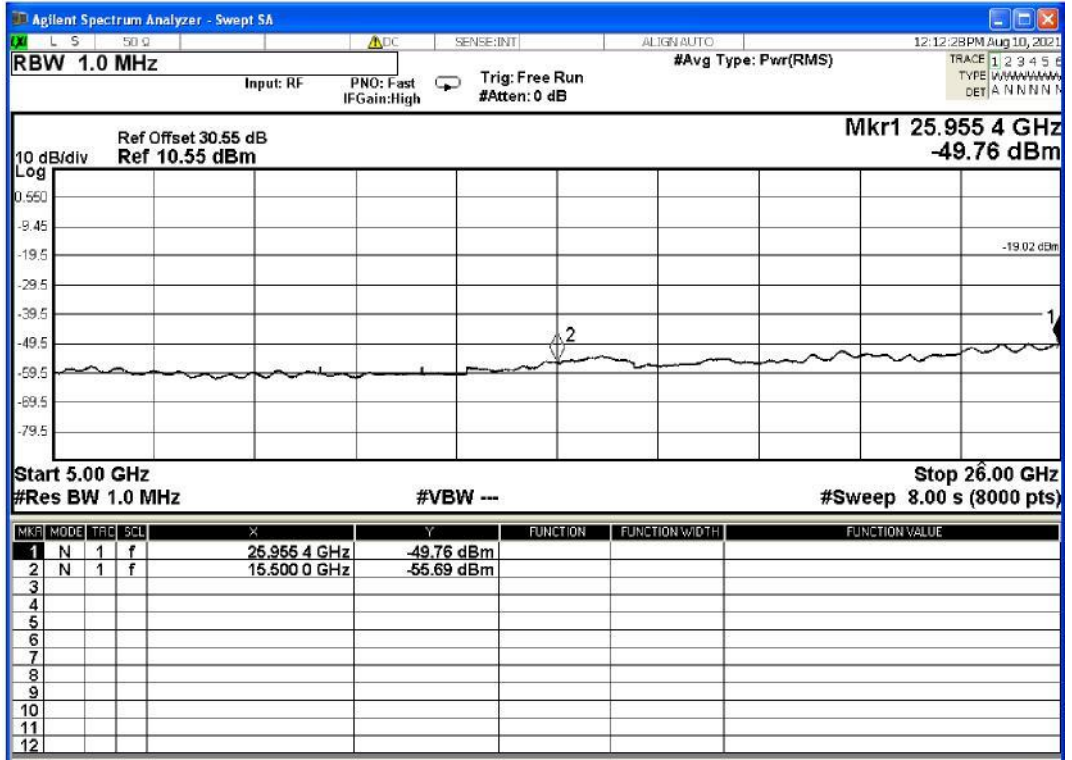



## 2.5 FREQUENCY STABILITY

### 2.5.1 Specification Reference

FCC CFR 47 Part 2, Clause 2.1055  
 FCC CFR 47 Part 24, Clause [§ 24.235](#)

### 2.5.2 Date of Test and Modification State

22 June 2021 - Modification State 0

### 2.5.3 Test Equipment Used

The major items of test equipment used for the above tests are identified in Section 3.1.

### 2.5.4 Environmental Conditions

Ambient Temperature 26.7°C  
 Relative Humidity 32.2%

### 2.5.5 Test Method

All measurements were made in accordance with FCC KDB 971168 D01.

### 2.5.6 Test Results

Maximum Target Output Power 30dBm

#### 2.5.6.1.1 Worst Case – Port 1A

Temperature	Voltage (AC)	Frequency Error (Hz)	Limit ppm <Note 2>	Error/Freq ppm	Result
-30°C	115	Note 1	±1	N/A	<Note 1>
-20°C	115	87.24	±1	0.05	Pass
-10°C	115	34.21	±1	0.02	Pass
0°C	115	31.0	±1	0.02	Pass
+10°C	115	20.50	±1	0.01	Pass
+20°C	115	22.7	±1	0.01	Pass
+20°C	90	21.22	±1	0.01	Pass
+20°C	132	13.17	±1	0.01	Pass
+30°C	115	16.34	±1	0.01	Pass
+40°C	115	18.30	±1	0.01	Pass
+55°C	115	4.62	±1	0.004	Pass

Note 1. EUT stop the operation and no transmission was recorded: Pass  
 The frequency stability shall be sufficient to ensure that the fundamental emissions stay within the authorized bands of operation





## 2.6 FIELD STRENGTH

### 2.6.1 Specification Reference

FCC CFR 47 Part 2.1053  
FCC CFR 47 Part 24E Clause [§ 24.236](#)

### 2.6.2 Date of Test and Modification State

06 June 2021 – Modification State 0  
22 June 2021 – Modification State 0  
05 July 2021 – Modification State 0

### 2.6.3 Test Equipment Used

The major items of test equipment used for the above tests are identified in Section 3.1.

### 2.6.4 Environmental Conditions

Ambient Temperature	23.1°C
Relative Humidity	13.4%

### 2.6.5 Test Method

All measurements were made in accordance with:

- 971168 D01 Power Meas License Digital Systems v03r01 Clause 5.6
- 971168 D01 Power Meas License Digital Systems v03r01 Clause 7

From Clause 5:6, the field strength of the EUT can be calculated by:

$$\text{EIRP} = P_{\text{meas}} + A_{\text{gain}} = 28\text{dBm} + 5\text{dBi} = 33\text{dBm (or } 130.38 \text{ dB}\mu\text{V/m at 3m)}$$

Measurements were performed in configurations of the EUT as reported below. Testing was performed with RF on (Port TX1A) with a test limit of FCC 15 Subpart B Class B of 40 dB $\mu$ V/m, which is more restricted than -19 dBm or 76.23 dB $\mu$ V/m at 3m



### 2.6.6 Test Results

A summary of the test result is depicted in the table below.

Range Frequency	Test Limit (dB $\mu$ V/m)	Limit <Note 1> dB $\mu$ V/m	Result
9kHz to 150kHz	40.0	76.23	Pass <Note 2>
150kHz to 30MHz	40.0	76.23	Pass
30MHz to 1GHz	33.06	76.23	Pass
1GHz to 10GHz	53.96	76.23	Pass
10GHz to 18GHz	53.96	76.23	Pass
18GHz to 40GHz	53.96	76.23	Pass <Note 3>

Note 1. As per CFR 47 27.55(a)(1)  
Note 2. No significant emission (> 20dB margin below the limit) was recorded according to FCC 15 Subpart B.  
Note 3. The device was scanned up to 40Ghz with no emission (peak values less than 6Bd from the limit)



**Spurious Radiation**  
**Spurious Radiation Emission – 150kHz to 30MHz**

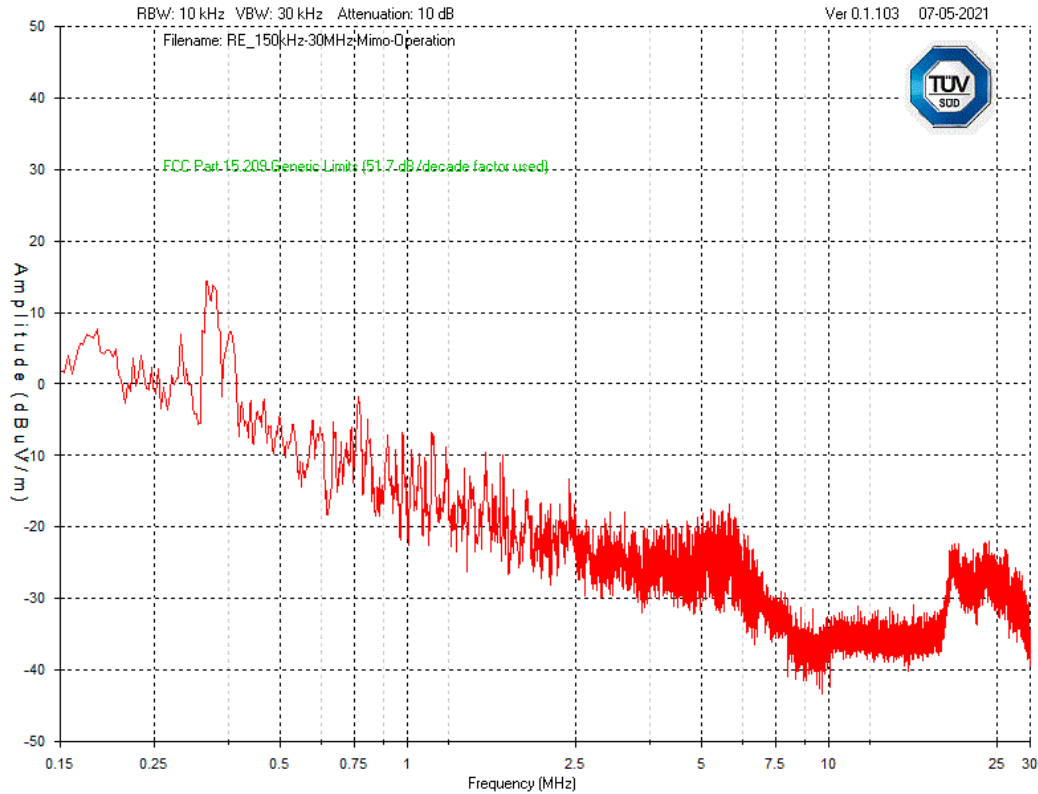

Note 1. The spurious emissions comply with the limit of 76.23 dB $\mu$ V/m at 3m.

Frequency (MHz)	Detector	Raw Reading	Cable 27 - 10m LMR4 00 Factor	Loop - EM687 2 100k to 30M Factor	Pream p-LNA14 50 Factor	Level	FCC Part 15.209 Generic Limits (51.7 dB/decade factor used) Limit	FCC Part 15.209 Generic Limits (51.7 dB/decade factor used) Margin
0.7642	PEAK	31.4	0	-2.3	-31	-1.9	93.3	95.2
1.6872	PEAK	28.5	0.1	-7.4	-31.1	-9.9	86.4	96.3
1.1427	PEAK	28.7	0.1	-4.5	-31	-6.7	89.8	96.5
1.5378	PEAK	28	0.1	-6.6	-31	-9.5	87.2	96.7



## Spurious Radiation Emission –30MHz to 1GHz

"TÜV SÜD, by release of this raw data, does not imply that the tested product has demonstrated compliance to any standard. The raw data provided may not be complete and may require additional processing. If raw data provided includes engineering data, testing may not have been done according to a standard test method. "

Emi CC test:RE_30-1000 MHz 10m - FCC- Class B Number:122 Execution date: 6/22/2021 1:42:24 PM	
Limit	FCC Part 15 Subpart B
Class	Class : B
Test Plan Number	7169009211
Configuration Information	Mode: Operating: Band:891.5MHz (30dBm)
Results	Pass
Model	CBRSYS4450
Tested by	KP and SM
Comments	Port activated: TX1A

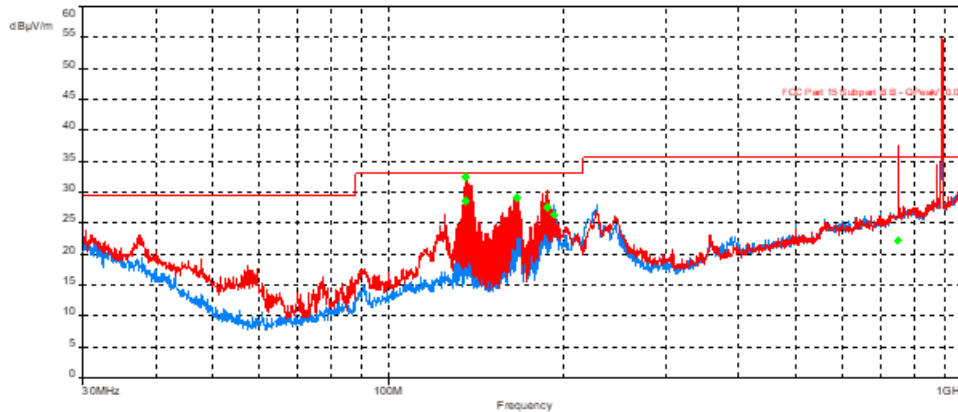

Red=Vertical, Blue=Horizontal

## Finals

Quasi-Peak Detector (6)

Frequency (MHz)	S R	Level (dBµV/m)	Limit (dBµV/m)	Margin (dB)	Height (m) (dB)	Azimuth (°) (dB)	Polarization (dB)	Correction (dB)
135.8700672	1	32.42	33.06	-0.64	1.00	117.75	Vertical	-9.37
166.2925738	1	29.15	33.06	-3.91	1.11	175.25	Vertical	-10.68
187.5651795	1	27.54	33.06	-5.52	1.06	119.75	Vertical	-11.92
749.9822821	1	22.16	35.56	-13.40	1.84	220.75	Vertical	3.69
135.8608141	2	28.49	33.06	-4.57	4.00	112.75	Horizontal	-9.37
192.6622692	2	26.30	33.06	-6.76	3.40	127.25	Horizontal	-11.80

Note 1. The spurious emissions comply with the limit of 76.23 dBµV/m at 3m.

Note 2. Operating at 1992.5MHz, thus emission excluded from FCC limit.



## Spurious Radiation Emission –1GHz to 10GHz

"TÜV SÜD, by release of this raw data, does not imply that the tested product has demonstrated compliance to any standard. The raw data provided may not be complete and may require additional processing. If raw data provided includes engineering data, testing may not have been done according to a standard test method. "

Emi CC test:RE_1-10 GHz 3m - MIMO- FCC Class B Number:129 Execution date: 6/22/2021 3:15:43 PM	
Limit	FCC Part 15 Subpart B
Class	Class: B
Test Plan Number	7169009211
Configuration Information	Mode: Operating
Results	Pass
Model	CBRSYS4450
Tested by	KP and SM
Comments	Port activated: TX1A

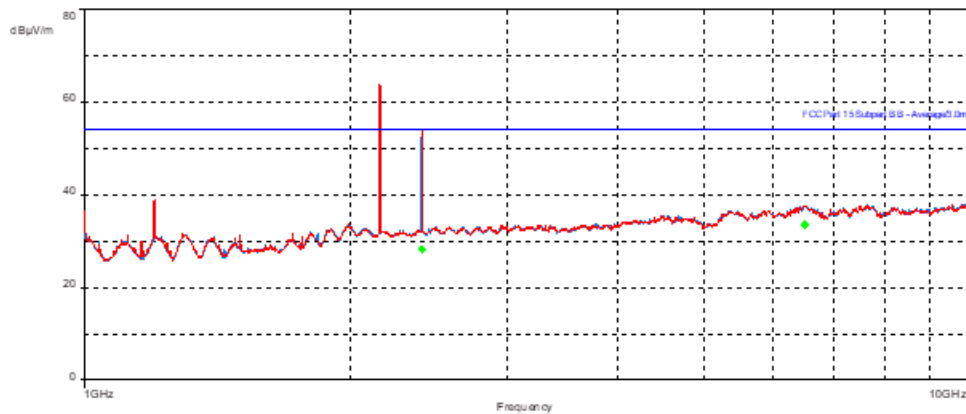

Red=Vertical, Blue=Horizontal

### Finals

AVG (4)								
Frequency (MHz)	SR	Level (dBµV/m)	Limit (dBµV/m)	Margin (dB)	Height (m) (dB)	Azimuth (°) (dB)	Polarization (dB)	Correction (dB)
2405.726603	1	28.27	53.96	-25.69	3.69	9.50	Vertical	-5.79
6492.401603	1	33.47	53.96	-20.49	2.08	343.00	Vertical	1.37
2403.416346	2	28.38	53.96	-25.58	1.00	356.75	Horizontal	-5.81
6513.693269	2	33.56	53.96	-20.40	2.42	2.25	Horizontal	1.35

Note 1. The spurious emissions comply with the limit of 76.23 dBµV/m at 3m.

Note 2. 2.4GHz peak correspond to the computer WIFI communication.



Spurious Radiation Emission –10GHz to 18GHz

"TÜV SÜD, by release of this raw data, does not imply that the tested product has demonstrated compliance to any standard. The raw data provided may not be complete and may require additional processing. If raw data provided includes engineering data, testing may not have been done according to a standard test method. "

Emi CC test:RE_10-18 GHz 3m - MIMO - FCC Class B Number:135 Execution date: 6/23/2021 8:42:04 AM	
Limit	FCC Part 15 Subpart B
Class	Class: B
Test Plan Number	7169009211
Configuration Information	Operation: Band:891.5MHz (30dBm)
Results	Pass
Model	CBRSYS4450
Tested by	KP and SM
Comments	Port activated: TX1A



Red=Vertical, Blue=Horizontal

## Finals

AVG Detector (4)

Frequency (MHz)	S R	Level (dBµV/m)	Limit (dBµV/m)	Margin (dB)	Height (m) (dB)	Azimuth (°) (dB)	Polarization (dB)	Correction (dB)
16750.52277	2	41.61	53.96	-12.35	1.00	10.50	Horizontal	14.25
16753.59519	1	41.97	53.96	-11.99	4.00	271.50	Vertical	14.29
17898.35513	2	41.39	53.96	-12.57	3.86	16.75	Horizontal	14.87
17916.38559	1	41.10	53.96	-12.86	1.00	0.00	Vertical	14.82

Note 1. The spurious emissions comply with the limit of 76.23 dBµV/m at 3m.



## SECTION 3: TEST EQUIPMENT USED



### 3.1 TEST EQUIPMENT USED

List of absolute measurements and other principal items of test equipment.

Instrument	Manufacturer	Type No.	Serial No.	Calibration Period (months)	Calibration Due
Bilog Antenna	TESEQ	CBL 6111D	SSG013965	2021-05-04	2022-05-04
Horn Antenna 3MCH 00003	ETS	3117	LAVE04211	2021-03-30	2022-03-30
EMI Receiver	Rohde & Schwarz	ESU26	SSG013729	2021-03-31	2022-03-31
EMI Receiver	Rohde & Schwarz	ESU40	SSG013672	2020-10-29	2021-10-29
Coaxial Cable	Huber & Suhner	106A	SSG012455	2021-01-05	2022-01-05
Coaxial Cable	Huber & Suhner	106A	SSG012711	2021-01-05	2022-01-05
Coaxial Cable	Huber & Suhner	104PEA	SSG012041	2021-01-05	2022-01-05
Coaxial Cable	Huber & Suhner	ST18/Nm/Nm/36	SSG012785	2021-01-06	2022-01-06
Coaxial Cable	Micro-Coax	UFA 210B-1-1500-504504	SSG012376	2021-01-06	2022-01-06
Pre-Amplifier	Hp	8447D	LAVE04346	2020-09-10	2021-09-10
Pre-Amplifier	BNR	LNA	SSG012360	2020-11-16	2021-11-16
Power Supply	Hewlett Packard	6216A	SSG013063	not required	not required
N/A: No applicable O/P Mon – Output monitored with Calibrated Equipment					





### 3.2 MEASUREMENT UNCERTAINTY

For a 95% confidence level, the measurement uncertainties for defined systems are:

Test Discipline	Frequency / Parameter	MU
Conducted Maximum Peak Output Power	30 MHz to 20 GHz Amplitude	± 0.1 dB
Conducted Emissions	30 MHz to 20 GHz Amplitude	± 2.3 dB
Frequency Stability	30 MHz to 2 GHz	± 5.0 Hz
Occupied Bandwidth	Up to 20 MHz Bandwidth	± 1.1 Hz
Band Edge	30 MHz to 20 GHz Amplitude	± 2.3 dB



## **SECTION 5**

### **ACCREDITATION, DISCLAIMERS AND COPYRIGHT**



#### 4.1 ACCREDITATION, DISCLAIMERS AND COPYRIGHT



Testing Laboratory  
Certificate #2955.19

This report relates only to the actual item/items tested.

This report does not imply product endorsement by any government, accreditation agency, or TÜV SÜD Canada Inc.

Opinions or interpretations expressed in this report, if any, are outside the scope of TÜV SÜD Canada Inc. accreditations. Any opinions expressed do not necessarily reflect the opinions of TÜV SÜD Canada Inc., unless otherwise stated.

This report relates only to the actual item/items tested.

© 2021 TÜV SÜD