

1 Product Overview

DCPLSCA is an embedded Bluetooth low energy (BLE) module that Tuya has developed. It consists of a highly integrated Bluetooth chip (TLSR8250F512ET32) and several peripheral components, with an embedded Bluetooth network protocol stack and robust library functions. BT3L also contains a low-power 32-bit multipoint control unit (MCU), BLE 5.0 component, 2.4 GHz radio component, 4 MB flash memory, 48 KB static random-access memory (SRAM), and nine multiplexing I/O interfaces.

1.1 Features

- ◇ Embedded low-power 32-bit MCU, which can also function as an application processor
 - Dominant frequency: 48 MHz
- ◇ Working voltage: 1.8 V to 3.6 V (Under 1.8 V to 2.7 V, the module can start but the RF performance is not guaranteed. Under 2.8 V to 3.6 V, the module performance is normal.)
- ◇ Peripherals: nine pulse width modulation (PWM) interfaces
- ◇ BLE RF features
 - Compatible with BLE 5.0
 - Up to 1 Mbit/s is RF data rate
- Embedded advanced encryption standard (AES) hardware encryption
- Onboard PCB antenna with 2.5 dBi gain

- Working temperature: -20°C to $+85^{\circ}\text{C}$

1.2 Applications

- ◇ Smart LED lights
- ◇ Smart households
- ◇ Smart low-power sensors

2 Module Interfaces

2.1 Dimensions and Footprint

BT3L has two rows of pins with a 2 mm pin spacing.

The BT3L dimensions (H x W x D) are 3.3 ± 0.15 mm x 16 ± 0.35 mm x 24 ± 0.35 mm. The PCB thickness is 0.8 ± 0.1 mm. Figure 2-1 shows the BT3L pins.

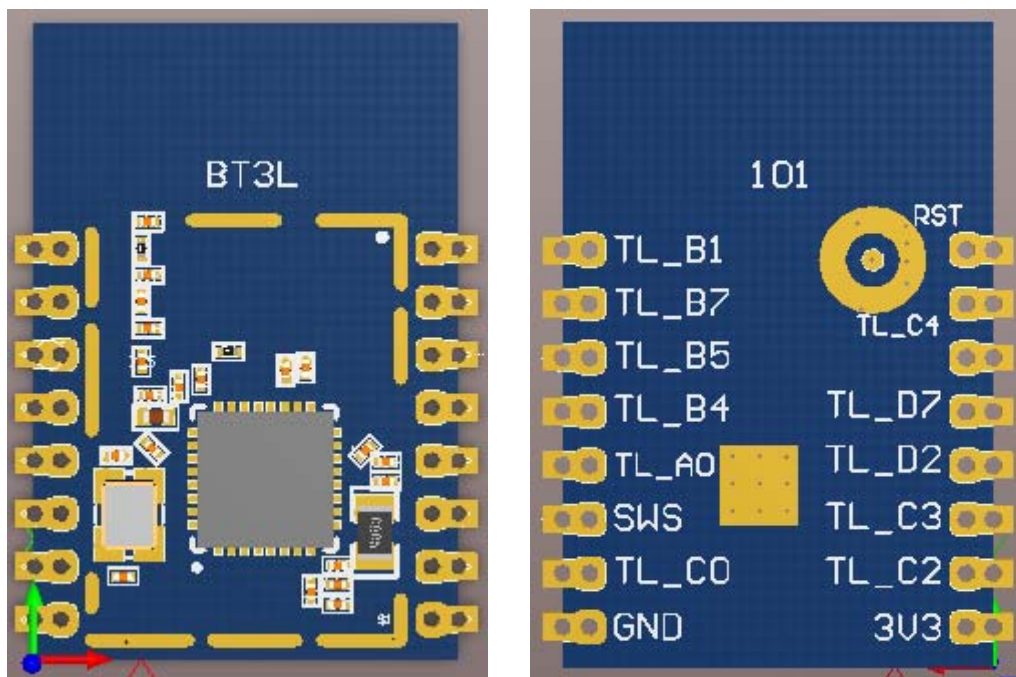

Figure 2-1 BT3L pins

2.2 Interface Pin Definition

Table 2-1 BT3L interface pins

Pin No.	Symbol	I/O Type	Function
1	RST	I/O	Hardware reset pin, which is active at a low level and is connected to pin 25 on the IC
2	ADC	AI	12-bit ADC, which is connected to pin 24 on the IC
3	NC	I/O	NC
4	TL_D7	I/O	GPIO, which is connected to pin 2 on the IC
5	TL_D2	I/O	Common I/O, which can be used as a PWM output of the LED drive and is connected to pin 31 on the IC
6	TL_C3	I/O	Common I/O, which can be used as a PWM output of the LED drive and is connected to pin 23 on the IC
7	TL_C2	I/O	Common I/O, which can be used as a PWM output of the LED drive and is connected to pin 22 on the IC
8	VDD_BAT	P	Power supply pin (3.3 V)
9	GND	P	Power supply reference ground pin
10	TL_C0	I/O	GPIO, which is connected to pin 20 on the IC
11	SWS	Input	Programming pin, which is connected to pin 5 on the IC

Pin No.	Symbol	I/O Type	Function
12	TL_A0	I/O	GPIO, which is connected to pin 3 on the IC
13	TL_B4	I/O	Common I/O, which can be used as a PWM output of the LED drive and is connected to pin 14 on the IC
14	TL_B5	I/O	Common I/O, which can be used as a PWM output of the LED drive and is connected to pin 15 on the IC
15	TL_B7	I/O	Serial interface receiving pin (UART RX), which is connected to pin 17 on the IC
16	TL_B1	I/O	Serial interface transmission pin (UART TX), which is connected to pin 6 on the IC

Note:

1. **P** indicates power supply pins, **I/O** indicates input/output pins, and **AI** indicates analog input pins.
2. If you have special requirements for light colors controlled by PWM outputs, contact Tuya business personnel.

3 Electrical Parameters

3.1 Absolute Electrical Parameters

Table 3-1 Absolute electrical parameters

Parameter	Description	Minimum Value	Maximum Value	Unit
T _s	Storage temperature	-65	150	°C
V _{CC}	Power supply voltage	-0.3	3.9	V
Static electricity voltage (human body model)	T _{amb} = 25°C	N/A	2	kV
Static electricity voltage (machine model)	T _{amb} = 25°C	N/A	0.5	kV

3.2 Electrical Conditions

Table 3-2 Normal electrical conditions

Parameter	Description	Minimum Value	Typical Value	Maximum Value	Unit
T _a	Working temperature	-20	N/A	85	°C
V _{CC}	Working voltage	2.8	3.3	3.6	V
V _{IH}	I/O high-	V _{CC} x 0.7	N/A	V _{CC}	V

Parameter	Description	Minimum Value	Typical Value	Maximum Value	Unit
	level input				
V_{OL}	I/O low-level output	VSS	N/A	$VCC \times 0.1$	V
V_{OH}	I/O high-level output	$VCC \times 0.9$	N/A	VCC	V

3.3 Working Current

Table 3-3 Current during constant transmission and receiving

Symbol	Description	Typical Value	Unit
I_{tx}	Constant transmission, 0 dBm output power	6.7	mA
I_{rx}	Constant receiving	6.3	mA
I_{DC}	Connected to a mesh network	7.4	mA
$I_{deepsleep1}$	Deep sleep mode 1 (16 KB RAM is reserved.)	1.2	μA
$I_{deepsleep2}$	Deep sleep mode 2 (No RAM is reserved.)	0.4	μA

4 RF Features

4.1 Basic RF Features

Table 4-1 Basic RF features

Parameter	Description
Frequency band	2.4 GHz ISM band
Wireless standard	BLE 5.0
Data transmission rate	1 Mbit/s
Antenna type	Onboard PCB antenna

4.2 RF Output Power

Table 4-2 Power during constant transmission

Parameter	Minimum Value	Typical Value	Maximum Value	Unit
Average RF output power	-22	10	10.5	dBm
20 dB modulation signal bandwidth (1 Mbit/s)	N/A	2500	N/A	kHz
20 dB modulation signal bandwidth (2 Mbit/s)	N/A	1400	N/A	kHz

4.3 RF RX Sensitivity

Table 4-3 RX sensitivity

Parameter		Minimum Value	Typical Value	Maximum Value	Unit
RX sensitivity	1 Mbit/s	N/A	-94.5	N/A	dBm
	2 Mbit/s	N/A	-91	N/A	
Frequency offset	1 Mbit/s	-250	N/A	+300	kHz
	2 Mbit/s	-300	N/A	+200	
Co-channel interference suppression	N/A	N/A	-10	N/A	dB

5 Antenna Information

5.1 Antenna Type

DCPLSCA uses an onboard PCB antenna.

5.2 Antenna Interference Reduction

To ensure optimal RF performance, it is recommended that the antenna be at least 15 mm away from other metal parts. If metal materials are wrapped around the antenna, the wireless signals will be reduced greatly, deteriorating the RF performance. Because DCPLSCA is inserted to the PCB, sufficient space needs to be reserved for the antenna.

6 Packaging Information and Production Instructions

6.1 Mechanical Dimensions

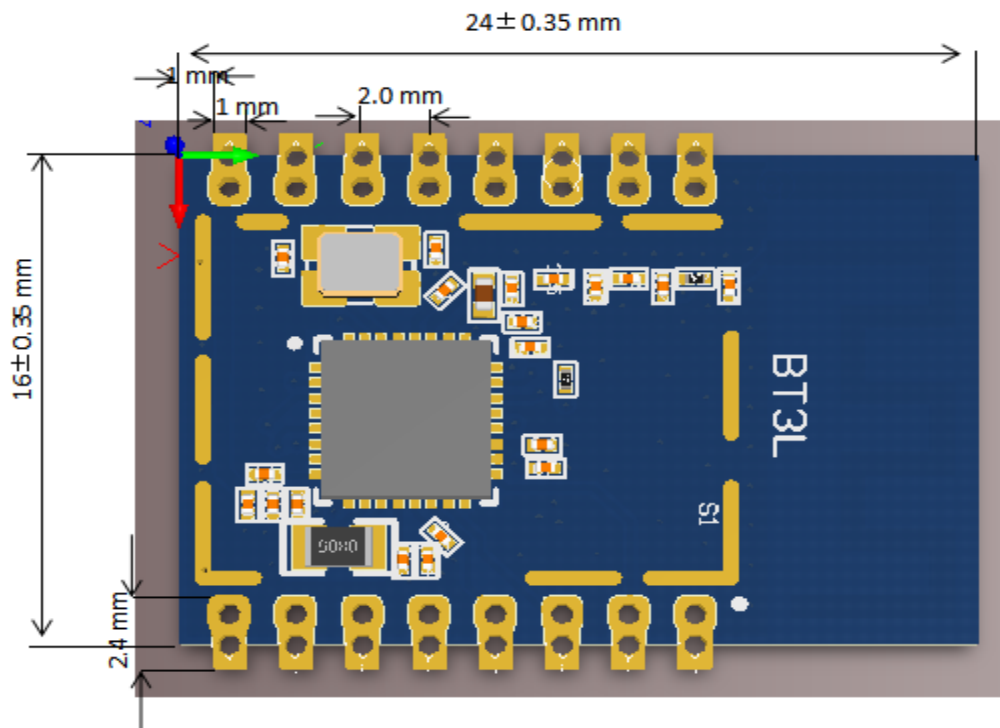

Figure 6-1 BT3L mechanical dimensions

Note:

The default dimensional tolerance is ± 0.35 mm, and the tolerance for some measurements is ± 0.1 mm. If a customer has other requirements, clearly specify them in the datasheet after communication.

6.2 Production Instructions

1. Use an SMT placement machine to mount components to the stamp hole module that Tuya produces within 24 hours after the module is unpacked and the firmware is burned. If not, vacuum pack the module again. Bake the module before mounting components to the module.
 - (1) SMT placement equipment
 - i. Reflow soldering machine
 - ii. Automated optical inspection (AOI) equipment
 - iii. Nozzle with a 6 mm to 8 mm diameter
 - (2) Baking equipment
 - i. Cabinet oven
 - ii. Anti-static heat-resistant trays
 - iii. Anti-static heat-resistant gloves
2. Storage conditions for a delivered module are as follows:
 - (1) The moisture-proof bag is placed in an environment where the temperature is below 30°C and the relative humidity is lower than 70%.
 - (2) The shelf life of a dry-packaged product is six months from the date when the product is packaged and sealed.
 - (3) The package contains a humidity indicator card (HIC).

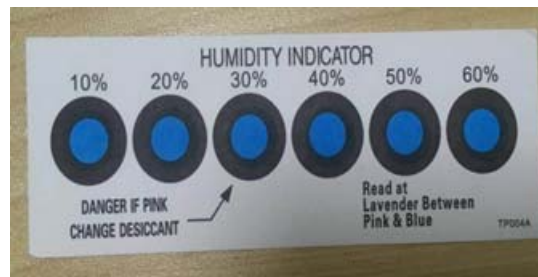

Figure 6-2 HIC for BT3L

3. Bake a module based on HIC status as follows when you unpack the module package:
 - (1) If the 30%, 40%, and 50% circles are blue, bake the module for 2 consecutive hours.
 - (2) If the 30% circle is pink, bake the module for 4 consecutive hours.
 - (3) If the 30% and 40% circles are pink, bake the module for 6 consecutive hours.
 - (4) If the 30%, 40%, and 50% circles are pink, bake the module for 12 consecutive hours.
4. Baking settings:
 - (1) Baking temperature: $125\pm 5^{\circ}\text{C}$
 - (2) Alarm temperature: 130°C
 - (3) SMT placement ready temperature after natural cooling: $< 36^{\circ}\text{C}$
 - (4) Number of drying times: 1
 - (5) Rebaking condition: The module is not soldered within 12 hours after baking.
5. Do not use SMT to process modules that have unpacked for over three months. Electroless nickel immersion gold (ENIG) is used for the PCBs. If the solder pads are exposed to the air for over three months, they will be oxidized severely and dry joints or solder skips may occur. Tuya is not liable for such problems and consequences.
6. Before SMT placement, take electrostatic discharge (ESD) protective measures.
7. To reduce the reflow defect rate, draw 10% of the products for visual inspection and AOI before first SMT placement to determine a proper oven temperature and component placement method. Draw 5 to 10 modules every hour from subsequent batches for visual inspection and AOI.

6.3 Recommended Oven Temperature Curve

Perform SMT placement based on the following reflow oven temperature curve. The highest temperature is 245°C .

Based on the IPC/JEDEC standard, perform reflow soldering on a module at most twice.

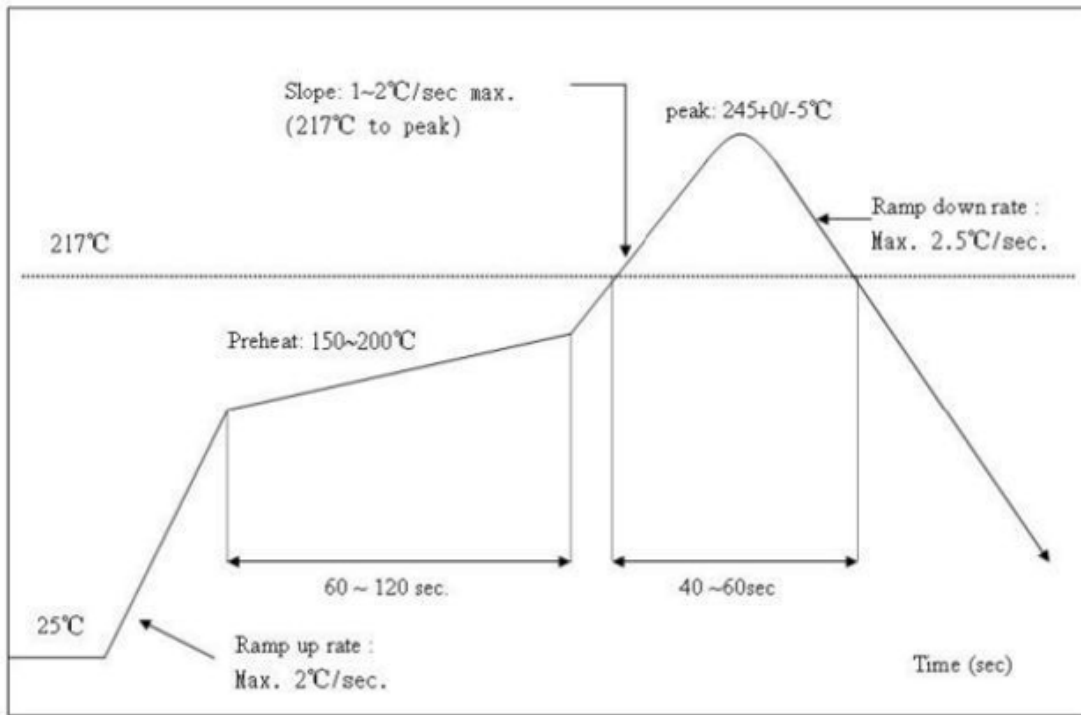

Figure 6-3 Oven temperature curve

7 MOQ and Packing Information

MOQ and Packing Information				
Product Model	MOQ (PCS)	Packing Method	Number of Modules in Each Reel Pack	Number of Reel Packs in Each Box
BT3L	3600	Carrier tape and reel packing	900	4

Integration instructions for host product manufacturers according to KDB 996369 D03 OEM

Manual v01

1. List of applicable FCC rules

FCC Part 15 Subpart C 15.247 & 15.209

2. Specific operational use conditions

The module with BLE

Operation Frequency: 2402-2480MHz;

Number of Channel: 40 Channel

Modulation: GFSK

Type:PCB Antenna

Gain: 2.5dBi.

The module can be used for mobile or portable applications with a maximum 2.5dBi antenna. The host manufacturer installing this module into their product must ensure that the final composite product complies with the FCC requirements by a technical assessment or evaluation to the FCC rules, including the transmitter operation. The host manufacturer has to be aware not to provide information

3. Limited module procedures

Not applicable. The module is a Single module and complies with the requirement of FCC Part 15.212.

4. Trace antenna designs

Not applicable. The module has its own antenna, and doesn't need a host's printed board microstrip trace antenna etc.

5. RF exposure considerations

The module must be installed in the host equipment such that at least 20cm is maintained between the antenna and users' body; and if RF exposure statement or module layout is changed, then the host product manufacturer required to take responsibility of the module through a change in FCC ID or new application. The FCC ID of the module cannot be used on the final product. In these circumstances, the host manufacturer will be responsible for re-evaluating the end product (including the transmitter) and obtaining a separate FCC authorization.

6. Antennas

Antenna Specification are as follows:

Type: PCB Antenna

Gain: 2.5dBi.

This device is intended only for host manufacturers under the following conditions:

The transmitter module may not be co-located with any other transmitter or antenna;

The module shall be only used with the internal antenna(s) that has been originally tested and certified with this module. The antenna must be either permanently attached or employ a 'unique' antenna coupler.

As long as the conditions above are met, further transmitter test will not be required. However, the host manufacturer is still responsible for testing their end-product for any additional compliance requirements required with this module installed (for example, digital device emissions, PC peripheral requirements, etc.).

7. Label and compliance information

Host product manufacturers need to provide a physical or e-label stating “Contains FCC ID: **2AQSN-DCPLSCA**” with their finished product.

8. Information on test modes and additional testing requirements

Operation Frequency: 2402-2480MHz

Number of Channel: 40 Channel

Host manufacturer must perform test of radiated & conducted emission and spurious emission, etc according to the actual test modes for a stand-alone modular transmitter in a host, as well as for multiple simultaneously transmitting modules or other transmitters in a host product.

Only when all the test results of test modes comply with FCC requirements, then the end product can be sold legally.

9. Additional testing, Part 15 Subpart B disclaimer

The modular transmitter is **only** FCC authorized for FCC Part 15 Subpart C 15.247 & 15.209 and that the host product manufacturer is responsible for compliance to any other FCC rules that apply to the host not covered by the modular transmitter grant of certification. If the grantee markets their product as being Part 15 Subpart B compliant (when it also contains unintentional-radiator digital circuitry), then the grantee shall provide a notice stating that the final host product still requires Part 15 Subpart B compliance testing with the modular transmitter installed.

Federal Communication Commission Statement (FCC, U.S.)

This equipment has been tested and found to comply with the limits for a Class B digital device, pursuant to Part 15 of the FCC Rules. These limits are designed to provide reasonable protection against harmful interference in a residential installation. This equipment generates, uses and can radiate radio frequency energy and, if not installed and used in accordance with the instructions, may cause harmful interference to radio communications. However, there is no guarantee that interference will not occur in a particular installation. If this equipment does cause harmful interference to radio or television reception, which can be determined by turning the equipment off and on, the user is encouraged to try to correct the interference by one of the following measures:

- Reorient or relocate the receiving antenna.
- Increase the separation between the equipment and receiver.
- Connect the equipment into an outlet on a circuit different from that to which the receiver is connected.
- Consult the dealer or an experienced radio/TV technician for help.

This device complies with Part 15 of the FCC Rules. Operation is subject to the following two conditions: (1) This device may not cause harmful interference, and (2) this device must accept any interference received, including interference that may cause undesired operation.

FCC Caution:

Any changes or modifications not expressly approved by the party responsible for compliance could void the user's authority to operate this equipment.

IMPORTANT NOTES

Co-location warning:

This transmitter must not be co-located or operating in conjunction with any other antenna or transmitter.

OEM integration instructions:

This device is intended only for OEM integrators under the following conditions:

The transmitter module may not be co-located with any other transmitter or antenna. The module shall be only used with the external antenna(s) that has been originally tested and certified with this module.

As long as the conditions above are met, further transmitter test will not be required. However, the OEM integrator is still responsible for testing their end-product for any additional compliance requirements required with this module installed (for example, digital device emissions, PC peripheral requirements, etc.).

Validity of using the module certification:

In the event that these conditions cannot be met (for example certain laptop configurations or co-location with another transmitter), then the FCC authorization for this module in combination with the host equipment is no longer considered valid and the FCC ID of the module cannot be used on the final product. In these circumstances, the OEM integrator will be responsible for re-evaluating the end product (including the transmitter) and obtaining a separate FCC authorization.

End product labeling:

The final end product must be labeled in a visible area with the following: "Contains Transmitter Module [FCC ID: 2AQSN-DCPLSCA](#)".

Information that must be placed in the end user manual:

The OEM integrator has to be aware not to provide information to the end user regarding how to install or remove this RF module in the user's manual of the end product which integrates this module. The end user manual shall include all required regulatory information/warning as show in this manual.

ISED Statement

- English: This device complies with Industry Canada license-exempt RSS standard(s). Operation is subject to the following two conditions: (1) This device may not cause interference, and (2) This device must accept any interference, including interference that may cause undesired operation of the device.

The digital apparatus complies with Canadian CAN ICES-3 (B)/NMB-3(B).

- French: Le présent appareil est conforme aux CNR d'Industrie Canada applicables aux appareils radio exempts de licence. L'exploitation est autorisée aux deux conditions suivantes: (1) l'appareil ne doit pas produire de brouillage, et (2) l'utilisateur de l'appareil doit accepter tout brouillage radioélectrique subi, même si le brouillage est susceptible d'en compromettre le fonctionnement.

l'appareil numérique du ciem conforme canadien peut - 3 (b) / nmb - 3 (b).

This device meets the exemption from the routine evaluation limits in section 2.5 of RSS 102 and compliance with RSS 102 RF exposure, users can obtain Canadian information on RF exposure and compliance.

cet appareil est conforme à l'exemption des limites d'évaluation courante dans la section 2.5 du cnr - 102 et conformité avec rss 102 de l'exposition aux rf, les utilisateurs peuvent obtenir des données canadiennes sur l'exposition aux champs rf et la conformité.

This equipment complies with Canada radiation exposure limits set forth for an uncontrolled environment.

Cet équipement est conforme Canada limites d'exposition aux radiations dans un environnement non contrôlé.

This equipment should be installed and operated with minimum distance 20cm between the radiator & your body.

Cet équipement doit être installé et utilisé à une distance minimale de 20 cm entre le radiateur et votre corps.

Notice to OEM integrator

Must use the device only in host devices that meet the ISED RF exposure category of mobile, which means the device is installed and used at distances of at least 20cm from persons.

Host manufacturer is responsible for compliance of the host system with module installed with all other applicable requirements for the system such as ICES 003.

Host manufacturer is strongly recommended to confirm compliance with ISED requirements for the transmitter when the module is installed in the host.

Must have on the host device a label showing IC: 10733A-DCPLSCA.

The OEM integrator has to be aware not to provide information to the end user regarding how to install or remove this RF module in the user's manual of the end product which integrates this module. The end user manual shall include all required regulatory information/warning as show in this manual.

Antenna Specification are as follows: Type: PCB Antenna Gain: 2.5dBi

This module is restricted for use with the specific antenna(s) tested in this application for Certification and must not be co-located or operating in conjunction with any other antenna or transmitters within a host device, otherwise, a Class II Permissive Change (C2PC) must be filed with IC, or a new IC authorization must be applied.

ISED Modular Usage Statement

NOTE 1: When the ISED certification number is not visible when the module is installed inside another device, then the outside of the device into which the module is installed must also display a label referring to the enclosed module. This exterior label can use the wording "Contains transmitter module IC: 10733A-DCPLSCA" or "Contains IC: 10733A-DCPLSCA".

NOTE 1: Lorsque le numéro de certification ISED n'est pas visible lorsque le module est installé dans un autre appareil, l'extérieur de l'appareil dans lequel le module est installé doit également afficher une étiquette faisant référence au module inclus. Cette étiquette extérieure peut être libellée Contient le module émetteur IC: 10733A-DCPLSCA ou Contient IC: 10733A-DCPLSCA.