



Shenzhen CTA Testing Technology Co., Ltd.

Room 106, Building 1, Yibaolai Industrial Park, Qiaotou Community, Fuhai Street, Bao'an District, Shenzhen, China

FCC PART 22/24 TEST REPORT

FCC Part 22 /Part 24

Report Reference No.....: CTA24062101505

FCC ID.....: 2AQRM-T10A

Compiled by ( position+printed name+signature)...: File administrators Jinghua Xiao

Jinghua Xiao

Supervised by ( position+printed name+signature)...: Project Engineer Lushan Kong

Lushan Kong approved

Approved by ( position+printed name+signature)...: RF Manager Eric Wang

Eric Wang

Date of issue.....: Jul. 14, 2024

Testing Laboratory Name .....: Shenzhen CTA Testing Technology Co., Ltd.

Address .....: Room 106, Building 1, Yibaolai Industrial Park, Qiaotou Community, Fuhai Street, Bao'an District, Shenzhen, China

Applicant's name.....: FOXX Development Inc.

Address .....: 3480 Preston Ridge Road, Suite500 Alpharetta Georgia 30005 United States

Test specification .....

Standard .....: FCC Part 22: PUBLIC MOBILE SERVICES

Standard .....: FCC Part 24: PERSONAL COMMUNICATIONS SERVICES

Shenzhen CTA Testing Technology Co., Ltd. All rights reserved.

This publication may be reproduced in whole or in part for non-commercial purposes as long as the Shenzhen CTA Testing Technology Co., Ltd. is acknowledged as copyright owner and source of the material. Shenzhen CTA Testing Technology Co., Ltd. takes no responsibility for and will not assume liability for damages resulting from the reader's interpretation of the reproduced material due to its placement and context.

Test item description .....: PC TABLETS

Trade Mark .....: FOXX

Manufacturer .....: Shenzhen HommPro Technology Co.,Ltd

Model/Type reference.....: T10A

Ratings .....: DC 3.7V From Battery and DC 5.0V From external circuit

Frequency.....: GSM 850MHz; PCS 1900MHz;

Modulation .....: GMSK

GPRS.....: Supported

Result.....: PASS

# TEST REPORT

Equipment under Test : PC TABLETS

Model /Type : T10A

Listed Models : N/A

**Applicant** : **FOXX Development Inc.**

Address : 3480 Preston Ridge Road, Suite500 Alpharetta Georgia 30005  
United States

**Manufacturer** : **Shenzhen HommPro Technology Co.,Ltd**

Address : 3rd floor, No 27-5, Xintang Road, Xintian Community, Fuhai  
Shenzhen, China

<b>Test Result:</b>	<b>PASS</b>
---------------------	-------------

The test report merely corresponds to the test sample.  
It is not permitted to copy extracts of these test result without the written permission of the test laboratory.

## Contents

1	TEST STANDARDS.....	4
2	SUMMARY.....	5
2.1	General Remarks .....	5
2.2	Product Description .....	5
2.3	Equipment under Test .....	5
2.4	Short description of the Equipment under Test (EUT) .....	6
2.5	EUT configuration.....	6
2.6	Related Submittal(s) / Grant (s).....	6
2.7	Modifications.....	6
2.8	General Test Conditions/Configurations .....	6
2.9	Modifications.....	6
3	TEST ENVIRONMENT .....	7
3.1	Address of the test laboratory.....	7
3.2	Test Facility .....	7
3.3	Environmental conditions .....	7
3.4	Test Description.....	7
3.5	Equipments Used during the Test.....	9
4	TEST CONDITIONS AND RESULTS .....	11
4.1	Output Power.....	11
4.2	Radiated Spurious Emission .....	15
4.3	Occupied Bandwidth and Emission Bandwidth .....	18
4.4	Band Edge Complicance .....	22
4.5	Spurious Emission on Antenna Port .....	25
4.6	Frequency Stability Test.....	37
4.7	Peak-to-Average Ratio (PAR) .....	41
5	Test Setup Photos of the EUT .....	44
6	External and Internal Photos of the EUT .....	44

# **1 TEST STANDARDS**

The tests were performed according to following standards:

[FCC Part 2](#): FREQUENCY ALLOCATIONS AND RADIO TREATY MATTERS; GENERAL RULES AND REGULATIONS

[FCC Part 22 Subpart H](#): PRIVATE LAND MOBILE RADIO SERVICES.

[FCC Part 24 Subpart E](#): PUBLIC MOBILE SERVICES

[ANSI/TIA-603-E-2016](#): Land Mobile FM or PM Communications Equipment Measurement and Performance Standards.

[ANSI C63.26-2015](#): IEEE/ANSI Standard for Compliance Testing of Transmitters Used in Licensed Radio Services

[FCC KDB971168D01](#) Power Meas License Digital Systems

## 2 SUMMARY

### 2.1 General Remarks

Date of receipt of test sample	:	Jun. 19, 2024
Testing commenced on	:	Jun. 19, 2024
Testing concluded on	:	Jul. 14, 2024

### 2.2 Product Description

Product Name:	PC TABLETS
Model/Type reference:	T10A
Power supply:	DC 3.7V From Battery and DC 5.0V From external circuit
Adapter information (Auxiliary test supplied by test Lab):	Model: SR-D505U Input: AC 100-240V 50/60Hz 0.3A Output: DC 5.0V 2.0A 10.0W
Hardware version:	V1.0
Software version:	V1.0
Testing sample ID:	CTA240621015-1# (Engineer sample) CTA240621015-2# (Normal sample)
Modulation Type	GMSK
Antenna Type	PIFA Antenna
GSM/EDGE/GPRS	Supported GSM/GPRS
GSM/GPRS Power Class	GSM850:Power Class 4/ PCS1900:Power Class 1
GSM/GPRS Operation Frequency	GSM850 :824.2MHz-848.8MHz/PCS1900:1850.2MHz-1909.8MHz
GPRS Operation Frequency Band	GPRS850/GPRS1900
GPRS Multislot Class	Multi-slot Class 12
Extreme temp. Tolerance	-30°C to +50°C
GPRS operation mode	Class B
Antenna Type:	PIFA antenna
Antenna Gain:	GSM850: 1.0 dBi,DCS1900: 1.0 dBi

### 2.3 Equipment under Test

#### Power supply system utilised

Power supply voltage	:	<input type="radio"/> 120V / 60 Hz	<input type="radio"/> 230V / 50Hz
		<input type="radio"/> 12 V DC	<input type="radio"/> 24 V DC
		<input checked="" type="radio"/> Other (specified in blank below)	

DC 3.8V From battery and DC 5.0V From external circuit

#### Test frequency list

Test Mode	TX/RX	RF Channel		
		Low(L)	Middle (M)	High (H)
GPRS 850	TX	Channel 128	Channel 190	Channel 251
		824.2 MHz	836.6 MHz	848.8 MHz
	RX	Channel 128	Channel 190	Channel 251
		869.2 MHz	881.6 MHz	893.8 MHz
Test Mode	TX/RX	RF Channel		
		Low(L)	Middle (M)	High (H)
GPRS 1900	TX	Channel 512	Channel 661	Channel 810
		1850.2 MHz	1880.0 MHz	1909.8 MHz
	RX	Channel 512	Channel 661	Channel 810
		1930.2 MHz	1960.0 MHz	1989.8 MHz

## 2.4 Short description of the Equipment under Test (EUT)

This is a mobile phone.

For more details, refer to the user's manual of the EUT.

## 2.5 EUT configuration

The following peripheral devices and interface cables were connected during the measurement:

- - supplied by the manufacturer
- - supplied by the lab

○ /	M/N :	/
	Manufacturer:	/

## 2.6 Related Submittal(s) / Grant (s)

This submittal(s) (test report) is filing to comply with FCC Part 22 and Part 24 Rules

## 2.7 Modifications

No modifications were implemented to meet testing criteria.

## 2.8 General Test Conditions/Configurations

### 2.8.1 Test Modes

NOTE: The test mode(s) are selected according to relevant radio technology specifications.

Test Mode 1	GSM
Test Mode 2	GPRS

### 2.8.2 Test Environment

Environment Parameter	Selected Values During Tests	
Relative Humidity	Ambient	
Temperature	TN	Ambient
Voltage	VL	3.40V
	VN	3.85V
	VH	4.20V

NOTE: VL=lower extreme test voltage VN=nominal voltage  
VH=upper extreme test voltage TN=normal temperature

## 2.9 Modifications

No modifications were implemented to meet testing criteria.



### 3 TEST ENVIRONMENT

#### 3.1 Address of the test laboratory

**Shenzhen CTA Testing Technology Co., Ltd.**

Room 106, Building 1, Yibaolai Industrial Park, Qiaotou Community, Fuhai Street, Bao'an District, Shenzhen, China

#### 3.2 Test Facility

The test facility is recognized, certified, or accredited by the following organizations:

**FCC-Registration No.: 517856 Designation Number: CN1318**

Shenzhen CTA Testing Technology Co., Ltd. has been listed on the US Federal Communications Commission list of test facilities recognized to perform electromagnetic emissions measurements.

**A2LA-Lab Cert. No.: 6534.01**

Shenzhen CTA Testing Technology Co., Ltd. has been listed by American Association for Laboratory Accreditation to perform electromagnetic emission measurement.

**ISED#: 27890 CAB identifier: CN0127**

Shenzhen CTA Testing Technology Co., Ltd. has been listed by Innovation, Science and Economic Development Canada to perform electromagnetic emission measurement.

The 3m-Semi anechoic test site fulfils CISPR 16-1-4 according to ANSI C63.10 and CISPR 16-1-4:2010.

#### 3.3 Environmental conditions

During the measurement the environmental conditions were within the listed ranges:

Temperature:	15-35 ° C
Humidity:	30-60 %
Atmospheric pressure:	950-1050mbar

#### 3.4 Test Description

##### 3.4.1 Cellular Band (824-849MHz paired with 869-894MHz)

Test Item	FCC Rule No.	Requirements	Verdict
Effective(Isotropic) Radiated Output Power	§2.1046, §22.913	FCC: ERP ≤ 7W.	Pass
Modulation Characteristics	§2.1047	Digital modulation	N/A
Bandwidth	§2.1049	OBW: No limit. EBW: No limit.	Pass
Band Edges Compliance	§2.1051, §22.917	≤-13dBm/1%*EBW, in 1MHz bands immediately outside and adjacent to The frequency block.	Pass
Spurious Emission at Antenna Terminals	§2.1051, §22.917	FCC: ≤ -13dBm/100kHz, from 9kHz to 10th harmonics but outside authorized operating frequency ranges.	Pass
Field Strength of Spurious Radiation	§2.1053, §22.917	FCC: ≤ -13dBm/100kHz.	Pass
Frequency Stability	§2.1055, §22.355	≤ ±2.5ppm.	Pass

NOTE 1: For the verdict, the "N/A" denotes "not applicable", the "N/T" de notes "not tested".

**3.4.2 PCS Band (1850-1915MHz paired with 1930-1995MHz)**

Test Item	FCC Rule No.	Requirements	Verdict
Effective(Isotropic) Radiated Output Power	§2.1046, §24.232	EIRP $\leq$ 2W	Pass
Peak-Average Ratio	§2.1046, §24.232	FCC:Limits $\leq$ 13dB	Pass
Modulation Characteristics	§2.1047	Digital modulation	N/A
Bandwidth	§2.1049	OBW: No limit. EBW: No limit.	Pass
Band Edges Compliance	§2.1051, §24.238	$\leq$ -13dBm/1%*EBW, In 1MHz bands immediately outside and adjacent to The frequency block.	Pass
Spurious Emission at Antenna Terminals	§2.1051, §24.238	$\leq$ -13dBm/1MHz, from 9kHz to10th harmonics but outside authorized Operating frequency ranges.	Pass
Field Strength of Spurious Radiation	§2.1053, §24.238	$\leq$ -13dBm/1MHz.	Pass
Frequency Stability	§2.1055, §24.235	FCC: within authorized frequency block.	Pass

NOTE 1: For the verdict, the "N/A" denotes "not applicable", the "N/T" de notes "not tested".

Remark:

1. The measurement uncertainty is not included in the test result.



### 3.5 Equipments Used during the Test

Test Equipment	Manufacturer	Model No.	Equipment No.	Calibration Date	Calibration Due Date
LISN	R&S	ENV216	CTA-308	2023/08/02	2024/08/01
LISN	R&S	ENV216	CTA-314	2023/08/02	2024/08/01
EMI Test Receiver	R&S	ESPI	CTA-307	2023/08/02	2024/08/01
EMI Test Receiver	R&S	ESCI	CTA-306	2023/08/02	2024/08/01
Spectrum Analyzer	Agilent	N9020A	CTA-301	2023/08/02	2024/08/01
Spectrum Analyzer	R&S	FSP	CTA-337	2023/08/02	2024/08/01
Vector Signal generator	Agilent	N5182A	CTA-305	2023/08/02	2024/08/01
Analog Signal Generator	R&S	SML03	CTA-304	2023/08/02	2024/08/01
Universal Radio Communication	CMW500	R&S	CTA-302	2023/08/02	2024/08/01
Temperature and humidity meter	Chigo	ZG-7020	CTA-326	2023/08/02	2024/08/01
Ultra-Broadband Antenna	Schwarzbeck	VULB9163	CTA-310	2021/08/07	2024/08/06
Horn Antenna	Schwarzbeck	BBHA 9120D	CTA-309	2021/08/07	2024/08/06
Loop Antenna	Zhinan	ZN30900C	CTA-311	2021/08/07	2024/08/06
Horn Antenna	Beijing Hangwei Dayang	OBH100400	CTA-336	2021/08/07	2024/08/06
Amplifier	Schwarzbeck	BBV 9745	CTA-312	2023/08/02	2024/08/01
Amplifier	Taiwan chengyi	EMC051845B	CTA-313	2023/08/02	2024/08/01
Directional coupler	NARDA	4226-10	CTA-303	2023/08/02	2024/08/01
High-Pass Filter	XingBo	XBLBQ-GTA18	CTA-402	2023/08/02	2024/08/01
High-Pass Filter	XingBo	XBLBQ-GTA27	CTA-403	2023/08/02	2024/08/01
Automated filter bank	Tonscend	JS0806-F	CTA-404	2023/08/02	2024/08/01
Power Sensor	Agilent	U2021XA	CTA-405	2023/08/02	2024/08/01
Amplifier	Schwarzbeck	BBV9719	CTA-406	2023/08/02	2024/08/01

Test Equipment	Manufacturer	Model No.	Version number	Calibration Date	Calibration Due Date
EMI Test Software	Tonscend	TS@JS32-RE	5.0.0.2	N/A	N/A
EMI Test Software	Tonscend	TS@JS32-CE	5.0.0.1	N/A	N/A
RF Test Software	Tonscend	TS@JS1120-3	3.1.65	N/A	N/A
RF Test Software	Tonscend	TS@JS1120	3.1.46	N/A	N/A

## 4 TEST CONDITIONS AND RESULTS

### 4.1 Output Power

#### TEST APPLICABLE

During the process of testing, the EUT was controlled via R&S Digital Radio Communication tester (CMW500) to ensure max power transmission and proper modulation. This result contains output power and EIRP measurements for the EUT. In all cases, output power is within the specified limits.

#### 4.1.1 Conducted Output Power

#### TEST CONFIGURATION

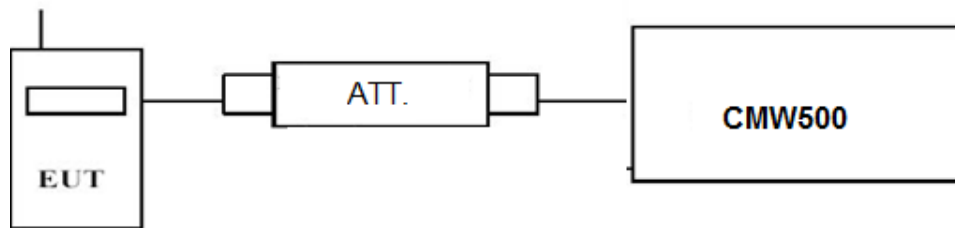

#### TEST PROCEDURE

##### Conducted Power Measurement:

- Place the EUT on a bench and set it in transmitting mode.
- Connect a low loss RF cable from the antenna port to a CMW500 by an Att.
- EUT Communicate with CMW500 then selects a channel for testing.
- Add a correction factor to the display CMW500, and then test.

GSM850				
Function	Power step	Nominal output power (dBm)	Power & Multislot class	Operation class
GSM	5	33dBm(2W)	4	/
GPRS	3	33dBm(2W)	12	B

PCS1900				
Function	Power step	Nominal output power (dBm)	Power & Multislot class	Operation class
GSM	0	30dBm(1W)	1	/
GPRS	3	30dBm(1W)	12	B

#### TEST RESULTS

GSM 850		Burst Average Conducted power (dBm)		
		Channel/Frequency(MHz)		
		128/824.2	190/836.6	251/848.8
GSM		31.99	32.54	32.68
GPRS (GMSK)	1TX slot	31.92	32.48	32.50
	2TX slot	29.33	29.75	29.36
	3TX slot	27.72	26.95	26.70
	4TX slot	25.91	26.67	26.64
GSM 1900		Burst Average Conducted power (dBm)		
		Channel/Frequency(MHz)		
		512/1850.2	661/1880.0	810/1909.8
GSM		30.15	30.24	29.70
GPRS (GMSK)	1TX slot	29.90	29.87	30.55
	2TX slot	27.41	26.86	26.81
	3TX slot	25.36	25.75	25.03
	4TX slot	24.76	24.22	24.38

## 4.1.2 Radiated Output Power

### TEST DESCRIPTION

This is the test for the maximum radiated power from the EUT.

Rule Part 24.232(c) specifies, "Mobile/portable stations are limited to 2 watts e.i.r.p. Peak power" and 24.232(e) specifies that "Peak transmit power must be measured over any interval of continuous transmission using instrumentation calibrated in terms of an rms-equivalent voltage." Rule Part 22.913(a) specifies "The ERP of mobile transmitters and auxiliary test transmitters must not exceed 7 Watts."

### TEST CONFIGURATION

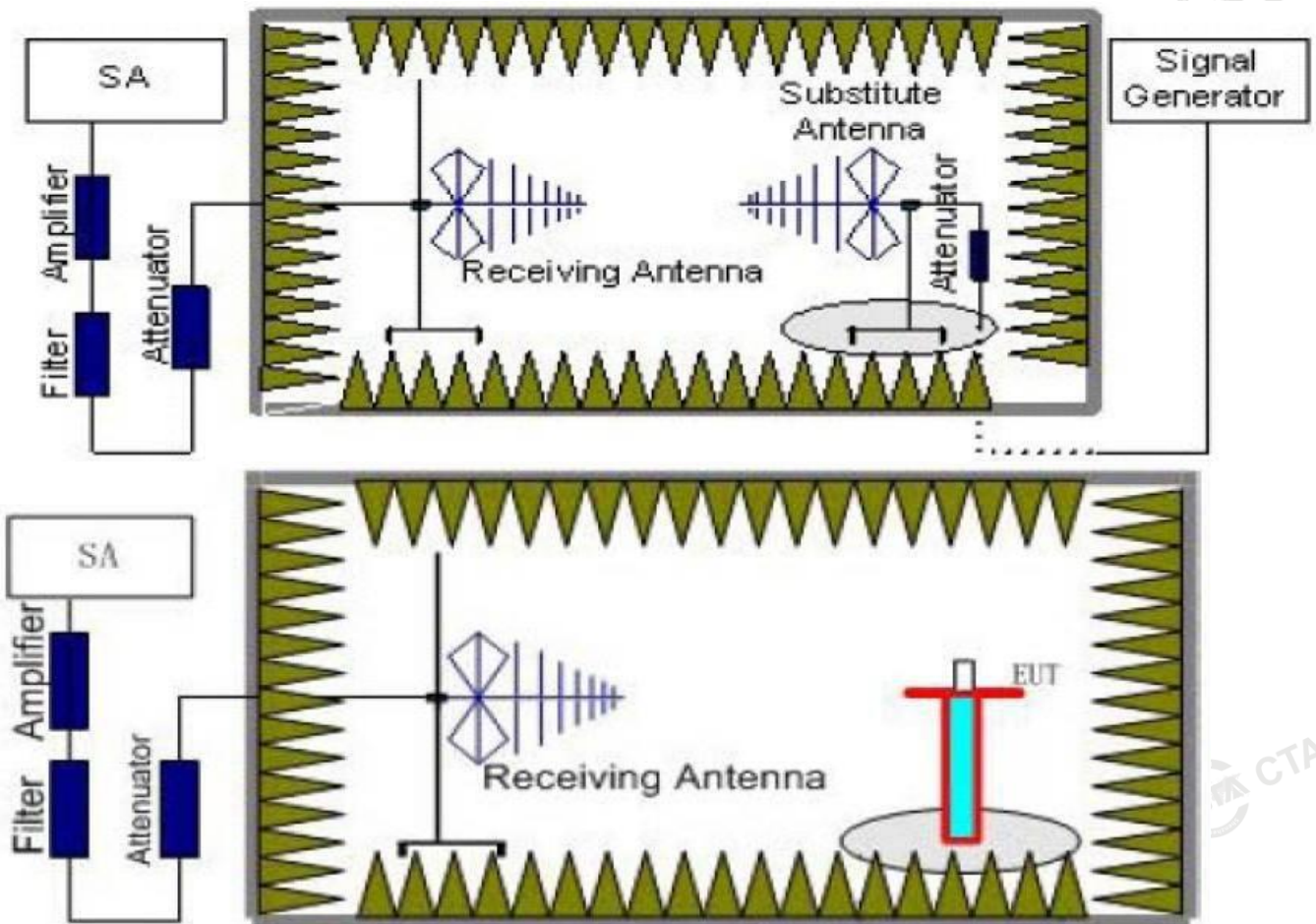

### TEST PROCEDURE

1. EUT was placed on a 0.80 meter high non-conductive stand at a 3 meter test distance from the receive antenna. A receiving antenna was placed on the antenna mast 3 meters from the EUT for emission measurements. The height of receiving antenna is 0.80m. Detected emissions were maximized at each frequency by rotating the EUT through 360° and adjusting the receiving antenna polarization. The radiated emission measurements of all transmit frequencies in three channels (High, Middle, Low) were measured with peak detector.
2. A log-periodic antenna or double-ridged waveguide horn antenna shall be substituted in place of the EUT. The log-periodic antenna will be driven by a signal generator and the level will be adjusted till the same power value on the spectrum analyzer or receiver. The level of the spurious emissions can be calculated through the level of the signal generator, cable loss, the gain of the substitution antenna and the reading of the spectrum analyzer or receiver.
3. The EUT is then put into continuously transmitting mode at its maximum power level during the test. Set Test Receiver or Spectrum RBW=1MHz, VBW=3MHz, And the maximum value of the receiver should be recorded as ( $P_r$ ).
4. The EUT shall be replaced by a substitution antenna. In the chamber, an substitution antenna for the frequency band of interest is placed at the reference point of the chamber. An RF Signal source for the frequency band of interest is connected to the substitution antenna with a cable that has been constructed to not interfere with the radiation pattern of the antenna. A power ( $P_{Mea}$ ) is applied to the input of the

substitution antenna, and adjust the level of the signal generator output until the value of the receiver reach the previously recorded ( $P_r$ ). The power of signal source ( $P_{Mea}$ ) is recorded. The test should be performed by rotating the test item and adjusting the receiving antenna polarization.

5. A amplifier should be connected to the Signal Source output port. And the cable should be connect between the Amplifier and the Substitution Antenna. The cable loss ( $P_{cl}$ ), the Substitution Antenna Gain ( $G_a$ ) and the Amplifier Gain ( $P_{Ag}$ ) should be recorded after test.

The measurement results are obtained as described below:

$$\text{Power(EIRP)} = P_{Mea} - P_{Ag} - P_{cl} + G_a$$

We used SMF100A micowave signal generator which signal level can up to 33dBm,so we not used power Amplifier for substitution test; The measurement results are amend as described below:

$$\text{Power(EIRP)} = P_{Mea} - P_{cl} + G_a$$

6. This value is EIRP since the measurement is calibrated using an antenna of known gain (2.15 dBi) and known input power.
7. ERP can be calculated from EIRP by subtracting the gain of the dipole,  $ERP = EIRP - 2.15\text{dBi}$ .

**TEST LIMIT**

Note: We test the H direction and V direction, V direction is worse.

According to 22.913(a) and 24.232(c), the ERP should be not exceed following table limits:

GSM850(GPRS850,EDGE850)		
Function	Power Step	Burst Peak ERP (dBm)
GSM	5	≤38.45dBm (7W)
GPRS	3	≤38.45dBm (7W)

PCS1900(GPRS1900,EDGE1900)		
Function	Power Step	Burst Peak EIRP (dBm)
GSM	0	≤33dBm (2W)
GPRS	3	≤33dBm (2W)

**TEST RESULTS**

Remark:

1. We were tested all Configuration refer 3GPP TS151 010.
2.  $EIRP = P_{Mea}(\text{dBm}) - P_{cl}(\text{dB}) + P_{Ag}(\text{dB}) + G_a(\text{dBi})$
3.  $ERP = EIRP - 2.15\text{dBi}$  as EIRP by subtracting the gain of the dipole.

Note: We tesed Horizontal and Vertical, and Recorded the worst data at the Vertical

**GSM 850**

Frequency (MHz)	$P_{Mea}$ (dBm)	$P_{cl}$ (dB)	$G_a$ Antenna Gain(dB)	Correction (dB)	$P_{Ag}$ (dB)	ERP (dBm)	Limit (dBm)	Margin (dB)	Polarization
824.20	-9.30	2.42	8.45	2.15	36.82	31.40	38.45	-7.05	V
836.60	-9.44	2.46	8.45	2.15	36.82	31.22	38.45	-7.23	V
848.80	-8.84	2.53	8.36	2.15	36.82	31.66	38.45	-6.79	V

**GSM 1900**

Frequency (MHz)	$P_{Mea}$ (dBm)	$P_{cl}$ (dB)	$G_a$ Antenna Gain(dB)	$P_{Ag}$ (dB)	EIRP (dBm)	Limit (dBm)	Margin (dB)	Polarization
1850.20	-11.61	3.41	10.24	33.6	28.82	33.01	-4.19	V
1880.00	-12.44	3.49	10.24	33.6	27.91	33.01	-5.10	V
1909.80	-12.24	3.55	10.23	33.6	28.04	33.01	-4.97	V



## GPRS 850

Frequency (MHz)	P <sub>Mea</sub> (dBm)	P <sub>cl</sub> (dB)	G <sub>a</sub> Antenna Gain(dB)	Correction (dB)	P <sub>Ag</sub> (dB)	ERP (dBm)	Limit (dBm)	Margin (dB)	Polarization
824.20	-8.54	2.42	8.45	2.15	36.82	32.16	38.45	-6.29	V
836.60	-7.43	2.46	8.45	2.15	36.82	33.23	38.45	-5.22	V
848.80	-8.11	2.53	8.36	2.15	36.82	32.39	38.45	-6.06	V

## GPRS 1900

Frequency (MHz)	P <sub>Mea</sub> (dBm)	P <sub>cl</sub> (dB)	G <sub>a</sub> Antenna Gain(dB)	P <sub>Ag</sub> (dB)	EIRP (dBm)	Limit (dBm)	Margin (dB)	Polarization
1850.20	-12.66	3.41	10.24	33.6	27.77	33.01	-5.24	V
1880.00	-12.60	3.49	10.24	33.6	27.75	33.01	-5.26	V
1909.80	-12.74	3.55	10.23	33.6	27.54	33.01	-5.47	V



## 4.2 Radiated Spurious Emission

### TEST APPLICABLE

According to the TIA/EIA 603D:2010 test method, The Receiver or Spectrum was scanned from 30 MHz to the 10th harmonic of the highest frequency generated within the equipment, which is the transmitted carrier that can be as high as 1910 MHz. The resolution bandwidth is set as outlined in Part 24.238 and Part 22.917. The spectrum is scanned with the mobile station transmitting at carrier frequencies that pertain to low, mid and high channels of PCS1900 and GSM850.

### TEST CONFIGURATION

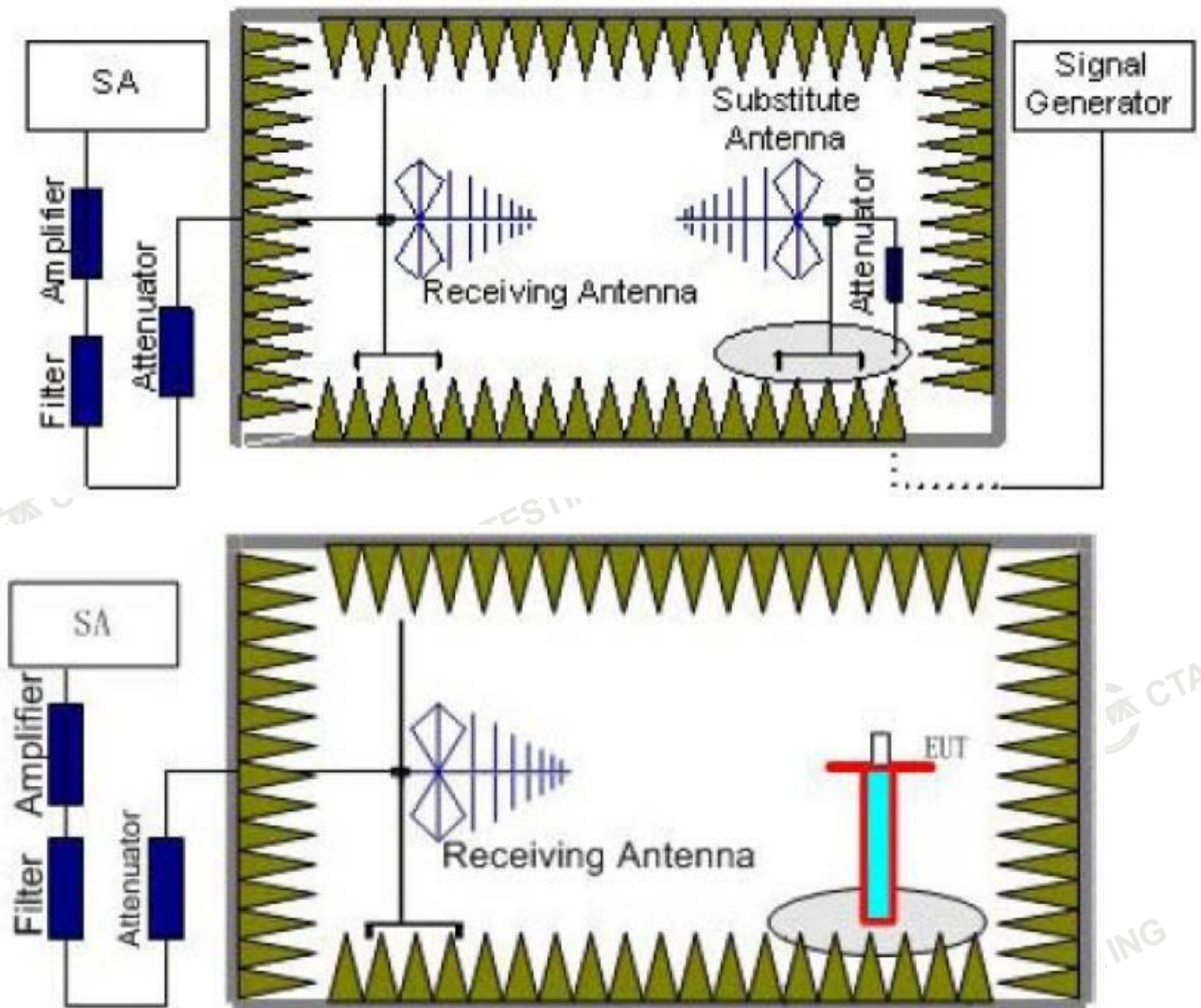

### TEST PROCEDURE

1. EUT was placed on a 0.80 meter high non-conductive stand at a 3 meter test distance from the receive antenna. A receiving antenna was placed on the antenna mast 3 meters from the EUT for emission measurements. The height of receiving antenna is 0.80m. Detected emissions were maximized at each frequency by rotating the EUT through 360° and adjusting the receiving antenna polarization. The radiated emission measurements of all transmit frequencies in three channels (High, Middle, Low) were measured with peak detector.
2. A log-periodic antenna or double-ridged waveguide horn antenna shall be substituted in place of the EUT. The log-periodic antenna will be driven by a signal generator and the level will be adjusted till the same power value on the spectrum analyzer or receiver. The level of the spurious emissions can be calculated through the level of the signal generator, cable loss, the gain of the substitution antenna and the reading of the spectrum analyzer or receiver.

- The EUT is then put into continuously transmitting mode at its maximum power level during the test. Set Test Receiver or Spectrum RBW=1MHz, VBW=3MHz, And the maximum value of the receiver should be recorded as (P<sub>r</sub>).
- The EUT shall be replaced by a substitution antenna. In the chamber, an substitution antenna for the frequency band of interest is placed at the reference point of the chamber. An RF Signal source for the frequency band of interest is connected to the substitution antenna with a cable that has been constructed to not interfere with the radiation pattern of the antenna. A power (P<sub>Mea</sub>) is applied to the input of the substitution antenna, and adjust the level of the signal generator output until the value of the receiver reach the previously recorded (P<sub>r</sub>). The power of signal source (P<sub>Mea</sub>) is recorded. The test should be performed by rotating the test item and adjusting the receiving antenna polarization.
- A amplifier should be connected to the Signal Source output port. And the cable should be connect between the Amplifier and the Substitution Antenna. The cable loss (P<sub>cl</sub>), the Substitution Antenna Gain (G<sub>a</sub>) and the Amplifier Gain (P<sub>Ag</sub>) should be recorded after test.

The measurement results are obtained as described below:

$$\text{Power(EIRP)} = P_{\text{Mea}} - P_{\text{Ag}} - P_{\text{cl}} + G_a$$

- This value is EIRP since the measurement is calibrated using an antenna of known gain (2.15 dBi) and known input power.
- ERP can be calculated from EIRP by subtracting the gain of the dipole, ERP = EIRP -2.15dBi.
- In order to make sure test results more clearly, we set frequency range and sweep time for difference frequency range as follows table:

Working Frequency	Subrange (GHz)	RBW	VBW	Sweep time (s)
GSM 850	0.00009~0.15	1KHz	3KHz	30
	0.00015~0.03	10KHz	30KHz	10
	0.03~1	100KHz	300KHz	10
	1~2	1 MHz	3 MHz	2
	2~5	1 MHz	3 MHz	3
	5~8	1 MHz	3 MHz	3
	8~10	1 MHz	3 MHz	3
PCS 1900	0.00009~0.15	1KHz	3KHz	30
	0.00015~0.03	10KHz	30KHz	10
	0.03~1	100KHz	300KHz	10
	1~2	1 MHz	3 MHz	2
	2~5	1 MHz	3 MHz	3
	5~8	1 MHz	3 MHz	3
	8~11	1 MHz	3 MHz	3
	11~14	1 MHz	3 MHz	3
	14~18	1 MHz	3 MHz	3
18~20	1 MHz	3 MHz	2	

**TEST LIMITS**

According to 24.238 and 22.917 specify that the power of any emission outside of the authorized operating frequency ranges must be attenuated below the transmitting power (P) by a factor of at least 43 + 10 log(P) dB.

The specification that emissions shall be attenuated below the transmitter power (P) by at least 43 + 10 log (P) dB, translates in the relevant power range (1 to 0.001 W) to -13 dBm. At 1 W the specified minimum attenuation becomes 43 dB and relative to a 30 dBm (1 W) carrier becomes a limit of -13 dBm. At 0.001 W (0 dBm) the minimum attenuation is 13 dB, which again yields a limit of -13 dBm. In this way a translation of the specification from relative to absolute terms is carried out.

Frequency	Channel	Frequency Range	Verdict
GSM 850	Low	9KHz-10GHz	PASS
	Middle	9KHz -10GHz	PASS
	High	9KHz -10GHz	PASS
PCS 1900	Low	9KHz -20GHz	PASS
	Middle	9KHz -20GHz	PASS
	High	9KHz -20GHz	PASS

**TEST RESULTS**

Remark:

1. We were tested all refer 3GPP TS151 010.
2.  $EIRP = P_{Mea}(dBm) - P_{cl}(dB) + G_a(dBi)$
3. We were not recorded other points as values lower than limits.
4. Margin = Limit - EIRP

Note : We tested GSM and GPRS Mode, and recorded the worst case at the GSM Mode

#### GSM850\_ Low Channel

Frequency (MHz)	P <sub>Mea</sub> (dBm)	P <sub>cl</sub> (dB)	Diatance	G <sub>a</sub> Antenna Gain(dB)	EIRP (dBm)	Limit (dBm)	Margin (dB)	Polarization
1648.4	-44.28	3.00	3.00	9.58	-37.70	-13.00	-24.70	H
2472.6	-48.35	3.03	3.00	10.72	-40.66	-13.00	-27.66	H
1648.4	-42.69	3.00	3.00	9.68	-36.01	-13.00	-23.01	V
2472.6	-53.34	3.03	3.00	10.72	-45.65	-13.00	-32.65	V

#### GSM850\_ Middle Channel

Frequency (MHz)	P <sub>Mea</sub> (dBm)	P <sub>cl</sub> (dB)	Diatance	G <sub>a</sub> Antenna Gain(dB)	EIRP (dBm)	Limit (dBm)	Margin (dB)	Polarization
1673.2	-42.56	3.00	3.00	9.58	-35.98	-13.00	-22.98	H
2509.8	-46.67	3.03	3.00	10.72	-38.98	-13.00	-25.98	H
1673.2	-45.21	3.00	3.00	9.68	-38.53	-13.00	-25.53	V
2509.8	-49.94	3.03	3.00	10.72	-42.25	-13.00	-29.25	V

#### GSM850\_ High Channel

Frequency (MHz)	P <sub>Mea</sub> (dBm)	P <sub>cl</sub> (dB)	Diatance	G <sub>a</sub> Antenna Gain(dB)	EIRP (dBm)	Limit (dBm)	Margin (dB)	Polarization
1697.6	-42.89	3.00	3.00	9.58	-36.31	-13.00	-23.31	H
2546.4	-51.92	3.03	3.00	10.72	-44.23	-13.00	-31.23	H
1697.6	-42.85	3.00	3.00	9.68	-36.17	-13.00	-23.17	V
2546.4	-46.70	3.03	3.00	10.72	-39.01	-13.00	-26.01	V

#### GSM1900\_ Low Channel

Frequency (MHz)	P <sub>Mea</sub> (dBm)	P <sub>cl</sub> (dB)	Diatance	G <sub>a</sub> Antenna Gain(dB)	Peak EIRP (dBm)	Limit (dBm)	Margin (dB)	Polarization
3700.4	-45.67	4.39	3.00	12.34	-37.72	-13.00	-24.72	H
5550.6	-49.54	5.31	3.00	13.52	-41.33	-13.00	-28.33	H
3700.4	-43.72	4.39	3.00	12.34	-35.77	-13.00	-22.77	V
5550.6	-50.05	5.31	3.00	13.52	-41.84	-13.00	-28.84	V

#### GSM1900\_ Middle Channel

Frequency (MHz)	P <sub>Mea</sub> (dBm)	P <sub>cl</sub> (dB)	Diatance	G <sub>a</sub> Antenna Gain(dB)	EIRP (dBm)	Limit (dBm)	Margin (dB)	Polarization
3760.0	-41.71	4.41	3.00	12.34	-33.78	-13.00	-20.78	H
5640.0	-48.71	5.38	3.00	13.58	-40.51	-13.00	-27.51	H
3760.0	-40.26	4.41	3.00	12.34	-32.33	-13.00	-19.33	V
5640.0	-47.76	5.38	3.00	13.58	-39.56	-13.00	-26.56	V

#### GSM1900\_ High Channel

Frequency (MHz)	P <sub>Mea</sub> (dBm)	P <sub>cl</sub> (dB)	Diatance	G <sub>a</sub> Antenna Gain(dB)	EIRP (dBm)	Limit (dBm)	Margin (dB)	Polarization
3819.6	-40.27	4.45	3.00	12.45	-32.27	-13.00	-19.27	H
5729.4	-55.69	5.47	3.00	13.66	-47.50	-13.00	-34.50	H
3819.6	-44.17	4.45	3.00	12.45	-36.17	-13.00	-23.17	V
5729.4	-47.45	5.48	3.00	13.66	-39.27	-13.00	-26.27	V

### 4.3 Occupied Bandwidth and Emission Bandwidth

#### TEST APPLICABLE

Similar to conducted emissions; occupied bandwidth measurements are only provided for selected frequencies in order to reduce the amount of submitted data. Data were taken at the extreme and mid frequencies of PCS1900 band and GSM850 band. The table below lists the measured 99% Bandwidth and -26dBc Bandwidth.

#### TEST CONFIGURATION

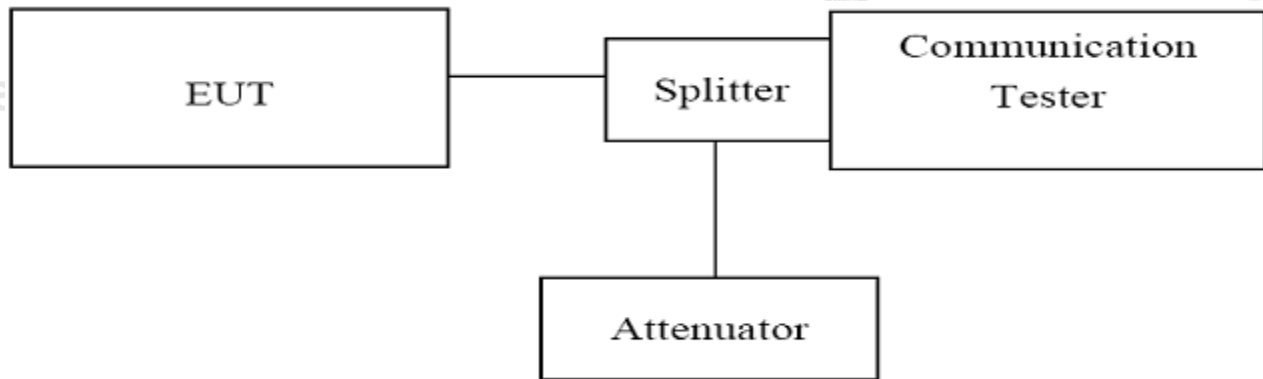

#### TEST PROCEDURE

1. The EUT was set up for the max output power with pseudo random data modulation;
2. The Occupied bandwidth and Emission Bandwidth were measured with Agilent Spectrum Analyzer N9030A (peak);
3. Set RBW=5.1KHz, VBW=51KHz, Span=1MHz, SWT=500ms;
4. Set SPA Max hold and View, Set 99% Occupied Bandwidth/ Set -26dBc Occupied Bandwidth
5. These measurements were done at 3 frequencies, 1850.20 MHz, 1880.00 MHz and 1909.80 MHz for PCS1900 band; 824.20MHz, 836.60 MHz and 848.80 MHz for GSM850 band. (Low, middle and high of operational frequency range).

#### TEST RESULTS

GSM 850				
Channel Number	Frequency (MHz)	Occupied Bandwidth (99% BW) ( MHz)	Emission Bandwidth (26 dBc BW) ( MHz)	Verdict
128	824.20	0.24464	0.314	PASS
190	836.60	0.24693	0.3153	PASS
251	848.80	0.24736	0.3098	PASS

  

GSM 1900				
Channel Number	Frequency (MHz)	Occupied Bandwidth (99% BW) ( MHz)	Emission Bandwidth (26 dBc BW) ( MHz)	Verdict
512	1850.20	0.24559	0.3062	PASS
661	1880.00	0.24639	0.3146	PASS
810	1909.80	0.24678	0.3155	PASS



GPRS 850				
Channel Number	Frequency (MHz)	Occupied Bandwidth (99% BW) ( MHz)	Emission Bandwidth (26 dBc BW) ( MHz)	Verdict
128	824.20	0.24275	0.3031	PASS
190	836.60	0.24564	0.3152	PASS
251	848.80	0.24954	0.3161	PASS

GPRS 1900				
Channel Number	Frequency (MHz)	Occupied Bandwidth (99% BW) ( MHz)	Emission Bandwidth (26 dBc BW) ( MHz)	Verdict
512	1850.20	0.24722	0.31	PASS
661	1880.00	0.24467	0.3114	PASS
810	1909.80	0.2456	0.3131	PASS

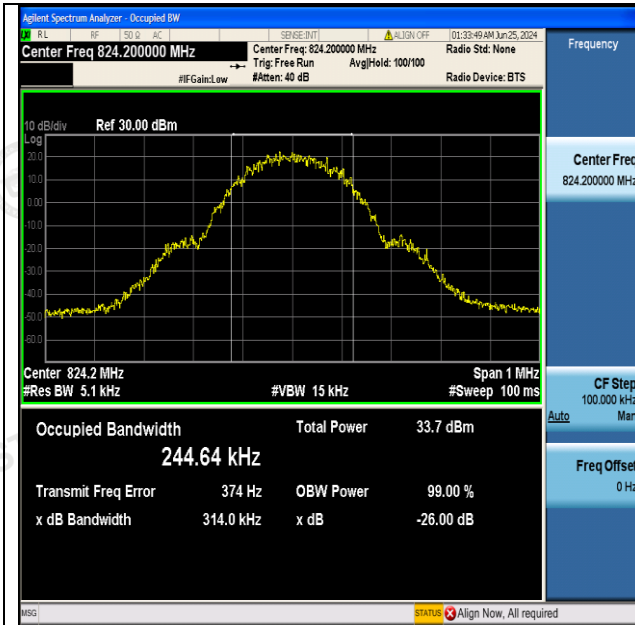

GSM850-128-5-PASS

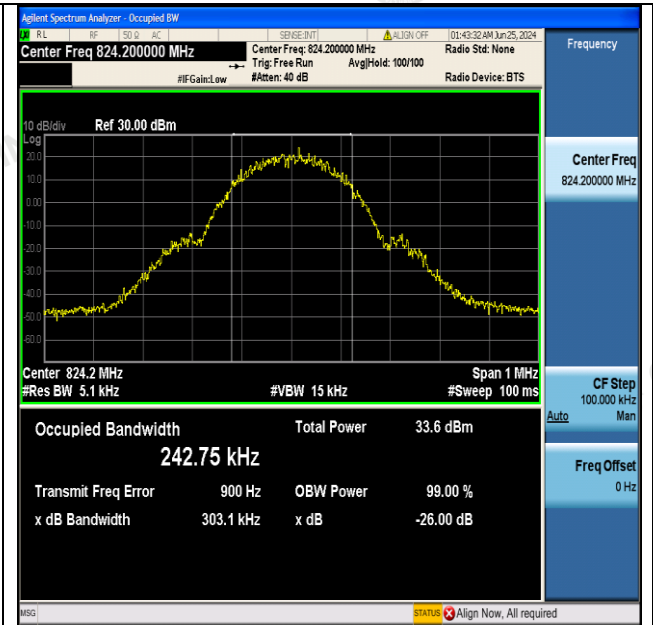

GPRS850-128-5-PASS

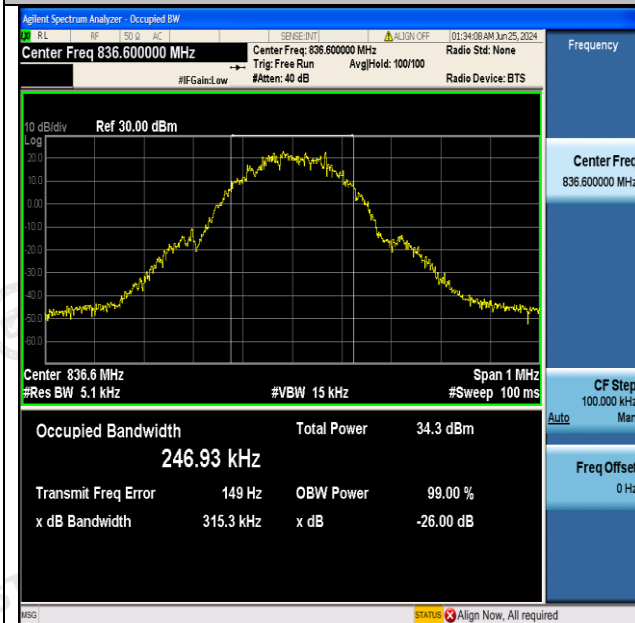

GSM850-190-5-PASS

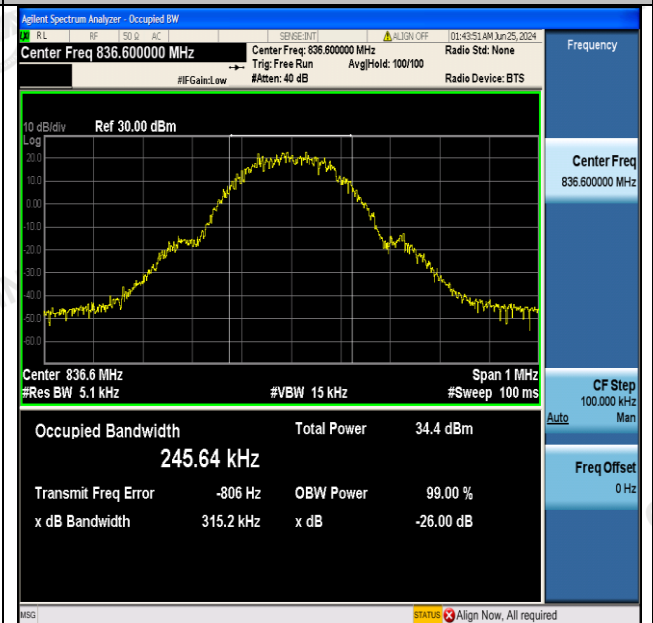

GPRS850-190-5-PASS

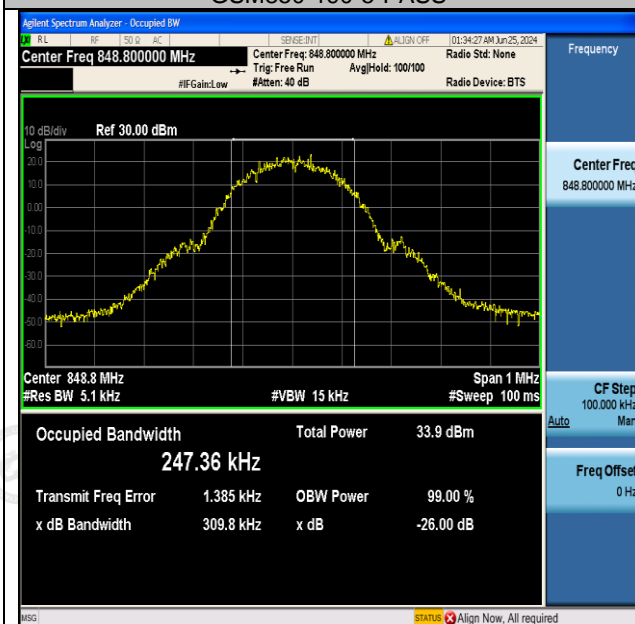

GSM850-251-5-PASS

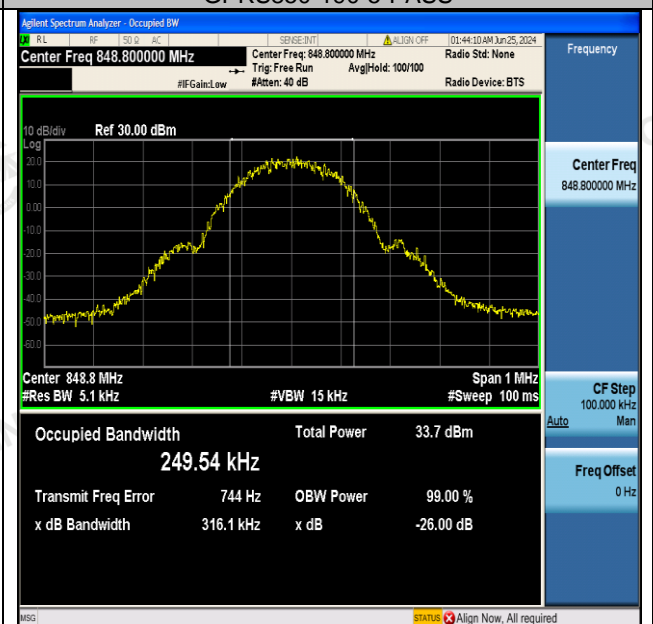

GPRS850-251-5-PASS



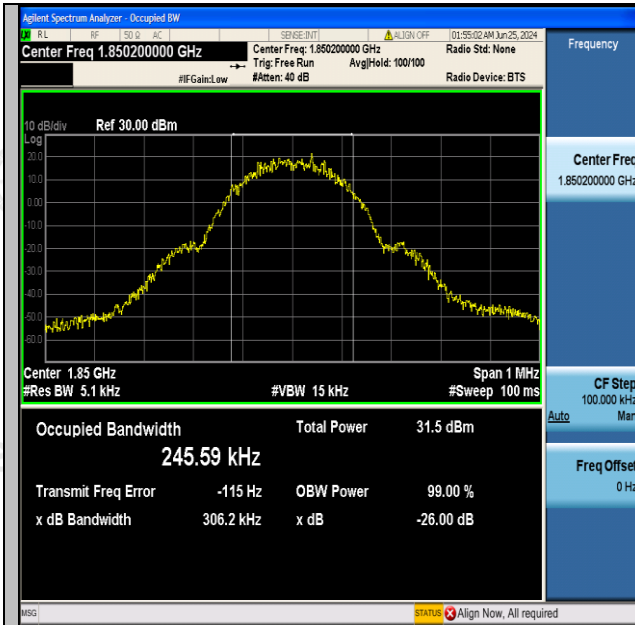

GSM1900-512-0-PASS

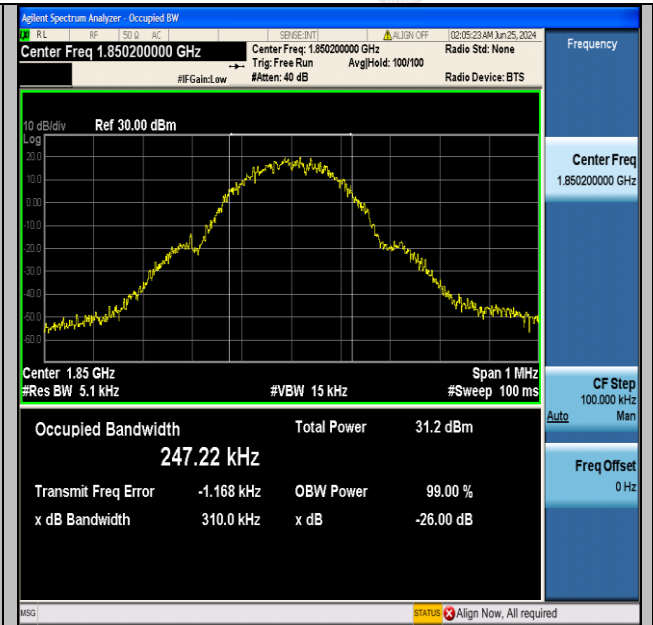

GPRS1900-512-0-PASS

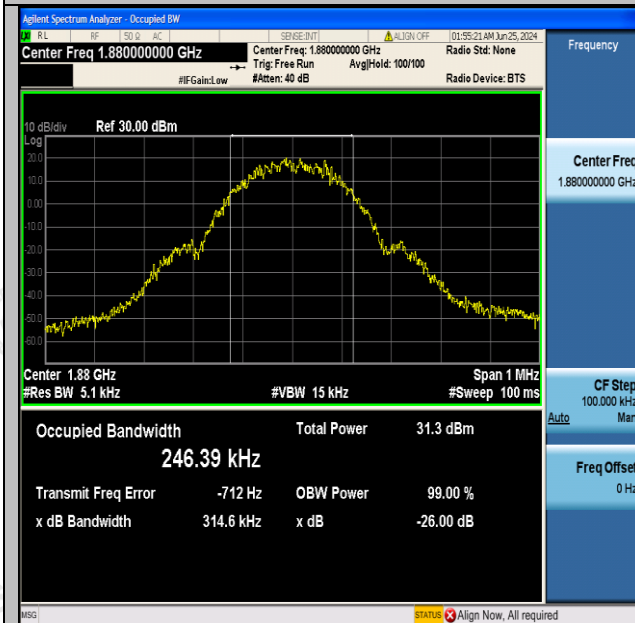

GSM1900-661-0-PASS

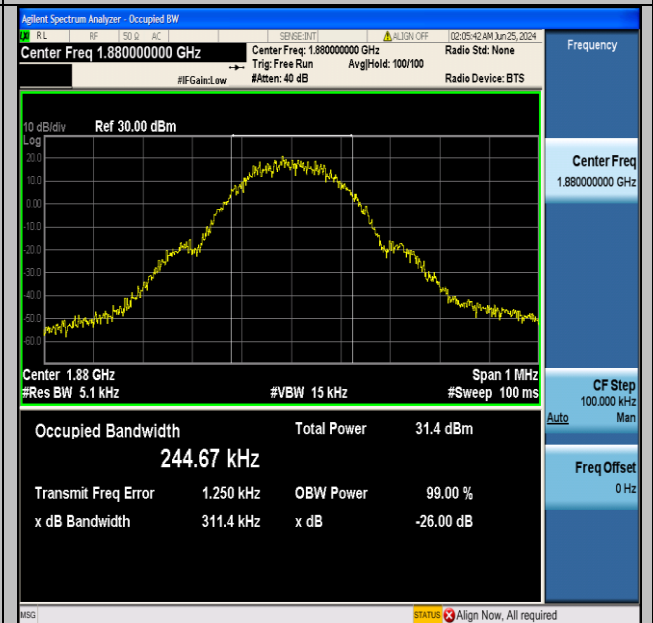

GPRS1900-661-0-PASS

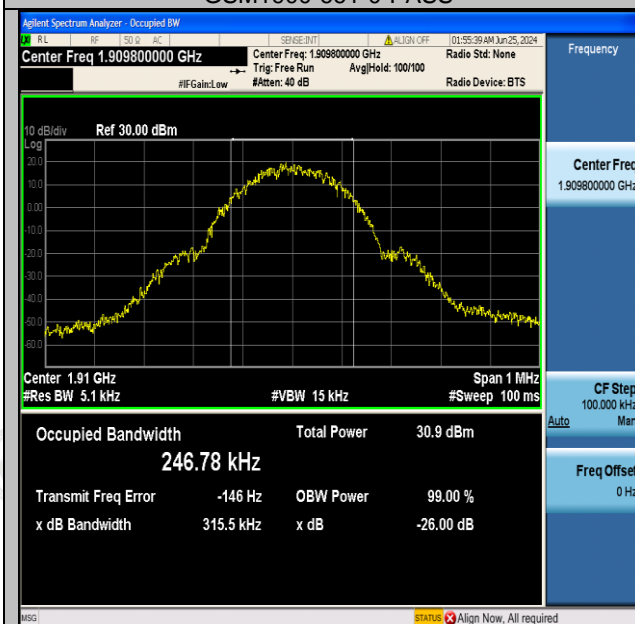

GSM1900-810-0-PASS

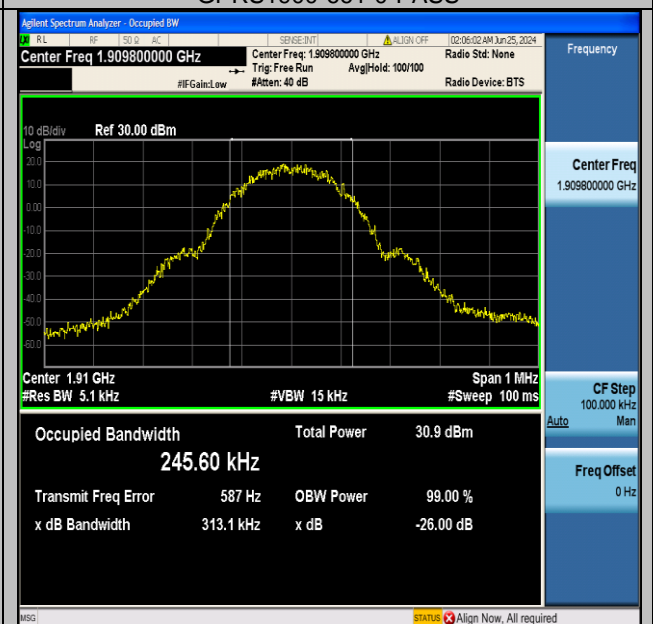

GPRS1900-810-0-PASS

#### 4.4 Band Edge Compliance

##### TEST APPLICABLE

During the process of testing, the EUT was controlled via Agilent Digital Radio Communication tester (CMW500) to ensure max power transmission and proper modulation.

##### TEST CONFIGURATION

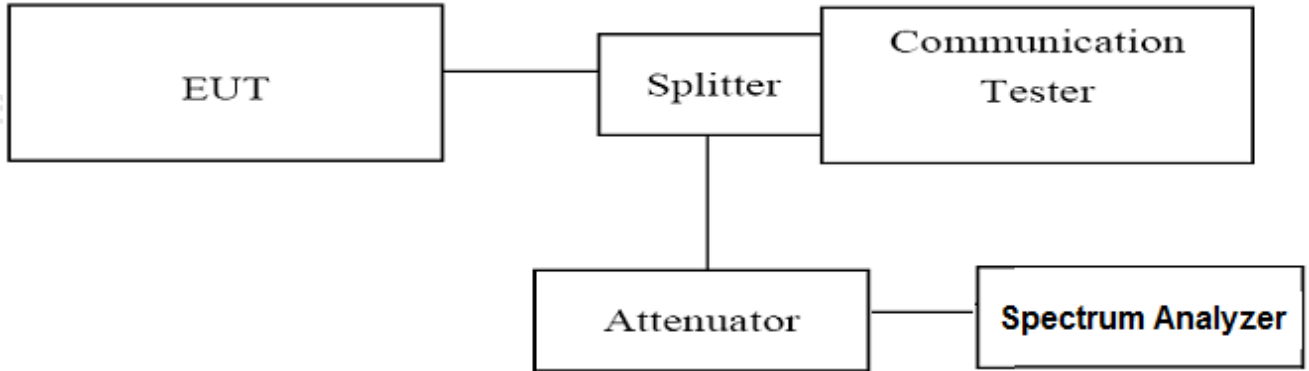

##### TEST PROCEDURE

1. The EUT was set up for the max output power with pseudo random data modulation;
2. The power was measured with Agilent Spectrum Analyzer N9030A;
3. Set RBW=5.1KHz, VBW=51KHz, Span=3MHz, SWT=300ms, Dector: RMS;
4. These measurements were done at 3 frequencies, 1850.20 MHz, 1880.00 MHz and 1909.80 MHz for PCS1900 band; 824.20 MHz, 836.60 MHz and 848.80 MHz for GSM850 band. (bottom, middle and top of operational frequency range).

##### TEST RESULTS

Band	Channel	Freq (MHz)	Result (dBm)	Limit(dBm)	Verdict
GSM850	128	823.98	-30.33	-13	PASS
GPRS850	128	824.00	-28.19	-13	PASS
GSM850	251	849.02	-29.51	-13	PASS
GPRS850	251	849.02	-26.76	-13	PASS

Band	Channel	Freq (MHz)	Result (dBm)	Limit(dBm)	Verdict
GSM1900	512	1850.00	-31.48	-13	PASS
GPRS1900	512	1849.97	-32.52	-13	PASS
GSM1900	810	1910.02	-32.79	-13	PASS
GPRS1900	810	1910.02	-32.73	-13	PASS

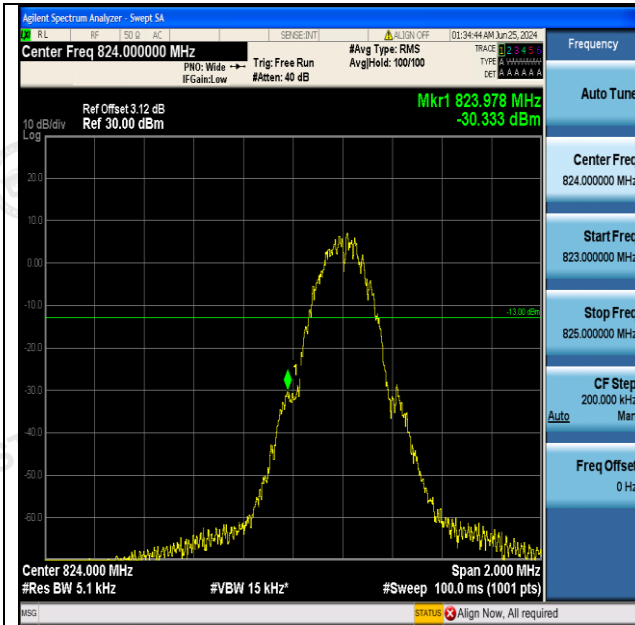

GSM850-128-5-PASS

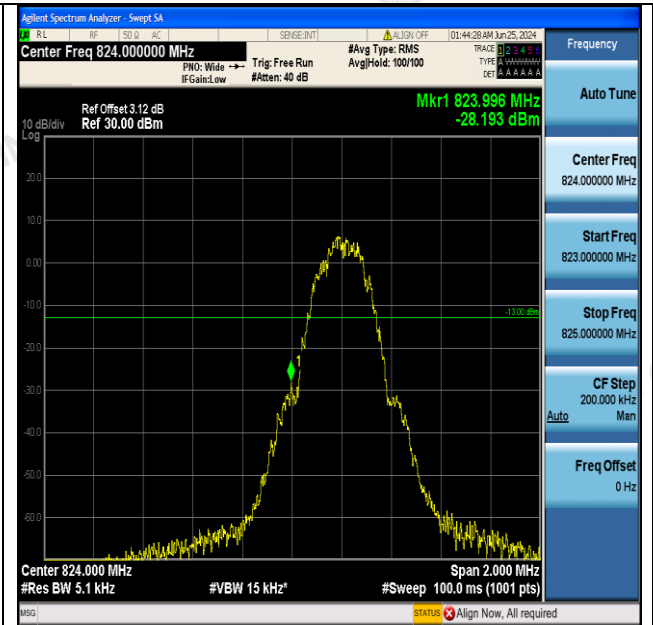

GPRS850-128-5-PASS

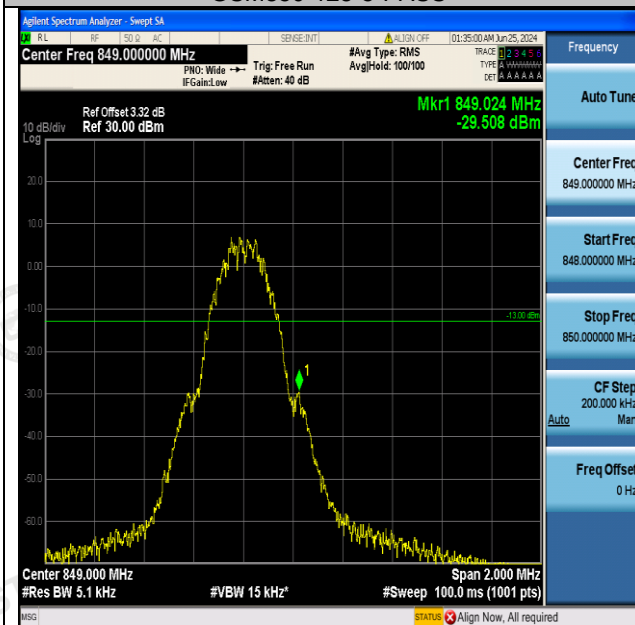

GSM850-251-5-PASS

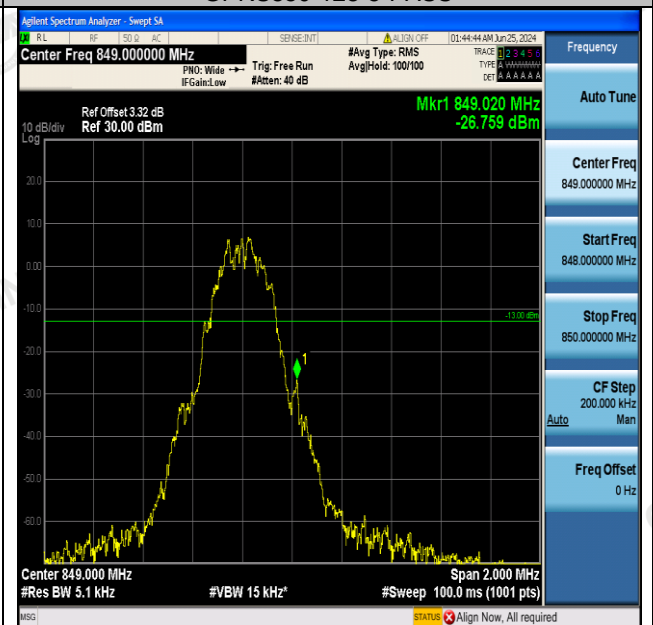

GPRS850-251-5-PASS

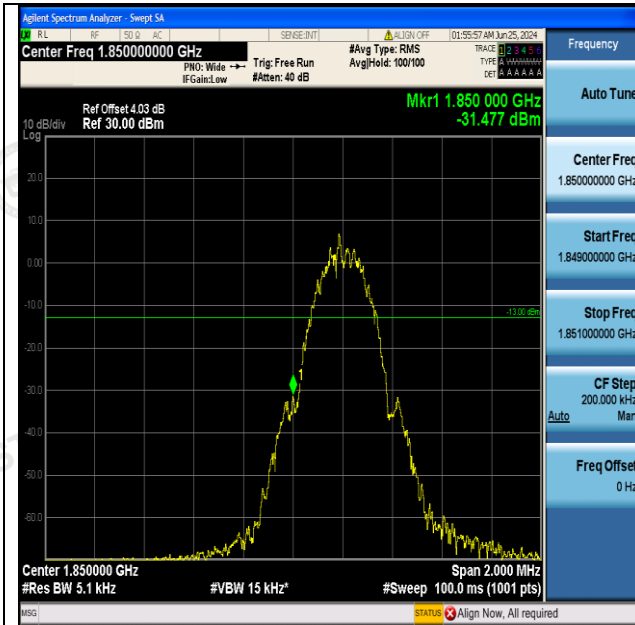

GSM1900-512-0-PASS

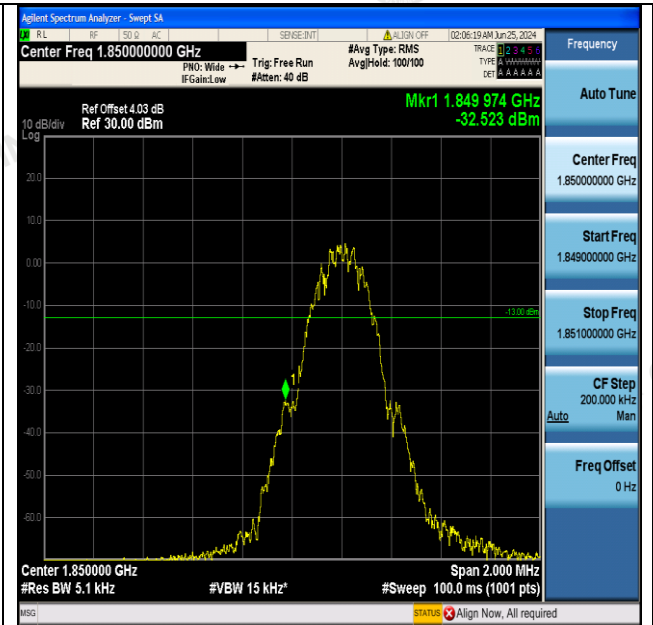

GPRS1900-512-0-PASS

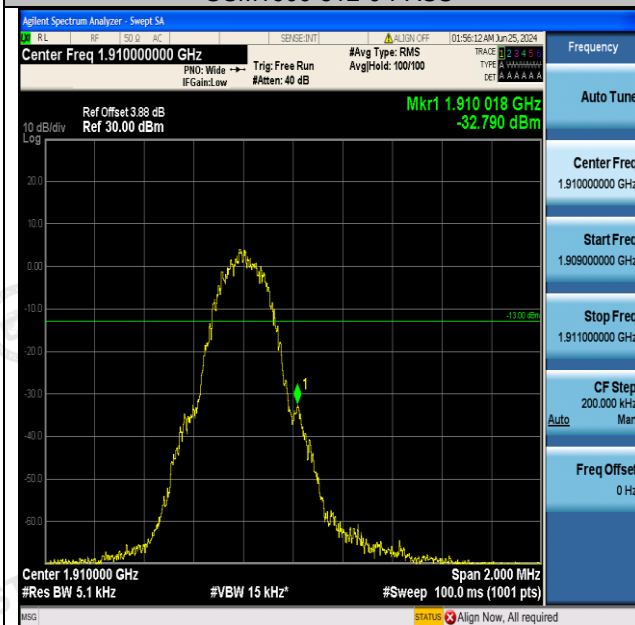

GSM1900-810-0-PASS

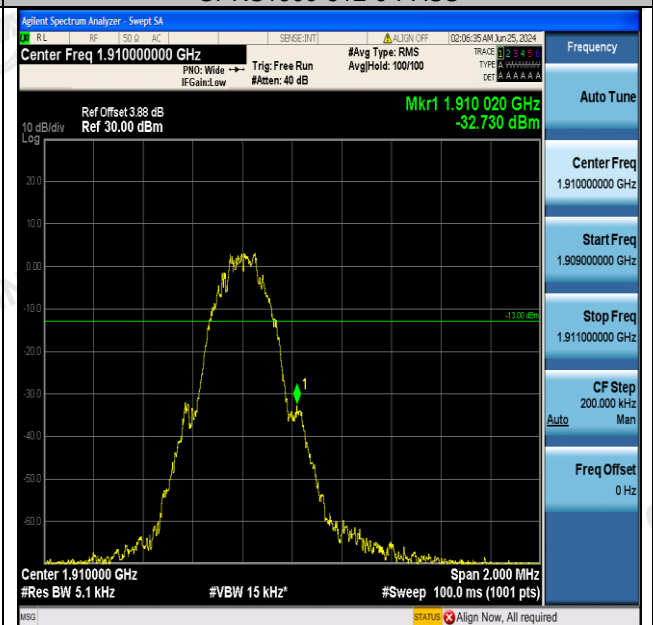

GPRS1900-810-0-PASS

## 4.5 Spurious Emission on Antenna Port

### TEST APPLICABLE

The following steps outline the procedure used to measure the conducted emissions from the EUT.

1. Determine frequency range for measurements: From CFR 2.1057 the spectrum should be investigated from the lowest radio frequency generated in the equipment up to at least the 10<sup>th</sup> harmonic of the carrier frequency. For the equipment of PCS1900 band, this equates to a frequency range of 9 KHz to 19.1 GHz, data taken from 9 KHz to 25 GHz. For GSM850, data taken from 9 KHz to 9 GHz.
2. The sweep time is set automatically by instrument itself. That should be the optimal sweep time for the span and the RBW. If the sweep time is too short, that is sweep is too fast, the sweep result is not accurate; if the sweep time is too long, that is sweep is too low, some frequency components may be lost. The instrument will give an optimal sweep time according the selected span and RBW.
3. The procedure to get the conducted spurious emission is as follows:  
The trace mode is set to MaxHold to get the highest signal at each frequency;  
Wait 25 seconds;  
Get the result.
4. Determine EUT transmit frequencies: below outlines the band edge frequencies pertinent to conducted emissions testing.

### TEST CONFIGURATION

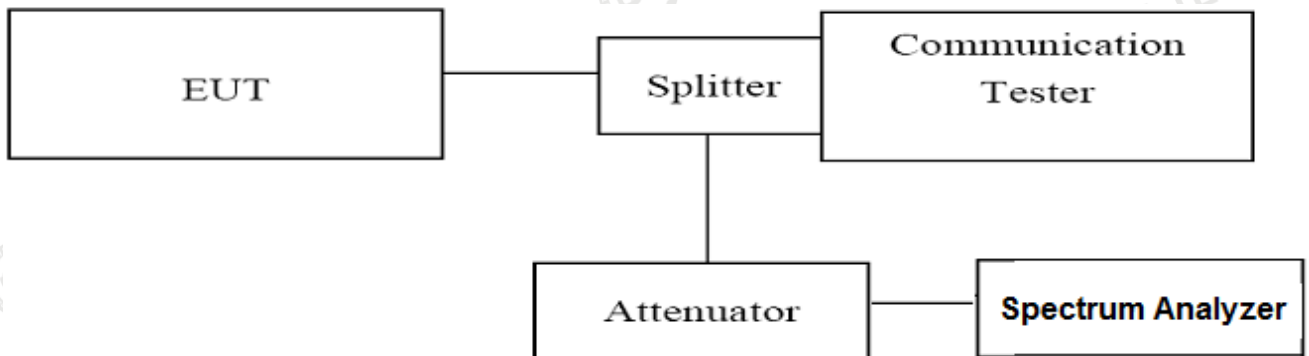

### TEST PROCEDURE

1. The EUT was set up for the max output power with pseudo random data modulation;
2. The power was measured with Agilent Spectrum Analyzer N9030A (peak);
3. These measurements were done at 3 frequencies, 1850.20 MHz, 1880.00 MHz and 1909.80 MHz for PCS1900 band; 824.20 MHz, 836.60 MHz and 848.80 MHz for GSM850 band. (Low, middle and high of operational frequency range).

### TEST LIMIT

Part 24.238 and Part 22.917 specify that the power of any emission outside of the authorized operating frequency ranges must be attenuated below the transmitting power (P) by a factor of at least  $43 + 10 \log(P)$  dB.

The specification that emissions shall be attenuated below the transmitter power (P) by at least  $43 + 10 \log(P)$  dB, translates in the relevant power range (1 to 0.001 W) to -13 dBm. At 1 W the specified minimum attenuation becomes 43 dB and relative to a 30 dBm (1 W) carrier becomes a limit of -13 dBm. At 0.001 W (0 dBm) the minimum attenuation is 13 dB, which again yields a limit of -13 dBm. In this way a translation of the specification from relative to absolute terms is carried out.

### TEST RESULTS

**Note:**We tested GSM and GPRS mode and recorded the worst case at the GSM mode.

#### 4.5.1 For GSM 850 Test Results

##### A. Test Verdict

Band	Channel	Frequency Range(MHz)	Max.Freq. (MHz)	Result (dBm)	Limit (dBm)	Verdict
GSM850	128	0.009~0.15MHz	0.01	-52.55	-33	PASS
GPRS850	128	0.009~0.15MHz	0.01	-53.32	-33	PASS
GSM850	128	0.15~30MHz	0.15	-49.67	-23	PASS
GPRS850	128	0.15~30MHz	0.15	-49.62	-23	PASS
GSM850	128	30~1000MHz	203.69	-50.21	-13	PASS
GPRS850	128	30~1000MHz	205.31	-50.04	-13	PASS
GSM850	128	1000~10000MHz	2472.7	-39.77	-13	PASS
GPRS850	128	1000~10000MHz	3290.8	-53	-13	PASS
GSM850	190	0.009~0.15MHz	0.01	-53.63	-33	PASS
GPRS850	190	0.009~0.15MHz	0.01	-52.21	-33	PASS
GSM850	190	0.15~30MHz	0.16	-48.92	-23	PASS
GPRS850	190	0.15~30MHz	0.15	-48.18	-23	PASS
GSM850	190	30~1000MHz	960.07	-50.07	-13	PASS
GPRS850	190	30~1000MHz	994.31	-50	-13	PASS
GSM850	190	1000~10000MHz	2509.9	-37.75	-13	PASS
GPRS850	190	1000~10000MHz	2509.9	-39.92	-13	PASS
GSM850	251	0.009~0.15MHz	0.01	-52.48	-33	PASS
GPRS850	251	0.009~0.15MHz	0.01	-51.36	-33	PASS
GSM850	251	0.15~30MHz	0.16	-48.61	-23	PASS
GPRS850	251	0.15~30MHz	0.16	-49.31	-23	PASS
GSM850	251	30~1000MHz	220.83	-49.51	-13	PASS
GPRS850	251	30~1000MHz	197.71	-50.17	-13	PASS
GSM850	251	1000~10000MHz	2546.5	-39.83	-13	PASS
GPRS850	251	1000~10000MHz	2546.5	-36.59	-13	PASS

##### Note:

1. In general, the worse case attenuation requirement shown above was applied.
2. "----" means that the emission level is too low to be measured or at least 20 dB down than the limit.

##### B. Test Plots



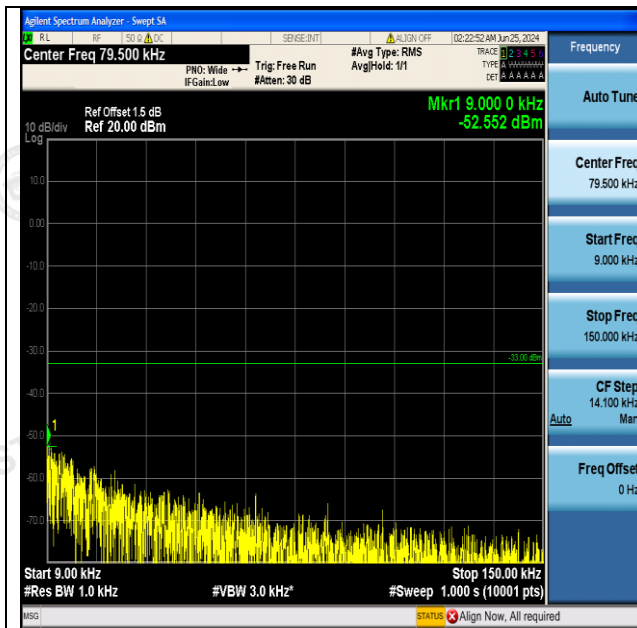

GSM850-128-5-0.009~0.15MHz-PASS

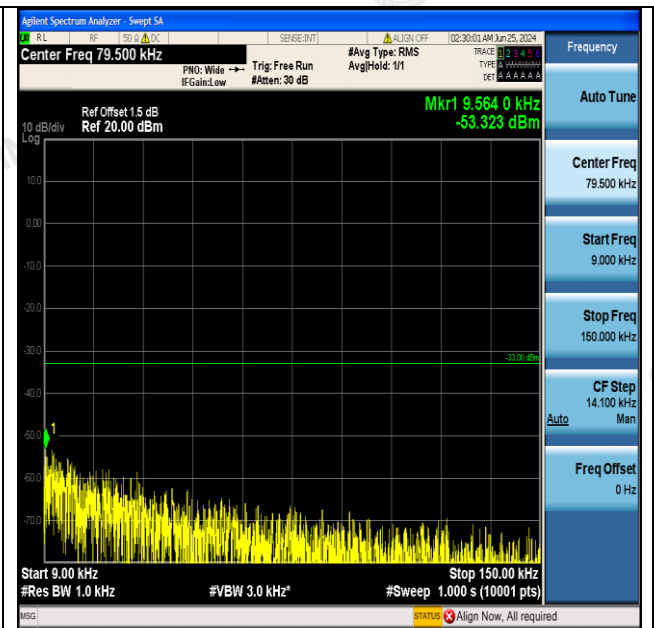

GPRS850-128-5-0.009~0.15MHz-PASS

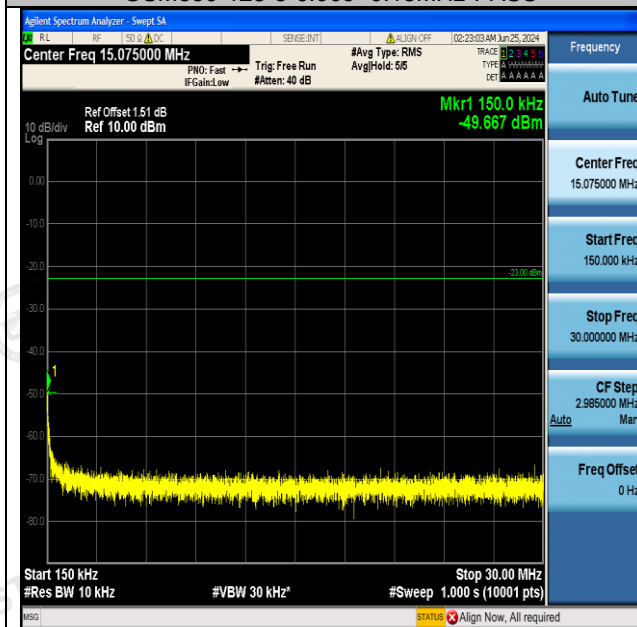

GSM850-128-5-0.15~30MHz-PASS

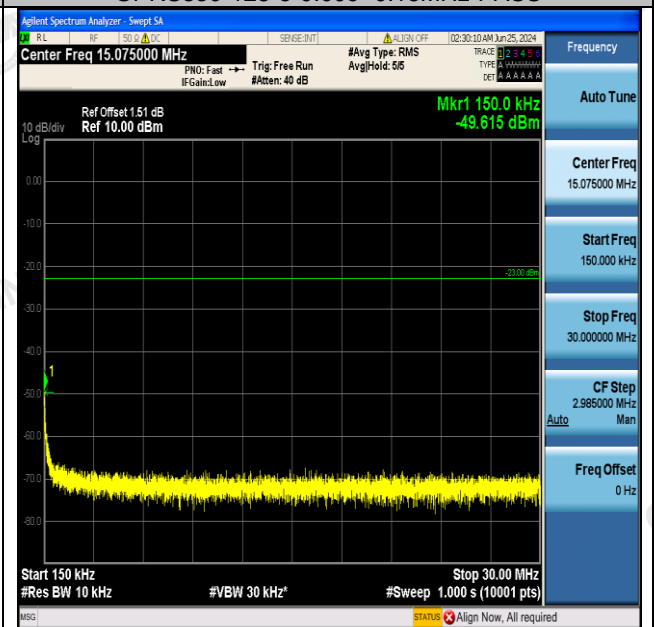

GPRS850-128-5-0.15~30MHz-PASS

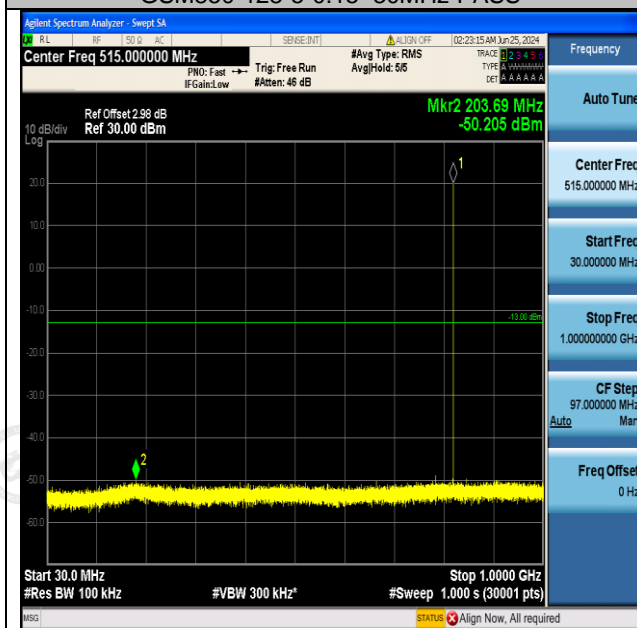

GSM850-128-5-30~1000MHz-PASS

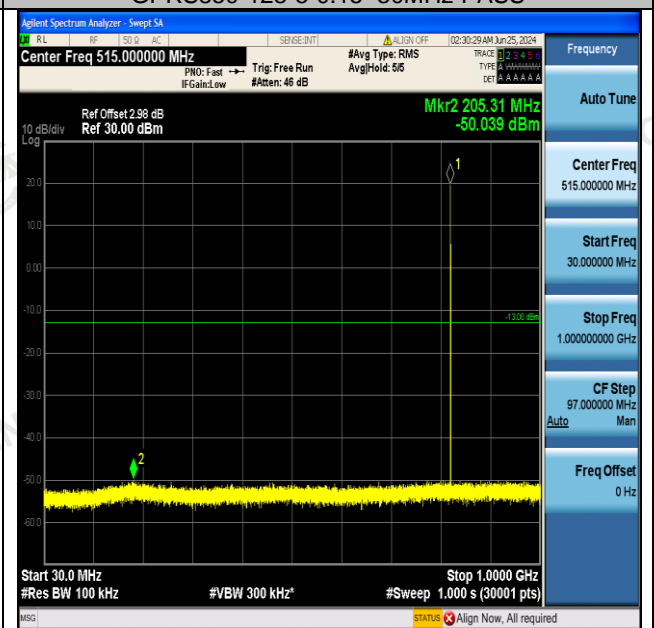

GPRS850-128-5-30~1000MHz-PASS

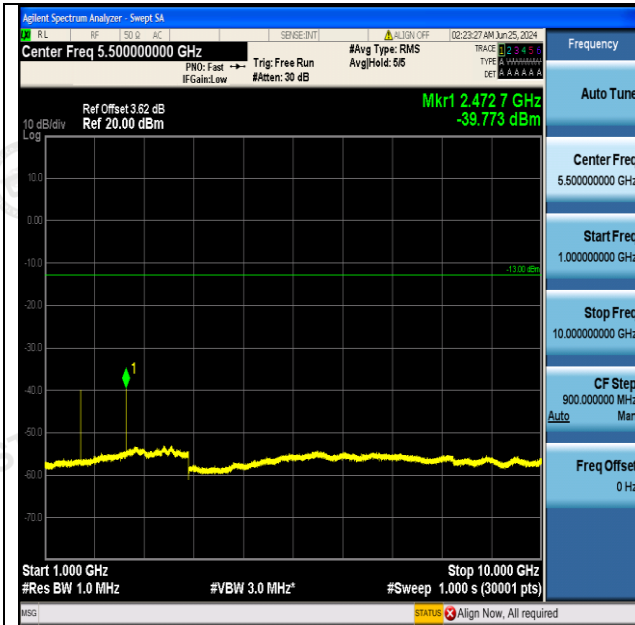

GSM850-128-5-1000~10000MHz-PASS

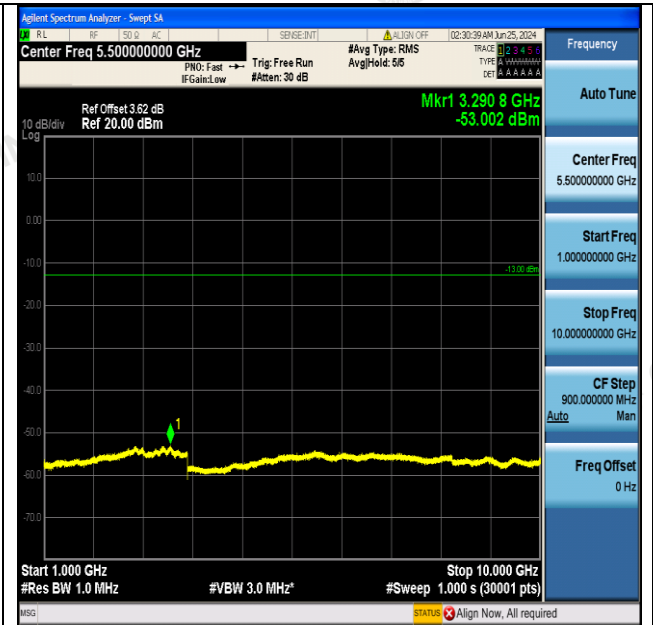

GPRS850-128-5-1000~10000MHz-PASS

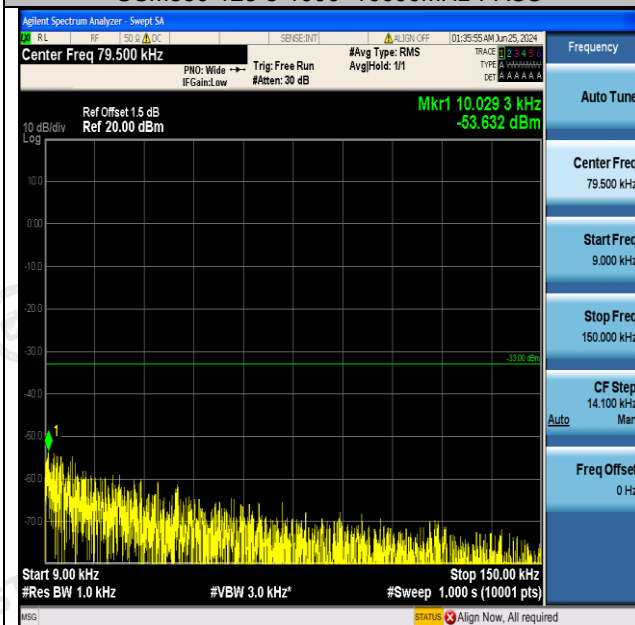

GSM850-190-5-0.009~0.15MHz-PASS

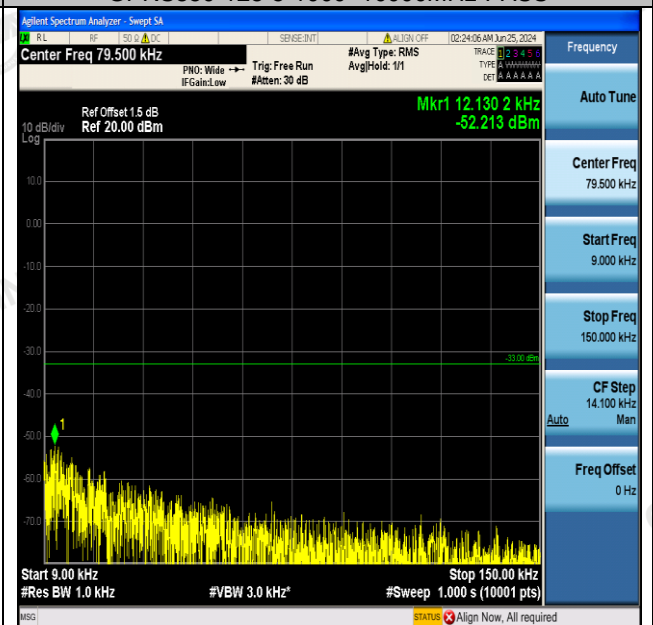

GPRS850-190-5-0.009~0.15MHz-PASS

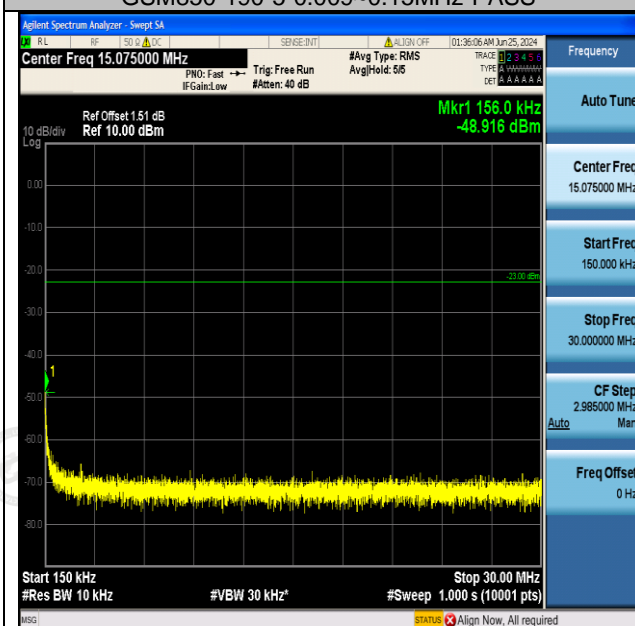

GSM850-190-5-0.15~30MHz-PASS

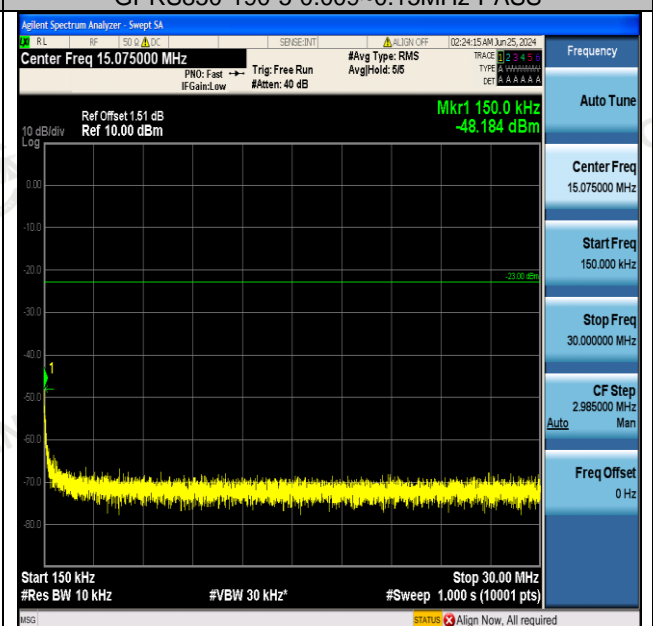

GPRS850-190-5-0.15~30MHz-PASS

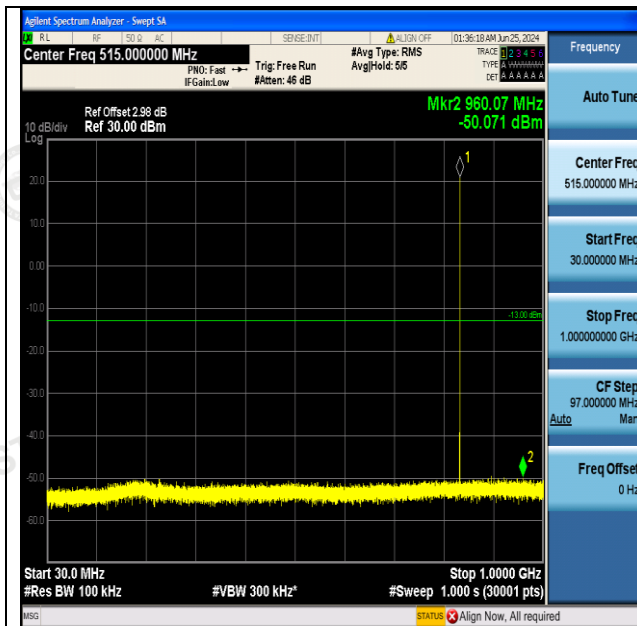

GSM850-190-5-30~1000MHz-PASS

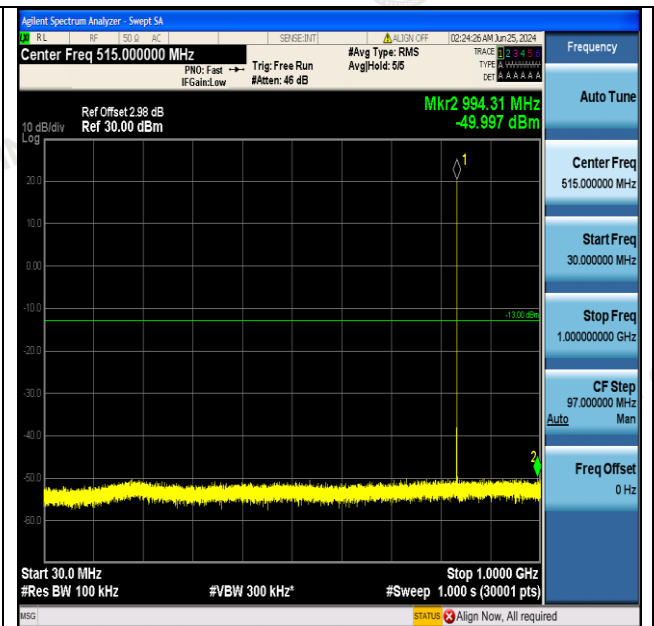

GPRS850-190-5-30~1000MHz-PASS

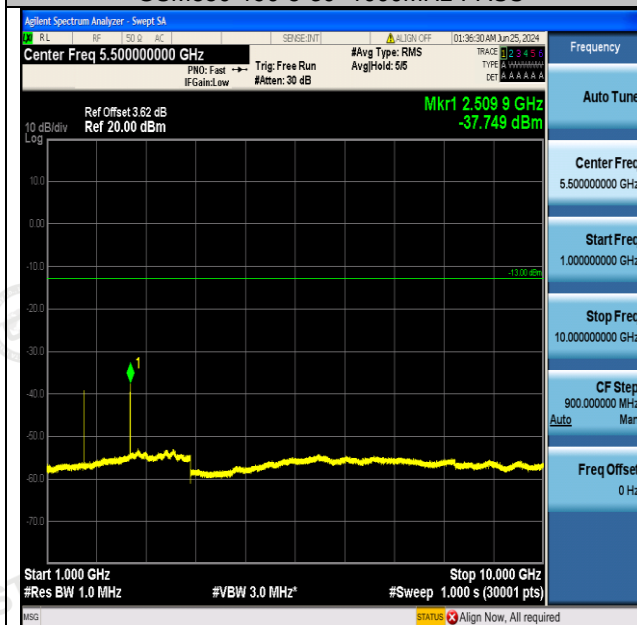

GSM850-190-5-1000~10000MHz-PASS

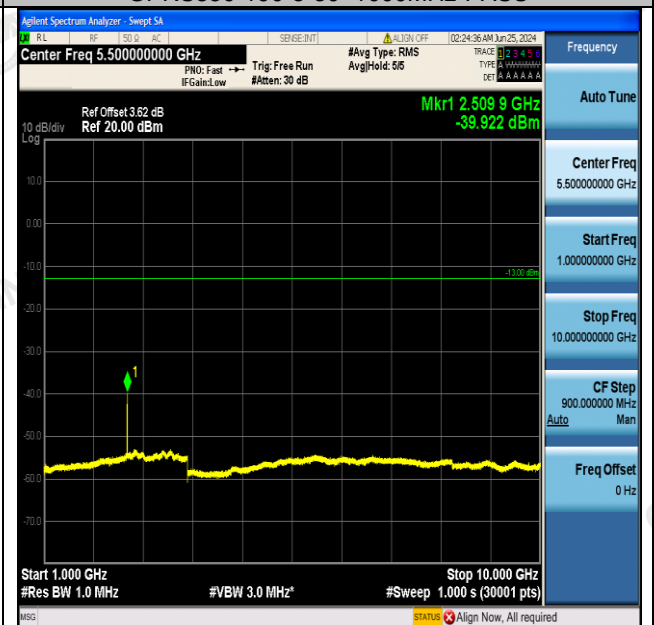

GPRS850-190-5-1000~10000MHz-PASS

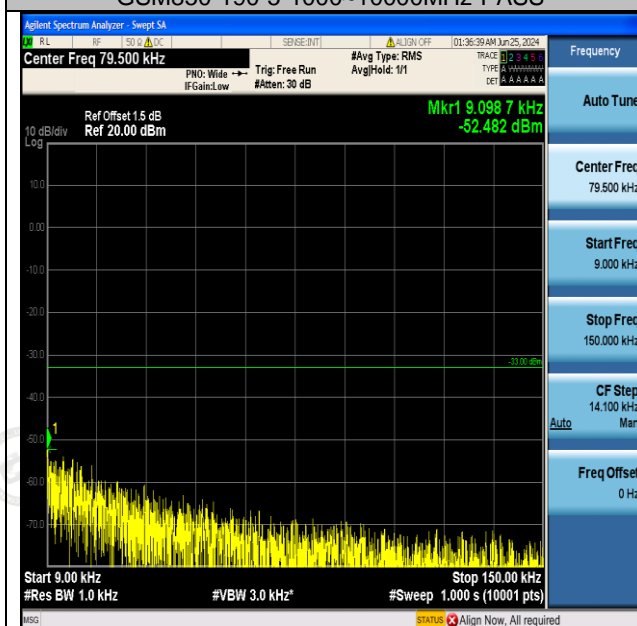

GSM850-251-5-0.009~0.15MHz-PASS

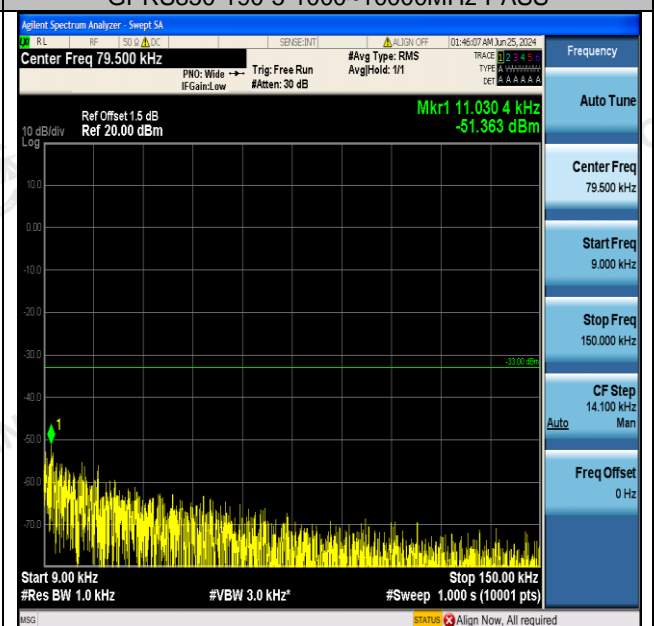

GPRS850-251-5-0.009~0.15MHz-PASS

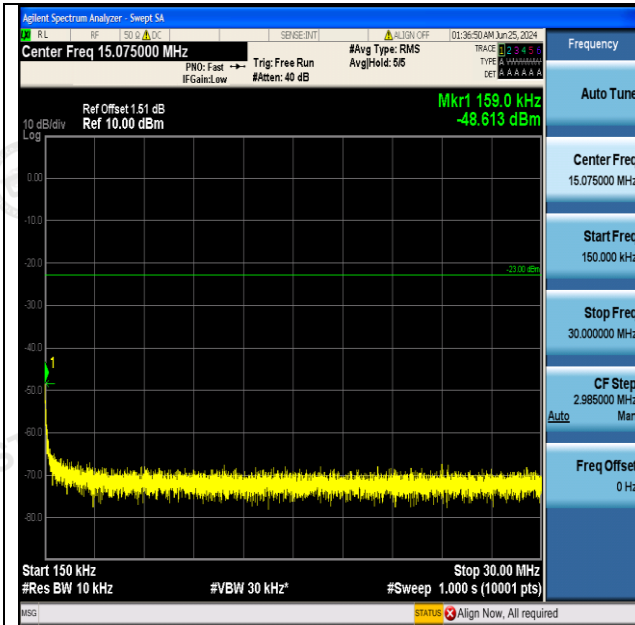

GSM850-251-5-0.15~30MHz-PASS

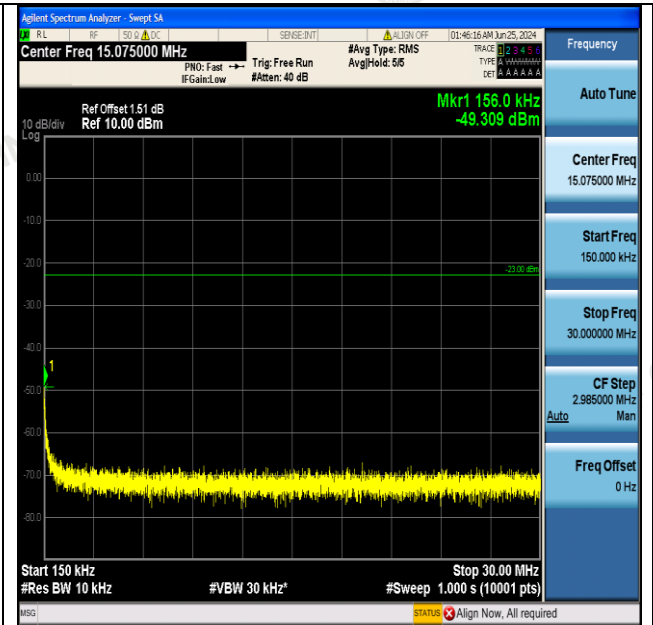

GPRS850-251-5-0.15~30MHz-PASS

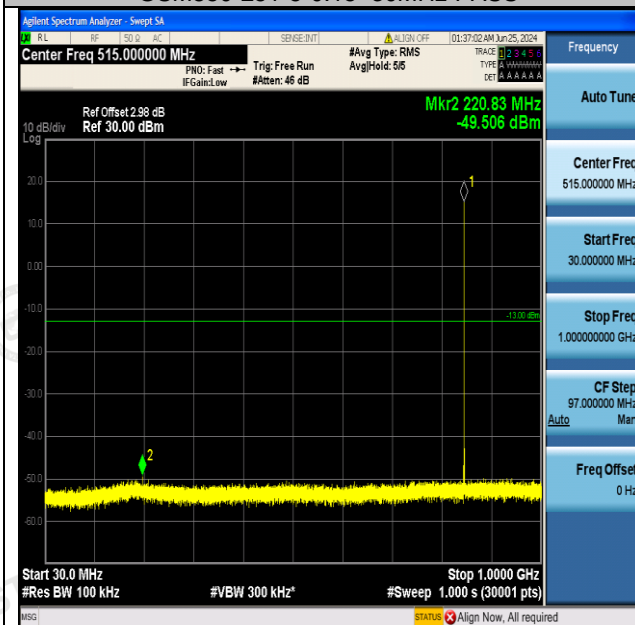

GSM850-251-5-30~1000MHz-PASS

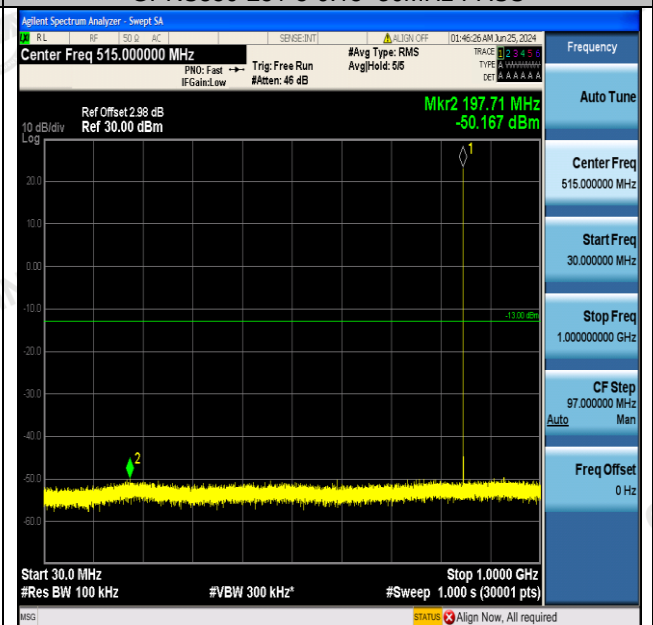

GPRS850-251-5-30~1000MHz-PASS

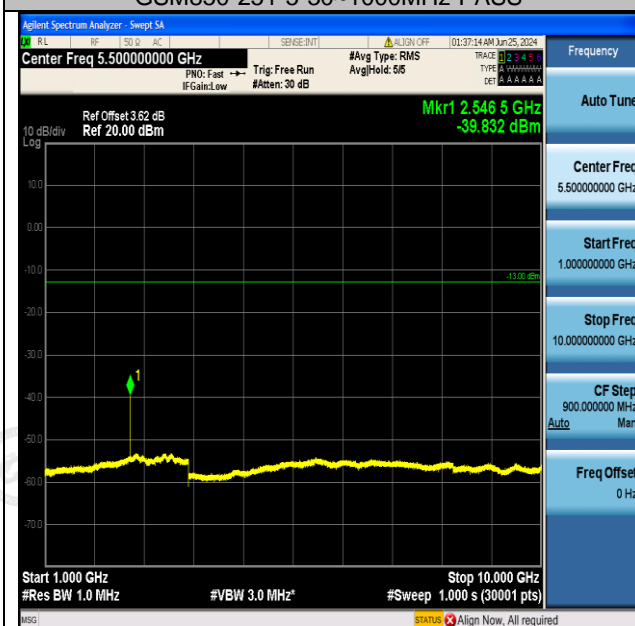

GSM850-251-5-1000~10000MHz-PASS

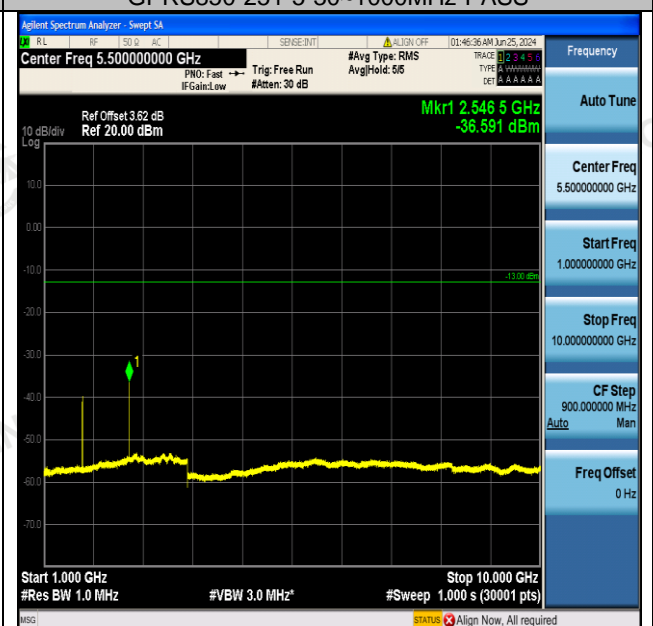

GPRS850-251-5-1000~10000MHz-PASS

## 4.5.2 For GSM 1900 Test Results

### A. Test Verdict

Band	Channel	Frequency Range(MHz)	Max.Freq. (MHz)	Result (dBm)	Limit (dBm)	Verdict
GSM1900	512	0.009~0.15MHz	0.01	-54.38	-43	PASS
GPRS1900	512	0.009~0.15MHz	0.01	-53.94	-43	PASS
GSM1900	512	0.15~30MHz	0.15	-47.33	-33	PASS
GPRS1900	512	0.15~30MHz	0.17	-48.31	-33	PASS
GSM1900	512	30~1000MHz	891.55	-47.88	-13	PASS
GPRS1900	512	30~1000MHz	920.52	-47.71	-13	PASS
GSM1900	512	1000~3000MHz	2635.47	-38.55	-13	PASS
GPRS1900	512	1000~3000MHz	2664.27	-38.37	-13	PASS
GSM1900	512	3000~18000MHz	16921	-47.87	-13	PASS
GPRS1900	512	3000~18000MHz	16904	-47.78	-13	PASS
GSM1900	661	0.009~0.15MHz	0.01	-52.74	-43	PASS
GPRS1900	661	0.009~0.15MHz	0.01	-54.6	-43	PASS
GSM1900	661	0.15~30MHz	0.17	-48.62	-33	PASS
GPRS1900	661	0.15~30MHz	0.16	-49.46	-33	PASS
GSM1900	661	30~1000MHz	927.44	-47.77	-13	PASS
GPRS1900	661	30~1000MHz	907.01	-47.81	-13	PASS
GSM1900	661	1000~3000MHz	2666.53	-38.55	-13	PASS
GPRS1900	661	1000~3000MHz	2645.4	-38.61	-13	PASS
GSM1900	661	3000~18000MHz	16914.5	-47.93	-13	PASS
GPRS1900	661	3000~18000MHz	16913.5	-47.88	-13	PASS
GSM1900	810	0.009~0.15MHz	0.01	-54.78	-43	PASS
GPRS1900	810	0.009~0.15MHz	0.01	-54.8	-43	PASS
GSM1900	810	0.15~30MHz	0.15	-50.53	-33	PASS
GPRS1900	810	0.15~30MHz	0.15	-48.14	-33	PASS
GSM1900	810	30~1000MHz	938.86	-47.94	-13	PASS
GPRS1900	810	30~1000MHz	900.03	-47.75	-13	PASS
GSM1900	810	1000~3000MHz	2656.27	-38.49	-13	PASS
GPRS1900	810	1000~3000MHz	2670.13	-38.5	-13	PASS
GSM1900	810	3000~18000MHz	16985.5	-47.98	-13	PASS
GPRS1900	810	3000~18000MHz	16928	-47.95	-13	PASS

### Note:

1. In general, the worse case attenuation requirement shown above was applied.
2. "----" means that the emission level is too low to be measured or at least 20 dB down than the limit.

### B. Test Plots



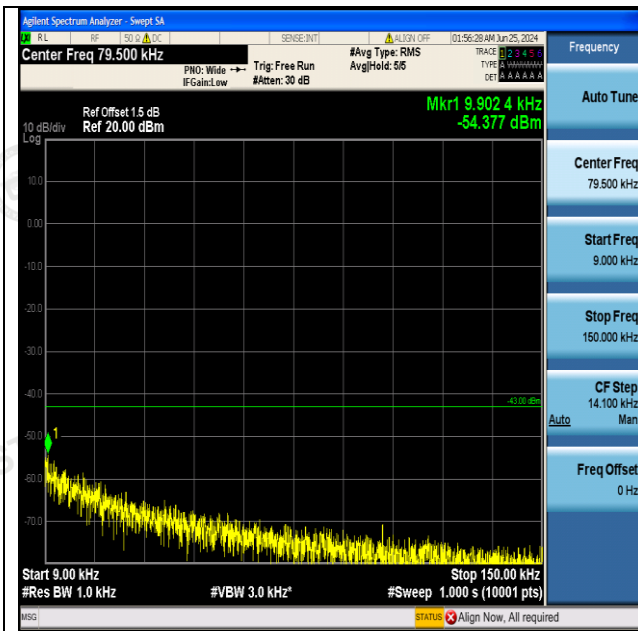

GSM1900-512-0-0.009~0.15MHz-PASS

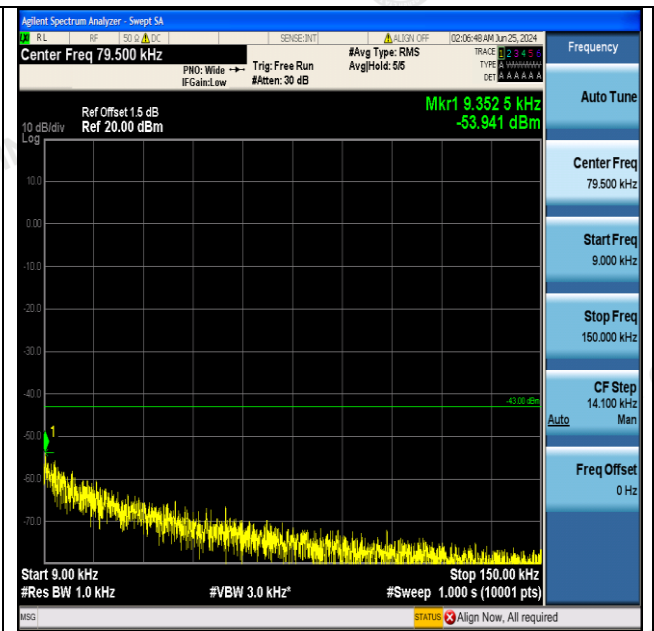

GPRS1900-512-0-0.009~0.15MHz-PASS

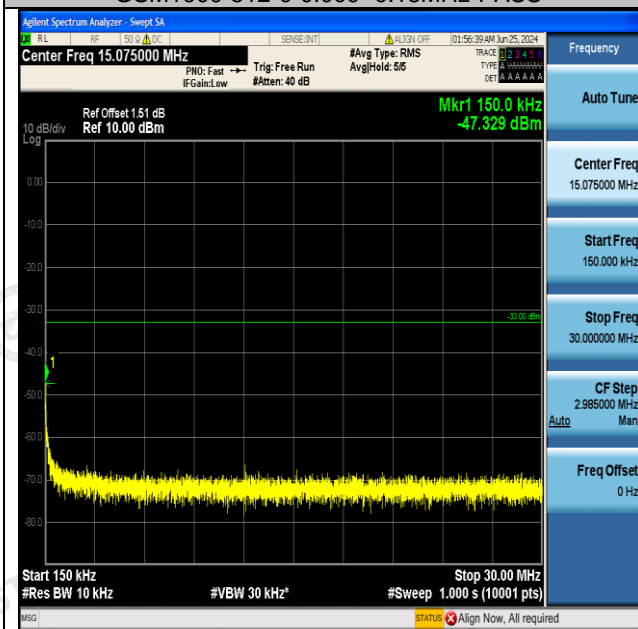

GSM1900-512-0-0.15~30MHz-PASS

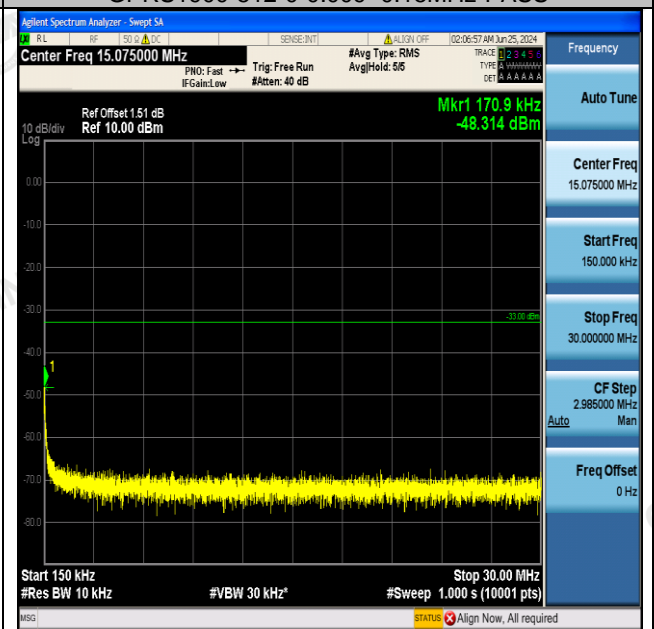

GPRS1900-512-0-0.15~30MHz-PASS

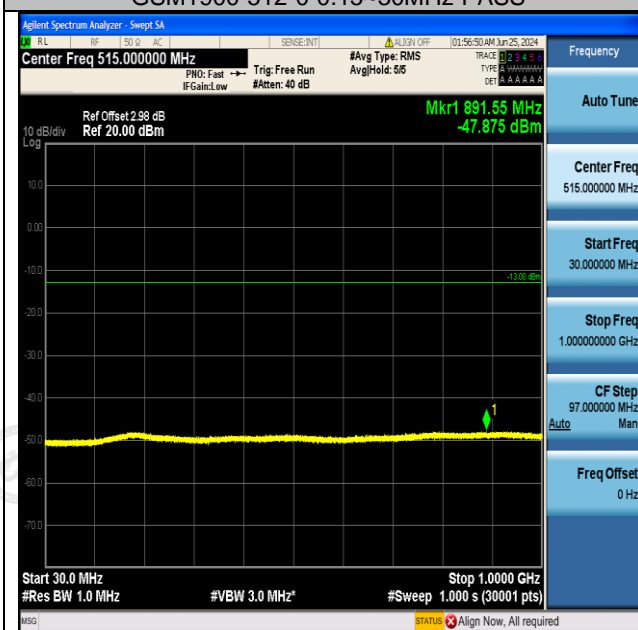

GSM1900-512-0-30~100MHz-PASS



GPRS1900-512-0-30~100MHz-PASS

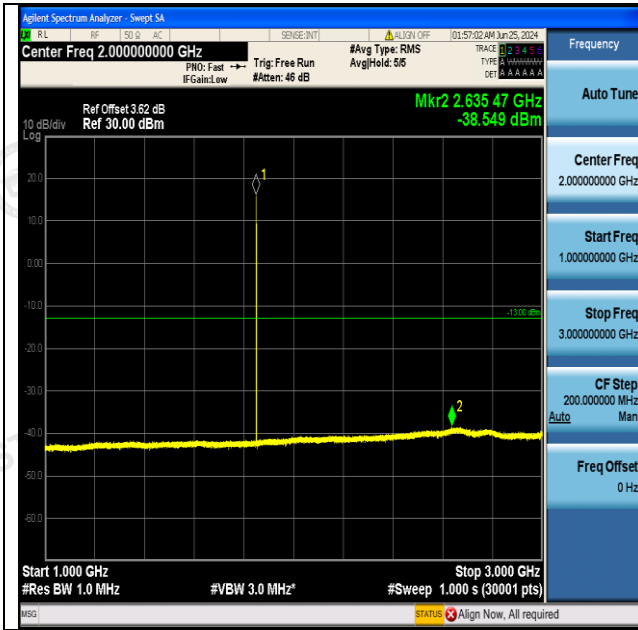

GSM1900-512-0-1000~3000MHz-PASS

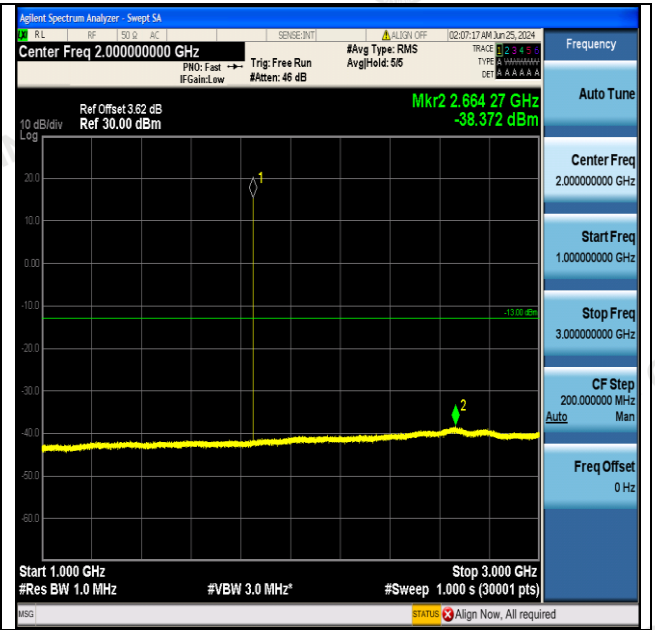

GPRS1900-512-0-1000~3000MHz-PASS

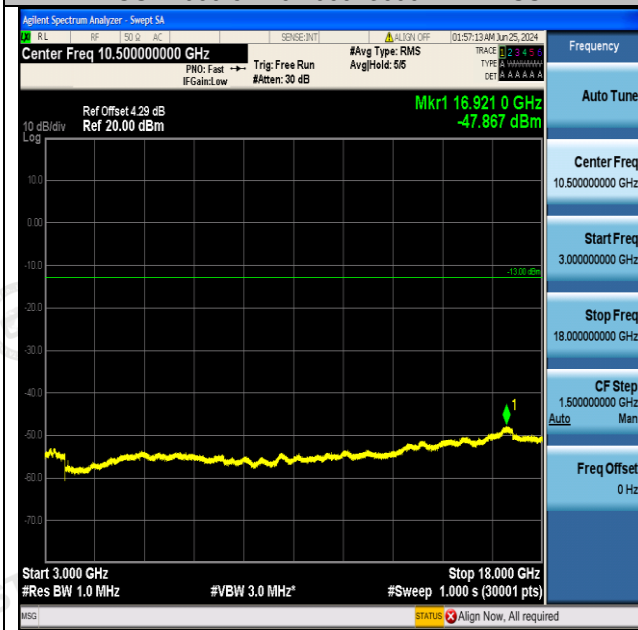

GSM1900-512-0-3000~18000MHz-PASS

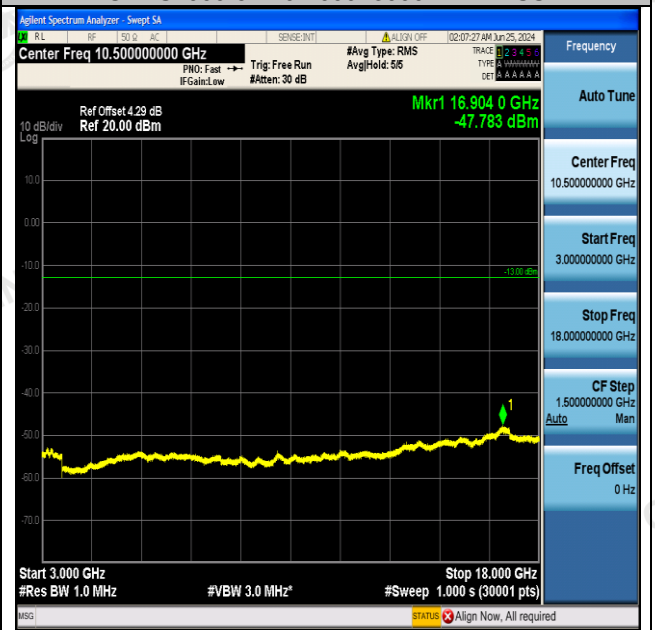

GPRS1900-512-0-3000~18000MHz-PASS

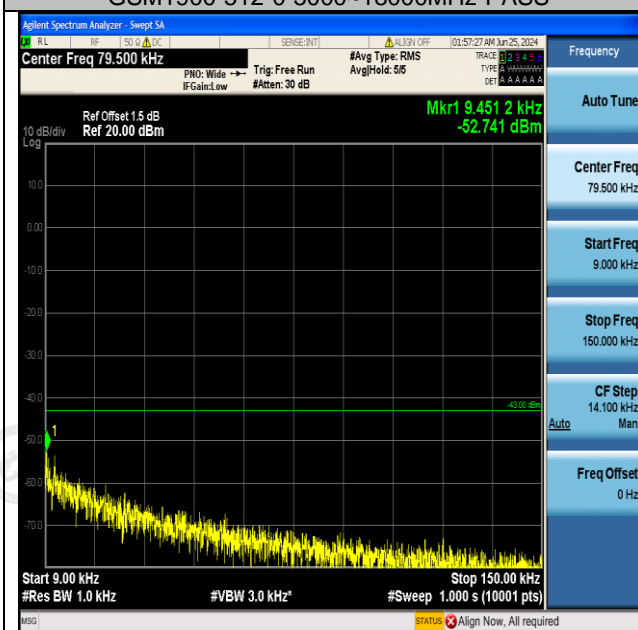

GSM1900-661-0-0.009~0.15MHz-PASS

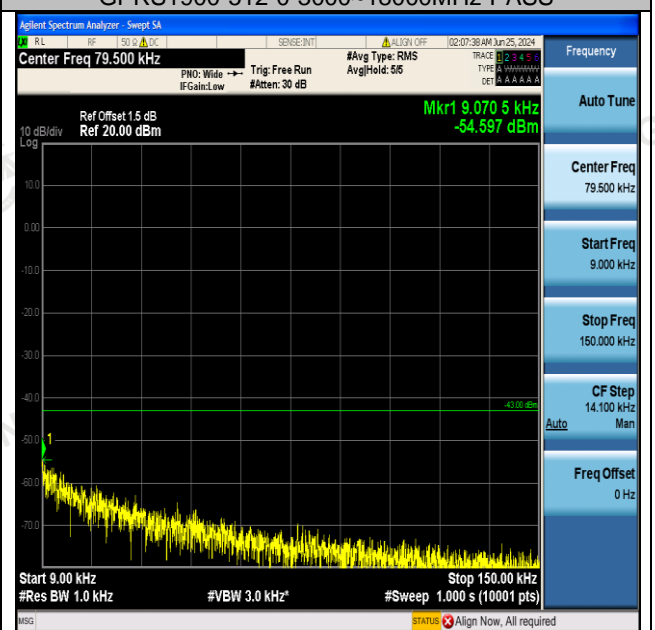

GPRS1900-661-0-0.009~0.15MHz-PASS