

# TEST REPORT

**Reference No.**..... : WTD24D01019176W004  
**FCC ID** ..... : 2AQRM-MF3  
**Applicant**..... : FOXX Development Inc.  
**Address**..... : 3480 Preston Ridge Road, Suite500, Alpharetta, GA 30005, USA  
**Manufacturer** ..... : FOXX Development Inc.  
**Address**..... : 3480 Preston Ridge Road, Suite500, Alpharetta, GA 30005, USA  
**Product**..... : LTE MiFi Router  
**Model(s)** ..... : MF3  
**Standards**..... : FCC CFR47 Part 22 Subpart H  
FCC CFR47 Part 24 Subpart E  
FCC CFR47 Part 27  
**Date of Receipt sample** .... : 2024-01-26  
**Date of Test** ..... : 2024-02-19 to 2024-04-01  
**Date of Issue**..... : 2024-04-01  
**Test Result**..... : **Pass**

Remarks:

The results shown in this test report refer only to the sample(s) tested, this test report cannot be reproduced, except in full, without prior written permission of the company. The report would be invalid without specific stamp of test institute and the signatures of compiler and approver.

**Prepared By:**

**Waltek Testing Group Co., Ltd.**

Address: No. 77, Houjie Section, Guantai Road, Houjie Town, Dongguan City, Guangdong, China

Tel: +86-769-2267 6998

Fax: +86-769-2267 6828

Compiled by:

*James Cheng*  
James Cheng / Project Engineer

Approved by:

*Deval Qin*  
Deval Qin / Designated Reviewer



## 2 Contents

	Page
<b>1 COVER PAGE.....</b>	<b>1</b>
<b>2 CONTENTS.....</b>	<b>2</b>
<b>3 REVISION HISTORY.....</b>	<b>4</b>
<b>4 GENERAL INFORMATION.....</b>	<b>5</b>
4.1 GENERAL DESCRIPTION OF E.U.T.....	5
4.2 DETAILS OF E.U.T.....	5
4.3 TEST MODE .....	7
4.4 TEST FACILITY .....	9
<b>5 TEST SUMMARY.....</b>	<b>10</b>
<b>6 EQUIPMENT USED DURING TEST.....</b>	<b>11</b>
6.1 EQUIPMENTS LIST .....	11
6.2 MEASUREMENT UNCERTAINTY .....	11
<b>7 RF OUTPUT POWER.....</b>	<b>12</b>
7.1 EUT OPERATION.....	12
7.2 TEST PROCEDURE.....	12
7.3 TEST RESULT.....	13
<b>8 PEAK-TO-AVERAGE RATIO.....</b>	<b>55</b>
8.1 EUT OPERATION.....	55
8.2 TEST PROCEDURE.....	55
8.3 TEST RESULT.....	55
<b>9 BANDWIDTH.....</b>	<b>56</b>
9.1 EUT OPERATION.....	56
9.2 TEST PROCEDURE.....	56
9.3 TEST RESULT.....	57
<b>10 SPURIOUS EMISSIONS AT ANTENNA TERMINALS.....</b>	<b>91</b>
10.1 EUT OPERATION .....	91
10.2 TEST PROCEDURE .....	91
10.3 TEST RESULT .....	91
<b>11 SPURIOUS RADIATED EMISSIONS.....</b>	<b>92</b>
11.1 EUT OPERATION .....	92
11.2 TEST SETUP .....	92
11.3 SPECTRUM ANALYZER SETUP.....	93
11.4 TEST PROCEDURE .....	94
11.5 SUMMARY OF TEST RESULTS .....	95
<b>12 BAND EDGE MEASUREMENT.....</b>	<b>101</b>
12.1 EUT OPERATION .....	101
12.2 TEST PROCEDURE .....	101
12.3 TEST RESULT .....	102
<b>13 FREQUENCY STABILITY.....</b>	<b>103</b>
13.1 EUT OPERATION .....	103
13.2 TEST PROCEDURE .....	103

13.3	TEST RESULT .....	104
<b>14</b>	<b>RF EXPOSURE .....</b>	<b>132</b>
<b>15</b>	<b>PHOTOGRAPHS OF TEST SETUP AND EUT.....</b>	<b>132</b>

### 3 Revision History

Test Report No.	Date of Receipt Sample	Date of Test	Date of Issue	Purpose	Comment	Approved
WTD24D01019176W004	2024-01-26	2024-02-19 to 2024-04-01	2024-04-01	Original	-	Valid

## 4 General Information

### 4.1 General Description of E.U.T.

Product:	LTE MiFi Router
Model(s):	MF3
Model Description:	N/A
LTE Band(s):	FDD Band 2/4/5/12/13/66
Hardware Version:	Mobile.M47.H01
Software Version:	Mobile.M47.B01
Highest frequency (Exclude Radio):	26MHz
Storage Location:	SD card Storage

### 4.2 Details of E.U.T.

Operation Frequency:	LTE Band 2: 1850~1910MHz LTE Band 4: 1710~1755MHz LTE Band 5: 824~849MHz LTE Band 12: 699~716MHz LTE Band 13: 777~787MHz LTE Band 66: 1710~1780MHz
Max. RF output power:	LTE Band 2: 22.77dBm LTE Band 4: 22.71dBm LTE Band 5: 23.48dBm LTE Band 12: 23.15dBm LTE Band 13: 22.98dBm LTE Band 66: 22.78dBm
Type of Modulation:	LTE: QPSK, 16QAM,64QAM
Antenna installation:	LTE: PCB printed antenna
Antenna Gain:	LTE Band 2: 3.1dBi LTE Band 4: 3.2dBi LTE Band 5: 2.6dBi LTE Band 12: -1dBi LTE Band 13: -0.8dBi LTE Band 66: 3.2dBi

Note:

#: The antenna gain is provided by the applicant, and the applicant should be responsible for its authenticity, WALTEK lab has not verified the authenticity of its information.

Ratings: Battery: DC 3.7V, 3000mAh, 11.1Wh

Adapter: Input: 100-240V~, 50/60Hz, 0.2A  
Output: 5.0V==1.0A

Type of Emission: LTE Band 2 1.4MHz: 1M09G7D(QPSK), 1M09W7D(16QAM)  
LTE Band 2 3MHz: 2M68G7D(QPSK), 2M68W7D(16QAM)  
LTE Band 2 5MHz: 4M49G7D(QPSK), 4M49W7D(16QAM)  
LTE Band 2 10 MHz: 8M92G7D(QPSK), 8M92W7D(16QAM)  
LTE Band 2 15MHz: 13M5G7D(QPSK), 13M5W7D(16QAM)  
LTE Band 2 20MHz: 17M9G7D(QPSK), 17M9W7D(16QAM)  
LTE Band 4 1.4MHz: 1M09G7D(QPSK), 1M09W7D(16QAM)  
LTE Band 4 3MHz: 2M68G7D(QPSK), 2M68W7D(16QAM)  
LTE Band 4 5MHz: 4M49G7D(QPSK), 4M49W7D(16QAM)  
LTE Band 4 10 MHz: 8M92G7D(QPSK), 8M91W7D(16QAM)  
LTE Band 4 15MHz: 13M5G7D(QPSK), 13M4W7D(16QAM)  
LTE Band 4 20MHz: 17M9G7D(QPSK), 17M9W7D(16QAM)  
LTE Band 5 1.4MHz: 1M09G7D(QPSK), 1M09W7D(16QAM)  
LTE Band 5 3MHz: 2M68G7D(QPSK), 2M68W7D(16QAM)  
LTE Band 5 5MHz: 4M49G7D(QPSK), 4M49W7D(16QAM)  
LTE Band 5 10 MHz: 8M92G7D(QPSK), 8M91W7D(16QAM)  
LTE Band 12 1.4MHz: 1M09G7D(QPSK), 1M09W7D(16QAM)  
LTE Band 12 3MHz: 2M68G7D(QPSK), 2M68W7D(16QAM)  
LTE Band 12 5MHz: 4M49G7D(QPSK), 4M49W7D(16QAM)  
LTE Band 12 10MHz: 8M92G7D(QPSK), 8M91W7D(16QAM)  
LTE Band 13 5MHz: 4M49G7D(QPSK), 4M49W7D(16QAM)  
LTE Band 13 10 MHz: 8M91G7D(QPSK), 8M90W7D(16QAM)  
LTE Band 66 1.4MHz: 1M09G7D(QPSK), 1M09W7D(16QAM)  
LTE Band 66 3MHz: 2M68G7D(QPSK), 2M68W7D(16QAM)  
LTE Band 66 5MHz: 4M49G7D(QPSK), 4M49W7D(16QAM)  
LTE Band 66 10 MHz: 8M92G7D(QPSK), 8M91W7D(16QAM)  
LTE Band 66 15MHz: 13M5G7D(QPSK), 13M4W7D(16QAM)  
LTE Band 66 20MHz: 17M9G7D(QPSK), 17M9W7D(16QAM)

### 4.3 Test Mode

All test mode(s) and condition(s) mentioned were considered and evaluated respectively by performing full tests, the worst data were recorded and reported.

Support Band	Test Mode BW(MHz)	Channel Frequency	Channel Number
LTE Band 2	1.4	1850.7 MHz	18607
		1880.0 MHz	18900
		1909.3 MHz	19193
	3	1851.5 MHz	18615
		1880.0 MHz	18900
		1908.5 MHz	19185
	5	1852.5 MHz	18625
		1880.0 MHz	18900
		1907.5 MHz	19175
	10	1855.0 MHz	18650
		1880.0 MHz	18900
		1905.0 MHz	19150
	15	1857.5 MHz	18675
		1880.0 MHz	18900
		1902.5 MHz	19125
20	1860.0 MHz	18700	
	1880.0 MHz	18900	
	1900.0 MHz	19100	
LTE Band 4	1.4	1710.7 MHz	19957
		1732.5 MHz	20175
		1754.3 MHz	20393
	3	1711.5 MHz	19965
		1732.5 MHz	20175
		1753.5 MHz	20385
	5	1712.5 MHz	19975
		1732.5 MHz	20175
		1752.5 MHz	20375
	10	1715.0 MHz	20000
		1732.5 MHz	20175
		1750.0 MHz	20350
	15	1717.5 MHz	20025
		1732.5 MHz	20175
		1747.5 MHz	20325
20	1720.0 MHz	20050	
	1732.5 MHz	20175	
	1745.0 MHz	20300	
LTE Band 5	1.4	824.7 MHz	20407
		836.5 MHz	20525
		848.3 MHz	20643
	3	825.5 MHz	20415
		836.5 MHz	20525
		847.5 MHz	20635
	5	826.5 MHz	20425
		836.5 MHz	20525
		846.5 MHz	20625
10	829.0 MHz	20450	

		836.5 MHz	20525
		844.0 MHz	20600
LTE Band 12	1.4	699.7 MHz	23017
		707.5 MHz	23095
		715.3 MHz	23173
	3	700.5 MHz	23025
		707.5 MHz	23095
		714.5 MHz	23165
	5	701.5 MHz	23035
		707.5 MHz	23095
		713.5 MHz	23155
	10	704.0 MHz	23060
		707.5 MHz	23095
		711.0 MHz	23130
LTE Band 13	5	779.5 MHz	23205
		782.0 MHz	23230
		784.5 MHz	23255
	10	782.0 MHz	23230
LTE Band 66	1.4	1710.7MHz	131979
		1745.0 MHz	132322
		1779.3MHz	132665
	3	1711.5 MHz	131987
		1745.0 MHz	132322
		1778.5MHz	132657
	5	1712.5 MHz	131997
		1745.0 MHz	132325
		1777.5 MHz	132647
	10	1715.0 MHz	132022
		1745.0 MHz	132322
		1775.0 MHz	132622
	15	1717.5 MHz	132047
		1745.0 MHz	132322
		1772.5 MHz	132597
	20	1720.0 MHz	132072
		1745.0 MHz	132322
		1770.0 MHz	132572
Remark: All mode(s) were tested and the worst data was recorded.			



#### 4.4 Test Facility

The test facility has a test site registered with the following organizations:

**ISED CAB identifier: CN0013. Test Firm Registration No.: 7760A.**

Waltek Testing Group Co., Ltd. Has been registered and fully described in a report filed with the Industry Canada. The acceptance letter from the Industry Canada is maintained in our files. Registration number 7760A, October 15, 2016.

**FCC Designation No.: CN1201. Test Firm Registration No.: 523476.**

Waltek Testing Group Co., Ltd. EMC Laboratory has been registered and fully described in a report filed with the (FCC) Federal Communications Commission. The acceptance letter from the FCC is maintained in our files. Registration number 523476, September 10, 2019.

## 5 Test Summary

Test Items	Test Requirement	Result
RF Output Power	2.1046 22.913 (a) 24.232 (c) 27.50(h.2) 27.50(d.4)	PASS
Peak-to-Average Ratio	24.232 (d) 27.50(d)	PASS
Bandwidth	2.1049 22.905 22.917 24.238 27.53(a)	PASS
Spurious Emissions at Antenna Terminal	2.1051 22.917 (a) 24.238 (a) 27.53(h) 27.53(m)(4)	PASS
Field Strength of Spurious Radiation	2.1053 22.917 (a) 24.238 (a) 27.53(h) 27.53(m)(4)	PASS
Out of band emission	22.917 (a) 24.238 (a) 27.53(h) 27.53(m)(4)	PASS
Frequency Stability	2.1055 22.355 24.235 27.5(h) 27.54	PASS

## 6 Equipment Used during Test

### 6.1 Equipments List

Item	Equipment	Manufacturer	Model No.	Serial No.	Last Cal. Date	Calibration Due Date
<b>3m Semi-anechoic Chamber for Radiation Emissions 1#</b>						
1	Spectrum Analyzer	R&S	FSP30	100091	2023-04-24	2024-04-23
2	Amplifier	Agilent	8447D	2944A10178	2023-07-27	2024-07-26
3	Tri-log Broadband Antenna	SCHWARZBECK	VULB9163	336	2023-08-07	2024-08-06
4	Coaxial Cable	Top	TYPE16(13M)	-	2023-04-24	2024-04-23
5	Broad-band Horn Antenna	SCHWARZBECK	BBHA 9120D	667	2024-01-23	2025-01-22
6	Broad-band Horn Antenna	SCHWARZBECK	BBHA 9170	335	2023-07-27	2024-07-26
7	Broadband Pre-amplifier	COMPLIANCE	PAP-1G18	2004	2023-08-08	2024-08-07
8	Coaxial Cable	Top	ZT26-NJ-NJ-8M/FA	-	2023-04-24	2024-04-23
9	Microwave Amplifier	SCHWARZBECK	BBV 9721	100472	2023-07-27	2024-07-26
10	Coaxial Cable	Top	ZT40-2.92J-2.92J-2.0M	17100919	2023-04-24	2024-04-23
<b>3m Semi-anechoic Chamber for Radiation Emissions 2#</b>						
1	Test Receiver	R&S	ESCI	101296	2023-04-24	2024-04-23
2	Trilog Broadband Antenna	SCHWARZBECK	VULB9160	9160-3325	2023-11-04	2024-11-03
3	Active Loop Antenna	Com-Power	AL-130R	10160007	2023-05-07	2024-05-06
4	Amplifier	ANRITSU	MH648A	M43381	2023-04-24	2024-04-23
5	Cable	HUBER+SUHNER	CBL2	525178	2023-04-24	2024-04-23
<b>RF Conducted Testing</b>						
1	Spectrum Analyzer	Agilent	N9020A	MY49100060	2023-07-27	2024-07-26
2	Universal Radio Communication Tester	R&S	CMW 500	127818	2023-04-24	2024-04-23

#### Test Software:

Test Item	Software name	Software version
Conduction disturbance Radiated Emission(3m)	EZ-EMC	EZ-EMC(RA-03A1-1)

### 6.2 Measurement Uncertainty

Parameter	Uncertainty
Conducted Emission	± 3.64 dB(AC mains 150KHz~30MHz)
Radiated Spurious Emissions	± 5.08 dB (Bilog antenna 30M~1000MHz)
	± 5.47 dB (Horn antenna 1000M~25000MHz)
Radio Frequency	± 1 x 10 <sup>-7</sup> Hz
RF Power	± 0.42 dB
RF Power Density	± 0.7dB
Conducted Spurious Emissions	± 2.76 dB (9kHz~26500MHz)
Confidence interval: 95%. Confidence factor:k=2	

## 7 RF Output Power

Test Requirement:	FCC Part 2.1046, 22.913 (a), 24.232 (c), 27.50(h.2); 27.50(d.4); 90.635
Test Method:	ANSI C63.26:2015 ANSI/TIA-603-E:2016
Test Mode:	TX transmitting

### 7.1 EUT Operation

Operating Environment :

Temperature:	23.9 °C
Humidity:	54.6 % RH
Atmospheric Pressure:	101.3kPa

### 7.2 Test Procedure

Conducted method:

The RF output of the transmitter was connected to the wireless test set and the spectrum analyzer through sufficient attenuation.

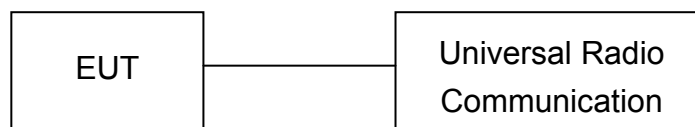

Radiated method:

1. The setup of EUT is according with per TIA/EIA Standard 603D:2010.
2. The measurement antenna was placed at a distance of 3 meters from the EUT. During the tests, the antenna height and polarization as well as EUT azimuth were varied in order to identify the maximum level of emissions from the EUT. The test was performed by placing the EUT on 3-orthogonal axis.
3. The frequency range up to tenth harmonic of the fundamental frequency was investigated.
4. Remove the EUT and replace it with substitution antenna. A signal generator was connected to the substitution antenna by a non-radiating cable. The absolute levels of the spurious emissions were measured by the substitution.

## 7.3 Test Result

## Conducted Power

## LTE Band 2:

BW(MHz)	Ch	Freq(MHz)	Mode	UL RB Allocation	UL RB Offset	Average Power (dbm)	Tune up limited(dBm)	MPR (dB)
1.4MHz	18607	1850.7	QPSK	1	0	22.65	22.0±1	/
				1	2	22.47	22.0±1	/
				1	5	22.58	22.0±1	/
				3	0	22.47	22.0±1	/
				3	1	22.47	22.0±1	/
				3	2	22.45	22.0±1	/
			6	0	21.46	22.0±1	1.0	
			16QAM	1	0	21.66	22.0±1	1.0
				1	2	21.57	22.0±1	1.0
				1	5	21.68	22.0±1	1.0
				3	0	21.55	22.0±1	1.0
				3	1	21.48	22.0±1	1.0
	3	2		21.46	22.0±1	1.0		
	6	0	20.65	22.0±1	1.0			
	18900	1880	QPSK	1	0	22.57	22.0±1	/
				1	2	22.43	22.0±1	/
				1	5	22.54	22.0±1	/
				3	0	22.37	22.0±1	/
				3	1	22.38	22.0±1	/
				3	2	22.37	22.0±1	/
			6	0	21.35	22.0±1	1.0	
			16QAM	1	0	21.84	21.0±1	1.0
				1	2	21.74	21.0±1	1.0
				1	5	21.86	21.0±1	1.0
3				0	21.53	21.0±1	1.0	
3				1	21.55	21.0±1	1.0	
3	2	21.54		21.0±1	1.0			
6	0	20.35	21.0±1	1.0				
19193	1909.3	QPSK	1	0	22.36	22.0±1	/	
			1	2	22.25	22.0±1	/	
			1	5	22.74	22.0±1	/	
			3	0	22.17	22.0±1	/	
			3	1	22.2	22.0±1	/	
			3	2	22.19	22.0±1	/	
		6	0	21.16	22.0±1	1.0		
		16QAM	1	0	21.24	22.0±1	1.0	
			1	2	21.22	22.0±1	1.0	
			1	5	21.8	22.0±1	1.0	
			3	0	21.33	22.0±1	1.0	
			3	1	21.36	22.0±1	1.0	
3	2		21.36	22.0±1	1.0			
6	0	20.31	22.0±1	1.0				

BW(MHz)	Ch	Freq(MHz)	Mode	UL RB Allocation	UL RB Offset	Average Power (dbm)	Tune up limited(dBm)	MPR (dB)
3MHz	18615	1851.5	QPSK	1	0	22.36	22.0±1	/
				1	8	22.38	22.0±1	/
				1	14	22.31	22.0±1	/
				6	0	21.36	22.0±1	1.0
				6	4	21.39	22.0±1	1.0
				6	9	21.37	22.0±1	1.0
			15	0	21.35	22.0±1	1.0	
			16QAM	1	0	21.23	21.0±1	1.0
				1	8	21.35	21.0±1	1.0
				1	14	21.34	21.0±1	1.0
				6	0	20.59	21.0±1	1.0
				6	4	20.63	21.0±1	1.0
	6	9		20.61	21.0±1	1.0		
	15	0	20.53	21.0±1	1.0			
	18900	1880	QPSK	1	0	22.3	22.0±1	/
				1	8	22.4	22.0±1	/
				1	14	22.36	22.0±1	/
				6	0	21.3	22.0±1	1.0
				6	4	21.35	22.0±1	1.0
				6	9	21.35	22.0±1	1.0
			15	0	21.31	22.0±1	1.0	
			16QAM	1	0	21.6	21.0±1	1.0
				1	8	21.73	21.0±1	1.0
				1	14	21.7	21.0±1	1.0
				6	0	20.46	21.0±1	1.0
				6	4	20.51	21.0±1	1.0
	6	9		20.51	21.0±1	1.0		
15	0	20.41	21.0±1	1.0				
19185	1908.5	QPSK	1	0	21.9	22.0±1	/	
			1	8	22.11	22.0±1	/	
			1	14	22.54	22.0±1	/	
			6	0	20.94	22.0±1	1.0	
			6	4	21.06	22.0±1	1.0	
			6	9	21.08	22.0±1	1.0	
		15	0	21	22.0±1	1.0		
		16QAM	1	0	20.86	20.7±1	1.0	
			1	8	21.11	20.7±1	1.0	
			1	14	21.59	20.7±1	1.0	
			6	0	19.95	20.7±1	1.0	
			6	4	20.07	20.7±1	1.0	
6	9		20.1	20.7±1	1.0			
15	0	19.95	20.7±1	1.0				

BW(MHz)	Ch	Freq(MHz)	Mode	UL RB Allocation	UL RB Offset	Average Power (dbm)	Tune up limited(dBm)	MPR (dB)
5MHz	18625	1852.5	QPSK	1	0	22.33	22.0±1	/
				1	12	22.38	22.0±1	/
				1	24	22.26	22.0±1	/
				12	0	21.26	22.0±1	1.0
				12	6	21.33	22.0±1	1.0
				12	11	21.27	22.0±1	1.0
				25	0	21.27	22.0±1	1.0
			16QAM	1	0	21.43	21.0±1	1.0
				1	12	21.52	21.0±1	1.0
				1	24	21.43	21.0±1	1.0
				12	0	20.43	21.0±1	1.0
				12	6	20.5	21.0±1	1.0
				12	11	20.44	21.0±1	1.0
				25	0	20.39	21.0±1	1.0
	18900	1880	QPSK	1	0	22.19	22.0±1	/
				1	12	22.37	22.0±1	/
				1	24	22.34	22.0±1	/
				12	0	21.21	22.0±1	1.0
				12	6	21.33	22.0±1	1.0
				12	11	21.32	22.0±1	1.0
				25	0	21.27	22.0±1	1.0
			16QAM	1	0	21.69	21.0±1	1.0
				1	12	21.87	21.0±1	1.0
				1	24	21.81	21.0±1	1.0
				12	0	20.43	21.0±1	1.0
				12	6	20.55	21.0±1	1.0
				12	11	20.54	21.0±1	1.0
				25	0	20.42	21.0±1	1.0
	19175	1907.5	QPSK	1	0	21.74	21.6±1	/
				1	12	22.06	21.6±1	/
1				24	22.54	21.6±1	/	
12				0	20.7	21.6±1	1.0	
12				6	20.93	21.6±1	1.0	
12				11	20.98	21.6±1	1.0	
25				0	20.87	21.6±1	1.0	
16QAM			1	0	20.81	20.7±1	1.0	
			1	12	21.11	20.7±1	1.0	
			1	24	21.7	20.7±1	1.0	
			12	0	19.73	20.7±1	1.0	
			12	6	19.97	20.7±1	1.0	
			12	11	20.02	20.7±1	1.0	
			25	0	19.81	20.7±1	1.0	

BW(MHz)	Ch	Freq(MHz)	Mode	UL RB Allocation	UL RB Offset	Average Power (dbm)	Tune up limited(dBm)	MPR (dB)
10MHz	18650	1855	QPSK	1	0	22.12	22.0±1	/
				1	24	22.24	22.0±1	/
				1	49	22.03	22.0±1	/
				25	0	21.12	22.0±1	1.0
				25	12	21.2	22.0±1	1.0
				25	24	21.14	22.0±1	1.0
				50	0	21.18	22.0±1	1.0
			16QAM	1	0	21.02	21.0±1	1.0
				1	24	21.17	21.0±1	1.0
				1	49	20.99	21.0±1	1.0
				25	0	20.23	21.0±1	1.0
				25	12	20.41	21.0±1	1.0
				25	24	20.26	21.0±1	1.0
				50	0	20.27	21.0±1	1.0
	18900	1880	QPSK	1	0	21.97	21.5±1	/
				1	24	22.23	21.5±1	/
				1	49	22.12	21.5±1	/
				25	0	20.92	21.5±1	1.0
				25	12	21.15	21.5±1	1.0
				25	24	21.09	21.5±1	1.0
				50	0	21.03	21.5±1	1.0
			16QAM	1	0	21.26	21.0±1	1.0
				1	24	21.58	21.0±1	1.0
				1	49	21.48	21.0±1	1.0
				25	0	20.03	21.0±1	1.0
				25	12	20.27	21.0±1	1.0
				25	24	20.2	21.0±1	1.0
				50	0	20.14	21.0±1	1.0
	19150	1905	QPSK	1	0	21.81	21.0±1	/
				1	24	21.61	21.0±1	/
1				49	21.88	21.0±1	/	
25				0	20.51	21.0±1	1.0	
25				12	20.56	21.0±1	1.0	
25				24	20.6	21.0±1	1.0	
50				0	20.54	21.0±1	1.0	
16QAM			1	0	20.8	20.0±1	1.0	
			1	24	20.63	20.0±1	1.0	
			1	49	20.92	20.0±1	1.0	
			25	0	19.59	20.0±1	1.0	
			25	12	19.65	20.0±1	1.0	
			25	24	19.67	20.0±1	1.0	
			50	0	19.58	20.0±1	1.0	



BW(MHz)	Ch	Freq(MHz)	Mode	UL RB Allocation	UL RB Offset	Average Power (dbm)	Tune up limited(dBm)	MPR (dB)
15MHz	18675	1857.5	QPSK	1	0	22.16	22.0±1	/
				1	37	22.3	22.0±1	/
				1	74	22.04	22.0±1	/
				36	0	21.27	22.0±1	1.0
				36	16	21.36	22.0±1	1.0
				36	35	21.24	22.0±1	1.0
				75	0	21.22	22.0±1	1.0
			16QAM	1	0	21.14	21.0±1	1.0
				1	37	21.32	21.0±1	1.0
				1	74	21.09	21.0±1	1.0
				36	0	20.36	21.0±1	1.0
				36	16	20.45	21.0±1	1.0
				36	35	20.34	21.0±1	1.0
				75	0	20.33	21.0±1	1.0
	18900	1880	QPSK	1	0	22.03	22.0±1	/
				1	37	22.26	22.0±1	/
				1	74	22.26	22.0±1	/
				36	0	21	22.0±1	1.0
				36	16	21.22	22.0±1	1.0
				36	35	21.27	22.0±1	1.0
				75	0	21.14	22.0±1	1.0
			16QAM	1	0	21.33	21.0±1	1.0
				1	37	21.61	21.0±1	1.0
				1	74	21.63	21.0±1	1.0
				36	0	20.13	21.0±1	1.0
				36	16	20.36	21.0±1	1.0
				36	35	20.41	21.0±1	1.0
75				0	20.25	21.0±1	1.0	
19125	1902.5	QPSK	1	0	22.06	21.5±1	/	
			1	37	21.71	21.5±1	/	
			1	74	21.97	21.5±1	/	
			36	0	20.95	21.5±1	1.0	
			36	16	20.74	21.5±1	1.0	
			36	35	20.61	21.5±1	1.0	
			75	0	20.83	21.5±1	1.0	
		16QAM	1	0	21.37	20.5±1	1.0	
			1	37	21.14	20.5±1	1.0	
			1	74	21.39	20.5±1	1.0	
			36	0	19.93	20.5±1	1.0	
			36	16	19.72	20.5±1	1.0	
			36	35	19.58	20.5±1	1.0	
			75	0	19.83	20.5±1	1.0	

BW(MHz)	Ch	Freq(MHz)	Mode	UL RB Allocation	UL RB Offset	Average Power (dbm)	Tune up limited(dBm)	MPR (dB)
20MHz	18700	1860	QPSK	1	0	22.2	21.5±1	/
				1	49	22.26	21.5±1	/
				1	99	22.04	21.5±1	/
				50	0	21.15	21.5±1	1.0
				50	24	21.18	21.5±1	1.0
				50	49	21.09	21.5±1	1.0
				100	0	20.98	21.5±1	1.0
			16QAM	1	0	21.63	21.0±1	1.0
				1	49	21.75	21.0±1	1.0
				1	99	21.53	21.0±1	1.0
				50	0	20.32	21.0±1	1.0
				50	24	20.4	21.0±1	1.0
				50	49	20.22	21.0±1	1.0
				100	0	20.21	21.0±1	1.0
	18900	1880	QPSK	1	0	22.56	22.0±1	/
				1	49	<b>22.77</b>	22.0±1	/
				1	99	22.03	22.0±1	/
				50	0	20.87	21.0±1	1.0
				50	24	21.17	21.0±1	1.0
				50	49	21.13	21.0±1	1.0
				100	0	21.06	21.0±1	1.0
			16QAM	1	0	21.44	20.8±1	1.0
				1	49	21.68	20.8±1	1.0
				1	99	21.45	20.8±1	1.0
				50	0	19.98	20.8±1	1.0
				50	24	20.28	20.8±1	1.0
				50	49	20.25	20.8±1	1.0
				100	0	20.16	20.8±1	1.0
	19100	1900	QPSK	1	0	21.91	21.0±1	/
				1	49	21.92	21.0±1	/
1				99	21.79	21.0±1	/	
50				0	20.91	21.0±1	1.0	
50				24	20.99	21.0±1	1.0	
50				49	20.56	21.0±1	1.0	
100				0	21.03	21.0±1	1.0	
16QAM			1	0	21.26	20.5±1	1.0	
			1	49	21.34	20.5±1	1.0	
			1	99	21.24	20.5±1	1.0	
			50	0	19.89	20.5±1	1.0	
			50	24	19.98	20.5±1	1.0	
			50	49	19.54	20.5±1	1.0	
			100	0	20.05	20.5±1	1.0	

**LTE Band 4:**

BW(MHz)	Ch	Freq(MHz)	Mode	UL RB Allocation	UL RB Offset	Average Power (dbm)	Tune up limited(dBm)	MPR (dB)
1.4MHz	19957	1710.7	QPSK	1	0	22.70	22.0±1	/
				1	2	22.59	22.0±1	/
				1	5	22.68	22.0±1	/
				3	0	22.5	22.0±1	/
				3	1	22.53	22.0±1	/
				3	2	22.53	22.0±1	/
			16QAM	6	0	21.46	22.0±1	1.0
				1	0	21.71	21.0±1	1.0
				1	2	21.57	21.0±1	1.0
				1	5	21.7	21.0±1	1.0
				3	0	21.45	21.0±1	1.0
				3	1	21.5	21.0±1	1.0
	20175	1732.5	QPSK	3	2	21.5	21.0±1	1.0
				6	0	20.65	21.0±1	1.0
				1	0	22.34	22.0±1	/
				1	2	22.21	22.0±1	/
				1	5	22.26	22.0±1	/
				3	0	22.16	22.0±1	/
			16QAM	3	1	22.17	22.0±1	/
				3	2	22.16	22.0±1	/
				6	0	21.25	22.0±1	1.0
				1	0	21.74	21.0±1	1.0
				1	2	21.64	21.0±1	1.0
				1	5	21.71	21.0±1	1.0
	20393	1754.3	QPSK	3	0	21.43	21.0±1	1.0
				3	1	21.45	21.0±1	1.0
				3	2	21.45	21.0±1	1.0
				6	0	20.24	21.0±1	1.0
				1	0	21.97	21.0±1	/
				1	2	21.86	21.0±1	/
16QAM			1	5	21.9	21.0±1	/	
			3	0	21.83	21.0±1	/	
			3	1	21.83	21.0±1	/	
			3	2	21.81	21.0±1	/	
			6	0	20.95	21.0±1	1.0	
			1	0	21.1	21.0±1	1.0	
16QAM	1	2	20.99	21.0±1	1.0			
	1	5	21.1	21.0±1	1.0			
	3	0	21.15	21.0±1	1.0			
	3	1	21.16	21.0±1	1.0			
	3	2	21.14	21.0±1	1.0			
	6	0	20.19	21.0±1	1.0			

BW(MHz)	Ch	Freq(MHz)	Mode	UL RB Allocation	UL RB Offset	Average Power (dbm)	Tune up limited(dBm)	MPR (dB)
3MHz	19965	1711.5	QPSK	1	0	22.49	22.0±1	/
				1	8	22.52	22.0±1	/
				1	14	22.47	22.0±1	/
				6	0	21.42	22.0±1	1.0
				6	4	21.45	22.0±1	1.0
				6	9	21.36	22.0±1	1.0
				15	0	21.4	22.0±1	1.0
			16QAM	1	0	21.24	21.0±1	1.0
				1	8	21.37	21.0±1	1.0
				1	14	21.34	21.0±1	1.0
				8	0	20.53	21.0±1	1.0
				8	4	20.62	21.0±1	1.0
				8	9	20.54	21.0±1	1.0
				15	0	20.51	21.0±1	1.0
	20175	1732.5	QPSK	1	0	22.18	22.0±1	/
				1	8	22.19	22.0±1	/
				1	14	22.11	22.0±1	/
				6	0	21.2	22.0±1	1.0
				6	4	21.25	22.0±1	1.0
				6	9	21.24	22.0±1	1.0
				15	0	21.21	22.0±1	1.0
			16QAM	1	0	21.59	21.0±1	1.0
				1	8	21.62	21.0±1	1.0
				1	14	21.56	21.0±1	1.0
				6	0	20.37	21.0±1	1.0
				6	4	20.42	21.0±1	1.0
				6	9	20.41	21.0±1	1.0
				15	0	20.32	21.0±1	1.0
	20385	1753.5	QPSK	1	0	21.91	21.0±1	/
				1	8	21.87	21.0±1	/
1				14	21.75	21.0±1	/	
6				0	20.99	21.0±1	1.0	
6				4	21	21.0±1	1.0	
6				9	20.96	21.0±1	1.0	
15				0	20.98	21.0±1	1.0	
16QAM			1	0	21	21.0±1	1.0	
			1	8	21	21.0±1	1.0	
			1	14	20.96	21.0±1	1.0	
			8	0	20.1	21.0±1	1.0	
			8	4	20.11	21.0±1	1.0	
			8	9	20.07	21.0±1	1.0	
			15	0	20.01	21.0±1	1.0	

BW(MHz)	Ch	Freq(MHz)	Mode	UL RB Allocation	UL RB Offset	Average Power (dbm)	Tune up limited(dBm)	MPR (dB)
5MHz	19975	1712.5	QPSK	1	0	22.48	22.0±1	/
				1	49	22.59	22.0±1	/
				1	99	22.44	22.0±1	/
				12	0	21.35	22.0±1	1.0
				12	24	21.4	22.0±1	1.0
				12	49	21.34	22.0±1	1.0
				25	0	21.33	22.0±1	1.0
			16QAM	1	0	21.47	21.0±1	1.0
				1	49	21.6	21.0±1	1.0
				1	99	21.48	21.0±1	1.0
				12	0	20.49	21.0±1	1.0
				12	24	20.54	21.0±1	1.0
				12	49	20.49	21.0±1	1.0
				25	0	20.42	21.0±1	1.0
	20175	1732.5	QPSK	1	0	22.15	22.0±1	/
				1	49	22.24	22.0±1	/
				1	99	22.14	22.0±1	/
				12	0	21.24	22.0±1	1.0
				12	24	21.25	22.0±1	1.0
				12	49	21.17	22.0±1	1.0
				25	0	21.19	22.0±1	1.0
			16QAM	1	0	21.65	21.0±1	1.0
				1	49	21.8	21.0±1	1.0
				1	99	21.72	21.0±1	1.0
				12	0	20.41	21.0±1	1.0
				12	24	20.49	21.0±1	1.0
				12	49	20.36	21.0±1	1.0
				25	0	20.35	21.0±1	1.0
	20375	1752.5	QPSK	1	0	21.96	21.0±1	/
				1	49	21.93	21.0±1	/
1				99	21.74	21.0±1	/	
12				0	20.98	21.0±1	1.0	
12				24	21.03	21.0±1	1.0	
12				49	20.94	21.0±1	1.0	
25				0	20.97	21.0±1	1.0	
16QAM			1	0	21.16	20.5±1	1.0	
			1	49	21.17	20.5±1	1.0	
			1	99	21.05	20.5±1	1.0	
			12	0	20.08	20.5±1	1.0	
			12	24	20.15	20.5±1	1.0	
			12	49	20.06	20.5±1	1.0	
			25	0	19.99	20.5±1	1.0	

BW(MHz)	Ch	Freq(MHz)	Mode	UL RB Allocation	UL RB Offset	Average Power (dbm)	Tune up limited(dBm)	MPR (dB)
10MHz	20000	1715	QPSK	1	0	22.34	22.0±1	/
				1	49	22.38	22.0±1	/
				1	99	22.17	22.0±1	/
				25	0	21.13	22.0±1	1.0
				25	24	21.29	22.0±1	1.0
				25	49	21.11	22.0±1	1.0
				50	0	21.15	22.0±1	1.0
			16QAM	1	0	21.12	21.0±1	1.0
				1	49	21.27	21.0±1	1.0
				1	99	21	21.0±1	1.0
				25	0	20.21	21.0±1	1.0
				25	24	20.37	21.0±1	1.0
				25	49	20.2	21.0±1	1.0
				50	0	20.21	21.0±1	1.0
	20175	1732.5	QPSK	1	0	22.02	21.5±1	/
				1	49	22.1	21.5±1	/
				1	99	21.83	21.5±1	/
				25	0	21	21.5±1	1.0
				25	24	21.12	21.5±1	1.0
				25	49	21.02	21.5±1	1.0
				50	0	20.98	21.5±1	1.0
			16QAM	1	0	21.32	21.0±1	1.0
				1	49	21.55	21.0±1	1.0
				1	99	21.27	21.0±1	1.0
				25	0	20.06	21.0±1	1.0
				25	24	20.24	21.0±1	1.0
				25	49	20.09	21.0±1	1.0
				50	0	20.1	21.0±1	1.0
	20350	1750	QPSK	1	0	21.79	21.0±1	/
				1	49	21.9	21.0±1	/
1				99	21.57	21.0±1	/	
25				0	20.83	21.0±1	1.0	
25				24	20.96	21.0±1	1.0	
25				49	20.77	21.0±1	1.0	
50				0	20.83	21.0±1	1.0	
16QAM			1	0	20.92	20.5±1	1.0	
			1	49	21.03	20.5±1	1.0	
			1	99	20.72	20.5±1	1.0	
			25	0	20.01	20.5±1	1.0	
			25	24	20.14	20.5±1	1.0	
			25	49	19.91	20.5±1	1.0	
			50	0	19.96	20.5±1	1.0	

BW(MHz)	Ch	Freq(MHz)	Mode	UL RB Allocation	UL RB Offset	Average Power (dbm)	Tune up limited(dBm)	MPR (dB)
15MHz	20025	1717.5	QPSK	1	0	22.38	22.0±1	/
				1	49	22.35	22.0±1	/
				1	99	22.16	22.0±1	/
				36	0	21.31	22.0±1	1.0
				36	24	21.31	22.0±1	1.0
				36	49	21.25	22.0±1	1.0
				75	0	21.21	21.0±1	1.0
			16QAM	1	0	21.24	21.0±1	1.0
				1	49	21.25	21.0±1	1.0
				1	99	21.13	21.0±1	1.0
				36	0	20.36	21.0±1	1.0
				36	24	20.38	21.0±1	1.0
				36	49	20.33	21.0±1	1.0
				75	0	20.29	21.0±1	1.0
	20175	1732.5	QPSK	1	0	22.25	22.0±1	/
				1	49	22.22	22.0±1	/
				1	99	21.99	22.0±1	/
				36	0	21.11	22.0±1	1.0
				36	24	21.27	22.0±1	1.0
				36	49	21.16	22.0±1	1.0
				75	0	21.16	22.0±1	1.0
			16QAM	1	0	21.56	21.0±1	1.0
				1	49	21.66	21.0±1	1.0
				1	99	21.44	21.0±1	1.0
				36	0	20.22	21.0±1	1.0
				36	24	20.36	21.0±1	1.0
				36	49	20.25	21.0±1	1.0
				75	0	20.23	21.0±1	1.0
	20325	1747.5	QPSK	1	0	21.99	21.0±1	/
				1	49	21.93	21.0±1	/
1				99	21.73	21.0±1	/	
36				0	21.06	21.0±1	1.0	
36				24	21.11	21.0±1	1.0	
36				49	21.03	21.0±1	1.0	
75				0	21	21.0±1	1.0	
16QAM			1	0	21.46	21.0±1	1.0	
			1	49	21.48	21.0±1	1.0	
			1	99	21.27	21.0±1	1.0	
			36	0	20.08	21.0±1	1.0	
			36	24	20.14	21.0±1	1.0	
			36	49	20.06	21.0±1	1.0	
			75	0	20.06	21.0±1	1.0	

BW(MHz)	Ch	Freq(MHz)	Mode	UL RB Allocation	UL RB Offset	Average Power (dbm)	Tune up limited(dBm)	MPR (dB)
20MHz	20050	1720	QPSK	1	0	<b>22.71</b>	22.0±1	/
				1	49	22.66	22.0±1	/
				1	99	22.07	22.0±1	/
				50	0	21.19	22.0±1	1.0
				50	24	21.24	22.0±1	1.0
				50	49	21.11	22.0±1	1.0
				100	0	21.11	22.0±1	1.0
			16QAM	1	0	21.77	21.0±1	1.0
				1	49	21.83	21.0±1	1.0
				1	99	21.55	21.0±1	1.0
				50	0	20.28	21.0±1	1.0
				50	24	20.33	21.0±1	1.0
				50	49	20.21	21.0±1	1.0
				100	0	20.21	21.0±1	1.0
	20175	1732.5	QPSK	1	0	22.27	22.0±1	/
				1	49	22.25	22.0±1	/
				1	99	21.96	22.0±1	/
				50	0	21.03	22.0±1	1.0
				50	24	21.23	22.0±1	1.0
				50	49	21.11	22.0±1	1.0
				100	0	21.1	22.0±1	1.0
			16QAM	1	0	21.53	21.0±1	1.0
				1	49	21.73	21.0±1	1.0
				1	99	21.45	21.0±1	1.0
				50	0	20.12	21.0±1	1.0
				50	24	20.29	21.0±1	1.0
				50	49	20.17	21.0±1	1.0
				100	0	20.15	21.0±1	1.0
	20300	1745	QPSK	1	0	21.87	21.5±1	/
				1	49	22.01	21.5±1	/
1				99	21.7	21.5±1	/	
50				0	21	21.5±1	1.0	
50				24	21.13	21.5±1	1.0	
50				49	20.97	21.5±1	1.0	
100				0	20.99	21.5±1	1.0	
16QAM			1	0	21.36	20.6±1	1.0	
			1	49	21.54	20.6±1	1.0	
			1	99	21.21	20.6±1	1.0	
			50	0	20.06	20.6±1	1.0	
			50	24	20.15	20.6±1	1.0	
			50	49	19.99	20.6±1	1.0	
			100	0	20.04	20.6±1	1.0	



**LTE Band 5:**

BW(MHz)	Ch	Freq(MHz)	Mode	UL RB Allocation	UL RB Offset	Average Power (dbm)	Tune up limited(dBm)	MPR (dB)
1.4MHz	20407	824.7	QPSK	1	0	23.45	23.0±1	/
				1	2	23.06	23.0±1	/
				1	5	23.14	23.0±1	/
				3	0	23.21	23.0±1	/
				3	1	23.01	23.0±1	/
				3	2	23.03	23.0±1	/
			16QAM	6	0	22.08	23.0±1	1.0
				1	0	22.44	22.0±1	1.0
				1	2	22.1	22.0±1	1.0
				1	5	22.26	22.0±1	1.0
				3	0	22.25	22.0±1	1.0
				3	1	22.04	22.0±1	1.0
	20525	836.5	QPSK	3	2	22.05	22.0±1	1.0
				6	0	21.17	22.0±1	1.0
				1	0	22.92	22.0±1	/
				1	2	22.82	22.0±1	/
				1	5	22.82	22.0±1	/
				3	0	22.83	22.0±1	/
			16QAM	3	1	22.79	22.0±1	/
				3	2	22.75	22.0±1	/
				6	0	21.85	22.0±1	1.0
				1	0	22.29	21.5±1	1.0
				1	2	22.18	21.5±1	1.0
				1	5	22.23	21.5±1	1.0
	20634	848.3	QPSK	3	0	22.03	21.5±1	1.0
				3	1	22	21.5±1	1.0
				3	2	21.97	21.5±1	1.0
				6	0	20.75	21.5±1	1.0
				1	0	22.85	22.0±1	/
				1	2	22.71	22.0±1	/
16QAM			1	5	22.86	22.0±1	/	
			3	0	22.62	22.0±1	/	
			3	1	22.69	22.0±1	/	
			3	2	22.67	22.0±1	/	
			6	0	21.66	22.0±1	1.0	
			1	0	21.83	21.0±1	1.0	
16QAM	1	2	21.69	21.0±1	1.0			
	1	5	21.83	21.0±1	1.0			
	3	0	21.84	21.0±1	1.0			
	3	1	21.85	21.0±1	1.0			
	3	2	21.83	21.0±1	1.0			
	6	0	20.89	21.0±1	1.0			

BW(MHz)	Ch	Freq(MHz)	Mode	UL RB Allocation	UL RB Offset	Average Power (dbm)	Tune up limited(dBm)	MPR (dB)
3MHz	20415	825.5	QPSK	1	0	23.2	23.0±1	/
				1	8	23.03	23.0±1	/
				1	14	22.92	23.0±1	/
				6	0	22.01	23.0±1	1.0
				6	4	22.08	23.0±1	1.0
				6	9	22.05	23.0±1	1.0
				15	0	22.01	23.0±1	1.0
			16QAM	1	0	22.06	22.0±1	1.0
				1	8	21.98	22.0±1	1.0
				1	14	21.89	22.0±1	1.0
				8	0	21.09	22.0±1	1.0
				8	4	21.17	22.0±1	1.0
				8	9	21.14	22.0±1	1.0
				15	0	21.04	22.0±1	1.0
				20525	836.5	QPSK	1	0
	1	8	22.81				23.0±1	/
	1	14	22.67				23.0±1	/
	6	0	21.91				23.0±1	1.0
	6	4	21.87				23.0±1	1.0
	6	9	21.79				23.0±1	1.0
	15	0	21.83				23.0±1	1.0
	16QAM	1	0			22.25	21.5±1	1.0
		1	8			22.17	21.5±1	1.0
		1	14			22.09	21.5±1	1.0
		6	0			20.98	21.5±1	1.0
		6	4			20.95	21.5±1	1.0
		6	9			20.87	21.5±1	1.0
		15	0			20.88	21.5±1	1.0
		20635	847.5			QPSK	1	0
	1			8	22.75		22.0±1	/
1	14			22.7	22.0±1		/	
6	0			21.7	22.0±1		1.0	
6	4			21.75	22.0±1		1.0	
6	9			21.68	22.0±1		1.0	
15	0			21.66	22.0±1		1.0	
16QAM	1			0	21.54	21.0±1	1.0	
	1			8	21.78	21.0±1	1.0	
	1			14	21.71	21.0±1	1.0	
	8			0	20.73	21.0±1	1.0	
	8			4	20.84	21.0±1	1.0	
	8			9	20.77	21.0±1	1.0	
	15			0	20.63	21.0±1	1.0	

BW(MHz)	Ch	Freq(MHz)	Mode	UL RB Allocation	UL RB Offset	Average Power (dbm)	Tune up limited(dBm)	MPR (dB)
5MHz	20425	826.5	QPSK	1	0	23.2	22.5±1	/
				1	49	23.05	22.5±1	/
				1	99	22.7	22.5±1	/
				12	0	21.97	22.5±1	1.0
				12	24	22	22.5±1	1.0
				12	49	21.92	22.5±1	1.0
				25	0	21.91	22.5±1	1.0
			16QAM	1	0	22.24	21.5±1	1.0
				1	49	22.17	21.5±1	1.0
				1	99	21.89	21.5±1	1.0
				12	0	21.03	21.5±1	1.0
				12	24	21.06	21.5±1	1.0
				12	49	20.98	21.5±1	1.0
				25	0	20.92	22.0±1	1.0
	20525	836.5	QPSK	1	0	22.9	22.0±1	/
				1	49	22.84	22.0±1	/
				1	99	22.59	22.0±1	/
				12	0	21.91	22.0±1	1.0
				12	24	21.86	22.0±1	1.0
				12	49	21.77	22.0±1	1.0
				25	0	21.8	22.0±1	1.0
			16QAM	1	0	22.33	21.5±1	1.0
				1	49	22.34	21.5±1	1.0
				1	99	22.14	21.5±1	1.0
				12	0	21.05	21.5±1	1.0
				12	24	21.01	21.5±1	1.0
				12	49	20.92	21.5±1	1.0
25				0	20.88	21.5±1	1.0	
20625	846.5	QPSK	1	0	22.34	22.0±1	/	
			1	49	22.67	22.0±1	/	
			1	99	22.72	22.0±1	/	
			12	0	21.44	22.0±1	1.0	
			12	24	21.63	22.0±1	1.0	
			12	49	21.62	22.0±1	1.0	
			25	0	21.53	22.0±1	1.0	
		16QAM	1	0	21.46	21.0±1	1.0	
			1	49	21.78	21.0±1	1.0	
			1	99	21.79	21.0±1	1.0	
			12	0	20.48	21.0±1	1.0	
			12	24	20.73	21.0±1	1.0	
			12	49	20.68	21.0±1	1.0	
			25	0	20.54	21.0±1	1.0	

BW(MHz)	Ch	Freq(MHz)	Mode	UL RB Allocation	UL RB Offset	Average Power (dbm)	Tune up limited(dBm)	MPR (dB)
10MHz	20450	829	QPSK	1	0	<b>23.48</b>	22.5±1	/
				1	49	22.92	22.5±1	/
				1	99	22.6	22.5±1	/
				25	0	21.7	22.5±1	1.0
				25	24	21.66	22.5±1	1.0
				25	49	21.55	22.5±1	1.0
				50	0	21.68	22.5±1	1.0
			16QAM	1	0	21.76	21.0±1	1.0
				1	49	21.53	21.0±1	1.0
				1	99	21.53	21.0±1	1.0
				25	0	20.71	21.0±1	1.0
				25	24	20.67	21.0±1	1.0
				25	49	20.57	21.0±1	1.0
				50	0	20.66	21.0±1	1.0
	20525	836.5	QPSK	1	0	22.64	22.0±1	/
				1	49	22.66	22.0±1	/
				1	99	22.11	22.0±1	/
				25	0	21.6	22.0±1	1.0
				25	24	21.7	22.0±1	1.0
				25	49	21.47	22.0±1	1.0
				50	0	21.49	22.0±1	1.0
			16QAM	1	0	21.99	21.6±1	1.0
				1	49	22.07	21.6±1	1.0
				1	99	21.54	21.6±1	1.0
				25	0	20.62	21.6±1	1.0
				25	24	20.73	21.6±1	1.0
				25	49	20.52	21.6±1	1.0
				50	0	20.52	21.6±1	1.0
	20600	844	QPSK	1	0	22.23	22.0±1	/
				1	49	22.26	22.0±1	/
1				99	22.47	22.0±1	/	
25				0	21.2	22.0±1	1.0	
25				24	21.31	22.0±1	1.0	
25				49	21.22	22.0±1	1.0	
50				0	21.25	22.0±1	1.0	
16QAM			1	0	21.25	21.0±1	1.0	
			1	49	21.28	21.0±1	1.0	
			1	99	21.39	21.0±1	1.0	
			25	0	20.32	21.0±1	1.0	
			25	24	20.42	21.0±1	1.0	
			25	49	20.36	21.0±1	1.0	
			50	0	20.31	21.0±1	1.0	

**LTE Band 12:**

BW(MHz)	Ch	Freq(MHz)	Mode	UL RB Allocation	UL RB Offset	Average Power (dbm)	Tune up limited(dBm)	MPR (dB)
1.4MHz	23017	699.7	QPSK	1	0	22.89	22.5±1	/
				1	2	22.99	22.5±1	/
				1	5	23.11	22.5±1	/
				3	0	22.83	22.5±1	/
				3	1	22.91	22.5±1	/
				3	2	22.94	22.5±1	/
			16QAM	6	0	21.81	22.5±1	1.0
				1	0	21.84	21.5±1	1.0
				1	2	21.89	21.5±1	1.0
				1	5	22.21	21.5±1	1.0
				3	0	21.76	21.5±1	1.0
				3	1	21.85	21.5±1	1.0
	23095	707.5	QPSK	3	2	21.92	21.5±1	1.0
				6	0	20.88	21.5±1	1.0
				1	0	23	22.5±1	/
				1	2	22.72	22.5±1	/
				1	5	22.84	22.5±1	/
				3	0	22.77	22.5±1	/
			16QAM	3	1	22.67	22.5±1	/
				3	2	22.71	22.5±1	/
				6	0	21.85	22.5±1	1.0
				1	0	22.43	21.5±1	1.0
				1	2	22.18	21.5±1	1.0
				1	5	22.22	21.5±1	1.0
	23173	715.3	QPSK	3	0	22.07	21.5±1	1.0
				3	1	21.98	21.5±1	1.0
				3	2	21.95	21.5±1	1.0
				6	0	20.68	21.5±1	1.0
				1	0	23.02	22.5±1	/
				1	2	22.73	22.5±1	/
16QAM			1	5	22.72	22.5±1	/	
			3	0	22.75	22.5±1	/	
			3	1	22.67	22.5±1	/	
			3	2	22.59	22.5±1	/	
			6	0	21.61	22.5±1	1.0	
			1	0	21.88	21.0±1	1.0	
16QAM	1	2	21.68	21.0±1	1.0			
	1	5	21.66	21.0±1	1.0			
	3	0	21.89	21.0±1	1.0			
	3	1	21.82	21.0±1	1.0			
	3	2	21.76	21.0±1	1.0			
	6	0	20.78	21.0±1	1.0			

BW(MHz)	Ch	Freq(MHz)	Mode	UL RB Allocation	UL RB Offset	Average Power (dbm)	Tune up limited(dBm)	MPR (dB)
3MHz	23025	700.5	QPSK	1	0	22.72	22.5±1	/
				1	8	23.07	22.5±1	/
				1	14	22.89	22.5±1	/
				8	0	21.87	22.5±1	1.0
				8	4	21.97	22.5±1	1.0
				8	9	21.94	22.5±1	1.0
				15	0	21.85	22.5±1	1.0
			16QAM	1	0	21.49	21.0±1	1.0
				1	8	21.89	21.0±1	1.0
				1	14	21.82	21.0±1	1.0
				8	0	20.87	21.0±1	1.0
				8	4	20.99	21.0±1	1.0
				8	9	20.96	21.0±1	1.0
				15	0	20.81	21.0±1	1.0
	23095	707.5	QPSK	1	0	22.76	22.0±1	/
				1	8	22.65	22.0±1	/
				1	14	22.55	22.0±1	/
				8	0	21.79	22.0±1	1.0
				8	4	21.79	22.0±1	1.0
				8	9	21.76	22.0±1	1.0
				15	0	21.73	22.0±1	1.0
			16QAM	1	0	22.18	21.5±1	1.0
				1	8	22.13	21.5±1	1.0
				1	14	22.04	21.5±1	1.0
				8	0	20.9	21.5±1	1.0
				8	4	20.85	21.5±1	1.0
				8	9	20.77	21.5±1	1.0
				15	0	20.71	21.5±1	1.0
	23165	714.5	QPSK	1	0	22.85	22.0±1	/
				1	8	22.79	22.0±1	/
1				14	22.49	22.0±1	/	
8				0	21.76	22.0±1	1.0	
8				4	21.75	22.0±1	1.0	
8				9	21.64	22.0±1	1.0	
15				0	21.69	22.0±1	1.0	
16QAM			1	0	21.68	21.0±1	1.0	
			1	8	21.76	21.0±1	1.0	
			1	14	21.41	21.0±1	1.0	
			8	0	20.7	21.0±1	1.0	
			8	4	20.7	21.0±1	1.0	
			8	9	20.6	21.0±1	1.0	
			15	0	20.56	21.0±1	1.0	

BW(MHz)	Ch	Freq(MHz)	Mode	UL RB Allocation	UL RB Offset	Average Power (dbm)	Tune up limited(dBm)	MPR (dB)
5MHz	23035	701.5	QPSK	1	0	22.78	22.0±1	/
				1	49	22.97	22.0±1	/
				1	99	22.93	22.0±1	/
				12	0	21.84	22.0±1	1.0
				12	24	21.91	22.0±1	1.0
				12	49	21.94	22.0±1	1.0
				25	0	21.84	22.0±1	1.0
			16QAM	1	0	21.81	21.5±1	1.0
				1	49	22.16	21.5±1	1.0
				1	99	22.15	21.5±1	1.0
				12	0	20.92	21.5±1	1.0
				12	24	20.95	21.5±1	1.0
				12	49	20.94	21.5±1	1.0
				25	0	20.81	21.5±1	1.0
	23095	707.5	QPSK	1	0	22.87	22.0±1	/
				1	49	22.71	22.0±1	/
				1	99	22.58	22.0±1	/
				12	0	21.73	22.0±1	1.0
				12	24	21.7	22.0±1	1.0
				12	49	21.68	22.0±1	1.0
				25	0	21.59	22.0±1	1.0
			16QAM	1	0	22.34	21.5±1	1.0
				1	49	22.24	21.5±1	1.0
				1	99	22.13	21.5±1	1.0
				12	0	20.77	21.5±1	1.0
				12	24	20.8	21.5±1	1.0
				12	49	20.74	21.5±1	1.0
25				0	20.62	21.5±1	1.0	
23155	713.5	QPSK	1	0	22.58	22.0±1	/	
			1	49	22.88	22.0±1	/	
			1	99	22.52	22.0±1	/	
			12	0	21.57	22.0±1	1.0	
			12	24	21.74	22.0±1	1.0	
			12	49	21.64	22.0±1	1.0	
			25	0	21.66	22.0±1	1.0	
		16QAM	1	0	21.62	21.0±1	1.0	
			1	49	21.91	21.0±1	1.0	
			1	99	21.54	21.0±1	1.0	
			12	0	20.61	21.0±1	1.0	
			12	24	20.77	21.0±1	1.0	
			12	49	20.64	21.0±1	1.0	
			25	0	20.61	21.0±1	1.0	

BW(MHz)	Ch	Freq(MHz)	Mode	UL RB Allocation	UL RB Offset	Average Power (dbm)	Tune up limited(dBm)	MPR (dB)
10MHz	23060	704	QPSK	1	0	22.61	22.3±1	/
				1	49	<b>23.15</b>	22.3±1	/
				1	99	22.94	22.3±1	/
				25	0	21.6	22.3±1	1.0
				25	24	21.6	22.3±1	1.0
				25	49	21.33	22.3±1	1.0
				50	0	21.35	22.3±1	1.0
			16QAM	1	0	21.38	21.0±1	1.0
				1	49	21.69	21.0±1	1.0
				1	99	21.07	21.0±1	1.0
				25	0	20.5	21.0±1	1.0
				25	24	20.56	21.0±1	1.0
				25	49	20.25	21.0±1	1.0
				50	0	20.23	21.0±1	1.0
	23095	707.5	QPSK	1	0	22.55	22.0±1	/
				1	49	22.39	22.0±1	/
				1	99	22.22	22.0±1	/
				25	0	21.43	22.0±1	1.0
				25	24	21.33	22.0±1	1.0
				25	49	21.24	22.0±1	1.0
				50	0	21.05	22.0±1	1.0
			16QAM	1	0	21.88	21.0±1	1.0
				1	49	21.79	21.0±1	1.0
				1	99	21.5	21.0±1	1.0
				25	0	20.35	21.0±1	1.0
				25	24	20.35	21.0±1	1.0
				25	49	20.26	21.0±1	1.0
				50	0	20.07	21.0±1	1.0
	23130	711	QPSK	1	0	22.46	22.0±1	/
				1	49	22.34	22.0±1	/
1				99	22.32	22.0±1	/	
25				0	21.32	22.0±1	1.0	
25				24	21.39	22.0±1	1.0	
25				49	21.31	22.0±1	1.0	
50				0	21.41	22.0±1	1.0	
16QAM			1	0	21.48	21.0±1	1.0	
			1	49	21.36	21.0±1	1.0	
			1	99	21.26	21.0±1	1.0	
			25	0	20.36	21.0±1	1.0	
			25	24	20.43	21.0±1	1.0	
			25	49	20.44	21.0±1	1.0	
			50	0	20.41	21.0±1	1.0	



**LTE Band 13:**

BW(MHz)	Ch	Freq(MHz)	Mode	UL RB Allocation	UL RB Offset	Average Power (dbm)	Tune up limited(dBm)	MPR (dB)
5MHz	23205	779.5	QPSK	1	0	22.95	22.0±1	/
				1	49	22.94	22.0±1	/
				1	99	22.87	22.0±1	/
				12	0	21.88	22.0±1	1.0
				12	24	21.89	22.0±1	1.0
				12	49	21.86	22.0±1	1.0
				25	0	21.84	22.0±1	1.0
			16QAM	1	0	22.06	21.5±1	1.0
				1	49	22.01	21.5±1	1.0
				1	99	21.97	21.5±1	1.0
				12	0	20.96	21.5±1	1.0
				12	24	20.97	21.5±1	1.0
				12	49	20.95	21.5±1	1.0
				25	0	20.83	21.5±1	1.0
	23230	782.0	QPSK	1	0	22.92	22.0±1	/
				1	49	22.9	22.0±1	/
				1	99	22.89	22.0±1	/
				12	0	21.83	22.0±1	1.0
				12	24	21.83	22.0±1	1.0
				12	49	21.84	22.0±1	1.0
				25	0	21.71	22.0±1	1.0
			16QAM	1	0	22.02	21.5±1	1.0
				1	49	22.06	21.5±1	1.0
				1	99	22.08	21.5±1	1.0
				12	0	20.95	21.5±1	1.0
				12	24	20.96	21.5±1	1.0
				12	49	20.97	21.5±1	1.0
25				0	20.78	21.5±1	1.0	
23255	784.5	QPSK	1	0	22.91	22.0±1	/	
			1	49	22.95	22.0±1	/	
			1	99	22.96	22.0±1	/	
			12	0	21.97	22.0±1	1.0	
			12	24	21.98	22.0±1	1.0	
			12	49	21.87	22.0±1	1.0	
			25	0	21.95	22.0±1	1.0	
		16QAM	1	0	22.35	22.0±1	1.0	
			1	49	22.47	22.0±1	1.0	
			1	99	22.46	22.0±1	1.0	
			12	0	21.12	22.0±1	1.0	
			12	24	21.14	22.0±1	1.0	
			12	49	21.03	22.0±1	1.0	
			25	0	21.03	22.0±1	1.0	

BW(MHz)	Ch	Freq(MHz)	Mode	UL RB Allocation	UL RB Offset	Average Power (dbm)	Tune up limited(dBm)	MPR (dB)
10MHz	23230	782.0	QPSK	1	0	22.78	22.0±1	/
				1	49	<b>22.98</b>	22.0±1	/
				1	99	22.84	22.0±1	/
				25	0	21.49	22.0±1	1.0
				25	24	21.48	22.0±1	1.0
				25	49	21.54	22.0±1	1.0
				50	0	21.17	22.0±1	1.0
			16QAM	1	0	21.47	21.0±1	1.0
				1	49	21.57	21.0±1	1.0
				1	99	21.5	21.0±1	1.0
				25	0	20.57	21.0±1	1.0
				25	24	20.56	21.0±1	1.0
				25	49	20.62	21.0±1	1.0
				50	0	20.23	21.0±1	1.0

**LTE Band 66:**

BW(MHz)	Ch	Freq(MHz)	Mode	UL RB Allocation	UL RB Offset	Average Power (dbm)	Tune up limited(dBm)	MPR (dB)
1.4MHz	131979	1710.7	QPSK	1	0	22.75	22.0±1	/
				1	2	22.63	22.0±1	/
				1	5	22.76	22.0±1	/
				3	0	22.58	22.0±1	/
				3	1	22.57	22.0±1	/
				3	2	22.56	22.0±1	/
			16QAM	6	0	21.46	22.0±1	1.0
				1	0	21.71	21.0±1	1.0
				1	2	21.58	21.0±1	1.0
				1	5	21.75	21.0±1	1.0
				3	0	21.45	21.0±1	1.0
				3	1	21.5	21.0±1	1.0
	132321	1744.9	QPSK	3	2	21.5	21.0±1	1.0
				6	0	20.61	21.0±1	1.0
				1	0	22.37	22.0±1	/
				1	2	22.28	22.0±1	/
				1	5	22.28	22.0±1	/
				3	0	22.24	22.0±1	/
			16QAM	3	1	22.24	22.0±1	/
				3	2	22.23	22.0±1	/
				6	0	21.27	22.0±1	1.0
				1	0	21.7	21.0±1	1.0
				1	2	21.64	21.0±1	1.0
				1	5	21.7	21.0±1	1.0
	132664	1779.2	QPSK	3	0	21.44	21.0±1	1.0
				3	1	21.45	21.0±1	1.0
				3	2	21.45	21.0±1	1.0
				6	0	20.18	21.0±1	1.0
				1	0	21.81	21.0±1	/
				1	2	21.53	21.0±1	/
16QAM			1	5	21.61	21.0±1	/	
			3	0	21.58	21.0±1	/	
			3	1	21.53	21.0±1	/	
			3	2	21.5	21.0±1	/	
			6	0	20.55	21.0±1	1.0	
			1	0	20.77	20.0±1	1.0	
16QAM	1	2	20.6	20.0±1	1.0			
	1	5	20.68	20.0±1	1.0			
	3	0	20.81	20.0±1	1.0			
	3	1	20.78	20.0±1	1.0			
	3	2	20.75	20.0±1	1.0			
	6	0	19.84	20.0±1	1.0			

BW(MHz)	Ch	Freq(MHz)	Mode	UL RB Allocation	UL RB Offset	Average Power (dbm)	Tune up limited(dBm)	MPR (dB)
3MHz	131987	1711.5	QPSK	1	0	22.52	22.0±1	/
				1	8	22.64	22.0±1	/
				1	14	22.6	22.0±1	/
				6	0	21.48	22.0±1	1.0
				6	4	21.57	22.0±1	1.0
				6	9	21.51	22.0±1	1.0
			16QAM	15	0	21.51	22.0±1	1.0
				1	0	21.34	21.0±1	1.0
				1	8	21.48	21.0±1	1.0
				1	14	21.45	21.0±1	1.0
				8	0	20.56	21.0±1	1.0
				8	4	20.63	21.0±1	1.0
	132321	1744.9	QPSK	8	9	20.65	21.0±1	1.0
				15	0	20.52	21.0±1	1.0
				1	0	22.28	22.0±1	/
				1	8	22.3	22.0±1	/
				1	14	22.2	22.0±1	/
				6	0	21.33	22.0±1	1.0
			16QAM	6	4	21.37	22.0±1	1.0
				6	9	21.34	22.0±1	1.0
				15	0	21.33	22.0±1	1.0
				1	0	21.65	21.0±1	1.0
				1	8	21.7	21.0±1	1.0
				1	14	21.62	21.0±1	1.0
	132656	1778.4	QPSK	6	0	20.42	21.0±1	1.0
				6	4	20.45	21.0±1	1.0
				6	9	20.43	21.0±1	1.0
15				0	20.36	21.0±1	1.0	
1				0	21.91	21.0±1	/	
1				8	21.67	21.0±1	/	
16QAM			1	14	21.51	21.0±1	/	
			6	0	20.74	21.0±1	1.0	
			6	4	20.68	21.0±1	1.0	
			6	9	20.59	21.0±1	1.0	
			15	0	20.66	21.0±1	1.0	
			1	0	20.78	20.0±1	1.0	
16QAM	1	8	20.7	20.0±1	1.0			
	1	14	20.49	20.0±1	1.0			
	8	0	19.88	20.0±1	1.0			
	8	4	19.83	20.0±1	1.0			
	8	9	19.74	20.0±1	1.0			
	15	0	19.74	20.0±1	1.0			

BW(MHz)	Ch	Freq(MHz)	Mode	UL RB Allocation	UL RB Offset	Average Power (dbm)	Tune up limited(dBm)	MPR (dB)
5MHz	131997	1712.5	QPSK	1	0	22.55	22.0±1	/
				1	49	22.69	22.0±1	/
				1	99	22.71	22.0±1	/
				12	0	21.44	22.0±1	1.0
				12	24	21.53	22.0±1	1.0
				12	49	21.52	22.0±1	1.0
				25	0	21.46	22.0±1	1.0
			16QAM	1	0	21.53	21.0±1	1.0
				1	49	21.73	21.0±1	1.0
				1	99	21.77	21.0±1	1.0
				12	0	20.49	21.0±1	1.0
				12	24	20.63	21.0±1	1.0
				12	49	20.63	21.0±1	1.0
				25	0	20.51	21.0±1	1.0
	132321	1744.9	QPSK	1	0	22.26	22.0±1	/
				1	49	22.32	22.0±1	/
				1	99	22.14	22.0±1	/
				12	0	21.27	22.0±1	1.0
				12	24	21.35	22.0±1	1.0
				12	49	21.29	22.0±1	1.0
				25	0	21.29	22.0±1	1.0
			16QAM	1	0	21.7	21.0±1	1.0
				1	49	21.86	21.0±1	1.0
				1	99	21.69	21.0±1	1.0
				12	0	20.42	21.0±1	1.0
				12	24	20.5	21.0±1	1.0
				12	49	20.45	21.0±1	1.0
25				0	20.37	21.0±1	1.0	
132646	1777.4	QPSK	1	0	22.07	21.5±1	/	
			1	49	21.8	21.5±1	/	
			1	99	21.49	21.5±1	/	
			12	0	20.86	21.5±1	1.0	
			12	24	20.79	21.5±1	1.0	
			12	49	20.59	21.5±1	1.0	
			25	0	20.73	21.5±1	1.0	
		16QAM	1	0	21.09	20.5±1	1.0	
			1	49	20.94	20.5±1	1.0	
			1	99	20.62	20.5±1	1.0	
			12	0	20.01	20.5±1	1.0	
			12	24	19.96	20.5±1	1.0	
			12	49	19.77	20.5±1	1.0	
			25	0	19.81	20.5±1	1.0	

BW(MHz)	Ch	Freq(MHz)	Mode	UL RB Allocation	UL RB Offset	Average Power (dbm)	Tune up limited(dBm)	MPR (dB)
10MHz	132022	1715	QPSK	1	0	22.43	22.0±1	/
				1	49	22.66	22.0±1	/
				1	99	22.55	22.0±1	/
				25	0	21.26	22.0±1	1.0
				25	24	21.47	22.0±1	1.0
				25	49	21.44	22.0±1	1.0
			16QAM	50	0	21.33	22.0±1	1.0
				1	0	21.18	21.0±1	1.0
				1	49	21.44	21.0±1	1.0
				1	99	21.38	21.0±1	1.0
				25	0	20.31	21.0±1	1.0
				25	24	20.52	21.0±1	1.0
	132321	1744.9	QPSK	25	49	20.39	21.0±1	1.0
				50	0	20.35	21.0±1	1.0
				1	0	22.08	22.0±1	/
				1	49	22.2	22.0±1	/
				1	99	21.9	22.0±1	/
				25	0	21.11	22.0±1	1.0
			16QAM	25	24	21.22	22.0±1	1.0
				25	49	21.02	22.0±1	1.0
				50	0	21.09	22.0±1	1.0
				1	0	21.4	21.0±1	1.0
				1	49	21.61	21.0±1	1.0
				1	99	21.33	21.0±1	1.0
	132621	1774.9	QPSK	25	0	20.15	21.0±1	1.0
				25	24	20.26	21.0±1	1.0
				25	49	20.06	21.0±1	1.0
				50	0	20.13	21.0±1	1.0
				1	0	21.84	21.0±1	/
				1	49	21.99	21.0±1	/
16QAM			1	99	21.43	21.0±1	/	
			25	0	20.74	21.0±1	1.0	
			25	24	20.92	21.0±1	1.0	
			25	49	20.61	21.0±1	1.0	
			50	0	20.79	21.0±1	1.0	
			1	0	20.75	20.5±1	1.0	
16QAM	1	49	21.01	20.5±1	1.0			
	1	99	20.37	20.5±1	1.0			
	25	0	19.91	20.5±1	1.0			
	25	24	20.11	20.5±1	1.0			
	25	49	19.8	20.5±1	1.0			
	50	0	19.93	20.5±1	1.0			

BW(MHz)	Ch	Freq(MHz)	Mode	UL RB Allocation	UL RB Offset	Average Power (dbm)	Tune up limited(dBm)	MPR (dB)
15MHz	132097	1722.5	QPSK	1	0	22.47	22.0±1	/
				1	49	22.64	22.0±1	/
				1	99	22.65	22.0±1	/
				36	0	21.5	22.0±1	1.0
				36	24	21.63	22.0±1	1.0
				36	49	21.67	22.0±1	1.0
				75	0	21.53	22.0±1	1.0
			16QAM	1	0	21.26	21.0±1	1.0
				1	49	21.56	21.0±1	1.0
				1	99	21.49	21.0±1	1.0
				36	0	20.45	21.0±1	1.0
				36	24	20.67	21.0±1	1.0
				36	49	20.65	21.0±1	1.0
				75	0	20.57	21.0±1	1.0
	132321	1744.9	QPSK	1	0	22.18	22.0±1	/
				1	49	22.22	22.0±1	/
				1	99	22.09	22.0±1	/
				36	0	21.22	22.0±1	1.0
				36	24	21.26	22.0±1	1.0
				36	49	21.12	22.0±1	1.0
				75	0	21.17	22.0±1	1.0
			16QAM	1	0	21.56	21.0±1	1.0
				1	49	21.64	21.0±1	1.0
				1	99	21.44	21.0±1	1.0
				36	0	20.26	21.0±1	1.0
				36	24	20.33	21.0±1	1.0
				36	49	20.19	21.0±1	1.0
				75	0	20.21	21.0±1	1.0
	132546	1767.4	QPSK	1	0	21.99	21.0±1	/
				1	49	21.99	21.0±1	/
1				99	21.56	21.0±1	/	
36				0	20.9	21.0±1	1.0	
36				24	21	21.0±1	1.0	
36				49	20.91	21.0±1	1.0	
75				0	20.9	21.0±1	1.0	
16QAM			1	0	21.38	20.5±1	1.0	
			1	49	21.43	20.5±1	1.0	
			1	99	20.97	20.5±1	1.0	
			36	0	19.9	20.5±1	1.0	
			36	24	20.07	20.5±1	1.0	
			36	49	19.95	20.5±1	1.0	
			75	0	19.98	20.5±1	1.0	

BW(MHz)	Ch	Freq(MHz)	Mode	UL RB Allocation	UL RB Offset	Average Power (dbm)	Tune up limited(dBm)	MPR (dB)
20MHz	132072	1720	QPSK	1	0	22.5	22.0±1	/
				1	49	<b>22.78</b>	22.0±1	/
				1	99	22.35	22.0±1	/
				50	0	21.36	22.0±1	1.0
				50	24	21.65	22.0±1	1.0
				50	49	21.37	22.0±1	1.0
				100	0	21.52	22.0±1	1.0
			16QAM	1	0	21.81	21.3±1	1.0
				1	49	22.18	21.3±1	1.0
				1	99	21.81	21.3±1	1.0
				50	0	20.41	21.3±1	1.0
				50	24	20.62	21.3±1	1.0
				50	49	20.45	21.3±1	1.0
				100	0	20.49	21.3±1	1.0
	132321	1744.9	QPSK	1	0	22.2	21.5±1	/
				1	49	22.24	21.5±1	/
				1	99	22	21.5±1	/
				50	0	21.09	21.5±1	1.0
				50	24	21.24	21.5±1	1.0
				50	49	20.99	21.5±1	1.0
				100	0	21.09	21.5±1	1.0
			16QAM	1	0	21.58	21.0±1	1.0
				1	49	21.7	21.0±1	1.0
				1	99	21.43	21.0±1	1.0
				50	0	20.12	21.0±1	1.0
				50	24	20.27	21.0±1	1.0
				50	49	20.03	21.0±1	1.0
				100	0	20.11	21.0±1	1.0
	132471	1759.9	QPSK	1	0	21.96	21.0±1	/
				1	49	21.9	21.0±1	/
1				99	21.47	21.0±1	/	
50				0	20.83	21.0±1	1.0	
50				24	20.87	21.0±1	1.0	
50				49	20.82	21.0±1	1.0	
100				0	20.71	21.0±1	1.0	
16QAM			1	0	21.21	20.5±1	1.0	
			1	49	21.32	20.5±1	1.0	
			1	99	20.85	20.5±1	1.0	
			50	0	19.82	20.5±1	1.0	
			50	24	19.94	20.5±1	1.0	
			50	49	19.91	20.5±1	1.0	
			100	0	19.81	20.5±1	1.0	



**ERP and EIRP****LTE Band 2**

Frequency (MHz)	Receiver Reading (dBμV)	Turn table Angle Degree	RX Antenna		Substituted			Absolute Level (dBm)	Part 24E	
			Height (m)	Polar (H/V)	SG Level (dBm)	Cable (dB)	Antenna Gain (dB)		Limit (dBm)	Margin (dB)
LTE Band 2 Channel 18607 – 1.4MHz – QPSK										
1850.7	85.79	270	1.6	H	11.82	0.31	10.40	21.91	33	-11.09
1850.7	85.75	233	2.0	V	12.47	0.31	10.40	22.56	33	-10.44
LTE Band 2 Channel 18900 – 1.4MHz – QPSK										
1880	85.92	73	1.8	H	12.07	0.31	10.40	22.16	33	-10.84
1880	85.63	178	1.4	V	12.51	0.31	10.40	22.60	33	-10.40
LTE Band 2 Channel 19193 – 1.4MHz – QPSK										
1909.3	85.72	48	1.7	H	11.99	0.32	10.40	22.07	33	-10.93
1909.3	86.02	38	2.3	V	13.06	0.32	10.40	23.14	33	-9.86
LTE Band 2 Channel 18607 – 1.4MHz – 16QAM										
1850.7	86.04	340	1.7	H	12.07	0.31	10.40	22.16	33	-10.84
1850.7	86.01	110	2.1	V	12.73	0.31	10.40	22.82	33	-10.18
LTE Band 2 Channel 18900 – 1.4MHz – 16QAM										
1880	85.68	124	2.0	H	11.83	0.31	10.40	21.92	33	-11.08
1880	85.50	321	2.0	V	12.38	0.31	10.40	22.47	33	-10.53
LTE Band 2 Channel 19193 – 1.4MHz – 16QAM										
1909.3	85.50	272	1.1	H	11.77	0.32	10.40	21.85	33	-11.15
1909.3	85.82	308	1.2	V	12.86	0.32	10.40	22.94	33	-10.06
LTE Band 2 Channel 18615 – 3MHz – QPSK										
1851.5	85.37	194	1.8	H	11.40	0.31	10.40	21.49	33	-11.51
1851.5	85.84	272	2.2	V	12.56	0.31	10.40	22.65	33	-10.35
LTE Band 2 Channel 18900 – 3MHz – QPSK										
1880	85.60	221	2.3	H	11.75	0.31	10.40	21.84	33	-11.16
1880	85.48	324	2.2	V	12.36	0.31	10.40	22.45	33	-10.55
LTE Band 2 Channel 19185 – 3MHz – QPSK										
1908.5	85.53	198	1.8	H	11.80	0.32	10.40	21.88	33	-11.12
1908.5	86.03	273	2.2	V	13.07	0.32	10.40	23.15	33	-9.85
LTE Band 2 Channel 18615 – 3MHz – 16QAM										
1851.5	85.86	290	1.6	H	11.89	0.31	10.40	21.98	33	-11.02
1851.5	86.01	289	1.9	V	12.73	0.31	10.40	22.82	33	-10.18
LTE Band 2 Channel 18900 – 3MHz – 16QAM										
1880	85.62	325	1.3	H	11.77	0.31	10.40	21.86	33	-11.14
1880	85.82	140	1.6	V	12.70	0.31	10.40	22.79	33	-10.21
LTE Band 2 Channel 19185 – 3MHz – 16QAM										
1908.5	85.83	304	2.0	H	12.10	0.32	10.40	22.18	33	-10.82
1908.5	86.07	51	1.2	V	13.11	0.32	10.40	23.19	33	-9.81
LTE Band 2 Channel 18625 – 5MHz – QPSK										
1852.5	85.65	13	2.3	H	11.68	0.31	10.40	21.77	33	-11.23
1852.5	85.79	160	1.2	V	12.51	0.31	10.40	22.60	33	-10.40

LTE Band 2 Channel 18900 – 5MHz – QPSK										
1880	85.65	240	1.9	H	11.80	0.31	10.40	21.89	33	-11.11
1880	85.64	357	1.0	V	12.52	0.31	10.40	22.61	33	-10.39
LTE Band 2 Channel 19175 – 5MHz – QPSK										
1907.5	85.74	329	1.1	H	12.01	0.32	10.40	22.09	33	-10.91
1907.5	85.60	68	1.1	V	12.64	0.32	10.40	22.72	33	-10.28
LTE Band 2 Channel 18625 – 5MHz – 16QAM										
1852.5	85.44	271	2.1	H	11.47	0.31	10.40	21.56	33	-11.44
1852.5	86.03	201	1.5	V	12.75	0.31	10.40	22.84	33	-10.16
LTE Band 2 Channel 18900 – 5MHz – 16QAM										
1880	85.98	109	1.4	H	12.13	0.31	10.40	22.22	33	-10.78
1880	85.75	62	2.3	V	12.63	0.31	10.40	22.72	33	-10.28
LTE Band 2 Channel 19175 – 5MHz – 16QAM										
1907.5	86.01	107	1.0	H	12.28	0.32	10.40	22.36	33	-10.64
1907.5	85.91	7	1.6	V	12.95	0.32	10.40	23.03	33	-9.97
LTE Band 2 Channel 18650 – 10MHz – QPSK										
1855	85.63	176	2.0	H	11.66	0.31	10.40	21.75	33	-11.25
1855	85.91	112	1.9	V	12.63	0.31	10.40	22.72	33	-10.28
LTE Band 2 Channel 18900 – 10MHz – QPSK										
1880	85.97	294	1.1	H	12.12	0.31	10.40	22.21	33	-10.79
1880	85.52	123	2.0	V	12.40	0.31	10.40	22.49	33	-10.51
LTE Band 2 Channel 19150 – 10MHz – QPSK										
1905	85.74	304	2.0	H	12.01	0.32	10.40	22.09	33	-10.91
1905	86.13	47	1.5	V	13.17	0.32	10.40	23.25	33	-9.75
LTE Band 2 Channel 18650 – 10MHz – 16QAM										
1855	85.59	254	1.3	H	11.62	0.31	10.40	21.71	33	-11.29
1855	85.45	27	1.4	V	12.17	0.31	10.40	22.26	33	-10.74
LTE Band 2 Channel 18900 – 10MHz – 16QAM										
1880	85.91	75	2.1	H	12.06	0.31	10.40	22.15	33	-10.85
1880	85.81	214	1.5	V	12.69	0.31	10.40	22.78	33	-10.22
LTE Band 2 Channel 19150 – 10MHz – 16QAM										
1905	85.53	128	2.4	H	11.80	0.32	10.40	21.88	33	-11.12
1905	85.66	160	1.4	V	12.70	0.32	10.40	22.78	33	-10.22
LTE Band 2 Channel 18675 – 15MHz – QPSK										
1857.5	85.71	4	1.8	H	11.74	0.31	10.40	21.83	33	-11.17
1857.5	85.58	147	1.5	V	12.30	0.31	10.40	22.39	33	-10.61
LTE Band 2 Channel 18900 – 15MHz – QPSK										
1880	85.74	85	2.4	H	11.89	0.31	10.40	21.98	33	-11.02
1880	85.93	176	1.6	V	12.81	0.31	10.40	22.90	33	-10.10
LTE Band 2 Channel 19125 – 15MHz – QPSK										
1902.5	86.05	280	1.7	H	12.32	0.32	10.40	22.40	33	-10.60
1902.5	86.11	110	1.5	V	13.15	0.32	10.40	23.23	33	-9.77
LTE Band 2 Channel 18675 – 15MHz – 16QAM										
1857.5	85.70	191	1.3	H	11.73	0.31	10.40	21.82	33	-11.18
1857.5	85.73	98	2.0	V	12.45	0.31	10.40	22.54	33	-10.46

LTE Band 2 Channel 18900 – 15MHz – 16QAM										
1880	85.65	285	2.2	H	11.80	0.31	10.40	21.89	33	-11.11
1880	85.82	31	2.1	V	12.70	0.31	10.40	22.79	33	-10.21
LTE Band 2 Channel 19125 – 15MHz – 16QAM										
1902.5	85.99	134	2.1	H	12.26	0.32	10.40	22.34	33	-10.66
1902.5	85.94	42	2.0	V	12.98	0.32	10.40	23.06	33	-9.94
LTE Band 2 Channel 18700 – 20MHz – QPSK										
1860	85.46	311	1.9	H	11.49	0.31	10.40	21.58	33	-11.42
1860	85.89	312	2.3	V	12.61	0.31	10.40	22.70	33	-10.30
LTE Band 2 Channel 18900 – 20MHz – QPSK										
1880	85.74	236	1.8	H	11.89	0.31	10.40	21.98	33	-11.02
1880	85.53	350	2.3	V	12.41	0.31	10.40	22.50	33	-10.50
LTE Band 2 Channel 19100 – 20MHz – QPSK										
1900	86.58	266	2.3	H	12.85	0.32	10.40	22.93	33	-10.07
1900	86.52	304	2.3	V	13.56	0.32	10.40	<b>23.64</b>	33	-9.36
LTE Band 2 Channel 18670 – 20MHz – 16QAM										
1860	85.61	317	1.8	H	11.64	0.31	10.40	21.73	33	-11.27
1860	85.86	321	1.2	V	12.58	0.31	10.40	22.67	33	-10.33
LTE Band 2 Channel 18900 – 20MHz – 16QAM										
1880	85.66	60	1.4	H	11.81	0.31	10.40	21.90	33	-11.10
1880	85.65	264	2.3	V	12.53	0.31	10.40	22.62	33	-10.38
LTE Band 2 Channel 19100 – 20MHz – 16QAM										
1900	86.68	352	1.5	H	12.95	0.32	10.40	23.03	33	-9.97
1900	86.44	28	1.2	V	13.48	0.32	10.40	<b>23.56</b>	33	-9.44

**LTE Band 4**

Frequency (MHz)	Receiver Reading (dBμV)	Turn table Angle Degree	RX Antenna		Substituted			Absolute Level (dBm)	Part 27	
			Height (m)	Polar (H/V)	SG Level (dBm)	Cable (dB)	Antenna Gain (dB)		Limit (dBm)	Margin (dB)
LTE Band 4 Channel 19957 – 1.4MHz – QPSK										
1710.7	85.98	145	1.1	H	11.87	0.30	9.40	20.97	30	-9.03
1710.7	85.62	198	2.2	V	12.09	0.30	9.40	21.19	30	-8.81
LTE Band 4 Channel 20175 – 1.4MHz – QPSK										
1732.5	86.17	28	1.1	H	12.06	0.30	9.40	21.16	30	-8.84
1732.5	85.94	14	1.6	V	12.41	0.30	9.40	21.51	30	-8.49
LTE Band 4 Channel 20393 – 1.4MHz – QPSK										
1754.3	86.05	252	2.0	H	11.94	0.30	9.40	21.04	30	-8.96
1754.3	86.23	1	1.5	V	12.70	0.30	9.40	21.80	30	-8.20
LTE Band 4 Channel 19957 – 1.4MHz – 16QAM										
1710.7	85.96	299	1.3	H	11.85	0.30	9.40	20.95	30	-9.05
1710.7	85.77	72	2.0	V	12.24	0.30	9.40	21.34	30	-8.66
LTE Band 4 Channel 20175 – 1.4MHz – 16QAM										
1732.5	86.07	153	2.5	H	11.96	0.30	9.40	21.06	30	-8.94
1732.5	86.03	56	1.3	V	12.50	0.30	9.40	21.60	30	-8.40
LTE Band 4 Channel 20393 – 1.4MHz – 16QAM										
1754.3	86.03	64	1.7	H	11.92	0.30	9.40	21.02	30	-8.98
1754.3	85.96	155	2.1	V	12.43	0.30	9.40	21.53	30	-8.47
LTE Band 4 Channel 19965 – 3MHz – QPSK										
1711.5	85.75	330	1.5	H	11.64	0.30	9.40	20.74	30	-9.26
1711.5	86.24	234	1.5	V	12.71	0.30	9.40	21.81	30	-8.19
LTE Band 4 Channel 20175 – 3MHz – QPSK										
1732.5	86.05	222	1.4	H	11.94	0.30	9.40	21.04	30	-8.96
1732.5	85.97	334	2.3	V	12.44	0.30	9.40	21.54	30	-8.46
LTE Band 4 Channel 20385 – 3MHz – QPSK										
1753.5	85.93	101	1.2	H	11.82	0.30	9.40	20.92	30	-9.08
1753.5	85.70	233	2.2	V	12.17	0.30	9.40	21.27	30	-8.73
LTE Band 4 Channel 19965 – 3MHz – 16QAM										
1711.5	86.04	220	2.3	H	11.93	0.30	9.40	21.03	30	-8.97
1711.5	85.82	36	1.9	V	12.29	0.30	9.40	21.39	30	-8.61
LTE Band 4 Channel 20175 – 3MHz – 16QAM										
1732.5	85.98	266	2.0	H	11.87	0.30	9.40	20.97	30	-9.03
1732.5	86.29	7	1.6	V	12.76	0.30	9.40	21.86	30	-8.14
LTE Band 4 Channel 20385 – 3MHz – 16QAM										
1753.5	85.69	13	2.1	H	11.58	0.30	9.40	20.68	30	-9.32
1753.5	86.20	336	1.4	V	12.67	0.30	9.40	21.77	30	-8.23
LTE Band 4 Channel 19975 – 5MHz – QPSK										
1712.5	86.10	54	1.2	H	11.99	0.30	9.40	21.09	30	-8.91
1712.5	85.79	135	2.5	V	12.26	0.30	9.40	21.36	30	-8.64
LTE Band 4 Channel 20175 – 5MHz – QPSK										
1732.5	86.24	167	1.1	H	12.13	0.30	9.40	21.23	30	-8.77
1732.5	86.02	32	2.5	V	12.49	0.30	9.40	21.59	30	-8.41

LTE Band 4 Channel 20375 – 5MHz – QPSK										
1752.5	85.90	47	2.5	H	11.79	0.30	9.40	20.89	30	-9.11
1752.5	85.89	106	2.5	V	12.36	0.30	9.40	21.46	30	-8.54
LTE Band 4 Channel 19975 – 5MHz – 16QAM										
1712.5	85.99	212	1.3	H	11.88	0.30	9.40	20.98	30	-9.02
1712.5	86.11	106	2.3	V	12.58	0.30	9.40	21.68	30	-8.32
LTE Band 4 Channel 20175 – 5MHz – 16QAM										
1732.5	85.82	26	1.5	H	11.71	0.30	9.40	20.81	30	-9.19
1732.5	86.32	46	2.2	V	12.79	0.30	9.40	21.89	30	-8.11
LTE Band 4 Channel 20375 – 5MHz – 16QAM										
1752.5	86.28	209	1.0	H	12.17	0.30	9.40	21.27	30	-8.73
1752.5	86.00	182	1.9	V	12.47	0.30	9.40	21.57	30	-8.43
LTE Band 4 Channel 20000 – 10MHz – QPSK										
1715	86.45	118	1.2	H	12.34	0.30	9.40	21.44	30	-8.56
1715	86.25	289	2.4	V	12.72	0.30	9.40	21.82	30	-8.18
LTE Band 4 Channel 20175 – 10MHz – QPSK										
1732.5	85.64	74	2.2	H	11.53	0.30	9.40	20.63	30	-9.37
1732.5	85.84	169	1.2	V	12.31	0.30	9.40	21.41	30	-8.59
LTE Band 4 Channel 20350 – 10MHz – QPSK										
1750	86.32	352	1.4	H	12.21	0.30	9.40	21.31	30	-8.69
1750	85.81	211	2.0	V	12.28	0.30	9.40	21.38	30	-8.62
LTE Band 4 Channel 20000 – 10MHz – 16QAM										
1715	86.28	122	2.1	H	12.17	0.30	9.40	21.27	30	-8.73
1715	86.24	354	2.0	V	12.71	0.30	9.40	21.81	30	-8.19
LTE Band 4 Channel 20175 – 10MHz – 16QAM										
1732.5	85.82	275	1.1	H	11.71	0.30	9.40	20.81	30	-9.19
1732.5	86.40	72	1.1	V	12.87	0.30	9.40	21.97	30	-8.03
LTE Band 4 Channel 20350 – 10MHz – 16QAM										
1750	85.85	86	1.1	H	11.74	0.30	9.40	20.84	30	-9.16
1750	86.09	197	2.4	V	12.56	0.30	9.40	21.66	30	-8.34
LTE Band 4 Channel 20025 – 15MHz – QPSK										
1717.5	85.56	243	2.2	H	11.45	0.30	9.40	20.55	30	-9.45
1717.5	86.02	219	1.9	V	12.49	0.30	9.40	21.59	30	-8.41
LTE Band 4 Channel 20175 – 15MHz – QPSK										
1732.5	85.75	103	2.3	H	11.64	0.30	9.40	20.74	30	-9.26
1732.5	85.81	13	1.6	V	12.28	0.30	9.40	21.38	30	-8.62
LTE Band 4 Channel 20325 – 15MHz – QPSK										
1747.5	85.85	26	1.8	H	11.74	0.30	9.40	20.84	30	-9.16
1747.5	86.04	122	1.4	V	12.51	0.30	9.40	21.61	30	-8.39
LTE Band 4 Channel 20025 – 15MHz – 16QAM										
1717.5	86.10	290	1.0	H	11.99	0.30	9.40	21.09	30	-8.91
1717.5	85.86	268	1.1	V	12.33	0.30	9.40	21.43	30	-8.57
LTE Band 4 Channel 20175 – 15MHz – 16QAM										
1732.5	86.00	175	1.9	H	11.89	0.30	9.40	20.99	30	-9.01
1732.5	85.59	26	1.4	V	12.06	0.30	9.40	21.16	30	-8.84

LTE Band 4 Channel 20325 – 15MHz – 16QAM										
1747.5	85.89	211	2.1	H	11.78	0.30	9.40	20.88	30	-9.12
1747.5	85.94	165	1.9	V	12.41	0.30	9.40	21.51	30	-8.49
LTE Band 4 Channel 20050 – 20MHz – QPSK										
1720	87.12	82	1.4	H	13.01	0.30	9.40	22.11	30	-7.89
1720	87.52	145	1.7	V	13.99	0.30	9.40	<b>23.09</b>	30	-6.91
LTE Band 4 Channel 20175 – 20MHz – QPSK										
1732.5	86.16	87	2.4	H	12.05	0.30	9.40	21.15	30	-8.85
1732.5	85.70	87	2.4	V	12.17	0.30	9.40	21.27	30	-8.73
LTE Band 4 Channel 20300 – 20MHz – QPSK										
1745	86.20	305	1.1	H	12.09	0.30	9.40	21.19	30	-8.81
1745	85.89	71	1.9	V	12.36	0.30	9.40	21.46	30	-8.54
LTE Band 4 Channel 20050 – 20MHz – 16QAM										
1720	87.44	349	1.2	H	13.33	0.30	9.40	22.43	30	-7.57
1720	87.56	59	2.1	V	14.03	0.30	9.40	<b>23.13</b>	30	-6.87
LTE Band 4 Channel 20175 – 20MHz – 16QAM										
1732.5	86.37	251	2.0	H	12.26	0.30	9.40	21.36	30	-8.64
1732.5	85.74	50	1.4	V	12.21	0.30	9.40	21.31	30	-8.69
LTE Band 4 Channel 20300 – 20MHz – 16QAM										
1745	85.79	52	1.3	H	11.68	0.30	9.40	20.78	30	-9.22
1745	85.75	236	2.3	V	12.22	0.30	9.40	21.32	30	-8.68

**LTE Band 5**

Frequency (MHz)	Receiver Reading (dBμV)	Turn table Angle Degree	RX Antenna		Substituted			Absolute Level (dBm)	Part 22H	
			Height (m)	Polar (H/V)	SG Level (dBm)	Cable (dB)	Antenna Gain (dB)		Limit (dBm)	Margin (dB)
LTE Band 5 Channel 20407 – 1.4MHz – QPSK										
824.7	80.77	247	1.3	H	13.66	0.30	9.40	22.76	38.45	-15.69
824.7	80.83	204	1.7	V	13.30	0.30	9.40	22.40	38.45	-16.05
LTE Band 5 Channel 20525 – 1.4MHz – QPSK										
836.5	80.64	7	2.2	H	13.53	0.30	9.40	22.63	38.45	-15.82
836.5	80.68	190	2.3	V	13.15	0.30	9.40	22.25	38.45	-16.20
LTE Band 5 Channel 20643 – 1.4MHz – QPSK										
848.3	80.56	0	1.1	H	13.45	0.30	9.40	22.55	38.45	-15.90
848.3	80.86	250	1.1	V	13.33	0.30	9.40	22.43	38.45	-16.02
LTE Band 5 Channel 20407 – 1.4MHz – 16QAM										
824.7	80.96	257	1.2	H	13.85	0.30	9.40	22.95	38.45	-15.50
824.7	80.66	206	2.4	V	13.13	0.30	9.40	22.23	38.45	-16.22
LTE Band 5 Channel 20525 – 1.4MHz – 16QAM										
836.5	80.71	54	2.1	H	13.60	0.30	9.40	22.70	38.45	-15.75
836.5	80.98	50	2.3	V	13.45	0.30	9.40	22.55	38.45	-15.90
LTE Band 5 Channel 20643 – 1.4MHz – 16QAM										
848.3	80.64	251	2.2	H	13.53	0.30	9.40	22.63	38.45	-15.82
848.3	80.88	21	2.2	V	13.35	0.30	9.40	22.45	38.45	-16.00
LTE Band 5 Channel 20415 – 3MHz – QPSK										
825.5	80.96	260	1.2	H	13.85	0.30	9.40	22.95	38.45	-15.50
825.5	80.90	127	1.5	V	13.37	0.30	9.40	22.47	38.45	-15.98
LTE Band 5 Channel 20525 – 3MHz – QPSK										
836.5	80.81	48	1.2	H	13.70	0.30	9.40	22.80	38.45	-15.65
836.5	81.06	287	2.4	V	13.53	0.30	9.40	22.63	38.45	-15.82
LTE Band 5 Channel 20635 – 3MHz – QPSK										
847.5	80.74	274	2.5	H	13.63	0.30	9.40	22.73	38.45	-15.72
847.5	80.52	169	2.0	V	12.99	0.30	9.40	22.09	38.45	-16.36
LTE Band 5 Channel 20415 – 3MHz – 16QAM										
825.5	80.94	239	1.3	H	13.83	0.30	9.40	22.93	38.45	-15.52
825.5	81.05	288	2.3	V	13.52	0.30	9.40	22.62	38.45	-15.83
LTE Band 5 Channel 20525 – 3MHz – 16QAM										
836.5	81.00	239	1.4	H	13.89	0.30	9.40	22.99	38.45	-15.46
836.5	81.00	217	2.1	V	13.47	0.30	9.40	22.57	38.45	-15.88
LTE Band 5 Channel 20635 – 3MHz – 16QAM										
847.5	80.68	178	2.1	H	13.57	0.30	9.40	22.67	38.45	-15.78
847.5	80.93	62	2.4	V	13.40	0.30	9.40	22.50	38.45	-15.95
LTE Band 5 Channel 20425 – 5MHz – QPSK										
826.5	80.87	286	1.4	H	13.76	0.30	9.40	22.86	38.45	-15.59
826.5	81.14	13	1.8	V	13.61	0.30	9.40	22.71	38.45	-15.74
LTE Band 5 Channel 20525 – 5MHz – QPSK										
836.5	80.41	150	1.0	H	13.30	0.30	9.40	22.40	38.45	-16.05
836.5	81.09	255	2.2	V	13.56	0.30	9.40	22.66	38.45	-15.79

LTE Band 5 Channel 20625 – 5MHz – QPSK										
846.5	80.39	329	1.7	H	13.28	0.30	9.40	22.38	38.45	-16.07
846.5	80.93	194	1.4	V	13.40	0.30	9.40	22.50	38.45	-15.95
LTE Band 5 Channel 20425 – 5MHz – 16QAM										
826.5	81.22	31	1.3	H	14.11	0.30	9.40	23.21	38.45	-15.24
826.5	80.75	176	1.1	V	13.22	0.30	9.40	22.32	38.45	-16.13
LTE Band 5 Channel 20525 – 5MHz – 16QAM										
836.5	80.86	329	2.5	H	13.75	0.30	9.40	22.85	38.45	-15.60
836.5	80.92	270	1.2	V	13.39	0.30	9.40	22.49	38.45	-15.96
LTE Band 5 Channel 20625 – 5MHz – 16QAM										
846.5	80.65	158	1.7	H	13.54	0.30	9.40	22.64	38.45	-15.81
846.5	80.89	114	1.1	V	13.36	0.30	9.40	22.46	38.45	-15.99
LTE Band 5 Channel 20450 – 10MHz – QPSK										
829	81.39	295	1.3	H	14.28	0.30	9.40	<b>23.38</b>	38.45	-15.07
829	81.33	31	1.5	V	13.80	0.30	9.40	22.90	38.45	-15.55
LTE Band 5 Channel 20525 – 10MHz – QPSK										
836.5	80.60	253	1.7	H	13.49	0.30	9.40	22.59	38.45	-15.86
836.5	80.75	115	2.2	V	13.22	0.30	9.40	22.32	38.45	-16.13
LTE Band 5 Channel 20600 – 10MHz – QPSK										
844	80.62	162	1.5	H	13.51	0.30	9.40	22.61	38.45	-15.84
844	81.14	105	2.1	V	13.61	0.30	9.40	22.71	38.45	-15.74
LTE Band 5 Channel 20450 – 10MHz – 16QAM										
829	81.33	121	2.1	H	14.22	0.30	9.40	<b>23.32</b>	38.45	-15.13
829	81.29	303	1.7	V	13.76	0.30	9.40	22.86	38.45	-15.59
LTE Band 5 Channel 20525 – 10MHz – 16QAM										
836.5	80.76	91	2.4	H	13.65	0.30	9.40	22.75	38.45	-15.70
836.5	80.77	112	1.8	V	13.24	0.30	9.40	22.34	38.45	-16.11
LTE Band 5 Channel 20600 – 10MHz – 16QAM										
844	80.62	180	1.5	H	13.51	0.30	9.40	22.61	38.45	-15.84
844	80.67	359	2.1	V	13.14	0.30	9.40	22.24	38.45	-16.21



**LTE Band 12**

Frequency (MHz)	Receiver Reading (dBμV)	Turn table Angle Degree	RX Antenna		Substituted			Absolute Level (dBm)	Part 27	
			Height (m)	Polar (H/V)	SG Level (dBm)	Cable (dB)	Antenna Gain (dB)		Limit (dBm)	Margin (dB)
LTE Band 12 Channel 23017 – 1.4MHz – QPSK										
699.7	94.11	205	2.3	H	23.11	0.20	0.00	22.91	34.77	-11.86
699.7	94.03	245	2.2	V	21.75	0.20	0.00	21.55	34.77	-13.22
LTE Band 12 Channel 23095 – 1.4MHz – QPSK										
707.5	94.29	219	1.3	H	23.29	0.20	0.00	23.09	34.77	-11.68
707.5	94.15	53	1.1	V	21.87	0.20	0.00	21.67	34.77	-13.10
LTE Band 12 Channel 23173 – 1.4MHz – QPSK										
715.3	93.80	93	2.3	H	22.80	0.20	0.00	22.60	34.77	-12.17
715.3	94.06	337	2.4	V	21.78	0.20	0.00	21.58	34.77	-13.19
LTE Band 12 Channel 23017 – 1.4MHz – 16QAM										
699.7	94.58	152	2.0	H	23.58	0.20	0.00	23.38	34.77	-11.39
699.7	93.71	60	1.6	V	21.43	0.20	0.00	21.23	34.77	-13.54
LTE Band 12 Channel 23095 – 1.4MHz – 16QAM										
707.5	94.32	291	1.7	H	23.32	0.20	0.00	23.12	34.77	-11.65
707.5	94.29	201	2.0	V	22.01	0.20	0.00	21.81	34.77	-12.96
LTE Band 12 Channel 23173 – 1.4MHz – 16QAM										
715.3	94.22	107	1.5	H	23.22	0.20	0.00	23.02	34.77	-11.75
715.3	94.37	277	1.7	V	22.09	0.20	0.00	21.89	34.77	-12.88
LTE Band 12 Channel 23025 – 3MHz – QPSK										
700.5	94.31	229	1.6	H	23.31	0.20	0.00	23.11	34.77	-11.66
700.5	94.22	329	1.7	V	21.94	0.20	0.00	21.74	34.77	-13.03
LTE Band 12 Channel 23095 – 3MHz – QPSK										
707.5	93.91	139	1.1	H	22.91	0.20	0.00	22.71	34.77	-12.06
707.5	93.71	27	1.3	V	21.43	0.20	0.00	21.23	34.77	-13.54
LTE Band 12 Channel 23165 – 3MHz – QPSK										
714.5	94.38	19	2.3	H	23.38	0.20	0.00	23.18	34.77	-11.59
714.5	94.46	226	1.8	V	22.18	0.20	0.00	21.98	34.77	-12.79
LTE Band 12 Channel 23025 – 3MHz – 16QAM										
700.5	94.08	21	1.5	H	23.08	0.20	0.00	22.88	34.77	-11.89
700.5	93.90	212	2.3	V	21.62	0.20	0.00	21.42	34.77	-13.35
LTE Band 12 Channel 23095 – 3MHz – 16QAM										
707.5	93.68	264	1.6	H	22.68	0.20	0.00	22.48	34.77	-12.29
707.5	94.51	302	1.0	V	22.23	0.20	0.00	22.03	34.77	-12.74
LTE Band 12 Channel 23165 – 3MHz – 16QAM										
714.5	94.08	282	2.0	H	23.08	0.20	0.00	22.88	34.77	-11.89
714.5	94.12	318	2.2	V	21.84	0.20	0.00	21.64	34.77	-13.13
LTE Band 12 Channel 23035 – 5MHz – QPSK										
701.5	94.22	57	2.0	H	23.22	0.20	0.00	23.02	34.77	-11.75
701.5	94.00	290	1.7	V	21.72	0.20	0.00	21.52	34.77	-13.25
LTE Band 12 Channel 23095 – 5MHz – QPSK										
707.5	94.04	165	1.1	H	23.04	0.20	0.00	22.84	34.77	-11.93
707.5	94.10	234	1.9	V	21.82	0.20	0.00	21.62	34.77	-13.15

LTE Band 12 Channel 23155 – 5MHz – QPSK										
713.5	93.86	190	1.8	H	22.86	0.20	0.00	22.66	34.77	-12.11
713.5	93.69	308	1.3	V	21.41	0.20	0.00	21.21	34.77	-13.56
LTE Band 12 Channel 23035 – 5MHz – 16QAM										
701.5	93.92	299	1.1	H	22.92	0.20	0.00	22.72	34.77	-12.05
701.5	94.07	232	1.3	V	21.79	0.20	0.00	21.59	34.77	-13.18
LTE Band 12 Channel 23095 – 5MHz – 16QAM										
707.5	94.09	126	1.7	H	23.09	0.20	0.00	22.89	34.77	-11.88
707.5	93.74	47	1.7	V	21.46	0.20	0.00	21.26	34.77	-13.51
LTE Band 12 Channel 23155 – 5MHz – 16QAM										
713.5	94.22	275	2.4	H	23.22	0.20	0.00	23.02	34.77	-11.75
713.5	94.05	72	2.2	V	21.77	0.20	0.00	21.57	34.77	-13.20
LTE Band 12 Channel 23060 – 10MHz – QPSK										
704	93.93	92	1.3	H	22.93	0.20	0.00	22.73	34.77	-12.04
704	94.16	89	1.6	V	21.88	0.20	0.00	21.68	34.77	-13.09
LTE Band 12 Channel 23095 – 10MHz – QPSK										
707.5	94.76	187	2.1	H	23.76	0.20	0.00	<b>23.56</b>	34.77	-11.21
707.5	94.78	27	1.2	V	22.50	0.20	0.00	22.30	34.77	-12.47
LTE Band 12 Channel 23130 – 10MHz – QPSK										
711	93.91	214	1.6	H	22.91	0.20	0.00	22.71	34.77	-12.06
711	93.78	118	2.3	V	21.50	0.20	0.00	21.30	34.77	-13.47
LTE Band 12 Channel 23060 – 10MHz – 16QAM										
704	94.00	324	2.0	H	23.00	0.20	0.00	22.80	34.77	-11.97
704	93.82	131	1.8	V	21.54	0.20	0.00	21.34	34.77	-13.43
LTE Band 12 Channel 23095 – 10MHz – 16QAM										
707.5	94.65	14	1.0	H	23.65	0.20	0.00	<b>23.45</b>	34.77	-11.32
707.5	94.79	108	1.9	V	22.51	0.20	0.00	22.31	34.77	-12.46
LTE Band 12 Channel 23130 – 10MHz – 16QAM										
711	94.33	321	1.2	H	23.33	0.20	0.00	23.13	34.77	-11.64
711	94.13	247	1.4	V	21.85	0.20	0.00	21.65	34.77	-13.12

## LTE Band 13

Frequency (MHz)	Receiver Reading (dBμV)	Turn table Angle Degree	RX Antenna		Substituted			Absolute Level (dBm)	Part 27	
			Height (m)	Polar (H/V)	SG Level (dBm)	Cable (dB)	Antenna Gain (dB)		Limit (dBm)	Margin (dB)
LTE Band 13 Channel 23205 – 5MHz – QPSK										
779.5	93.42	53	2.3	H	22.42	0.20	0.00	22.22	34.77	-12.55
779.5	93.13	113	1.7	V	20.85	0.20	0.00	20.65	34.77	-14.12
LTE Band 13 Channel 23230 – 5MHz – QPSK										
782	93.49	270	1.4	H	22.49	0.20	0.00	22.29	34.77	-12.48
782	93.53	291	2.0	V	21.25	0.20	0.00	21.05	34.77	-13.72
LTE Band 13 Channel 23255 – 5MHz – QPSK										
784.5	93.42	68	1.3	H	22.42	0.20	0.00	22.22	34.77	-12.55
784.5	93.15	7	1.2	V	20.87	0.20	0.00	20.67	34.77	-14.10
LTE Band 13 Channel 23205 – 5MHz – 16QAM										
779.5	93.39	115	1.0	H	22.39	0.20	0.00	22.19	34.77	-12.58
779.5	93.15	12	1.8	V	20.87	0.20	0.00	20.67	34.77	-14.10
LTE Band 13 Channel 23230 – 5MHz – 16QAM										
782	93.83	176	1.3	H	22.83	0.20	0.00	22.63	34.77	-12.14
782	93.45	247	1.8	V	21.17	0.20	0.00	20.97	34.77	-13.80
LTE Band 13 Channel 23255 – 5MHz – 16QAM										
784.5	93.23	167	1.0	H	22.23	0.20	0.00	22.03	34.77	-12.74
784.5	93.12	77	1.3	V	20.84	0.20	0.00	20.64	34.77	-14.13
LTE Band 13 Channel 23230 – 10MHz – QPSK										
782	94.25	254	2.4	H	23.25	0.20	0.00	<b>23.05</b>	34.77	-11.72
782	94.17	193	2.3	V	21.89	0.20	0.00	21.69	34.77	-13.08
LTE Band 13 Channel 23230 – 10MHz – 16QAM										
782	94.31	212	2.2	H	23.31	0.20	0.00	<b>23.11</b>	34.77	-11.66
782	94.25	43	1.5	V	21.97	0.20	0.00	21.77	34.77	-13.00

**LTE Band 66**

Frequency	Receiver Reading	Turn table Angle	RX Antenna		Substituted			Absolute Level	Part 27	
			Height	Polar	SG Level	Cable	Antenna Gain		Limit	Margin
(MHz)	(dBμV)	Degree	(m)	(H/V)	(dBm)	(dB)	(dB)	(dBm)	(dBm)	(dB)
LTE Band 66 Channel 131979 – 1.4MHz – QPSK										
1710.7	87.14	317	2.0	H	13.14	0.30	9.40	22.24	30	-7.76
1710.7	87.21	130	1.6	V	11.93	0.30	9.40	21.03	30	-8.97
LTE Band 66 Channel 132321 – 1.4MHz – QPSK										
1744.9	87.19	198	1.7	H	13.19	0.30	9.40	22.29	30	-7.71
1744.9	87.43	242	1.8	V	12.15	0.30	9.40	21.25	30	-8.75
LTE Band 66 Channel 132664 – 1.4MHz – QPSK										
1779.2	87.13	87	1.6	H	13.02	0.30	9.40	22.12	30	-7.88
1779.2	87.48	74	1.4	V	12.29	0.30	9.40	21.39	30	-8.61
LTE Band 66 Channel 131979 – 1.4MHz – 16QAM										
1710.7	87.18	86	1.9	H	13.18	0.30	9.40	22.28	30	-7.72
1710.7	87.33	300	1.7	V	12.05	0.30	9.40	21.15	30	-8.85
LTE Band 66 Channel 132321 – 1.4MHz – 16QAM										
1744.9	87.22	257	2.1	H	13.22	0.30	9.40	22.32	30	-7.68
1744.9	87.49	143	1.1	V	12.21	0.30	9.40	21.31	30	-8.69
LTE Band 66 Channel 132664 – 1.4MHz – 16QAM										
1779.2	86.84	91	1.6	H	12.73	0.30	9.40	21.83	30	-8.17
1779.2	87.00	232	1.8	V	11.81	0.30	9.40	20.91	30	-9.09
LTE Band 66 Channel 131987 – 3MHz – QPSK										
1711.5	87.47	202	2.4	H	13.47	0.30	9.40	22.57	30	-7.43
1711.5	87.30	115	1.6	V	12.02	0.30	9.40	21.12	30	-8.88
LTE Band 66 Channel 132321 – 3MHz – QPSK										
1744.9	87.16	309	1.4	H	13.16	0.30	9.40	22.26	30	-7.74
1744.9	86.83	229	1.9	V	11.55	0.30	9.40	20.65	30	-9.35
LTE Band 66 Channel 132665 – 3MHz – QPSK										
1778.4	87.16	201	1.2	H	13.05	0.30	9.40	22.15	30	-7.85
1778.4	86.93	117	2.4	V	11.74	0.30	9.40	20.84	30	-9.16
LTE Band 66 Channel 131987 – 3MHz – 16QAM										
1711.5	87.21	285	1.0	H	13.21	0.30	9.40	22.31	30	-7.69
1711.5	87.39	251	1.2	V	12.11	0.30	9.40	21.21	30	-8.79
LTE Band 66 Channel 132321 – 3MHz – 16QAM										
1744.9	87.03	271	1.4	H	13.03	0.30	9.40	22.13	30	-7.87
1744.9	87.00	355	1.9	V	11.72	0.30	9.40	20.82	30	-9.18
LTE Band 66 Channel 132665 – 3MHz – 16QAM										
1778.4	87.11	234	1.1	H	13.00	0.30	9.40	22.10	30	-7.90
1778.4	86.70	248	1.7	V	11.51	0.30	9.40	20.61	30	-9.39
LTE Band 66 Channel 131997 – 5MHz – QPSK										
1712.5	87.14	263	2.3	H	13.14	0.30	9.40	22.24	30	-7.76
1712.5	86.92	157	2.3	V	11.64	0.30	9.40	20.74	30	-9.26
LTE Band 66 Channel 132321 – 5MHz – QPSK										
1744.9	87.15	324	1.6	H	13.15	0.30	9.40	22.25	30	-7.75
1744.9	86.95	198	1.8	V	11.67	0.30	9.40	20.77	30	-9.23

LTE Band 66 Channel 132646 – 5MHz – QPSK										
1777.4	87.14	256	2.1	H	13.03	0.30	9.40	22.13	30	-7.87
1777.4	87.37	132	1.6	V	12.18	0.30	9.40	21.28	30	-8.72
LTE Band 66 Channel 131997 – 5MHz – 16QAM										
1712.5	86.86	65	1.7	H	12.86	0.30	9.40	21.96	30	-8.04
1712.5	87.13	182	2.2	V	11.85	0.30	9.40	20.95	30	-9.05
LTE Band 66 Channel 132321 – 5MHz – 16QAM										
1744.9	86.90	19	1.4	H	12.90	0.30	9.40	22.00	30	-8.00
1744.9	87.16	43	1.6	V	11.88	0.30	9.40	20.98	30	-9.02
LTE Band 66 Channel 131997 – 5MHz – 16QAM										
1777.4	86.89	282	2.2	H	12.78	0.30	9.40	21.88	30	-8.12
1777.4	86.92	356	1.9	V	11.73	0.30	9.40	20.83	30	-9.17
LTE Band 66 Channel 132022 – 10MHz – QPSK										
1715	86.99	53	1.1	H	12.99	0.30	9.40	22.09	30	-7.91
1715	87.35	294	2.4	V	12.07	0.30	9.40	21.17	30	-8.83
LTE Band 66 Channel 132321 – 10MHz – QPSK										
1744.9	87.50	189	1.1	H	13.50	0.30	9.40	22.60	30	-7.40
1744.9	86.71	145	2.2	V	11.43	0.30	9.40	20.53	30	-9.47
LTE Band 66 Channel 132621 – 10MHz – QPSK										
1774.9	87.21	142	1.6	H	13.10	0.30	9.40	22.20	30	-7.80
1774.9	87.23	310	1.6	V	12.04	0.30	9.40	21.14	30	-8.86
LTE Band 66 Channel 132022 – 10MHz – 16QAM										
1715	87.16	176	1.4	H	13.16	0.30	9.40	22.26	30	-7.74
1715	87.35	104	2.5	V	12.07	0.30	9.40	21.17	30	-8.83
LTE Band 66 Channel 132321 – 10MHz – 16QAM										
1744.9	87.27	67	2.2	H	13.27	0.30	9.40	22.37	30	-7.63
1744.9	87.14	219	1.9	V	11.86	0.30	9.40	20.96	30	-9.04
LTE Band 66 Channel 132621 – 10MHz – 16QAM										
1774.9	87.44	46	2.4	H	13.33	0.30	9.40	22.43	30	-7.57
1774.9	87.22	323	1.8	V	12.03	0.30	9.40	21.13	30	-8.87
LTE Band 66 Channel 132097 – 15MHz – QPSK										
1722.5	86.77	8	1.3	H	12.77	0.30	9.40	21.87	30	-8.13
1722.5	87.08	327	1.5	V	11.80	0.30	9.40	20.90	30	-9.10
LTE Band 66 Channel 132321 – 15MHz – QPSK										
1744.9	87.17	147	1.2	H	13.17	0.30	9.40	22.27	30	-7.73
1744.9	87.35	173	1.8	V	12.07	0.30	9.40	21.17	30	-8.83
LTE Band 66 Channel 132546 – 15MHz – QPSK										
1767.4	87.06	11	2.0	H	12.95	0.30	9.40	22.05	30	-7.95
1767.4	87.32	75	2.2	V	12.13	0.30	9.40	21.23	30	-8.77
LTE Band 66 Channel 132097 – 15MHz – 16QAM										
1722.5	86.93	226	1.3	H	12.93	0.30	9.40	22.03	30	-7.97
1722.5	87.15	256	1.9	V	11.87	0.30	9.40	20.97	30	-9.03
LTE Band 66 Channel 132321 – 15MHz – 16QAM										
1744.9	87.17	126	1.7	H	13.17	0.30	9.40	22.27	30	-7.73
1744.9	87.33	164	1.7	V	12.05	0.30	9.40	21.15	30	-8.85
LTE Band 66 Channel 132546 – 15MHz – 16QAM										
1767.4	87.42	273	1.5	H	13.42	0.30	9.40	22.52	30	-7.48
1767.4	86.81	237	2.0	V	11.53	0.30	9.40	20.63	30	-9.37

LTE Band 66 Channel 132072 – 20MHz – QPSK										
1720	87.21	54	1.9	H	13.21	0.30	9.40	22.31	30	-7.69
1720	87.06	334	1.8	V	11.78	0.30	9.40	20.88	30	-9.12
LTE Band 66 Channel 132321 – 20MHz – QPSK										
1744.9	88.08	188	1.5	H	14.08	0.30	9.40	<b>23.18</b>	30	-6.82
1744.9	88.43	296	1.3	V	13.15	0.30	9.40	22.25	30	-7.75
LTE Band 66 Channel 132471 – 20MHz – QPSK										
1759.9	87.19	167	2.5	H	13.08	0.30	9.40	22.18	30	-7.82
1759.9	86.83	143	1.9	V	11.64	0.30	9.40	20.74	30	-9.26
LTE Band 66 Channel 132072 – 20MHz – 16QAM										
1720	86.85	60	2.3	H	12.85	0.30	9.40	21.95	30	-8.05
1720	87.57	342	1.1	V	12.29	0.30	9.40	21.39	30	-8.61
LTE Band 66 Channel 132321 – 20MHz – 16QAM										
1744.9	87.96	301	2.4	H	13.96	0.30	9.40	<b>23.06</b>	30	-6.94
1744.9	88.10	275	1.7	V	12.82	0.30	9.40	21.92	30	-8.08
LTE Band 66 Channel 132471 – 20MHz – 16QAM										
1759.9	87.04	114	1.1	H	12.93	0.30	9.40	22.03	30	-7.97
1759.9	87.24	274	1.4	V	12.05	0.30	9.40	21.15	30	-8.85

## 8 Peak-to-Average Ratio

Test Requirement:	24.232 (d), 27.50(d)
Test Method:	N/A
Test Mode:	TX transmitting

### 8.1 EUT Operation

Operating Environment :

Temperature:	23.9 °C
Humidity:	54.6 % RH
Atmospheric Pressure:	101.3kPa

### 8.2 Test Procedure

1. The EUT was connected to spectrum analyzer and system simulator via a power divider.
2. Set EUT to transmit at maximum output power.
3. When the duty cycle is less than 98%, then signal gating will be implemented on the spectrum analyzer by triggering from the system simulator.
4. Set the CCDF (Complementary Cumulative Distribution Function) option of the spectrum analyzer. Record the maximum PAPR level associated with a probability of 0.1%.

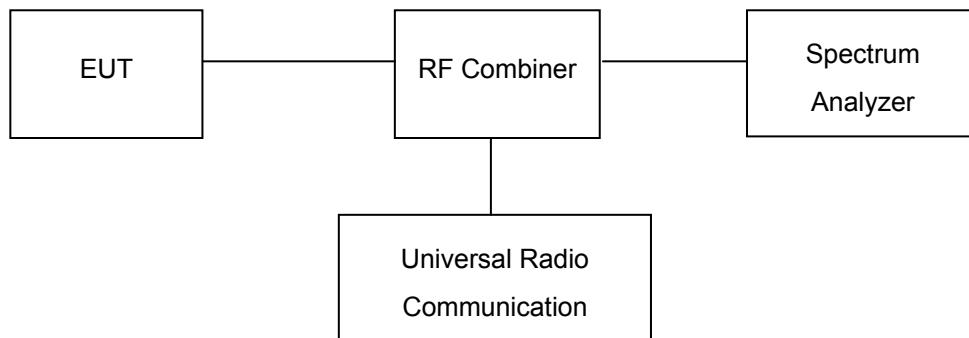

### 8.3 Test Result

PASS

#### LTE Band

Please refer to the Appendix Band 2/4/5/12/13/66 LTE Peak to Average Ratio.

## 9 Bandwidth

Test Requirement:	FCC Part 2.1049, 22.917, 22.905, 24.238, 27.53(a); 90.691
Test Method:	ANSI C63.26:2015 ANSI/TIA-603-E:2016
Test Mode:	TX transmitting

### 9.1 EUT Operation

Operating Environment :

Temperature:	23.9 °C
Humidity:	54.6 % RH
Atmospheric Pressure:	101.3kPa

### 9.2 Test Procedure

The RF output of the transmitter was connected to the wireless test set and the spectrum analyzer through sufficient attenuation.

The resolution bandwidth of the spectrum analyzer was set in the range of 1 to 5 % of the anticipated OBW and the 26 dB & 99%bandwidth was recorded.

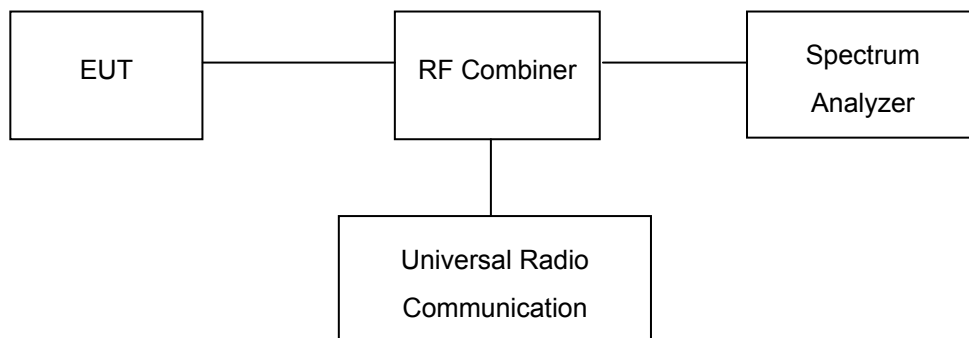



### 9.3 Test Result

#### LTE Band 2 (Part 24E):

BW(MHz)	Channel	Frequency (MHz)	Modulation	99% Occupied Bandwidth (MHz)	26 dB Bandwidth (MHz)
1.4	18607	1850.7	QPSK	1.09	1.25
			16QAM	1.09	1.26
1.4	18900	1880	QPSK	1.09	1.25
			16QAM	1.09	1.26
1.4	19193	1909.3	QPSK	1.09	1.25
			16QAM	1.09	1.25
3	18615	1851.5	QPSK	2.68	2.86
			16QAM	2.68	2.86
3	18900	1880	QPSK	2.68	2.86
			16QAM	2.68	2.87
3	19185	1908.5	QPSK	2.68	2.87
			16QAM	2.68	2.87
5	18625	1852.5	QPSK	4.49	4.79
			16QAM	4.49	4.77
5	18900	1880	QPSK	4.49	4.78
			16QAM	4.48	4.79
5	19175	1907.5	QPSK	4.48	4.77
			16QAM	4.49	4.79
10	18650	1855	QPSK	8.92	9.34
			16QAM	8.91	9.33
10	18900	1880	QPSK	8.91	9.34
			16QAM	8.91	9.32
10	19150	1905	QPSK	8.92	9.35
			16QAM	8.92	9.34
15	18675	1857.5	QPSK	13.44	14.22
			16QAM	13.44	14.22
15	18900	1880	QPSK	13.45	14.21
			16QAM	13.44	14.22
15	19125	1902.5	QPSK	13.46	14.23
			16QAM	13.46	14.22
20	18700	1860	QPSK	17.86	18.73
			16QAM	17.86	18.74
20	18900	1880	QPSK	17.87	18.75
			16QAM	17.86	18.76
20	19100	1900	QPSK	17.89	18.77
			16QAM	17.89	18.74

**LTE Band 4 (Part 27):**

BW(MHz)	Channel	Frequency (MHz)	Modulation	99% Occupied Bandwidth (MHz)	26 dB Bandwidth (MHz)
1.4	19957	1710.7	QPSK	1.09	1.25
			16QAM	1.09	1.26
1.4	2.175	1732.5	QPSK	1.09	1.25
			16QAM	1.09	1.25
1.4	20393	1754.3	QPSK	1.09	1.25
			16QAM	1.09	1.26
3	19965	1711.5	QPSK	2.68	2.86
			16QAM	2.68	2.86
3	2.175	1732.5	QPSK	2.68	2.87
			16QAM	2.68	2.87
3	2.385	1753.5	QPSK	2.68	2.87
			16QAM	2.68	2.87
5	19975	1712.5	QPSK	4.49	4.79
			16QAM	4.49	4.78
5	20175	1732.5	QPSK	4.49	4.79
			16QAM	4.49	4.78
5	20375	1752.5	QPSK	4.48	4.77
			16QAM	4.49	4.79
10	2000	1715	QPSK	8.92	9.34
			16QAM	8.91	9.34
10	20175	1732.5	QPSK	8.91	9.34
			16QAM	8.91	9.32
10	20350	1750	QPSK	8.91	9.34
			16QAM	8.91	9.34
15	20025	1717.5	QPSK	13.44	14.23
			16QAM	13.44	14.22
15	20175	1732.5	QPSK	13.45	14.22
			16QAM	13.44	14.23
15	20325	1747.5	QPSK	13.44	14.23
			16QAM	13.44	14.22
20	20050	1720	QPSK	17.86	18.75
			16QAM	17.86	18.76
20	20175	1732.5	QPSK	17.86	18.76
			16QAM	17.86	18.76
20	20300	1745	QPSK	17.86	18.77
			16QAM	17.86	18.76

**LTE Band 5 (Part 22H):**

BW(MHz)	Channel	Frequency (MHz)	Modulation	99% Occupied Bandwidth (MHz)	26 dB Bandwidth (MHz)
1.4	20407	824.7	QPSK	1.09	1.25
			16QAM	1.09	1.25
1.4	20525	836.5	QPSK	1.09	1.25
			16QAM	1.09	1.25
1.4	20643	848.3	QPSK	1.09	1.25
			16QAM	1.09	1.25
3	20415	825.5	QPSK	2.68	2.86
			16QAM	2.68	2.86
3	20525	836.5	QPSK	2.68	2.86
			16QAM	2.68	2.86
3	20635	847.5	QPSK	2.68	2.86
			16QAM	2.68	2.87
5	20425	826.5	QPSK	4.49	4.79
			16QAM	4.48	4.77
5	20525	836.5	QPSK	4.49	4.78
			16QAM	4.48	4.79
5	20625	846.5	QPSK	4.48	4.78
			16QAM	4.49	4.78
10	20450	829.0	QPSK	8.92	9.33
			16QAM	8.91	9.34
10	20525	836.5	QPSK	8.9	9.34
			16QAM	8.9	9.3
10	20600	844.0	QPSK	8.92	9.33
			16QAM	8.91	9.33

**LTE Band 12 (Part 27):**

BW(MHz)	Channel	Frequency (MHz)	Modulation	99% Occupied Bandwidth (MHz)	26 dB Bandwidth (MHz)
1.4	23017	699.7	QPSK	1.09	1.25
			16QAM	1.09	1.25
1.4	23095	707.5	QPSK	1.09	1.24
			16QAM	1.09	1.25
1.4	23173	715.3	QPSK	1.09	1.24
			16QAM	1.09	1.25
3	23025	700.5	QPSK	2.68	2.86
			16QAM	2.68	2.85
3	23095	707.5	QPSK	2.68	2.86
			16QAM	2.68	2.87
3	23165	714.5	QPSK	2.68	2.86
			16QAM	2.68	2.86
5	23035	701.5	QPSK	4.49	4.78
			16QAM	4.48	4.78
5	23095	707.5	QPSK	4.48	4.76
			16QAM	4.48	4.78
5	23155	713.5	QPSK	4.49	4.79
			16QAM	4.49	4.78
10	23060	704	QPSK	8.9	9.3
			16QAM	8.9	9.3
10	23095	707.5	QPSK	8.89	9.31
			16QAM	8.89	9.3
10	23130	711	QPSK	8.92	9.33
			16QAM	8.91	9.31

**LTE Band 13 (Part 27)**

<b>BW(MHz)</b>	<b>Channel</b>	<b>Frequency (MHz)</b>	<b>Modulation</b>	<b>99% Occupied Bandwidth (MHz)</b>	<b>26 dB Bandwidth (MHz)</b>
5	23205	779.5	QPSK	4.49	4.79
			16QAM	4.49	4.77
5	23230	782.0	QPSK	4.48	4.78
			16QAM	4.48	4.78
5	23255	784.5	QPSK	4.48	4.78
			16QAM	4.48	4.78
10	23230	782.0	QPSK	8.91	9.33
			16QAM	8.9	9.31

**LTE Band 66 (Part 27):**

BW(MHz)	Channel	Frequency (MHz)	Modulation	99% Occupied Bandwidth (MHz)	26 dB Bandwidth (MHz)
1.4	131979	1710.7	QPSK	1.09	1.26
			16QAM	1.09	1.26
1.4	132321	1744.9	QPSK	1.09	1.25
			16QAM	1.09	1.26
1.4	132664	1779.2	QPSK	1.09	1.25
			16QAM	1.09	1.25
3	131987	1711.5	QPSK	2.68	2.86
			16QAM	2.68	2.86
3	132321	1744.9	QPSK	2.68	2.86
			16QAM	2.68	2.87
3	132656	1778.4	QPSK	2.68	2.86
			16QAM	2.68	2.87
5	131997	1712.5	QPSK	4.49	4.8
			16QAM	4.49	4.78
5	132321	1744.9	QPSK	4.49	4.79
			16QAM	4.48	4.79
5	132646	1777.4	QPSK	4.48	4.78
			16QAM	4.49	4.79
10	132022	1715	QPSK	8.91	9.32
			16QAM	8.91	9.34
10	132321	1744.9	QPSK	8.91	9.34
			16QAM	8.91	9.31
10	132621	1774.9	QPSK	8.92	9.32
			16QAM	8.91	9.34
15	132097	1722.5	QPSK	13.44	14.23
			16QAM	13.44	14.23
15	132321	1744.9	QPSK	13.45	14.22
			16QAM	13.44	14.22
15	132546	1772.5	QPSK	13.43	14.22
			16QAM	13.44	14.22
20	132072	1720	QPSK	17.86	18.74
			16QAM	17.86	18.76
20	132321	1744.9	QPSK	17.86	18.75
			16QAM	17.86	18.75
20	132471	1770	QPSK	17.85	18.74
			16QAM	17.86	18.75

**Test Plots**  
**LTE Band 2 (Part 24E)**



LTE band 2 - Low CH QPSK-1.4

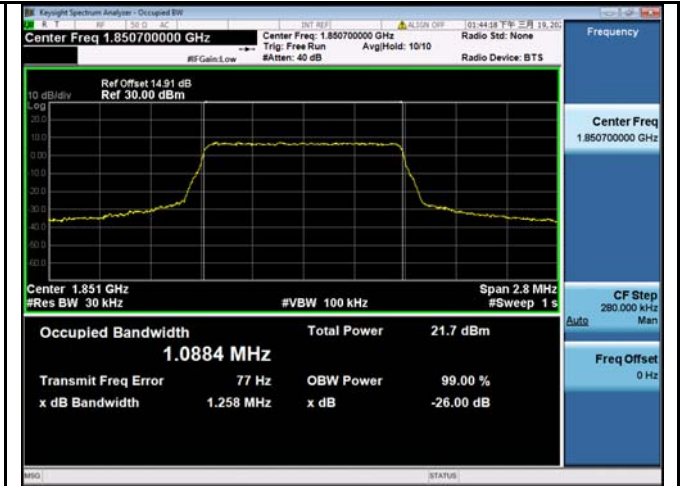

LTE band 2 - Low CH 16QAM-1.4



LTE band 2 - Middle CH QPSK-1.4

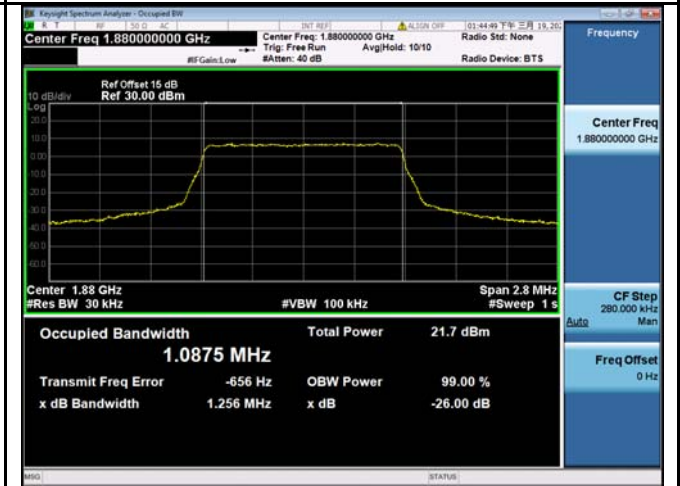

LTE band 2 - Middle CH 16QAM-1.4



LTE band 2 - High CH QPSK-1.4



LTE band 2 - High CH 16QAM-1.4



LTE band 2 - Low CH QPSK-3

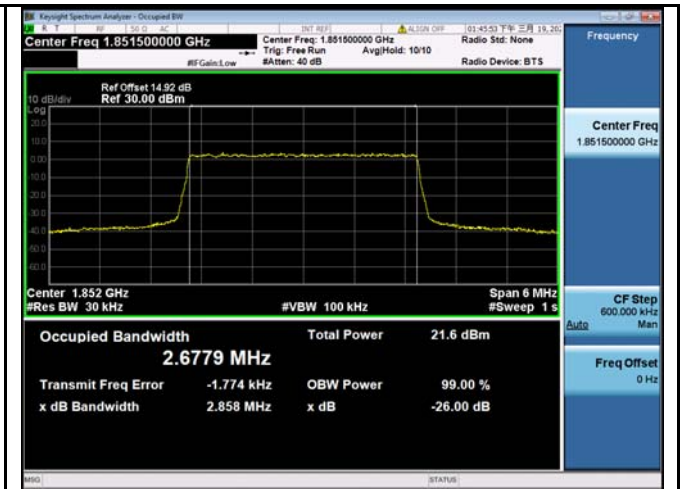

LTE band 2 - Low CH 16QAM-3

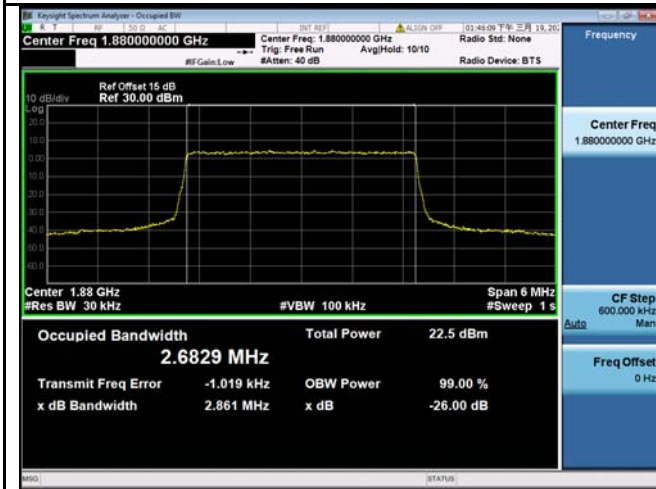

LTE band 2 - Middle CH QPSK-3

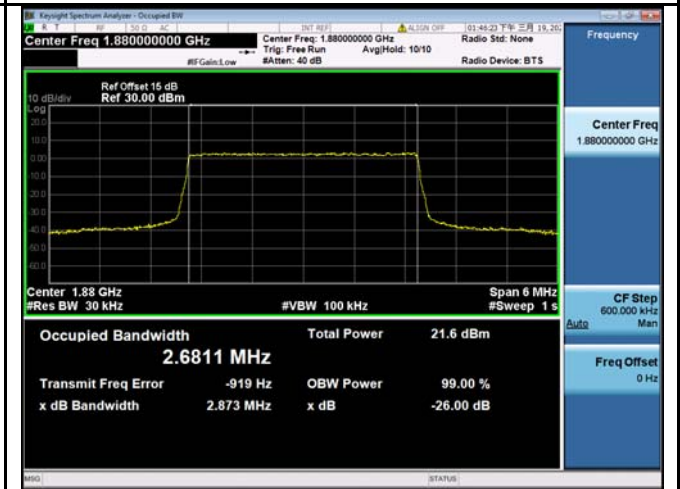

LTE band 2 - Middle CH 16QAM-3



LTE band 2 - High CH QPSK-3



LTE band 2 - High CH 16QAM-3



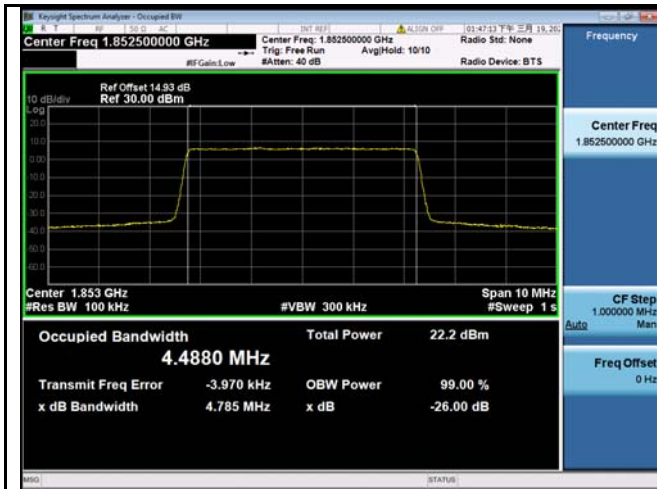

LTE band 2 - Low CH QPSK-5



LTE band 2 - Low CH 16QAM-5

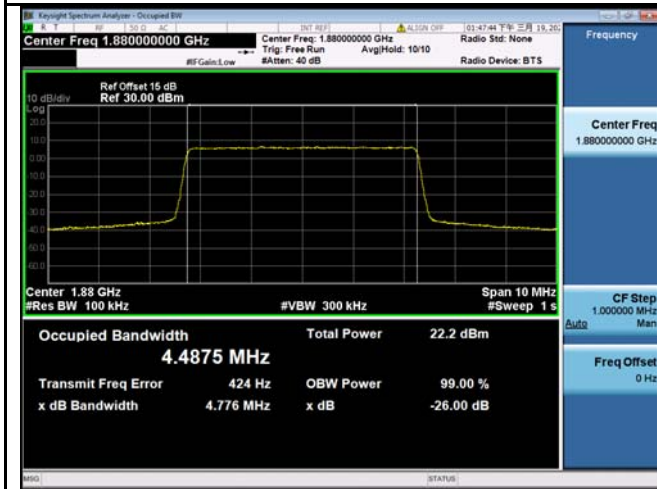

LTE band 2 - Middle CH QPSK-5

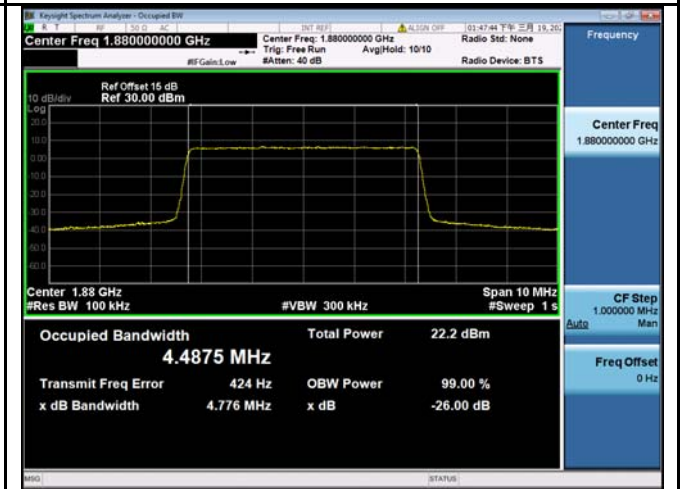

LTE band 2 - Middle CH 16QAM-5



LTE band 2 - High CH QPSK-5



LTE band 2 - High CH 16QAM-5

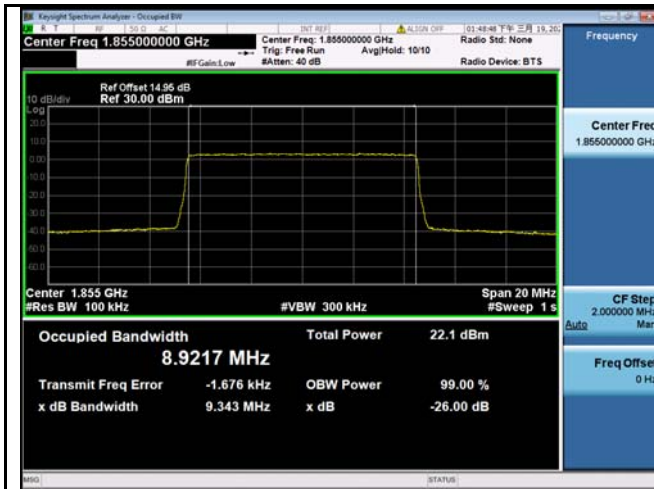

LTE band 2 - Low CH QPSK-10



LTE band 2 - Low CH 16QAM-10

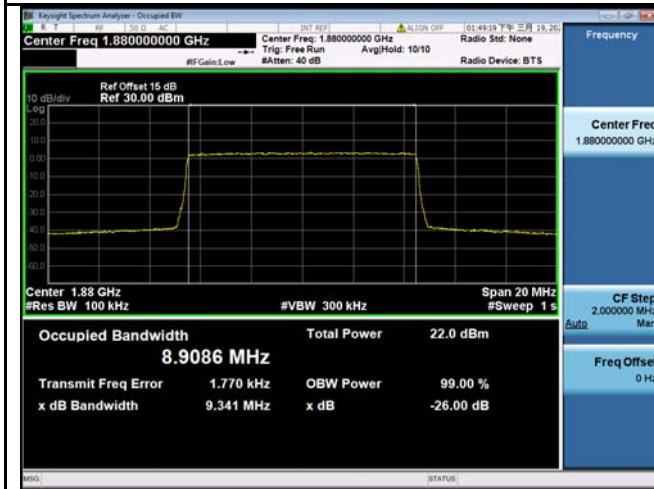

LTE band 2 - Middle CH QPSK-10

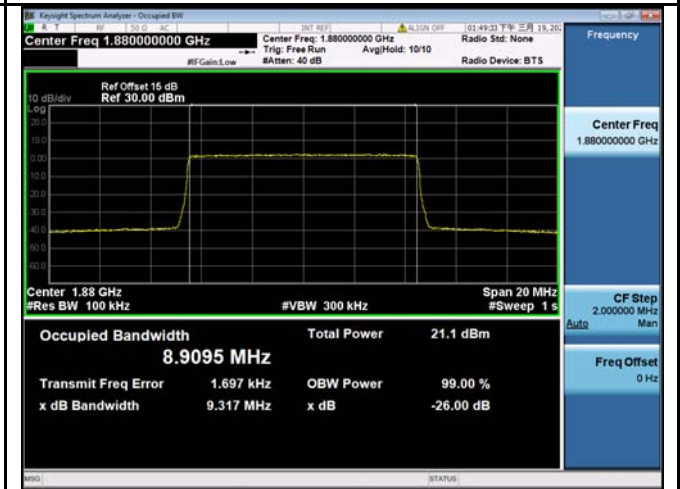

LTE band 2 - Middle CH 16QAM-10

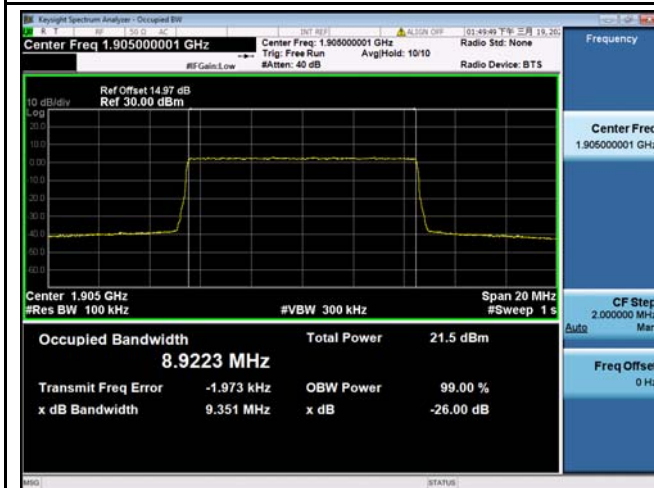

LTE band 2 - High CH QPSK-10



LTE band 2 - High CH 16QAM-10

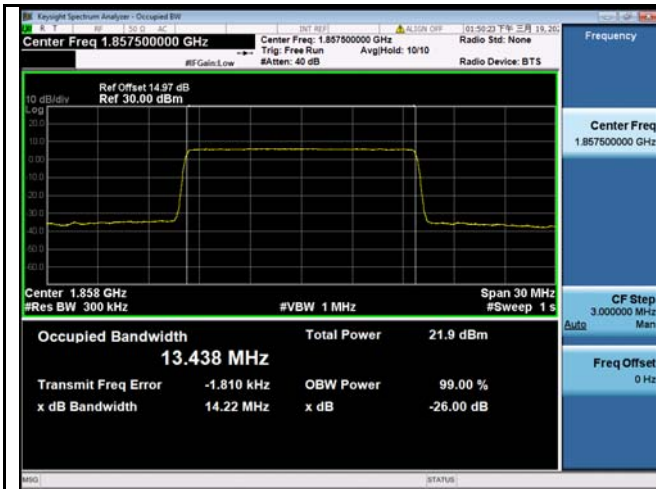

LTE band 2 - Low CH QPSK-15



LTE band 2 - Low CH 16QAM-15

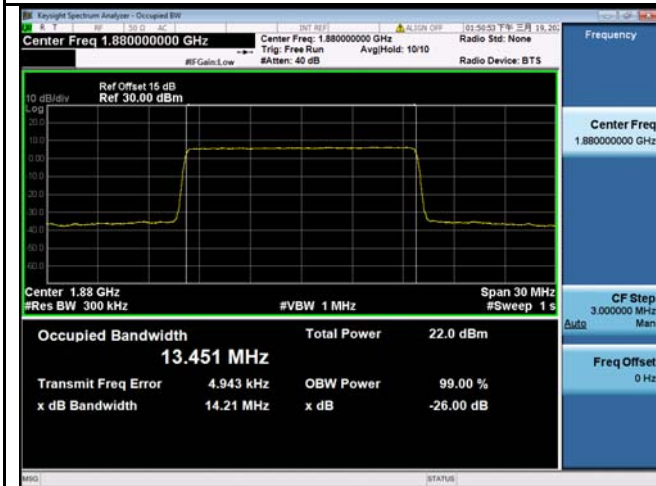

LTE band 2 - Middle CH QPSK-15

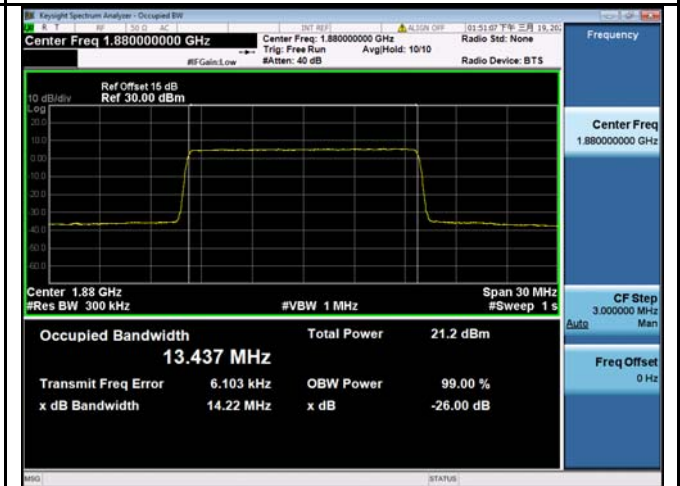

LTE band 2 - Middle CH 16QAM-15

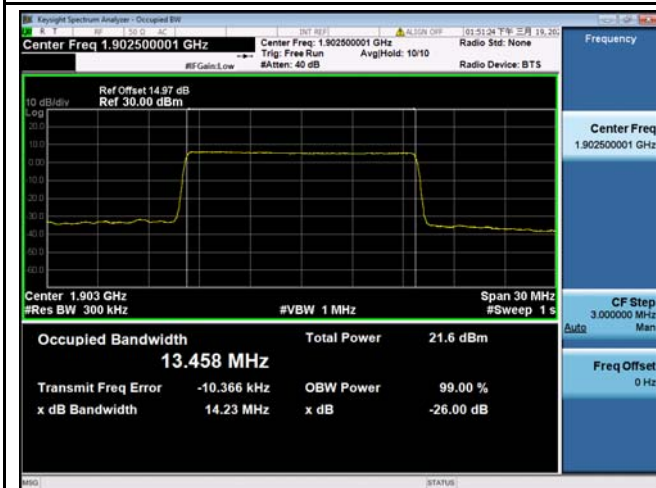

LTE band 2 - High CH QPSK-15

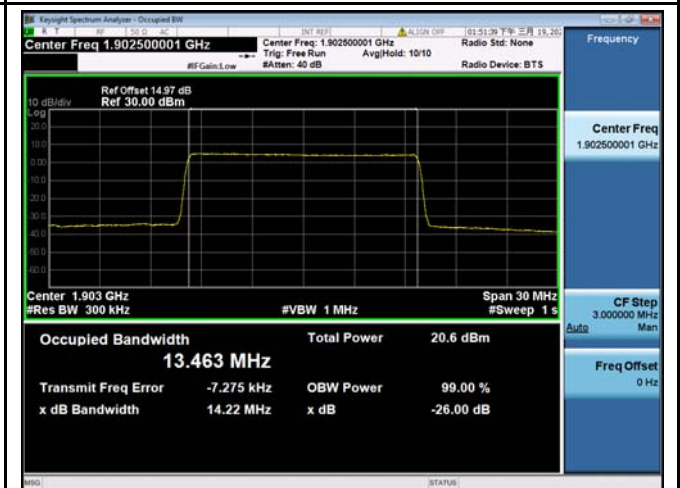

LTE band 2 - High CH 16QAM-15

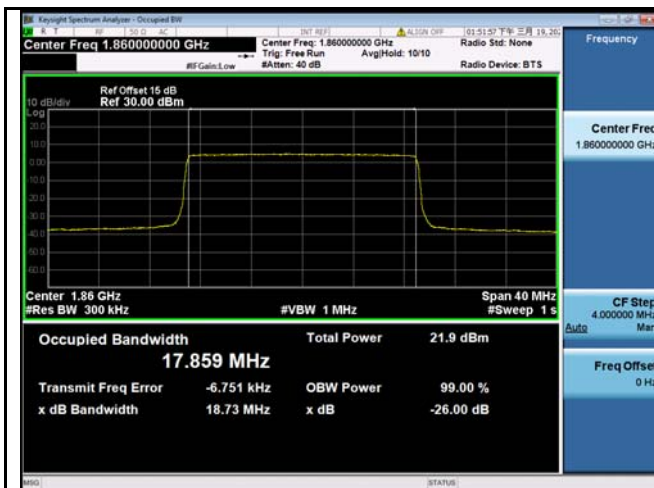

LTE band 2 - Low CH QPSK-20

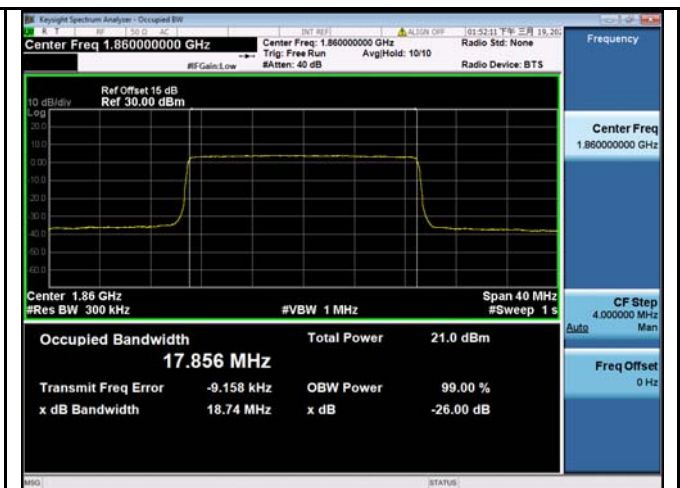

LTE band 2 - Low CH 16QAM-20



LTE band 2 - Middle CH QPSK-20



LTE band 2 - Middle CH 16QAM-20

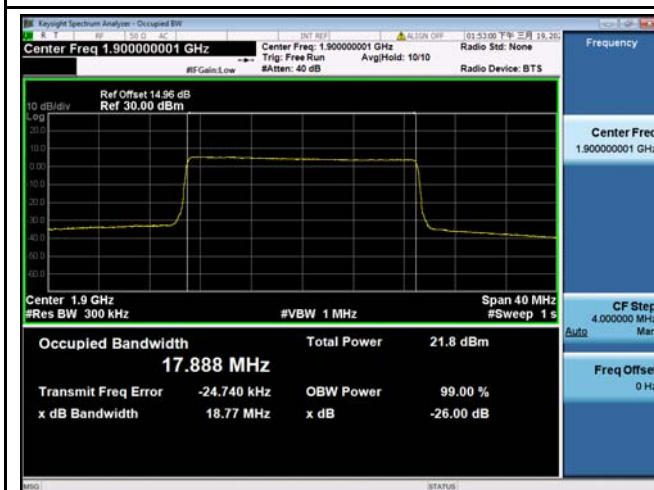

LTE band 2 - High CH QPSK-20

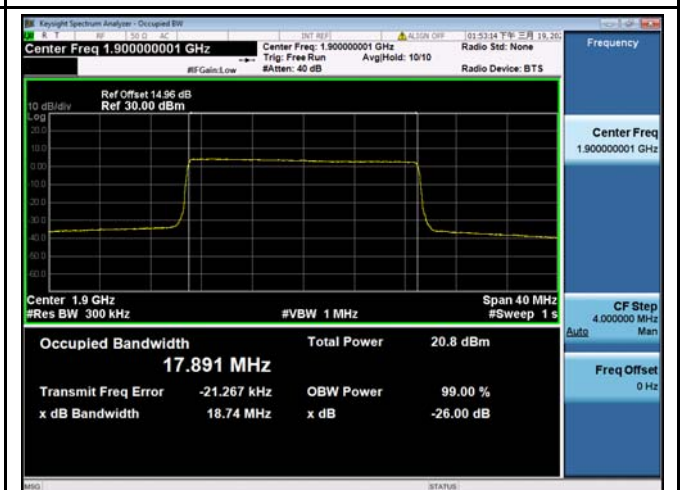

LTE band 2 - High CH 16QAM-20

LTE Band 4 (Part 27)

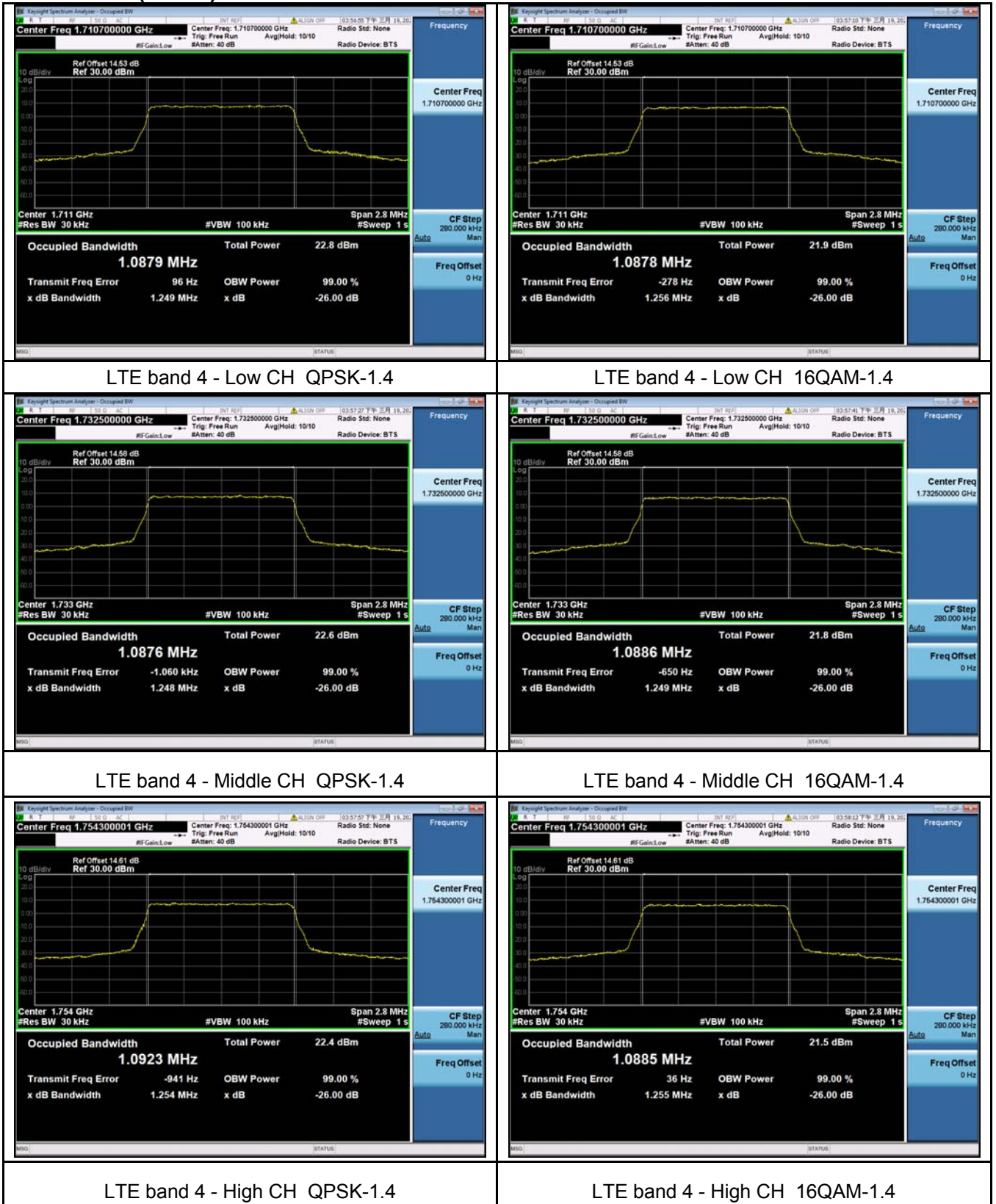

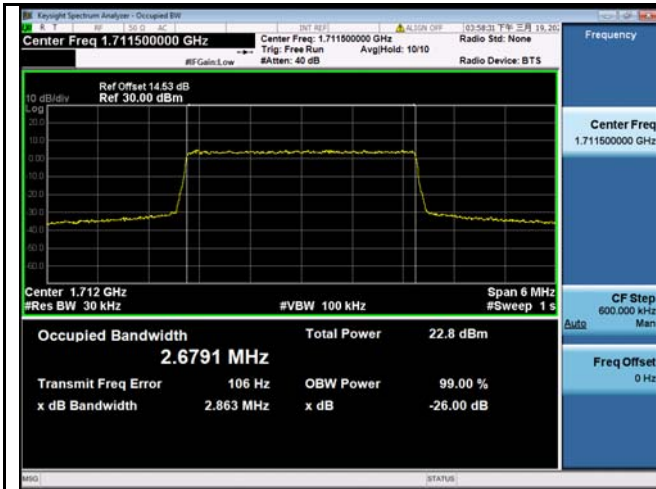

LTE band 4 - Low CH QPSK-3



LTE band 4 - Low CH 16QAM-3

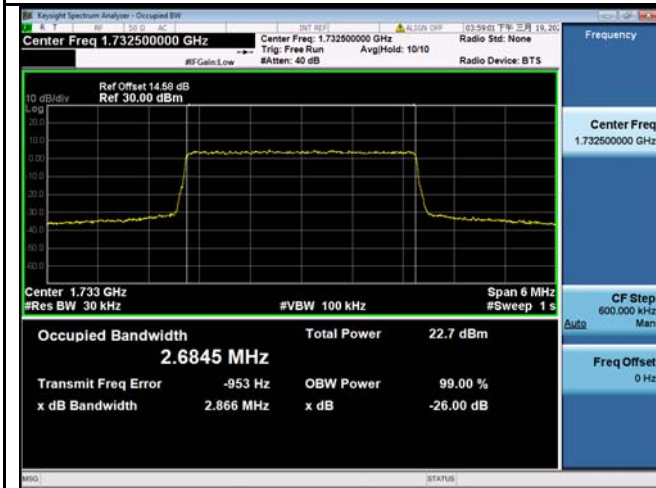

LTE band 4 - Middle CH QPSK-3

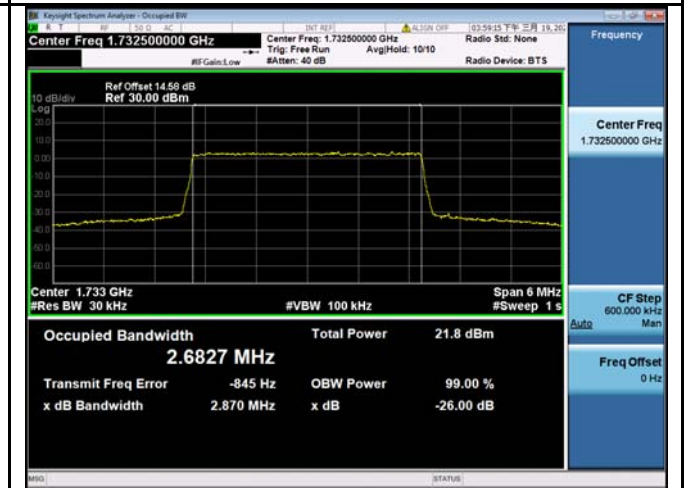

LTE band 4 - Middle CH 16QAM-3

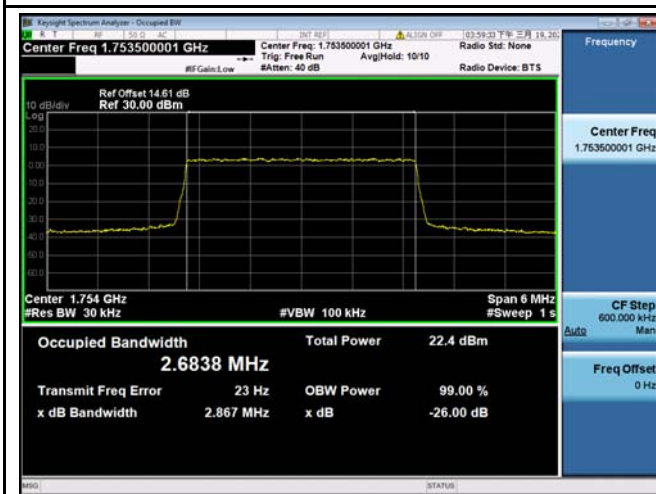

LTE band 4 - High CH QPSK-3

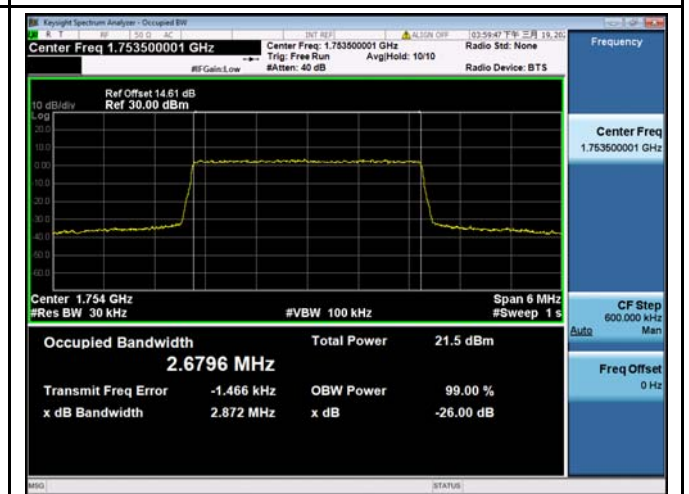

LTE band 4 - High CH 16QAM-3

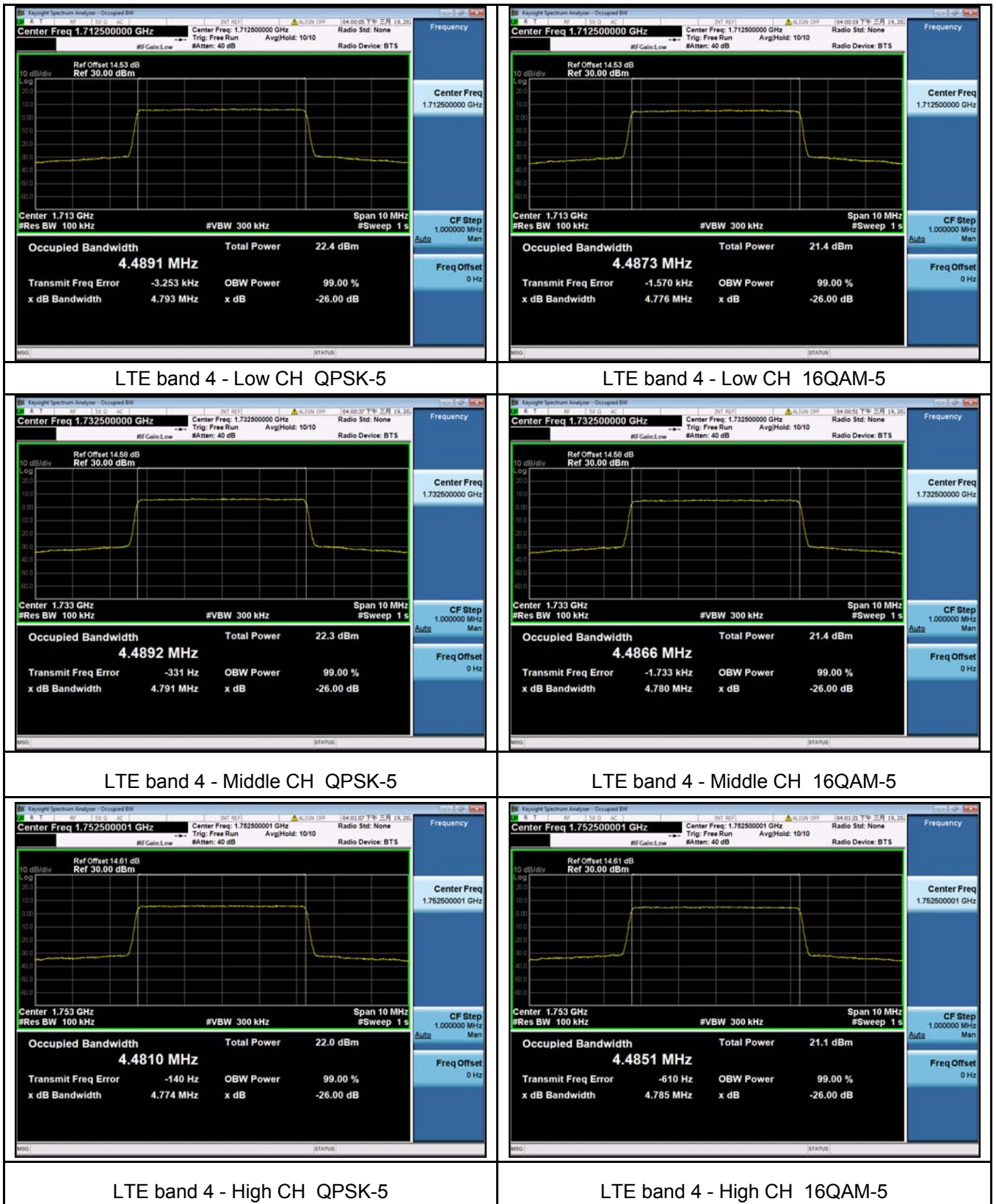

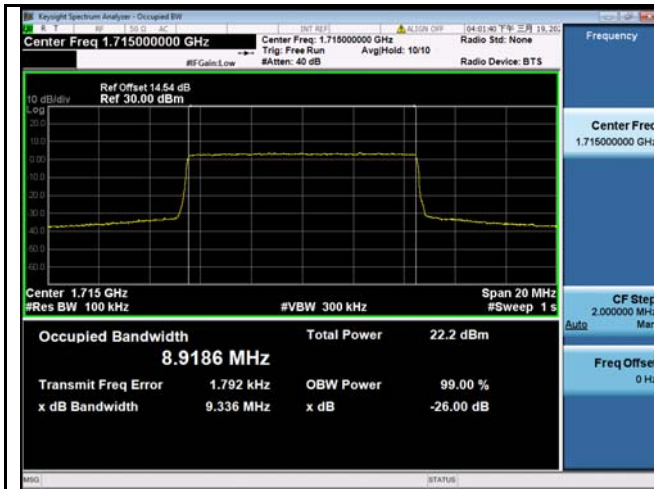

LTE band 4 - Low CH QPSK-10



LTE band 4 - Low CH 16QAM-10

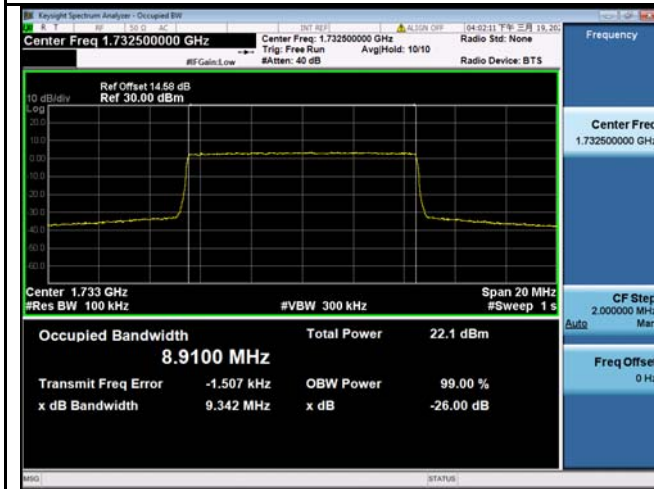

LTE band 4 - Middle CH QPSK-10



LTE band 4 - Middle CH 16QAM-10

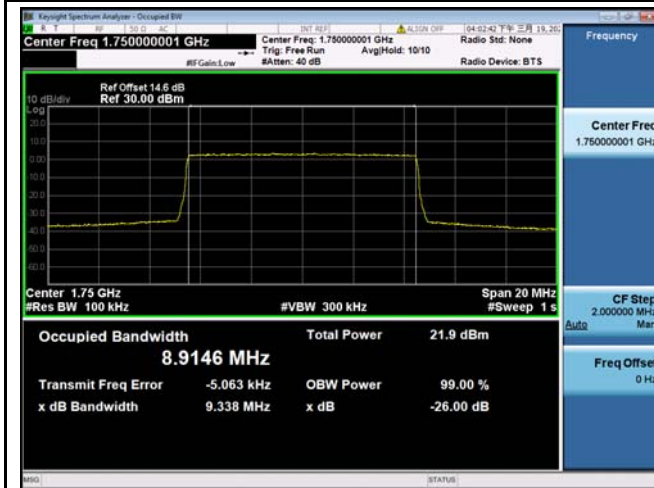

LTE band 4 - High CH QPSK-10



LTE band 4 - High CH 16QAM-10



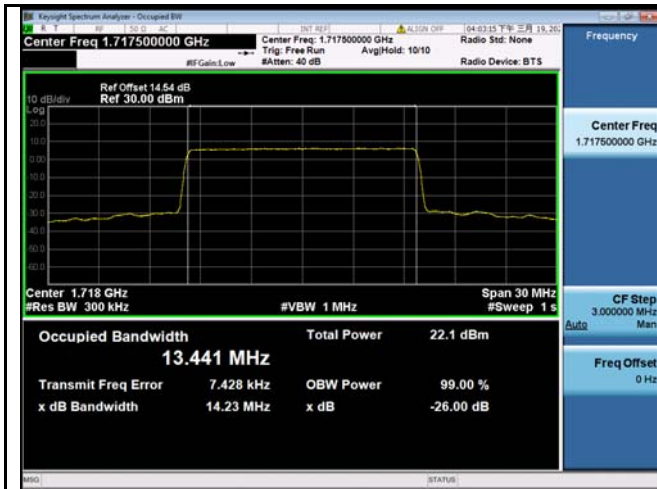

LTE band 4 - Low CH QPSK-15



LTE band 4 - Low CH 16QAM-15

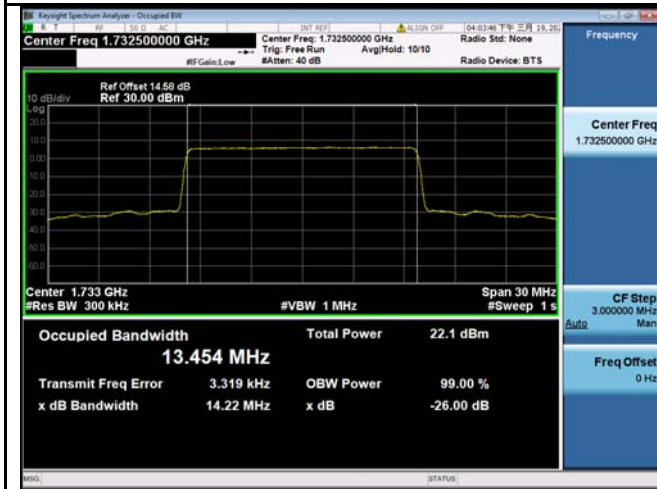

LTE band 4 - Middle CH QPSK-15



LTE band 4 - Middle CH 16QAM-15

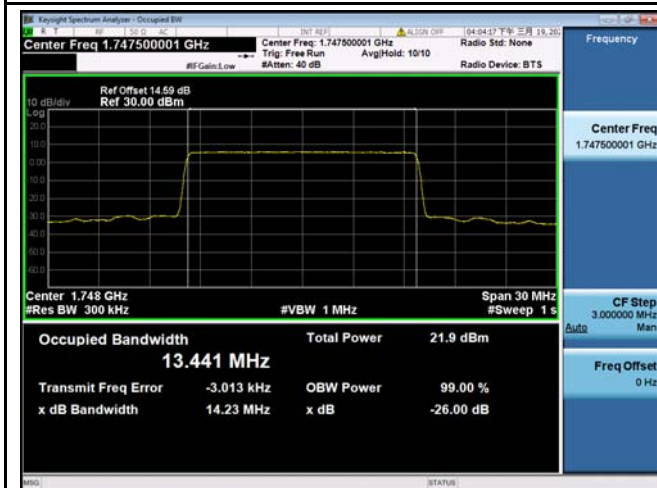

LTE band 4 - High CH QPSK-15

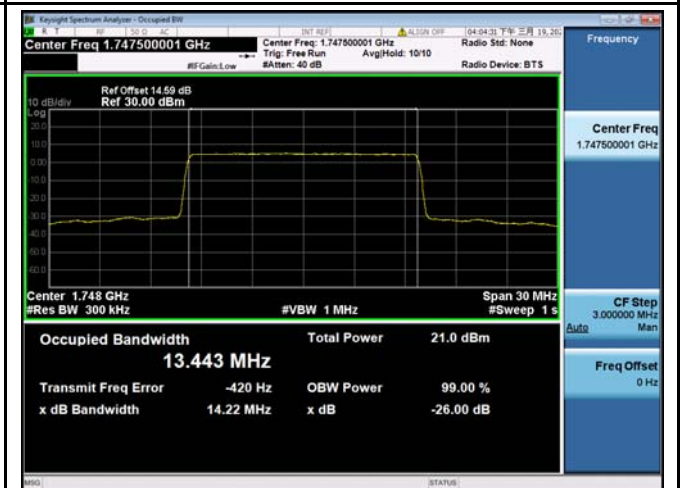

LTE band 4 - High CH 16QAM-15



LTE band 4 - Low CH QPSK-20



LTE band 4 - Low CH 16QAM-20



LTE band 4 - Middle CH QPSK-20

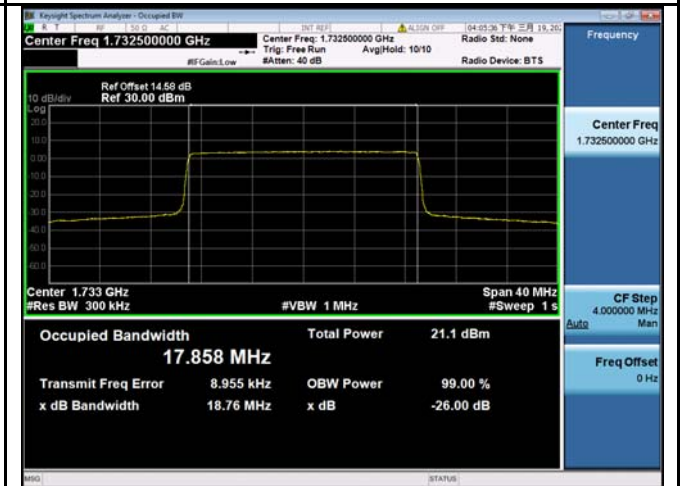

LTE band 4 - Middle CH 16QAM-20



LTE band 4 - High CH QPSK-20

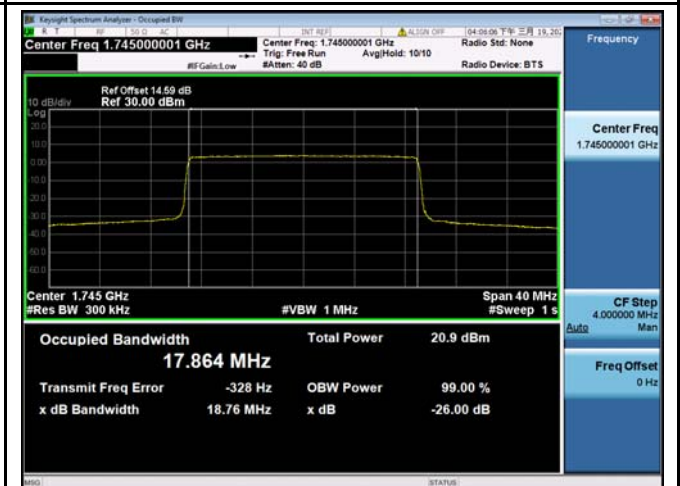

LTE band 4 - High CH 16QAM-20

LTE Band 5 (Part 22H)

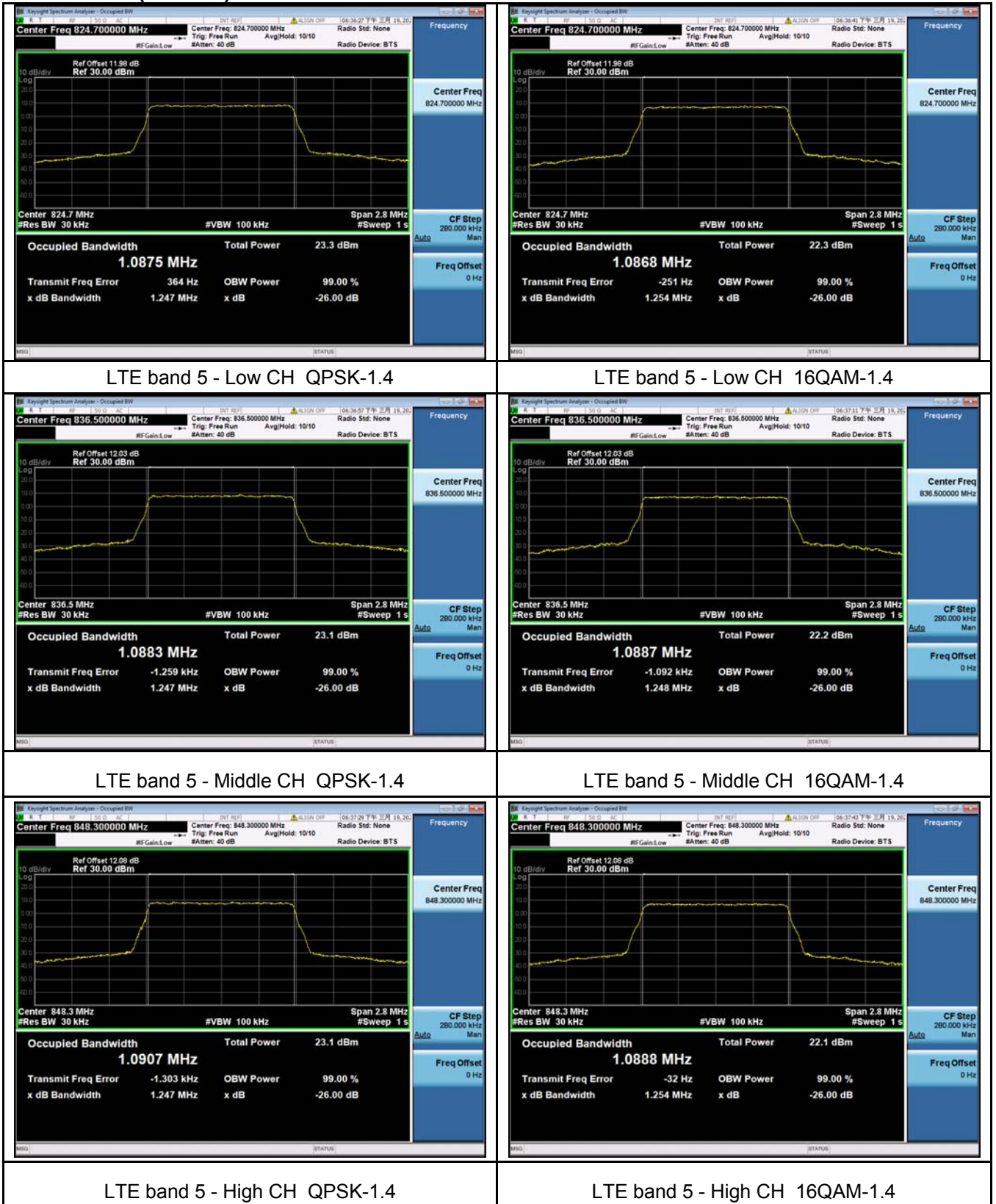





LTE band 5 - Low CH QPSK-5



LTE band 5 - Low CH 16QAM-5



LTE band 5 - Middle CH QPSK-5

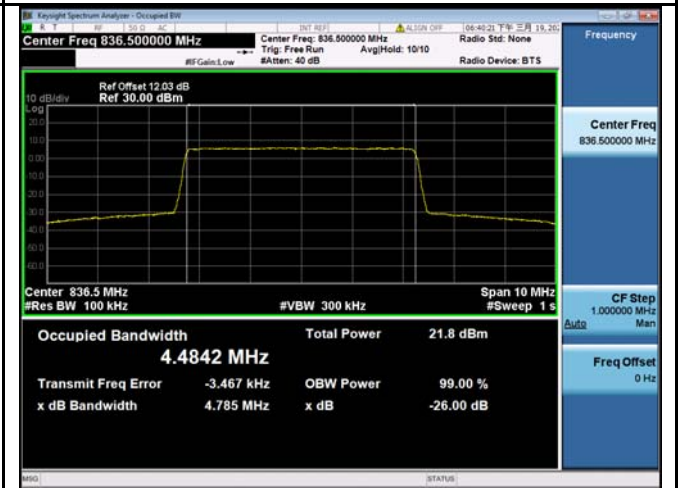

LTE band 5 - Middle CH 16QAM-5



LTE band 5 - High CH QPSK-5

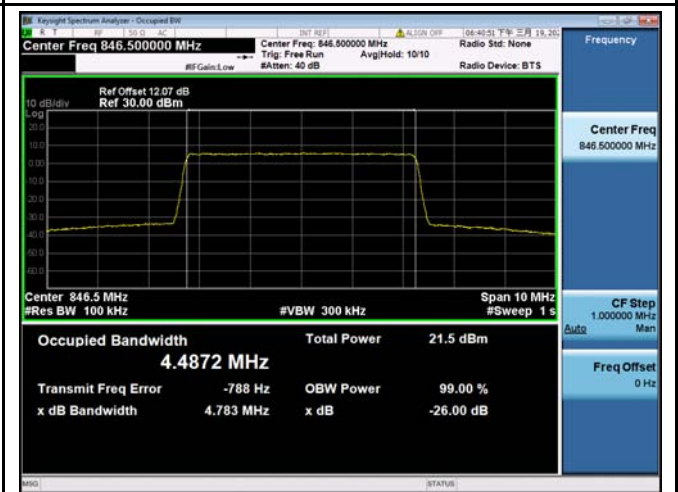

LTE band 5 - High CH 16QAM-5



LTE Band 12 (Part 27)



LTE band 12 - Low CH QPSK-1.4



LTE band 12 - Low CH 16QAM-1.4



LTE band 12 - Middle CH QPSK-1.4

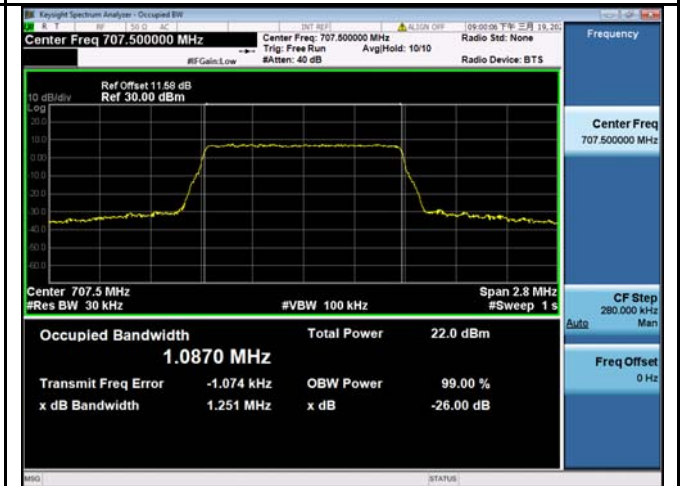

LTE band 12 - Middle CH 16QAM-1.4



LTE band 12 - High CH QPSK-1.4



LTE band 12 - High CH 16QAM-1.4

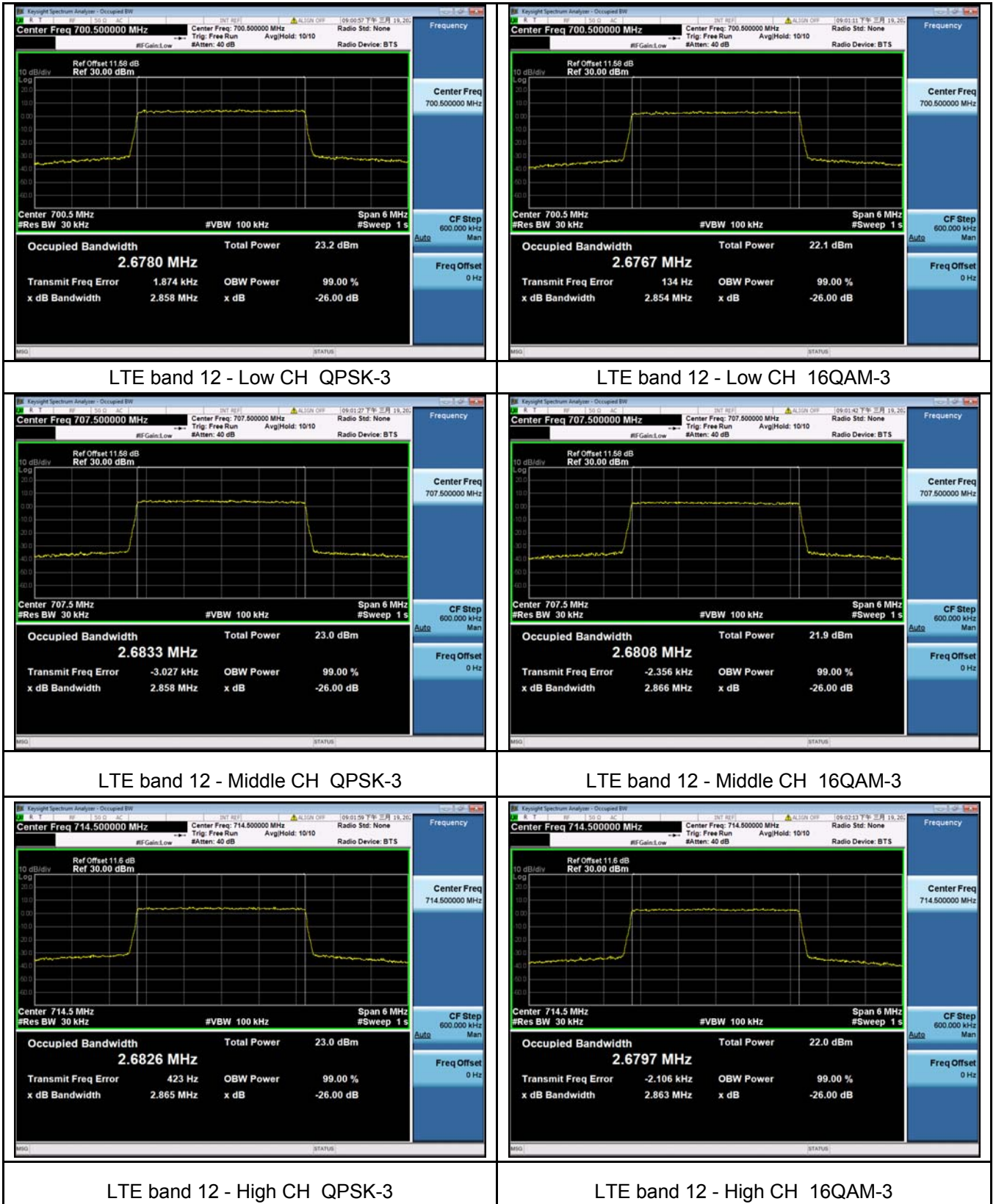





LTE band 12 - Low CH QPSK-5

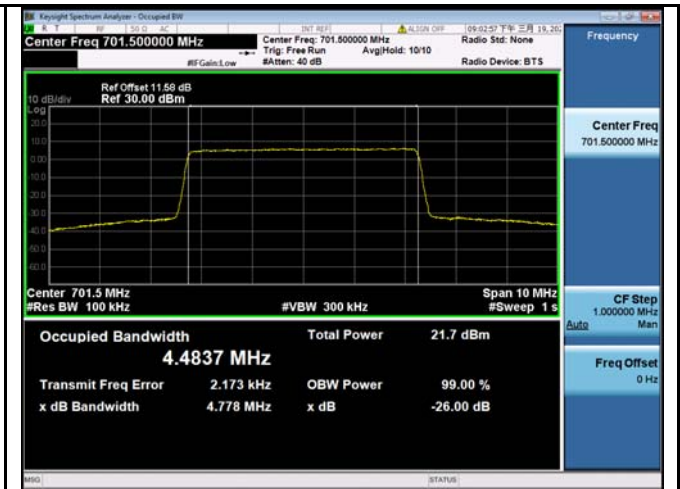

LTE band 12 - Low CH 16QAM-5

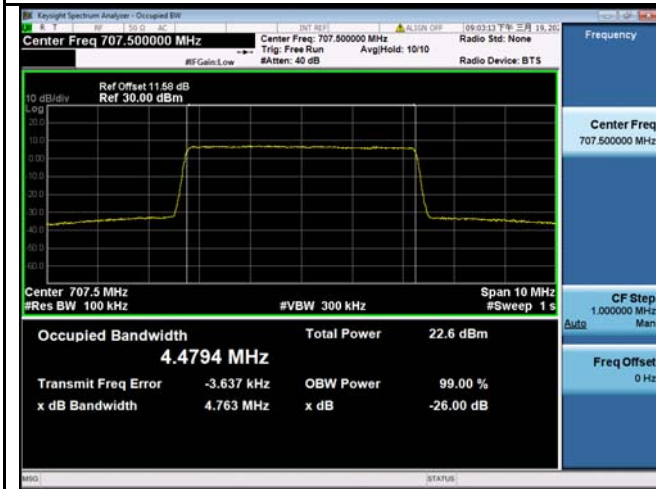

LTE band 12 - Middle CH QPSK-5

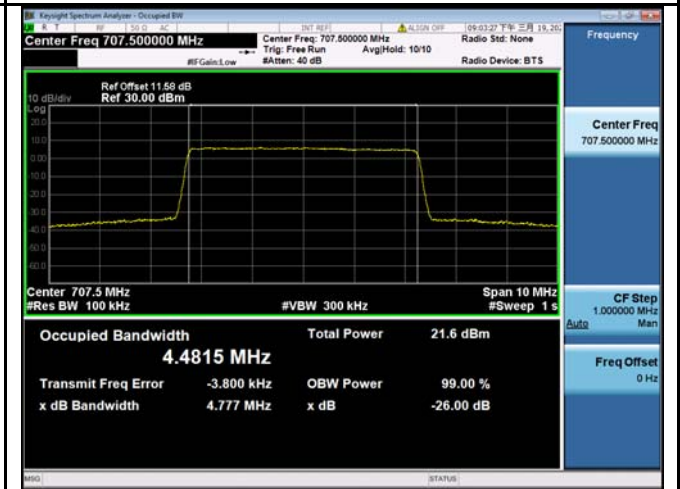

LTE band 12 - Middle CH 16QAM-5



LTE band 12 - High CH QPSK-5



LTE band 7 - High CH 16QAM-5



LTE band 12 - Low CH QPSK-10



LTE band 12 - Low CH 16QAM-10

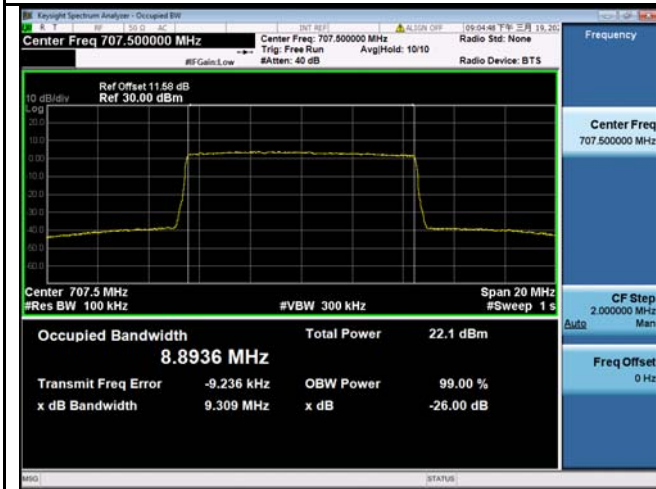

LTE band 12 - Middle CH QPSK-10



LTE band 12 - Middle CH 16QAM-10



LTE band 12 - High CH QPSK-10



LTE band 12 - High CH 16QAM-10

LTE Band 13 (Part 27)

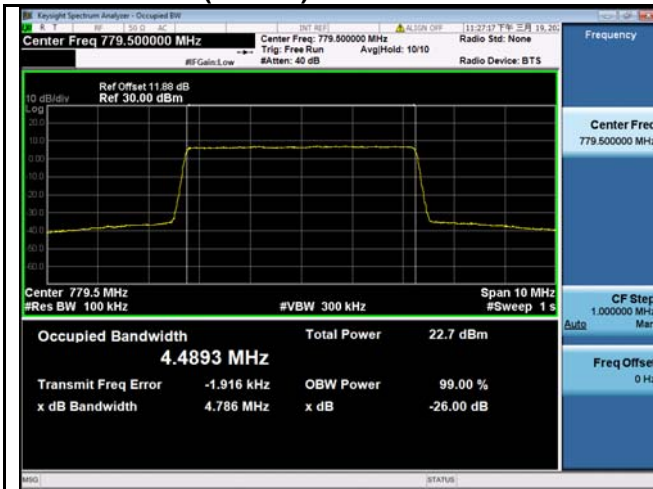

LTE band 13 - Low CH QPSK-5

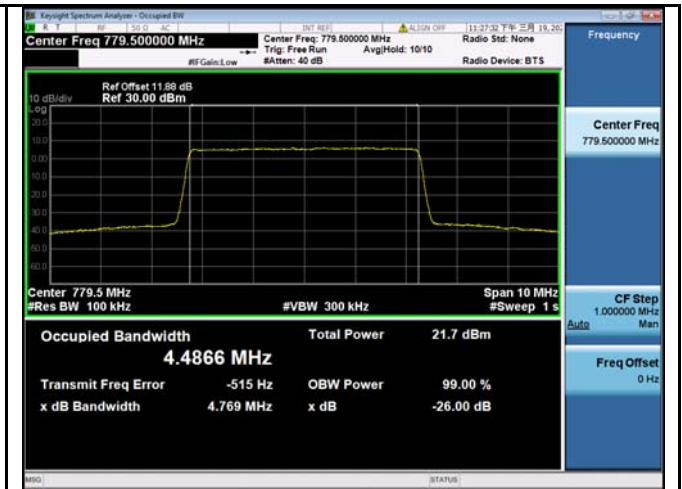

LTE band 13 - Low CH 16QAM-5



LTE band 13 - Middle CH QPSK-5

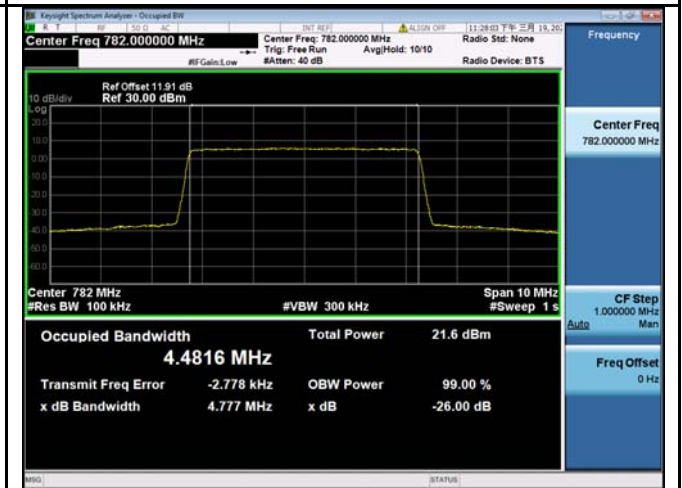

LTE band 13 - Middle CH 16QAM-5

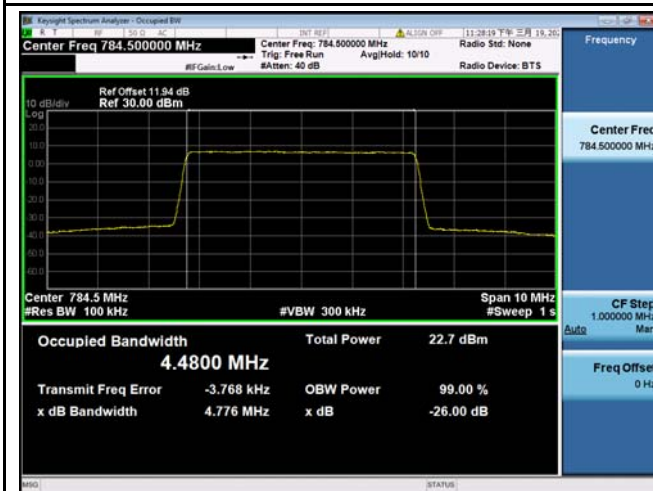

LTE band 13 - High CH QPSK-5

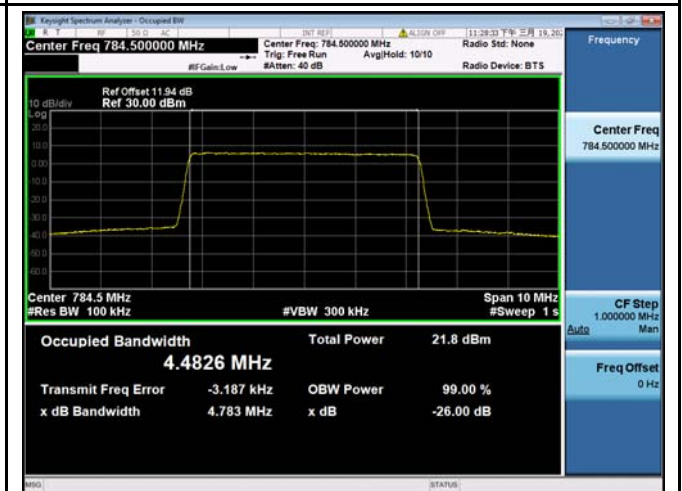

LTE band 13 - High CH 16QAM-5