

User Manual of LBCRB20 Crossbelt Robot

1. Brief Descriptions

LBCRB20 Crossbelt robot are mainly used for sorting in industries of express delivery services and warehousing logistics. Operated on special sorting platforms, these robots can receive and execute orders from servers to unload parcels and transport them to designated locations.

Product pictures:



2. Electrical Performance

Dimensions: 480*400*180mm

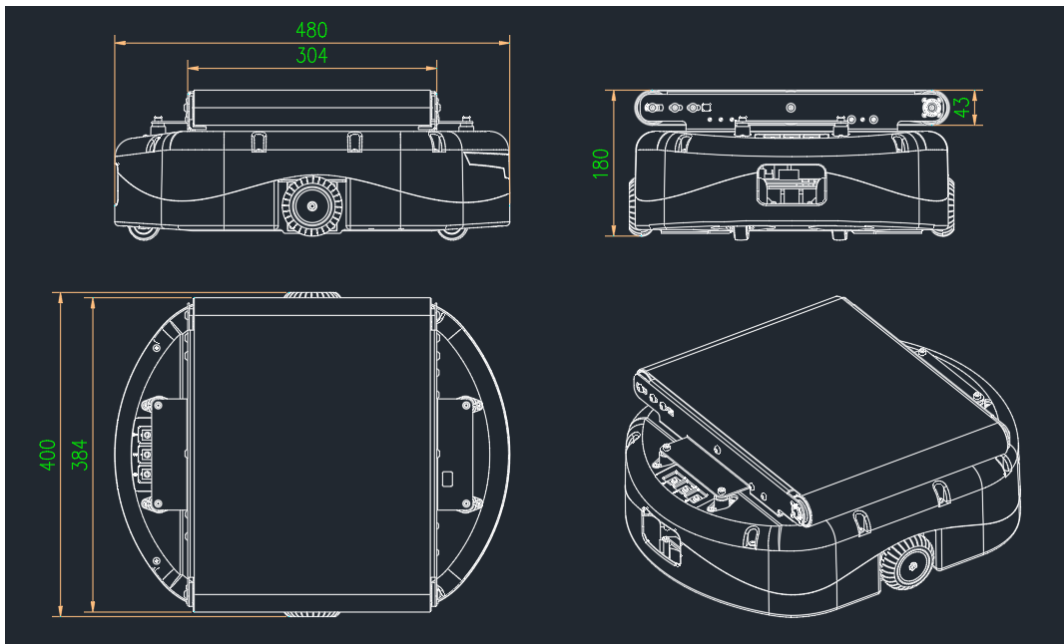

Rated Load: 20kg

Transfer way: Belt Drive

drive system: Servo Motor

Set speed: 1.5m/S

Set acceleration: 1.5m/S²

Communication mode: Wireless

Working temperature:-10 ~ 55°

Humidity: ≤95% (25°C) RH

LIB: 4.6VLi-Ion 92Wh

Charging voltage: 4.6-5.4V

MAX Charging current: 90A

Endurance: 3H

3.Descriptions of Product Modules

3.1.BMSP module

3.1.1.BMSPmodule through the chassis module read RFID(13.56M) tags, get the current location information, robot and wireless module to the server, the server based on the current robot position and state issued work instructions, robot analytic server command, and control the servo device, such as complete instruction execution, so as to realize the robot control and turning control, version control, movement, finally realizes the whole working process.

3.1.2. Power management module

In the power management module, commands for powering on and off robots can be obtained through wireless module. If a command for powering on robot is received, the power management module will switch on the power supply and power on all devices. When a command for powering off robot is received, the module will switch off the power supply and power off all devices. Meanwhile, all other devices will be switched to standby states with low power consumption except for the power management module.

3.2. Chassis module

Realize the detection of RFID(13.56M) code and location information detection, and upload. The data to the BMSP module through CAN communication.

3.3. Switching power module

Voltage conversion from 4.6V to 24V is under the control of the power management module, And protect the battery from overvoltage due to charging

3.4. Battery Pack and Charging Port

The battery pack is made of two 2.3V lithium batteries connected in series. The robot must be charged using special charging piles. The maximum charging current is 90A.

3.5. Servo Modules

At present, a robot has four servo modules, including left wheel, right wheel, front crossbelt and rear crossbelt, Used for walking control and unloading control

3.6. Buttons and LED Indicator Lights

Buttons are utilized for testing single robots and manually controlling shutdown. The LED indicator light is employed for indicating current state.

The functions of buttons and the indicator lights are shown as follows:



The bright red LED indicator lights can indicate malfunctions.

The states of the indicator lights are shown as follows:

SN	State of Indicator Light			Descriptions of State
	Operation	State	Standby	
1	off	off	off	Batteries are disconnected or power is not supplied.
2	off	off	on for 0.2s and off for 4s	Standby
3	on for 0.5s and off for 1.5s	off	off	Under the state of shutdown, orders from the server are not executed, and no malfunction is reported under this state.
4	on for 0.5s and off for 0.5s	off	off	Under operation, receiving commands from the server
5	on for 0.5s and off for 0.5s	on	off	Under operation, waiting for commands from the server
6	on for 0.2s and off for 0.2s	on for 0.2s and off for 0.2s	on for 0.2s and off for 0.2s	Malfunctioning, generally because RFID can't be recognized.
7	Any light is always on			Enter the function mode.
8	Any light is on for 0.2s and off 0.2s			Mode of function selection

An Introduction to Functions of Buttons:

No button will function when a robot is under the No.1 State shown on the above table.

Current State No. (see above table)	Buttons	Description of Functions
1	Any	No function
2	Press [A] + [C] for 3s	Power on and wake the robot up
3-8	Press [B] + [C] for 5s	Power off and switch the robot to a standby state
3-6	Press [A]	The robot enters the operation state
3-6	Press [B]	The robot enters the shutdown state
3-6	Press [C]	Enter the state of function selection (No.8 state). Later, you can switch to another function once you press [Function] and choose any one from No.1 to No.7 functions
8	Press [A]	Enter the state of current function (No.7 State)
8	Press [B]	Exit from the state of function selection and return to the state of shutdown
7	Press [A]	Start executing the current function
7	Press [B]	Suspend the execution of the current function
7	Press [C]	Exit from the current function and return to the state of shutdown

Notes: All above operations are manual manipulations of a single robot for maintenance or testing. No manipulation will be needed when a robot is under normal operation.

4.User Instructions

Robots are actuators of sorting systems and their normal operations require the support of the whole sorting platform.

During their normal work, no manipulation is needed at all, and all of their operations are completed on the server.

4.1.Powering on

Robots are powered on with server software and switching devices. You can send a command for powering on a robot with switching software of the server through the LBAP-102LU wireless device of the switching device. Then, the robot can be automatically powered on.

4.2.Sorting

Robot sorting can be realized through the server. You can control the robots and exchange data via wireless module with server software.

The server will try connecting all robots which have been powered on. After normal connection, the server will keep being connected with the robots, acquire information about robots' current position via RFID codes and control robots' walking or flapping according to state of current sorting platform.

4.3.Powering off

Robots are powered off with server software and switching devices. The robots can be powered off by issuing corresponding commands to them through the LBAP-102LU wireless device of the switching device with switching software of the server.

The robot will automatically shut down when it detects that the battery voltage is lower than 3.8v.

FCC Statement

Any Changes or modifications not expressly approved by the party responsible for compliance could void the user's authority to operate the equipment.

This device complies with part 15 of the FCC Rules. Operation is subject to the following two conditions: (1) This device may not cause harmful interference, and (2) This device must accept any interference received, including interference that may cause undesired operation.