



FCC 47 CFR PART 15 SUBPART C

CERTIFICATION TEST REPORT

For

Repeater

MODEL NUMBER: CT103

FCC ID: 2AQPUCT103

REPORT NUMBER: 4788510983.1-1

ISSUE DATE: July 31, 2018

Prepared for

**Lin Man Power Technology Inc.,
No.6 3rd street, Meridian Industrial Complex Balibago, Sta. Rosa City , Laguna ,
Philippine.**

Prepared by

**UL Verification Services (Guangzhou) Co., Ltd, Song Shan Lake Branch
Building 10, Innovation Technology Park, No. 1, Li Bin Road,
Song Shan Lake Hi-Tech Development Zone, Dongguan, People's Republic of China
Tel: +86 769-22038881
Fax: +86 769 33244054
Website: www.ul.com**



Revision History

<u>Rev.</u>	<u>Issue Date</u>	<u>Revisions</u>	<u>Revised By</u>
--	07/31/2018	Initial Issue	



Summary of Test Results			
Clause	Test Items	FCC/IC Rules	Test Results
1	6db DTS Bandwidth	FCC 15.247 (a) (2)	PASS
2	Peak Conducted Power	FCC 15.247 (b) (3)	PASS
3	Power Spectral Density	FCC 15.247 (e)	PASS
4	Conducted Band edge And Spurious emission	FCC 15.247 (d)	PASS
5	Radiated Band edges and Spurious emission	FCC 15.247 (d) FCC 15.209 FCC 15.205	PASS
6	Conducted Emission Test For AC Power Port	FCC 15.207	PASS
7	Antenna Requirement	FCC 15.203	PASS



TABLE OF CONTENTS

1. ATTESTATION OF TEST RESULTS	6
2. TEST METHODOLOGY	7
3. FACILITIES AND ACCREDITATION	7
4. CALIBRATION AND UNCERTAINTY	8
4.1. <i>MEASURING INSTRUMENT CALIBRATION</i>	8
4.2. <i>MEASUREMENT UNCERTAINTY</i>	8
5. EQUIPMENT UNDER TEST	9
5.1. <i>DESCRIPTION OF EUT</i>	9
5.2. <i>MAXIMUM OUTPUT POWER</i>	9
5.3. <i>CHANNEL LIST</i>	9
5.4. <i>TEST CHANNEL CONFIGURATION</i>	10
5.5. <i>THE WORSE CASE POWER SETTING PARAMETER</i>	10
5.6. <i>DESCRIPTION OF AVAILABLE ANTENNAS</i>	10
5.7. <i>TEST ENVIRONMENT</i>	10
5.8. <i>DESCRIPTION OF TEST SETUP</i>	11
6. MEASURING INSTRUMENT AND SOFTWARE USED	12
7. MEASUREMENT METHODS	13
8. ANTENNA PORT TEST RESULTS	14
8.1. <i>ON TIME AND DUTY CYCLE</i>	14
8.2. <i>6 dB DTS BANDWIDTH</i>	15
8.3. <i>PEAK CONDUCTED OUTPUT POWER</i>	18
8.4. <i>POWER SPECTRAL DENSITY</i>	20
8.5. <i>CONDUCTED BANDEDGE AND SPURIOUS EMISSIONS</i>	24
9. RADIATED TEST RESULTS	29
9.1. <i>RESTRICTED BANDEDGE</i>	34
9.2. <i>SPURIOUS EMISSIONS (1~10GHz)</i>	38
9.3. <i>SPURIOUS EMISSIONS 30M ~ 1 GHz</i>	50
9.4. <i>SPURIOUS EMISSIONS BELOW 30M</i>	52
10. AC POWER LINE CONDUCTED EMISSIONS	56



11. ANTENNA REQUIREMENTS.....59



1. ATTESTATION OF TEST RESULTS

Applicant Information

Company Name: Lin Man Power Technology Inc.,
Address: No.6 3rd street, Meridian Industrial Complex Balibago, Sta. Rosa City , Laguna , Philippine.

Manufacturer Information

Company Name: Lin Man Power Technology Inc.,
Address: No.6 3rd street, Meridian Industrial Complex Balibago, Sta. Rosa City , Laguna , Philippine.

EUT Description

Product Name Repeater
Brand Name ENERTEK
Model Name CT103
Sample Status Normal
Sample Received date July 04, 2018
Date Tested July 05~ 25, 2018

APPLICABLE STANDARDS	
STANDARD	TEST RESULTS
CFR 47 Part 15 Subpart C	PASS

Tested By:

Jacky Jiang
Engineer Project Associate

Check By:

Shawn Wen
Laboratory Leader

Approved By:

Stephen Guo
Laboratory Manager



2. TEST METHODOLOGY

The tests documented in this report were performed in accordance with KDB414788 D01 Radiated Test Site v01r01, ANSI C63.10-2013, KDB558074 D01 DTS Meas Guidance v05, FCC CFR 47 Part 2, FCC CFR 47 Part 15.

3. FACILITIES AND ACCREDITATION

Accreditation Certificate	<p>A2LA (Certificate No.: 4102.01) UL Verification Services (Guangzhou) Co., Ltd. Song Shan Lake Branch. has been assessed and proved to be in compliance with A2LA.</p> <p>FCC (FCC Designation No.: CN1187) UL Verification Services (Guangzhou) Co., Ltd. Song Shan Lake Branch. Has been recognized to perform compliance testing on equipment subject to the Commission's Declaration of Conformity (DoC) and Certification rules</p> <p>IC(Company No.: 21320) UL Verification Services (Guangzhou) Co., Ltd. Song Shan Lake Branch. has been registered and fully described in a report filed with ISED. The Company Number is 21320.</p> <p>VCCI (Registration No.: G-20019, R-20004, C-20012 and T-20011) UL Verification Services (Guangzhou) Co., Ltd. Song Shan Lake Branch. has been assessed and proved to be in compliance with VCCI, the Membership No. is 3793. Facility Name: Chamber D, the VCCI registration No. is G-20019 and R-20004 Shielding Room B , the VCCI registration No. is C-20012 and T-20011</p>
---------------------------	---

Note:

1. All tests measurement facilities use to collect the measurement data are located at Building 10, Innovation Technology Park, Song Shan Lake Hi tech Development Zone, Dongguan, 523808, China
2. The test anechoic chamber in UL Verification Services (Guangzhou) Co., Ltd. Song Shan Lake Branch had been calibrated and compared to the open field sites and the test anechoic chamber is shown to be equivalent to or worst case from the open field site.
3. For below 30MHz, lab had performed measurements at test anechoic chamber and comparing to measurements obtained on an open field site. And these measurements below 30MHz had been correlated to measurements performed on an OATS.



4. CALIBRATION AND UNCERTAINTY

4.1. MEASURING INSTRUMENT CALIBRATION

The measuring equipment utilized to perform the tests documented in this report has been calibrated in accordance with the manufacturer's recommendations, and is traceable to recognize national standards.

4.2. MEASUREMENT UNCERTAINTY

Where relevant, the following measurement uncertainty levels have been estimated for tests performed on the apparatus:

Test Item	Uncertainty
Uncertainty for Conduction emission test	2.90dB
Uncertainty for Radiation Emission test(include Fundamental emission) (9KHz-30MHz)	2.2dB
Uncertainty for Radiation Emission test(include Fundamental emission) (30MHz-1GHz)	4.52dB
Uncertainty for Radiation Emission test (1GHz to 26GHz)(include Fundamental emission)	5.04dB(1-6GHz)
	5.30dB (6GHz-18Gz)
	5.23dB (18GHz-26Gz)
Note: This uncertainty represents an expanded uncertainty expressed at approximately the 95% confidence level using a coverage factor of k=2.	



5. EQUIPMENT UNDER TEST

5.1. DESCRIPTION OF EUT

Equipment	Repeater		
Model Name	CT103		
Product Description	Operation Frequency	915.25 MHz ~ 917.75 MHz	
	Modulation Type	Lora	
Power Supply	AC 230V 60Hz		
Hardware Version	V2.0		
Software Version	V0213		

5.2. MAXIMUM OUTPUT POWER

Mode	Frequency (MHz)	Channel Number	Max Output Power (dBm)	EIRP (dBm)
Lora	915.25-917.75	1-51[51]	12.037	12.037

5.3. CHANNEL LIST

Channel	Frequency(MHz)	Channel	Frequency(MHz)	Channel	Frequency(MHz)
1	915.25	18	916.10	35	916.95
2	915.30	19	916.15	36	917.00
3	915.35	20	916.20	37	917.05
4	915.40	21	916.25	38	917.10
5	915.45	22	916.30	39	917.15
6	915.50	23	916.35	40	917.20
7	915.55	24	916.40	41	917.25
8	915.60	25	916.45	42	917.30
9	915.65	26	916.50	43	917.35
10	915.70	27	916.55	44	917.40
11	915.75	28	916.60	45	917.45
12	915.80	29	916.65	46	917.50
13	915.85	30	916.70	47	917.55
14	915.90	31	916.75	48	917.60
15	915.95	32	916.80	49	917.65
16	916.00	33	916.85	50	917.70
17	916.05	34	916.90	51	917.75



5.4. TEST CHANNEL CONFIGURATION

Test Mode	Test Channel	Frequency
Lora	CH 1, CH 26, CH 51	915.25MHz, 916.50MHz, 917.75MHz

5.5. THE WORSE CASE POWER SETTING PARAMETER

The Worse Case Power Setting Parameter under 915.25-917.75MHz Band				
Test Software		SmartSet		
Modulation Type	Transmit Antenna Number	Test Channel		
		CH 1	CH 26	CH 51
Lora	1	Default	Default	Default

5.6. DESCRIPTION OF AVAILABLE ANTENNAS

Ant.	Frequency (MHz)	Antenna Type	Antenna Gain (dBi)
1	915.25-917.75	Spring Antenna	0.0

Test Mode	Transmit and Receive Mode	Description
Lora	1TX, 1RX	Chain 1 can be used as transmitting/receiving antenna.

5.7. TEST ENVIRONMENT

Environment Parameter	Selected Values During Tests	
Relative Humidity	55 ~ 65%	
Atmospheric Pressure:	1025Pa	
Temperature	TN	23 ~ 28°C
	VL	N/A
Voltage :	VN	AC 230V 60Hz
	VH	N/A

Note: VL= Lower Extreme Test Voltage
 VN= Nominal Voltage
 VH= Upper Extreme Test Voltage
 TN= Normal Temperature

5.8. DESCRIPTION OF TEST SETUP

SUPPORT EQUIPMENT

Item	Equipment	Brand Name	Model Name	P/N
1	PC	Dell	Vostro 3902	8KNDDDB2
2	RS485 TO USB Cable	N/A	N/A	N/A

I/O CABLES

Cable No	Port	Connector Type	Cable Type	Cable Length(m)	Remarks
1	USB	N/A	N/A	0.15	N/A

ACCESSORY

Item	Accessory	Brand Name	Model Name	Description
1	N/A	N/A	N/A	N/A

TEST SETUP

The EUT can work in an engineer mode with a software through a PC.

SETUP DIAGRAM FOR TEST

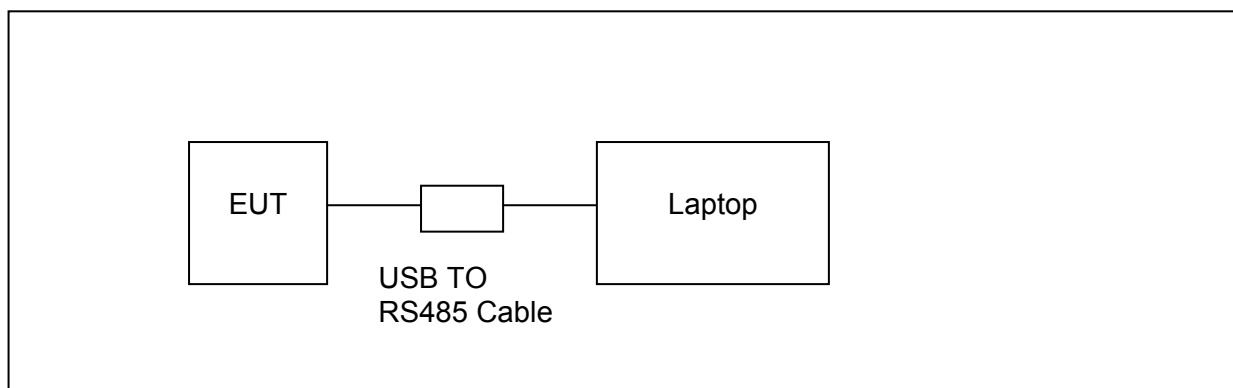



6. MEASURING INSTRUMENT AND SOFTWARE USED

Conducted Emissions							
Instrument							
Used	Equipment	Manufacturer	Model No.	Serial No.	Upper Last Cal.	Last Cal.	Next Cal.
<input checked="" type="checkbox"/>	EMI Test Receiver	R&S	ESR3	101961	Dec.20, 2016	Dec.12, 2017	Dec.11, 2018
<input checked="" type="checkbox"/>	Two-Line V-Network	R&S	ENV216	101983	Dec.20, 2016	Dec.12, 2017	Dec.11, 2018
<input checked="" type="checkbox"/>	Artificial Mains Networks	Schwarzbeck	NSLK 8126	8126465	Feb.10, 2017	Dec.12, 2017	Dec.11, 2018
Software							
Used	Description	Manufacturer	Name	Version			
<input checked="" type="checkbox"/>	Test Software for Conducted disturbance	Farad	EZ-EMC	Ver. UL-3A1			
Radiated Emissions							
Instrument							
Used	Equipment	Manufacturer	Model No.	Serial No.	Upper Last Cal.	Last Cal.	Next Cal.
<input checked="" type="checkbox"/>	MXE EMI Receiver	KESIGHT	N9038A	MY5640003 6	Feb. 24, 2017	Dec.12, 2017	Dec.11, 2018
<input checked="" type="checkbox"/>	Hybrid Log Periodic Antenna	TDK	HLP-3003C	130960	Jan.09, 2016	Jan.09, 2016	Jan.09, 2019
<input checked="" type="checkbox"/>	Preamplifier	HP	8447D	2944A09099	Feb. 13, 2017	Dec.12, 2017	Dec.11, 2018
<input checked="" type="checkbox"/>	EMI Measurement Receiver	R&S	ESR26	101377	Dec. 20, 2016	Dec.12, 2017	Dec.11, 2018
<input checked="" type="checkbox"/>	Horn Antenna	TDK	HRN-0118	130939	Jan. 09, 2016	Jan. 09, 2016	Jan. 09, 2019
<input checked="" type="checkbox"/>	High Gain Horn Antenna	Schwarzbeck	BBHA-9170	691	Jan.06, 2016	Jan.06, 2016	Jan.06, 2019
<input checked="" type="checkbox"/>	Preamplifier	TDK	PA-02-0118	TRS-305-00066	Jan. 14, 2017	Dec.12, 2017	Dec.11, 2018
<input checked="" type="checkbox"/>	Preamplifier	TDK	PA-02-2	TRS-307-00003	Dec. 20, 2016	Dec.12, 2017	Dec.11, 2018
<input checked="" type="checkbox"/>	Loop antenna	Schwarzbeck	1519B	00008	Mar. 26, 2016	Mar. 26, 2016	Mar. 26, 2019
Software							
Used	Description	Manufacturer	Name	Version			
<input checked="" type="checkbox"/>	Test Software for Radiated disturbance	Farad	EZ-EMC	Ver. UL-3A1			
Other instruments							
Used	Equipment	Manufacturer	Model No.	Serial No.	Upper Last Cal.	Last Cal.	Next Cal.
<input checked="" type="checkbox"/>	Spectrum Analyzer	Keysight	N9030A	MY5541051 2	Dec. 20, 2016	Dec.12, 2017	Dec.11, 2018
<input checked="" type="checkbox"/>	Power Meter	Keysight	N9031A	MY5541602 4	Feb. 13, 2017	Dec.12, 2017	Dec.11, 2018
<input checked="" type="checkbox"/>	Power Sensor	Keysight	N9323A	MY5544001 3	Feb. 13, 2017	Dec.12, 2017	Dec.11, 2018



7. MEASUREMENT METHODS

No.	Test Item	KDB Name	Section
1	6 dB Bandwidth	KDB 558074 D01 DTS Meas Guidance v05	8.0
2	Peak Output Power	KDB 558074 D01 DTS Meas Guidance v05	9.1.3
3	Power Spectral Density	KDB 558074 D01 DTS Meas Guidance v05	10.2
4	Out-of-band emissions in non-restricted bands	KDB 558074 D01 DTS Meas Guidance v05	11.0
5	Out-of-band emissions in restricted bands	KDB 558074 D01 DTS Meas Guidance v05	12.1
6	Band-edge	KDB 558074 D01 DTS Meas Guidance v05	13.3.2
7	Conducted Emission Test For AC Power Port	ANSI C63.10-2013	6.2

8. ANTENNA PORT TEST RESULTS

8.1. ON TIME AND DUTY CYCLE

LIMITS

None; for reporting purposes only

PROCEDURE

KDB 558074 Zero-Span Spectrum Analyzer Method

TEST SETUP

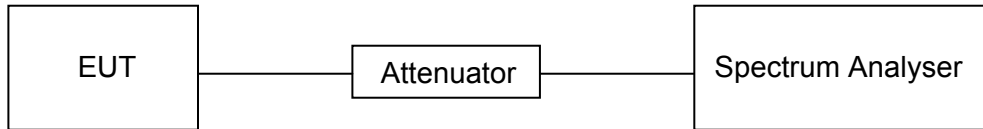

RESULTS

Mode	On Time (sec)	Period (sec)	Duty Cycle x (Linear)	Duty Cycle (%)	Duty Cycle Correction Factor (db)
Lora	0.131	0.131	1	100	0

Note: Duty Cycle Correction Factor = $10\log(1/x)$.
Where: x is Duty Cycle(Linear)
Where: T is On Time (transmit duration)

ON TIME AND DUTY CYCLE MID CH

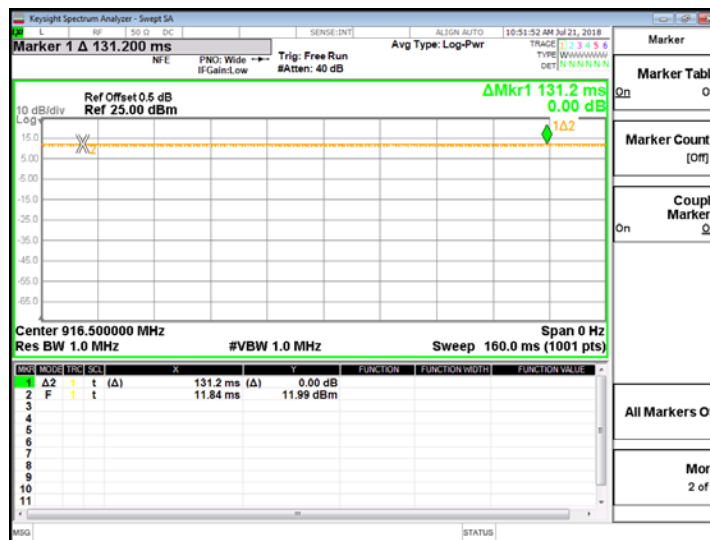

8.2. 6 dB DTS BANDWIDTH

LIMITS

FCC Part15 (15.247) Subpart C			
Section	Test Item	Limit	Frequency Range (MHz)
FCC 15.247(a)(2)f	6dB Bandwidth	$\geq 500\text{KHz}$	915.25-917.75

TEST PROCEDURE

Connect the UUT to the spectrum analyser and use the following settings:

Center Frequency	The center frequency of the channel under test
Detector	Peak
RBW	For 6 dB Bandwidth :100K
VBW	For 6dB Bandwidth : $\geq 3 \times \text{RBW}$
Trace	Max hold
Sweep	Auto couple

Allow the trace to stabilize and measure the maximum width of the emission that is constrained by the frequencies associated with the two outermost amplitude points (upper and lower frequencies) that are attenuated by 6 dB relative to the maximum level measured in the fundamental emission.

TEST SETUP

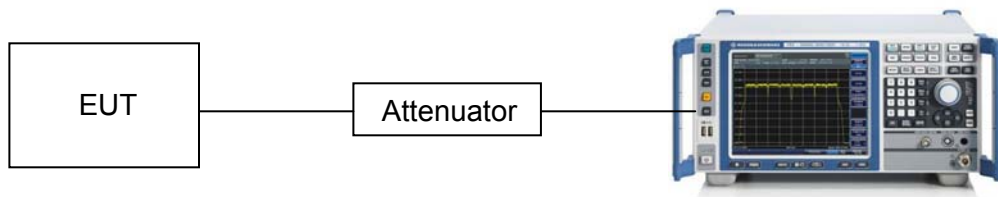



RESULTS

Channel	Frequency (MHz)	6dB bandwidth (MHz)	Limit (kHz)	Result
Low	915.25	0.692	500	Pass
Middle	916.50	0.692	500	Pass
High	917.75	0.690	500	Pass

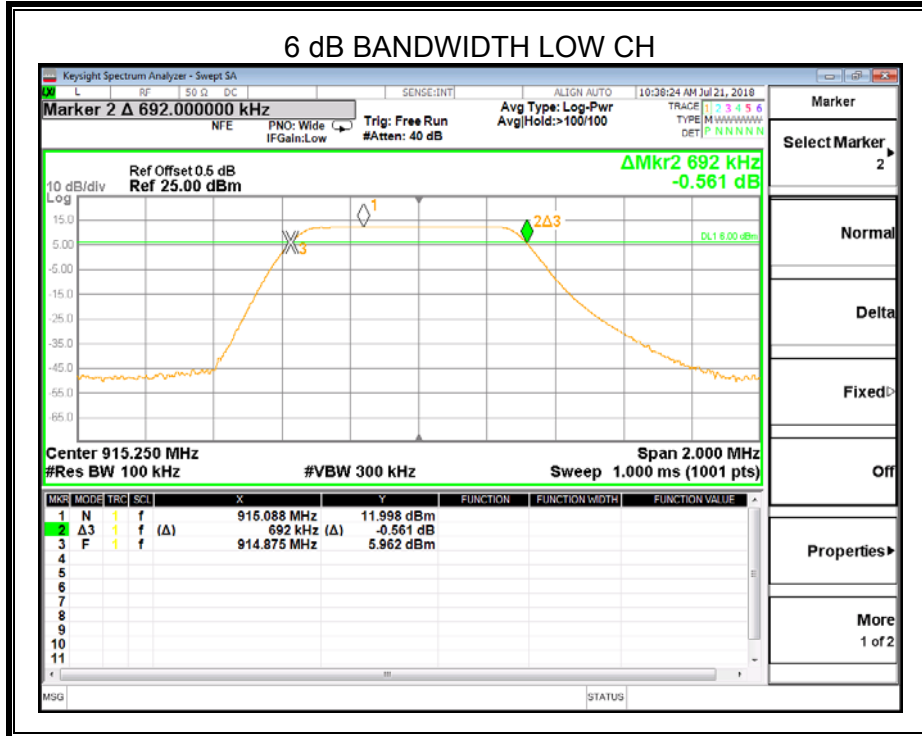

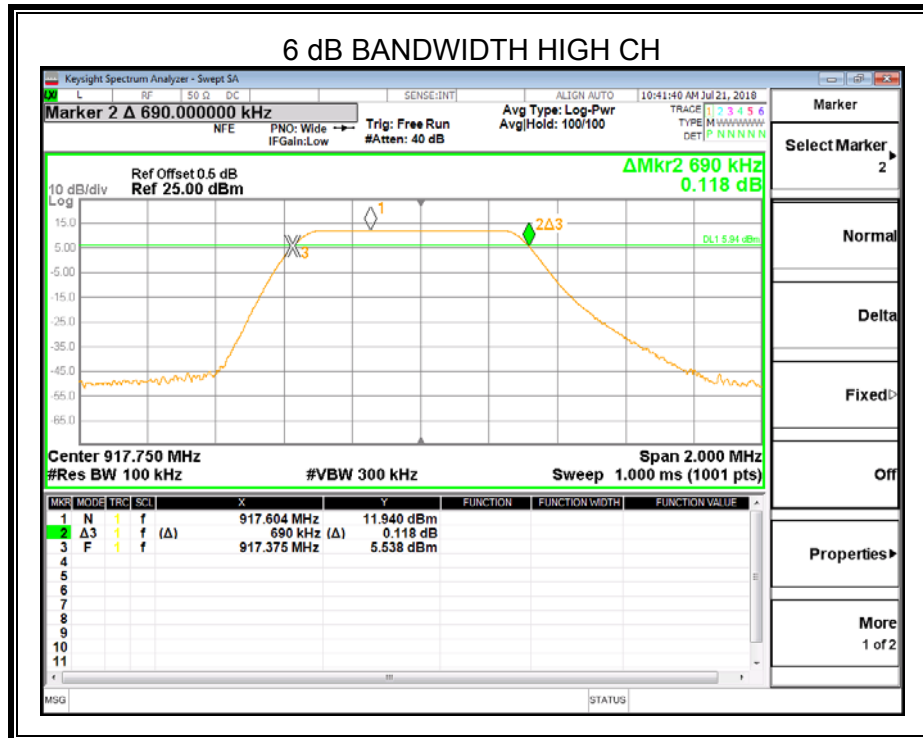
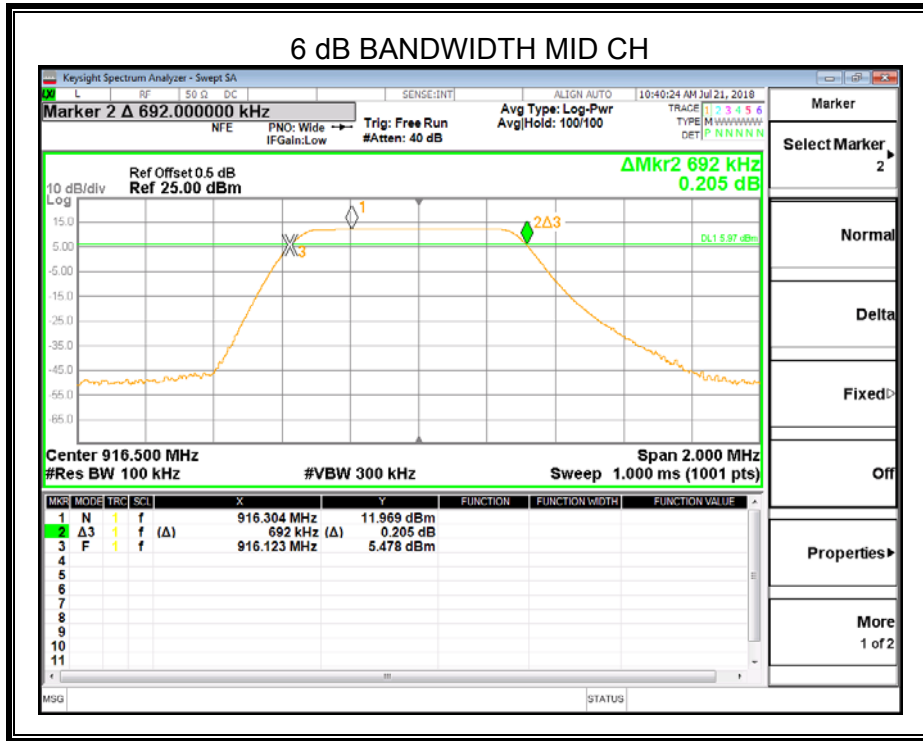

8.3. PEAK CONDUCTED OUTPUT POWER

LIMITS

FCC Part15 (15.247) Subpart C			
Section	Test Item	Limit	Frequency Range (MHz)
FCC 15.247(b)(3)	Peak Output Power	1 watt or 30dBm	915.25-917.75

TEST PROCEDURE

Place the EUT on the table and set it in the transmitting mode.
Remove the antenna from the EUT and then connect a low loss RF cable from the antenna port to the Power sensor.
Measure peak power each channel.

TEST SETUP

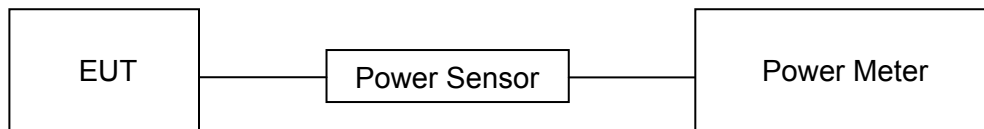



RESULTS

Test Channel	Frequency	Maximum Conducted Output Power(PK)	EIRP	LIMIT
	(MHz)	(dBm)	(dBm)	dBm
CH00	915.25	12.037	12.037	30
CH19	916.50	12.001	12.001	30
CH39	917.75	11.973	11.973	30

8.4. POWER SPECTRAL DENSITY

LIMITS

FCC Part15 (15.247) Subpart C			
Section	Test Item	Limit	Frequency Range (MHz)
FCC §15.247 (e)	Power Spectral Density	8 dBm in any 3 kHz band	915.25-917.75

TEST PROCEDURE

Connect the UUT to the spectrum analyser and use the following settings:

Center Frequency	The center frequency of the channel under test
Detector	Peak
RBW	$3 \text{ kHz} \leq \text{RBW} \leq 100 \text{ kHz}$
VBW	$\geq 3 \times \text{RBW}$
Span	1.5 x DTS bandwidth
Trace	Max hold
Sweep time	Auto couple.

Allow trace to fully stabilize and use the peak marker function to determine the maximum amplitude level within the RBW.

If measured value exceeds limit, reduce RBW (no less than 3 kHz) and repeat.

TEST SETUP

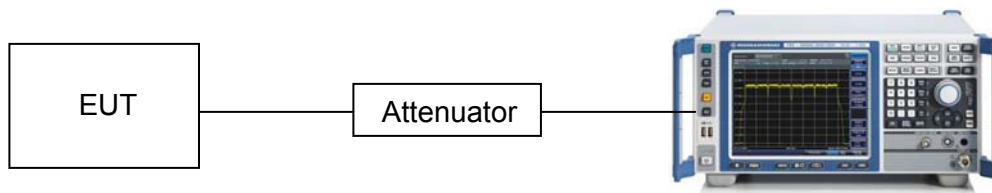



RESULTS

Frequency	Power Spectral Density (dBm/3kHz)	Limit (dBm/3kHz)	Result
915.25 MHz	-2.897	8	PASS
916.50 MHz	-2.919	8	PASS
917.75 MHz	-2.957	8	PASS

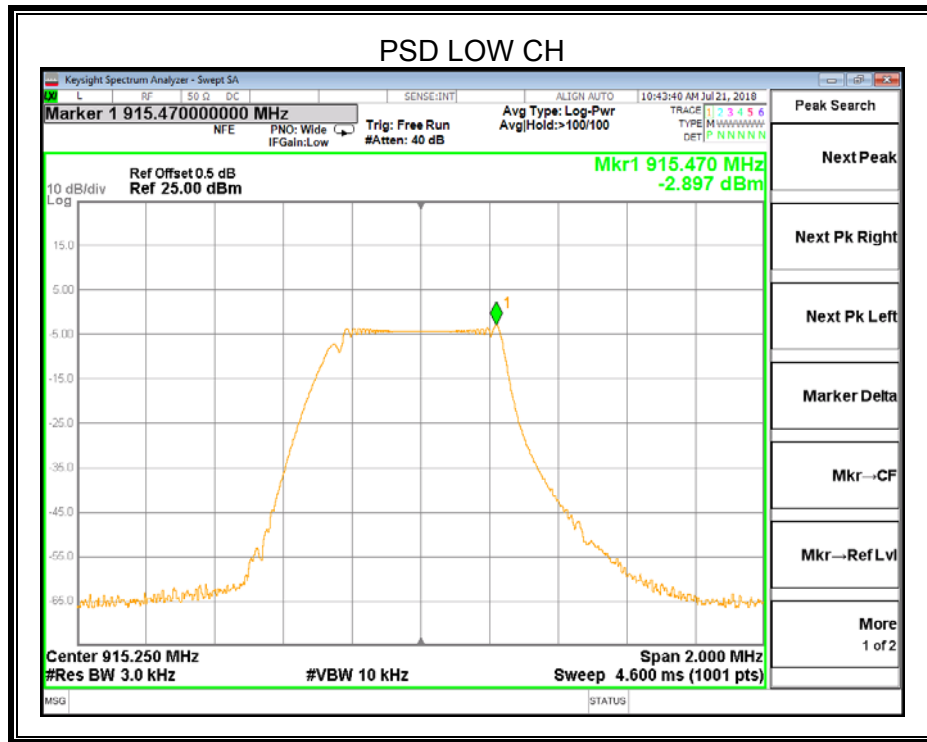

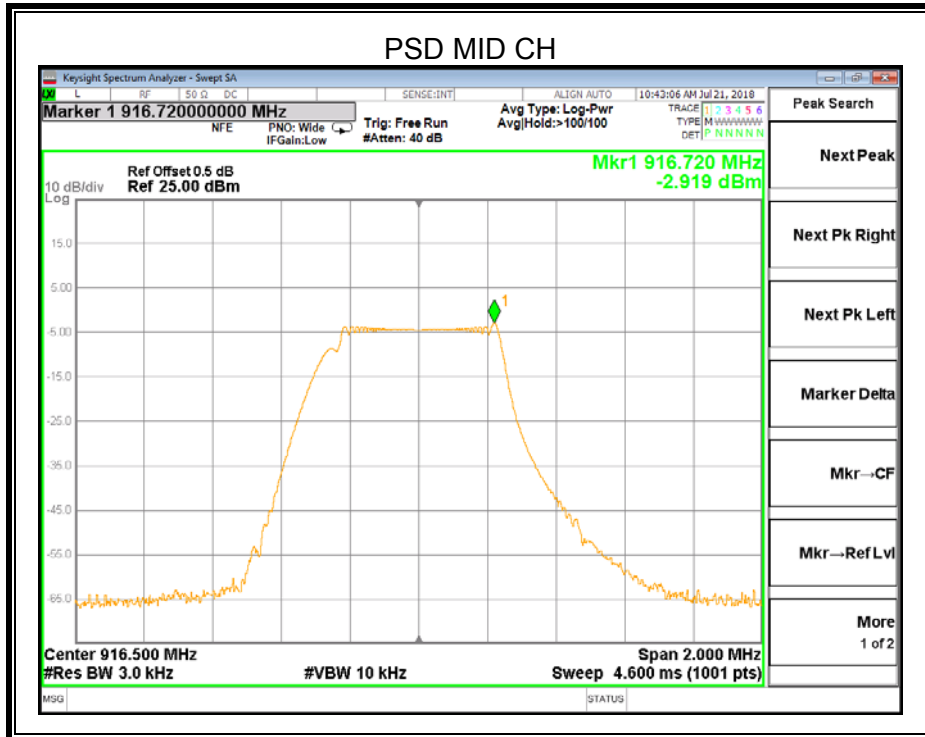

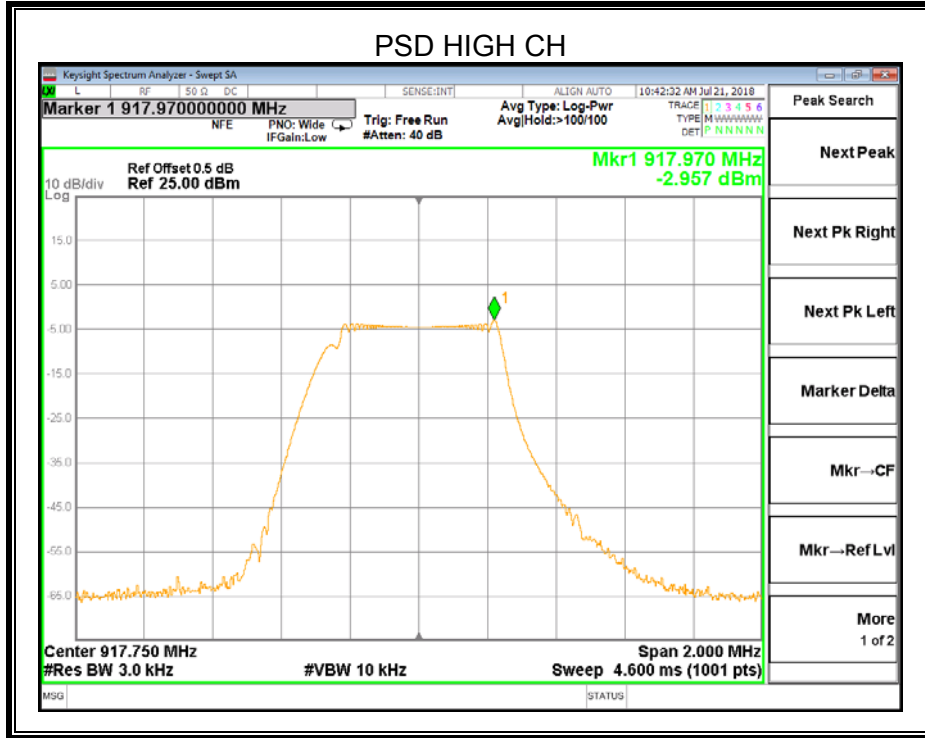

8.5. CONDUCTED BANDEGE AND SPURIOUS EMISSIONS

LIMITS

FCC Part15 (15.247) Subpart C		
Section	Test Item	Limit
FCC §15.247 (d)	Conducted Bandedge and Spurious Emissions	at least 20 dB below that in the 100 kHz bandwidth within the band that contains the highest level of the desired power

TEST PROCEDURE

Connect the UUT to the spectrum analyser and use the following settings:

Center Frequency	The center frequency of the channel under test
Detector	Peak
RBW	100KHz
VBW	$\geq 3 \times \text{RBW}$
Span	1.5 x DTS bandwidth
Trace	Max hold
Sweep time	Auto couple.

Use the peak marker function to determine the maximum PSD level.

Span	Set the center frequency and span to encompass frequency range to be measured
Detector	Peak
RBW	100KHz
VBW	$\geq 3 \times \text{RBW}$
measurement points	$\geq \text{span}/\text{RBW}$
Trace	Max hold
Sweep time	Auto couple.

Use the peak marker function to determine the maximum amplitude level.

TEST SETUP

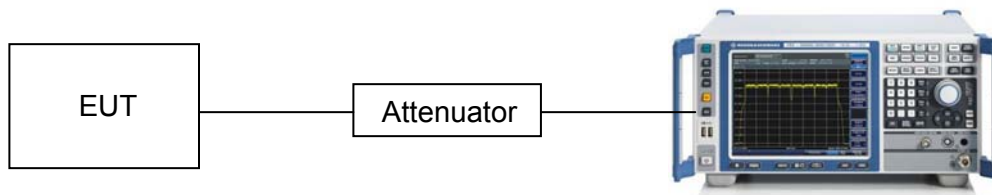



RESULTS

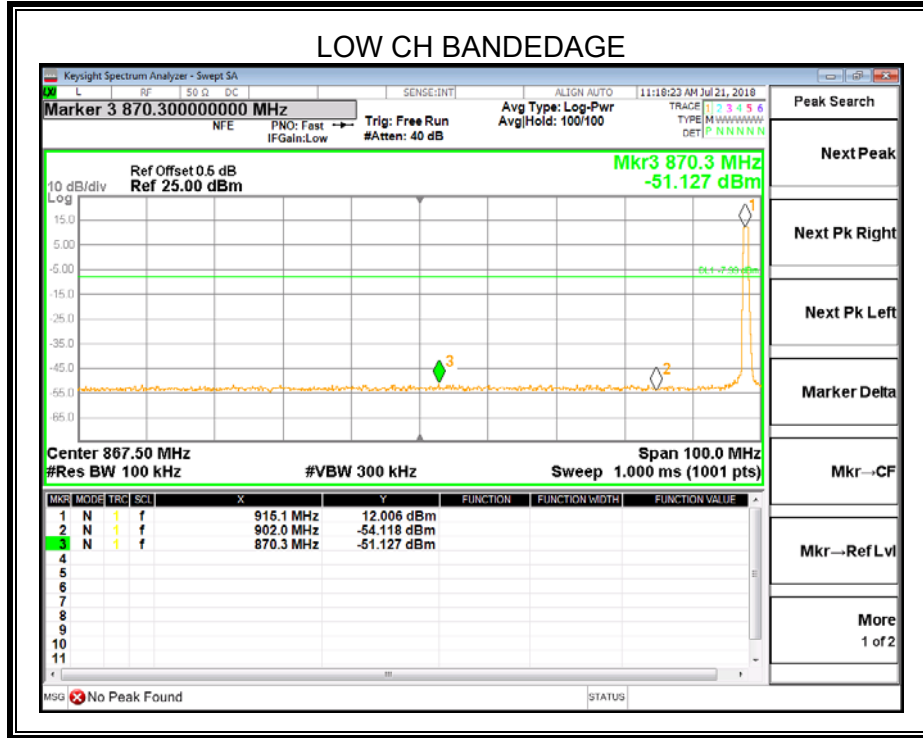

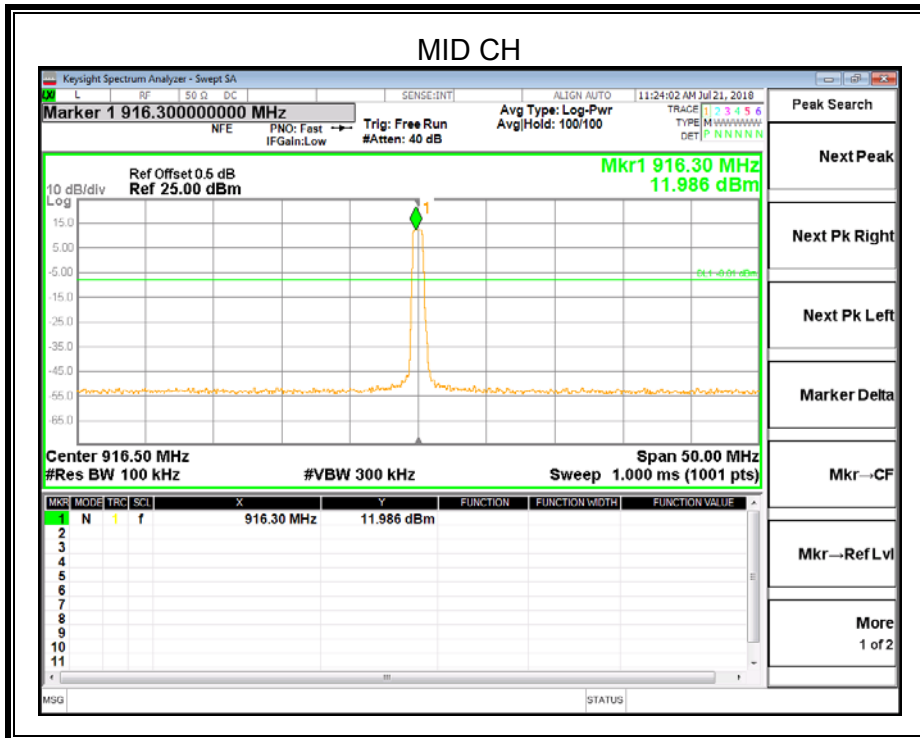
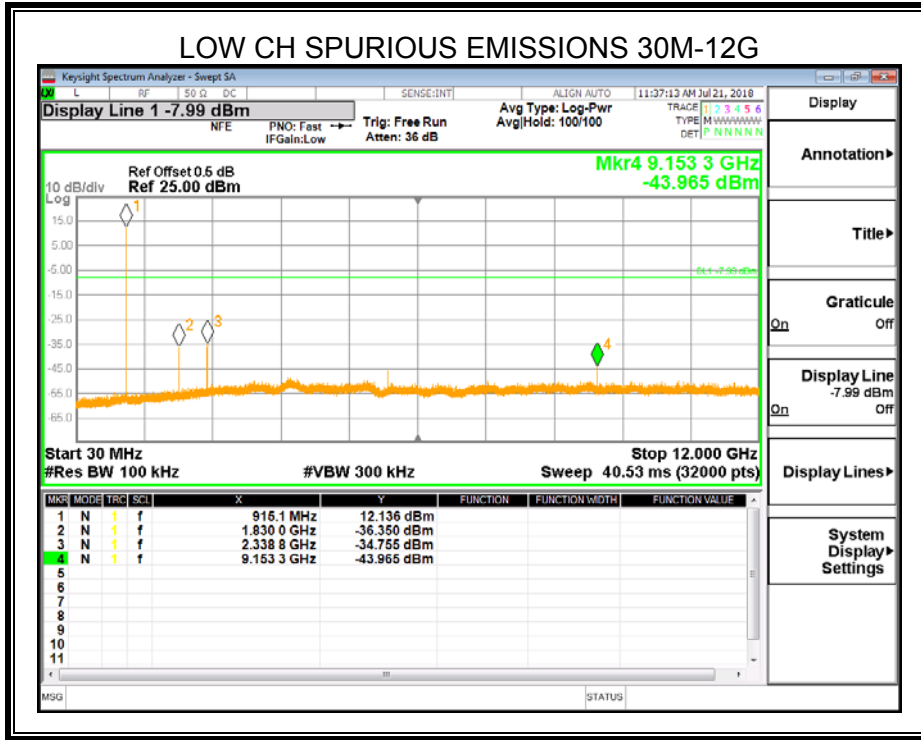

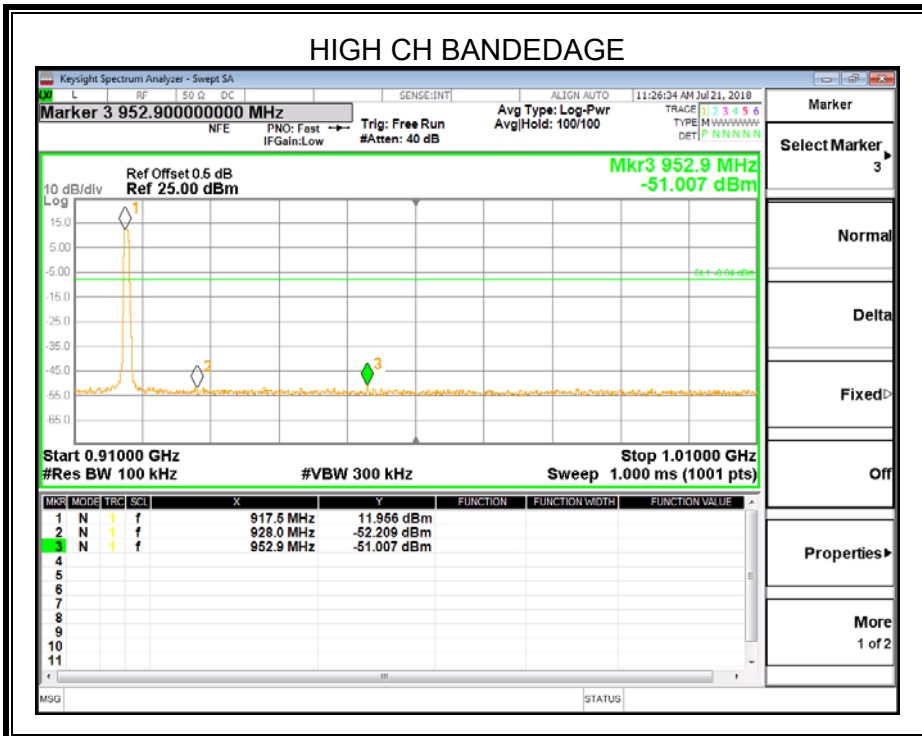
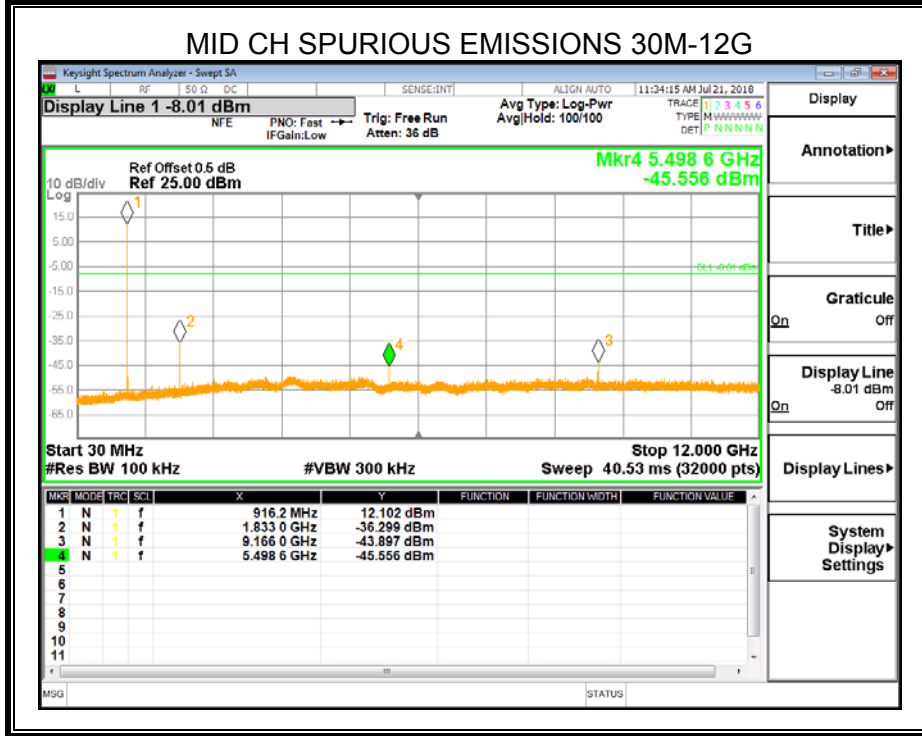

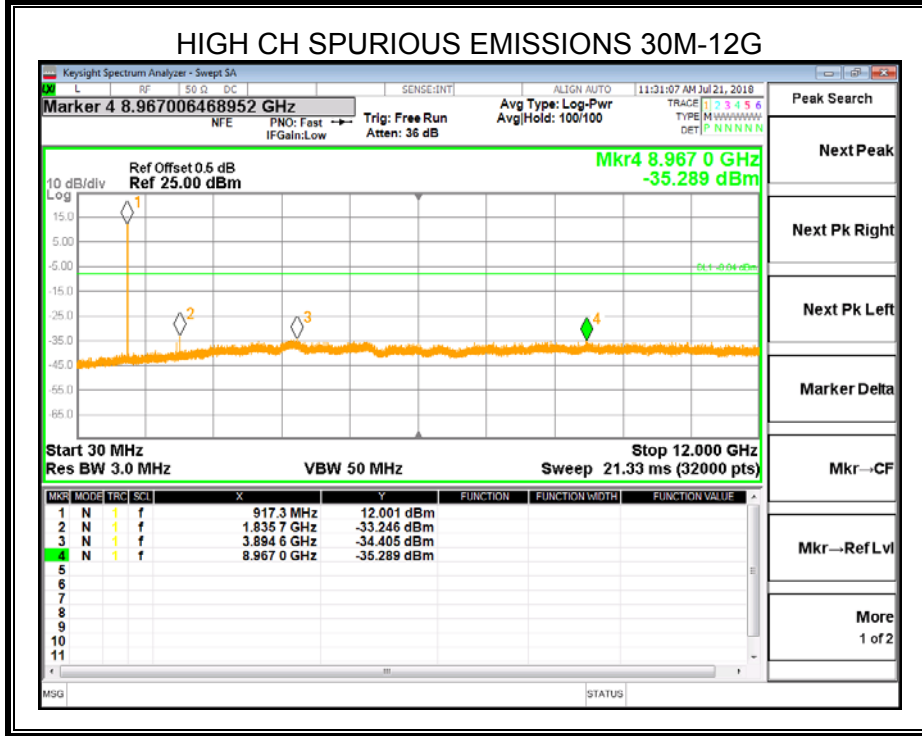



9. RADIATED TEST RESULTS

LIMITS

Please refer to FCC §15.205 and §15.209

Radiation Disturbance Test Limit for FCC (Class B)(9KHz-1GHz)

Frequency (MHz)	Field Strength (microvolts/meter)	Measurement Distance (meters)
0.009~0.490	2400/F(KHz)	300
0.490~1.705	24000/F(KHz)	30
1.705~30.0	30	30
30~88	100	3
88~216	150	3
216~960	200	3
960~1000	500	3

Note: 1) At frequencies at or above 30 MHz, measurements may be performed at a distance other than what is specified provided: measurements are not made in the near field except where it can be shown that near field measurements are appropriate due to the characteristics of the device; and it can be demonstrated that the signal levels needed to be measured at the distance employed can be detected by the measurement equipment. Measurements shall not be performed at a distance greater than 30 meters unless it can be further demonstrated that measurements at a distance of 30 meters or less are impractical. When performing measurements at a distance other than that specified, the results shall be extrapolated to the specified distance using an extrapolation factor of 20 dB/decade (inverse linear-distance for field strength measurements; inverse-linear-distance-squared for power density measurements).

(2) At frequencies below 30 MHz, measurements may be performed at a distance closer than that specified in the regulations; however, an attempt should be made to avoid making measurements in the near field. Pending the development of an appropriate measurement procedure for measurements performed below 30 MHz, when performing measurements at a closer distance than specified, the results shall be extrapolated to the specified distance by either making measurements at a minimum of two distances on at least one radial to determine the proper extrapolation factor or by using the square of an inverse linear distance extrapolation factor (40 dB/decade). This paragraph (f) shall not apply to Access BPL devices operating below 30 MHz.

Radiation Disturbance Test Limit for FCC (Above 1G)

Frequency (MHz)	dB(uV/m) (at 3 meters)	
	Peak	Average
Above 1000	74	54

Restricted bands of operation



MHz	MHz	MHz	GHz
0.090-0.110	16.42-16.423	399.9-410	4.5-5.15
¹ 0.495-0.505	16.69475-16.69525	608-614	5.35-5.46
2.1735-2.1905	16.80425-16.80475	960-1240	7.25-7.75
4.125-4.128	25.5-25.67	1300-1427	8.025-8.5
4.17725-4.17775	37.5-38.25	1435-1626.5	9.0-9.2
4.20725-4.20775	73-74.6	1645.5-1646.5	9.3-9.5
6.215-6.218	74.8-75.2	1660-1710	10.6-12.7
6.26775-6.26825	108-121.94	1718.8-1722.2	13.25-13.4
6.31175-6.31225	123-138	2200-2300	14.47-14.5
8.291-8.294	149.9-150.05	2310-2390	15.35-16.2
8.362-8.366	156.52475-156.52525	2483.5-2500	17.7-21.4
8.37625-8.38675	156.7-156.9	2690-2900	22.01-23.12
8.41425-8.41475	162.0125-167.17	3260-3267	23.6-24.0
12.29-12.293	167.72-173.2	3332-3339	31.2-31.8
12.51975-12.52025	240-285	3345.8-3358	36.43-36.5
12.57675-12.57725	322-335.4	3600-4400	(²)
13.36-13.41			

Note: ¹Until February 1, 1999, this restricted band shall be 0.490-0.510 MHz.

²Above 38.6c

TEST SETUP AND PROCEDURE

Below 30MHz

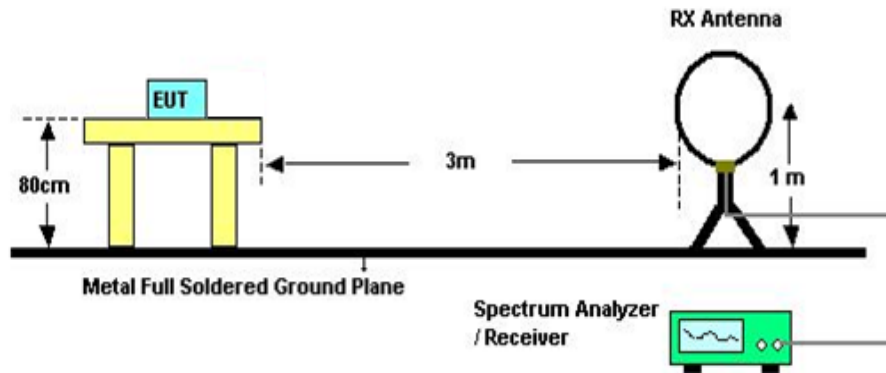

The setting of the spectrum analyser

RBW	200Hz (From 9kHz to 0.15MHz)/ 9KHz (From 0.15MHz to 30MHz)
VBW	200Hz (From 9kHz to 0.15MHz)/ 9KHz (From 0.15MHz to 30MHz)
Sweep	Auto
Trace	Max hold

1. The testing follows the guidelines in ANSI C63.10-2013
2. The EUT was arranged to its worst case and then turntable (from 0 degree to 360 degrees) to find the maximum reading. A pre-amp and a high pass filter are used for the test in order to get better signal level. Both horizontal and vertical polarizations of the antenna are set to make the measurement.
3. The EUT was placed on a turntable with 80cm above ground.
4. The EUT was set 3 meters from the interference receiving antenna, which was mounted on the top of a variable height antenna tower.
5. The radiated emission limits are based on measurements employing a CISPR quasi-peak detector except for the frequency bands 9-90 kHz, 110-490 kHz and above 1000 MHz. Radiated emission limits in these three bands are based on measurements employing an average detector.
6. For measurement below 1GHz, the initial step in collecting conducted emission data is a spectrum analyzer peak detector mode pre-scanning the measurement frequency range. Significant peaks are then marked and then Quasi Peak and average detector mode re-measured. If the emission level of the EUT measured by the peak detector is 3 dB lower than the applicable limit, the peak emission level will be reported. Otherwise, the emission measurement will be repeated using the quasi-peak and average detector and reported.
7. For the actual test configuration, please refer to the related item in this test report (Photographs of the Test Configuration)
8. Although these tests were performed other than open area test site, adequate comparison measurements were confirmed against 30m open area test site. Therefore sufficient tests were

made to demonstrate that the alternative site produces results that correlate with the ones of tests made in an open field based on KDB 414788.

Below 1G and above 30MHz

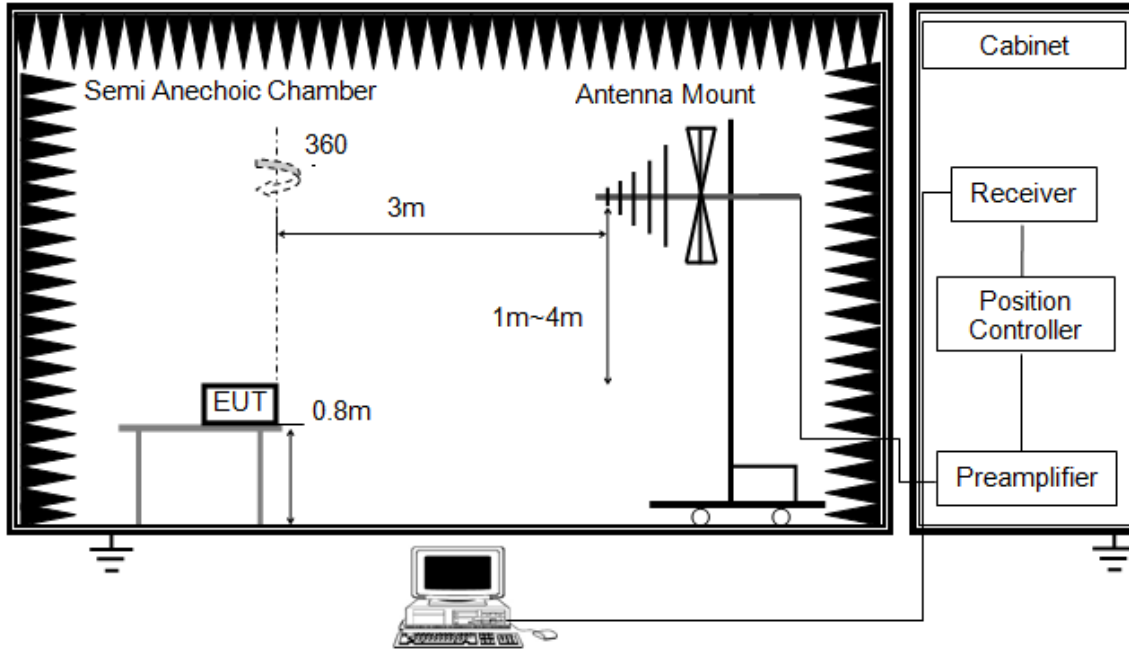

The setting of the spectrum analyser

RBW	120K
VBW	300K
Sweep	Auto
Detector	Peak/QP
Trace	Max hold

1. The testing follows the guidelines in ANSI C63.10-2013.
2. The EUT was arranged to its worst case and then tune the antenna tower (from 1 m to 4 m) and turntable (from 0 degree to 360 degrees) to find the maximum reading. A pre-amp and a high pass filter are used for the test in order to get better signal level. Both horizontal and vertical polarizations of the antenna are set to make the measurement.
3. The EUT was placed on a turntable with 80cm above ground.
4. The EUT was set 3 meters from the interference receiving antenna, which was mounted on the top of a variable height antenna tower.
5. For measurement below 1GHz, the initial step in collecting conducted emission data is a spectrum analyzer peak detector mode pre-scanning the measurement frequency range. Significant peaks are then marked and then Quasi Peak detector mode re-measured. If the emission level of the EUT measured by the peak detector is 3 dB lower than the applicable limit, the peak emission level will be reported. Otherwise, the emission measurement will be repeated using the quasi-peak detector and reported.

Above 1G

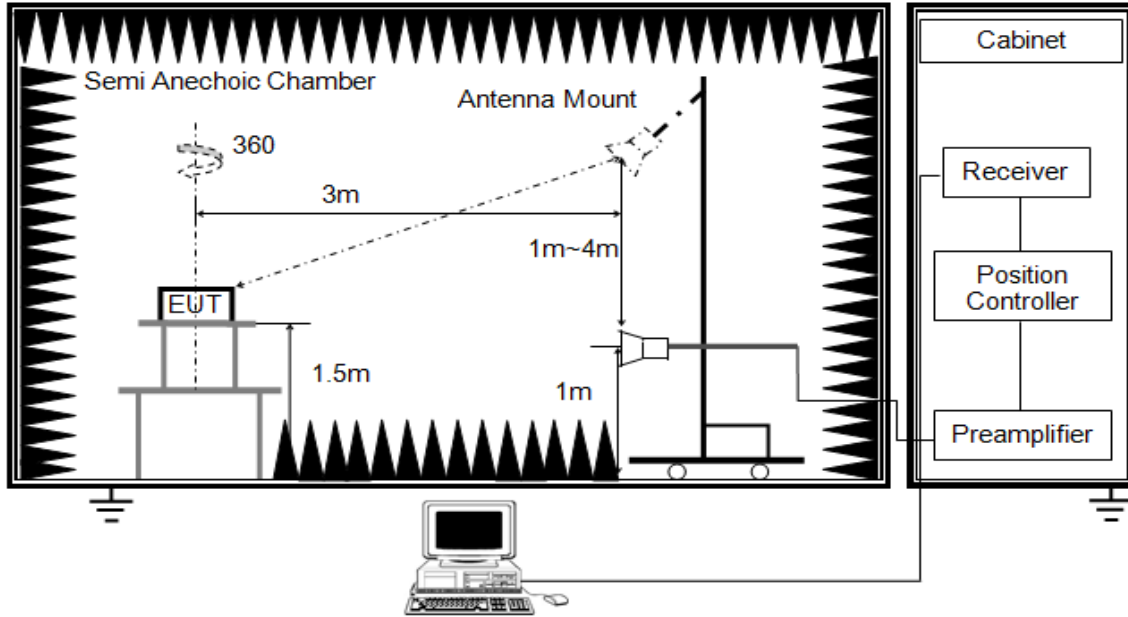

The setting of the spectrum analyser

RBW	1M
VBW	PEAK: 3M AVG: see note 6
Sweep	Auto
Detector	Peak
Trace	Max hold

1. The testing follows the guidelines in ANSI C63.10-2013.
2. The EUT was arranged to its worst case and then tune the antenna tower (1.5 m) and turntable (from 0 degree to 360 degrees) to find the maximum reading. A pre-amp and a high pass filter are used for the test in order to get better signal level. Both horizontal and vertical polarizations of the antenna are set to make the measurement.
3. The EUT was placed on a turntable with 80cm above ground.
4. The EUT was set 3 meters from the interference receiving antenna, which was mounted on the top of a variable height antenna tower.
5. For measurement above 1GHz, the emission measurement will be measured by the peak detector. This peak level, once corrected, must comply with the limit specified in Section 15.209.
6. For measurements above 1 GHz the resolution bandwidth is set to 1 MHz, then the video bandwidth is set to 3 MHz for peak measurements and 1 MHz resolution bandwidth with 1/T video bandwidth with peak detector. For the Duty Cycle and Correction Factor please refer to clause 7.1.ON TIME AND DUTY CYCLE.

X axis, Y axis, Z axis positions:

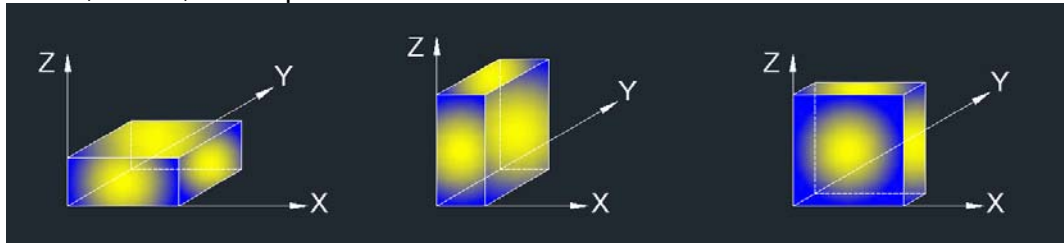

Note: For all radiated test, EUT in each of three orthogonal axis emissions had been tested, but only the worst case (Y axis) data recorded in the report.

9.1. RESTRICTED BANDEDGE

RESTRICTED BANDEDGE (LOW CHANNEL, HORIZONTAL)

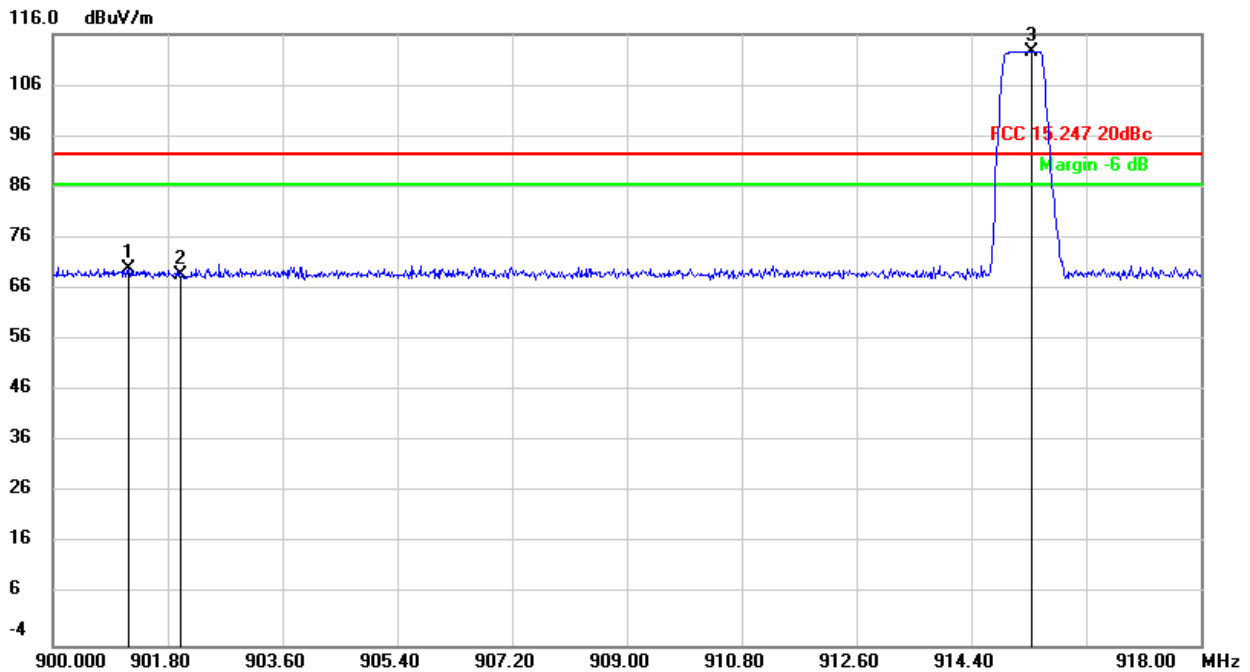

No.	Frequency (MHz)	Reading (dBuV)	Correct (dB/m)	Result (dBuV/m)	Limit (dBuV/m)	Margin (dB)	Remark
1	901.1879	44.75	25.10	69.85	92.59	-22.74	QP
2	902.0000	43.52	25.12	68.64	92.59	-23.95	QP

Note: 1. Measurement = Reading Level + Correct Factor.

2. Only the worst case emission will be recorder, if it complies with the limit, the other emissions deemed to comply with the limit.



RESTRICTED BANDEDGE (LOW CHANNEL, VERTICAL)

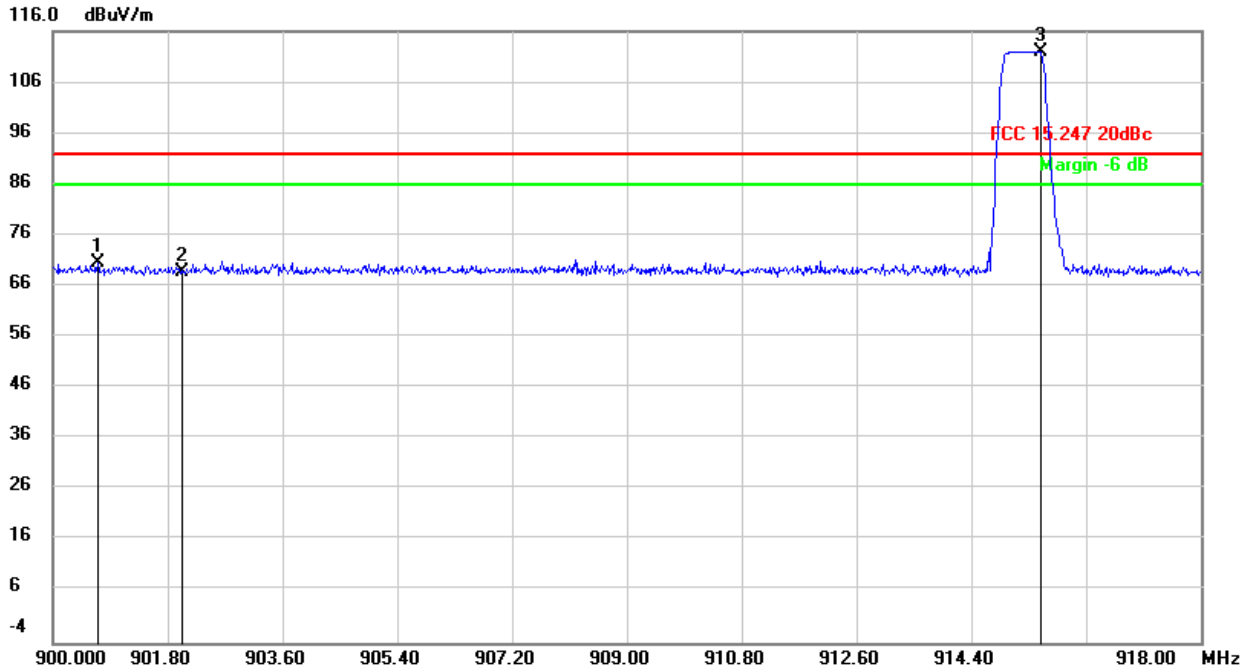

No.	Frequency (MHz)	Reading (dBuV)	Correct (dB/m)	Result (dBuV/m)	Limit (dBuV/m)	Margin (dB)	Remark
1	900.7020	45.37	25.10	70.47	91.95	-21.48	QP
2	902.0000	43.71	25.12	68.83	91.95	-23.12	QP

Note: 1. Measurement = Reading Level + Correct Factor.
 2. Only the worst case emission will be recorder, if it complies with the limit, the other emissions deemed to comply with the limit.



RESTRICTED BANDEDGE (HIGH CHANNEL, HORIZONTAL)

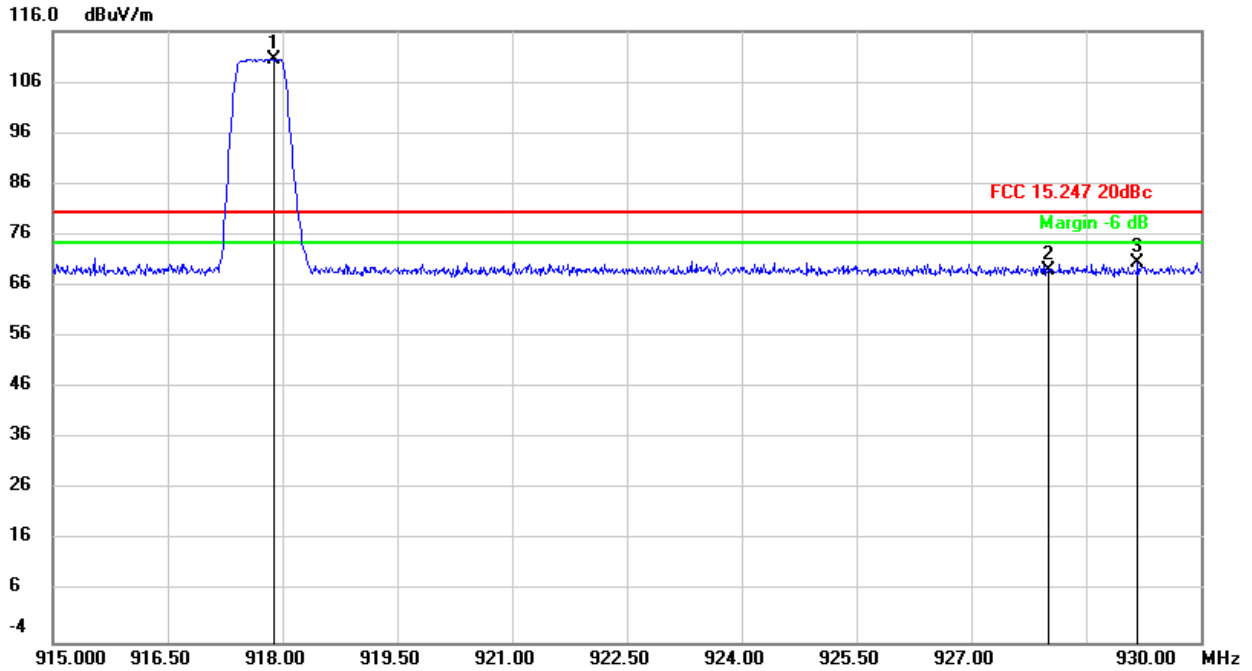

No.	Frequency (MHz)	Reading (dBuV)	Correct (dB/m)	Result (dBuV/m)	Limit (dBuV/m)	Margin (dB)	Remark
2	928.0000	43.95	25.21	69.16	80.47	-11.31	QP
3	929.1750	45.39	25.22	70.61	80.47	-9.86	QP

Note: 1. Measurement = Reading Level + Correct Factor.
2. Only the worst case emission will be recorder, if it complies with the limit, the other emissions deemed to comply with the limit.



RESTRICTED BANDEDGE (HIGH CHANNEL, VERTICAL)

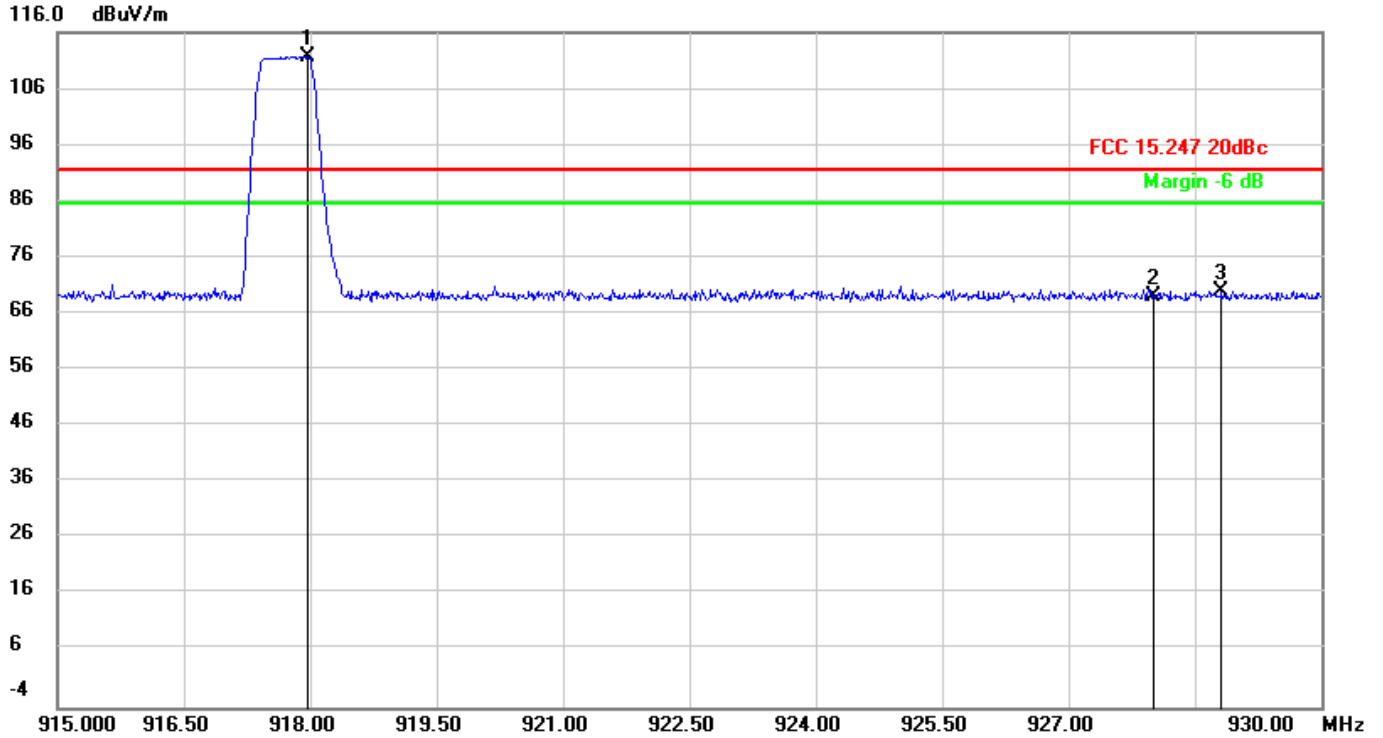

No.	Frequency (MHz)	Reading (dBuV)	Correct (dB/m)	Result (dBuV/m)	Limit (dBuV/m)	Margin (dB)	Remark
2	928.0000	43.92	25.21	69.13	91.56	-22.43	QP
3	928.8150	44.63	25.21	69.84	91.56	-21.72	QP

Note: 1. Measurement = Reading Level + Correct Factor.

2. Only the worst case emission will be recorder, if it complies with the limit, the other emissions deemed to comply with the limit.



9.2. SPURIOUS EMISSIONS (1~10GHz)

HARMONICS AND SPURIOUS EMISSIONS (LOW CHANNEL, HORIZONTAL1-3GHz)

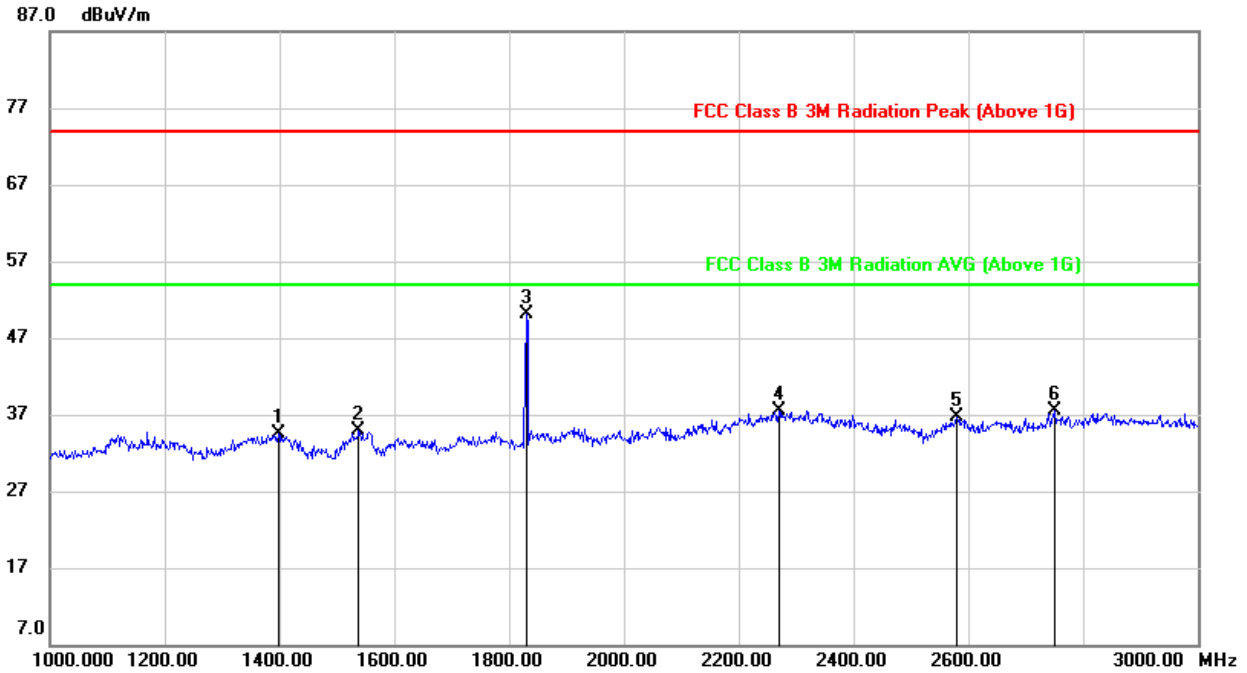

No.	Frequency (MHz)	Reading (dBuV)	Correct (dB/m)	Result (dBuV/m)	Limit (dBuV/m)	Margin (dB)	Remark
1	1398.000	46.57	-12.07	34.50	74.00	-39.50	peak
2	1538.000	47.19	-12.32	34.87	74.00	-39.13	peak
3	1830.000	61.17	-10.98	50.19	74.00	-23.81	peak
4	2270.000	45.03	-7.51	37.52	74.00	-36.48	peak
5	2580.000	44.94	-8.21	36.73	74.00	-37.27	peak
6	2750.000	44.74	-7.23	37.51	74.00	-36.49	peak

Note: 1. Peak Result = Reading Level + Correct Factor.
 2. If Peak Result complies with AV limit, AV Result is deemed to comply with AV limit.
 3. Peak: Peak detector.



HARMONICS AND SPURIOUS EMISSIONS (LOW CHANNEL, HORIZONTAL 3-10GHz)

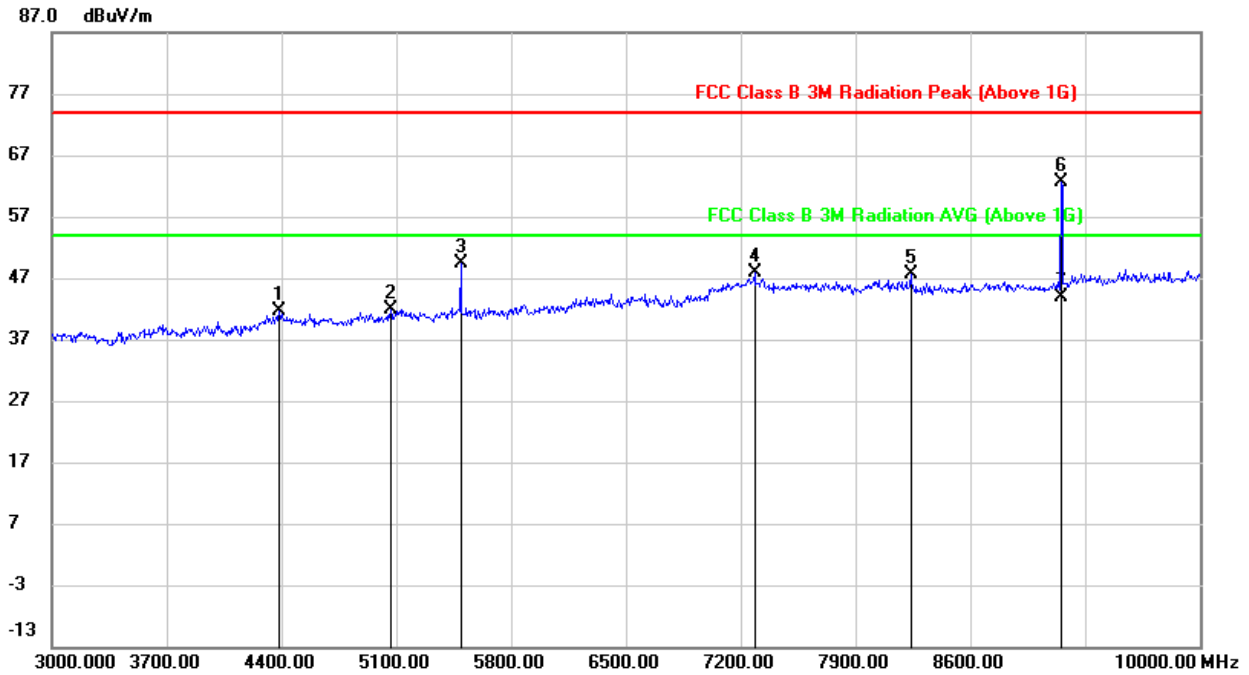

No.	Frequency (MHz)	Reading (dBuV)	Correct (dB/m)	Result (dBuV/m)	Limit (dBuV/m)	Margin (dB)	Remark
1	4386.000	42.50	-0.99	41.51	74.00	-32.49	peak
2	5065.000	41.07	0.85	41.92	74.00	-32.08	peak
3	5492.000	47.12	2.30	49.42	74.00	-24.58	peak
4	7284.000	40.00	7.85	47.85	74.00	-26.15	peak
5	8236.000	39.03	8.61	47.64	74.00	-26.36	peak
6	9153.539	52.75	9.89	62.64	74.00	-11.36	peak
7	9153.539	33.88	9.89	43.77	54.00	-10.23	AVG

- Note: 1. Peak Result = Reading Level + Correct Factor.
 2. If Peak Result complies with AV limit, AV Result is deemed to comply with AV limit.
 3. Peak: Peak detector.
 4. AVG: VBW=10Hz.
 5. For more information about the VBW of AVG, please refer to clause 7.1



HARMONICS AND SPURIOUS EMISSIONS (LOW CHANNEL, VERTICAL1-3GHz)

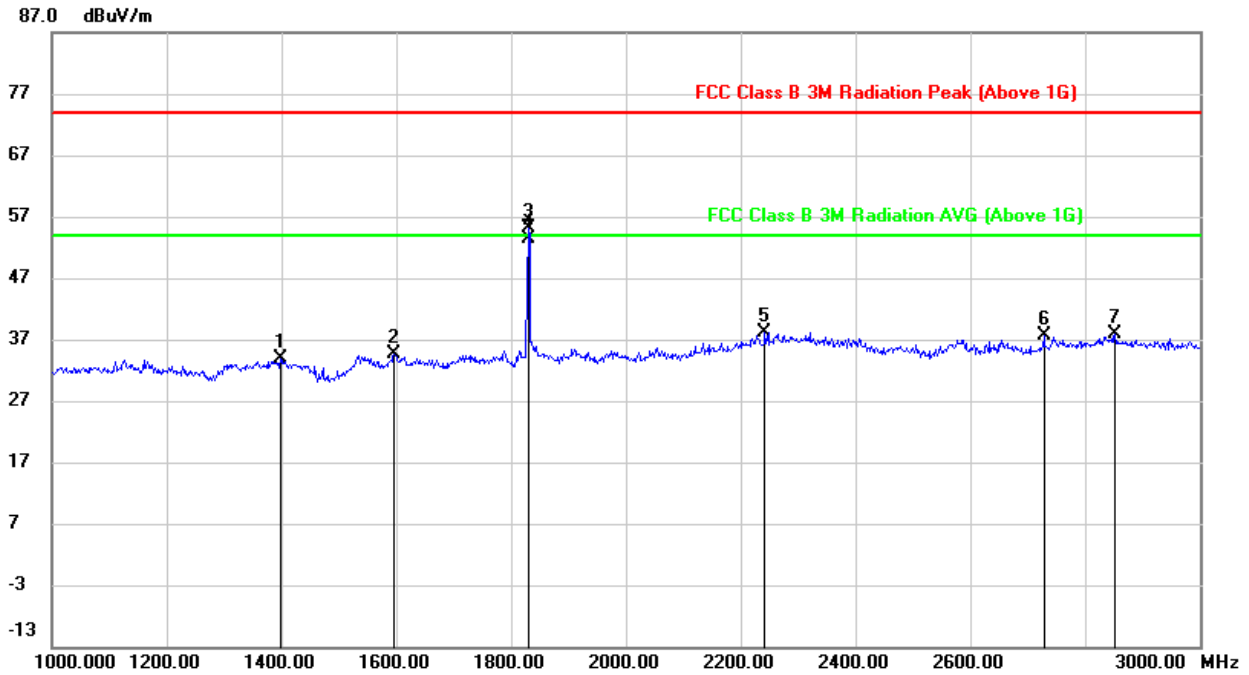

No.	Frequency (MHz)	Reading (dBuV)	Correct (dB/m)	Result (dBuV/m)	Limit (dBuV/m)	Margin (dB)	Remark
1	1398.000	46.21	-12.45	33.76	74.00	-40.24	peak
2	1596.000	46.65	-12.08	34.57	74.00	-39.43	peak
3	1830.000	66.00	-10.98	55.02	74.00	-18.98	peak
4	1830.000	64.24	-10.98	53.26	54.00	-0.74	AVG
5	2242.000	45.93	-7.70	38.23	74.00	-35.77	peak
6	2728.000	45.12	-7.45	37.67	74.00	-36.33	peak
7	2852.000	44.45	-6.68	37.77	74.00	-36.23	peak

- Note: 1. Peak Result = Reading Level + Correct Factor.
 2. If Peak Result complies with AV limit, AV Result is deemed to comply with AV limit.
 3. Peak: Peak detector.
 4. AVG: VBW=10Hz.
 5. For more information about the VBW of AVG, please refer to clause 7.1



HARMONICS AND SPURIOUS EMISSIONS (LOW CHANNEL, VERTICAL 3-10GHz)

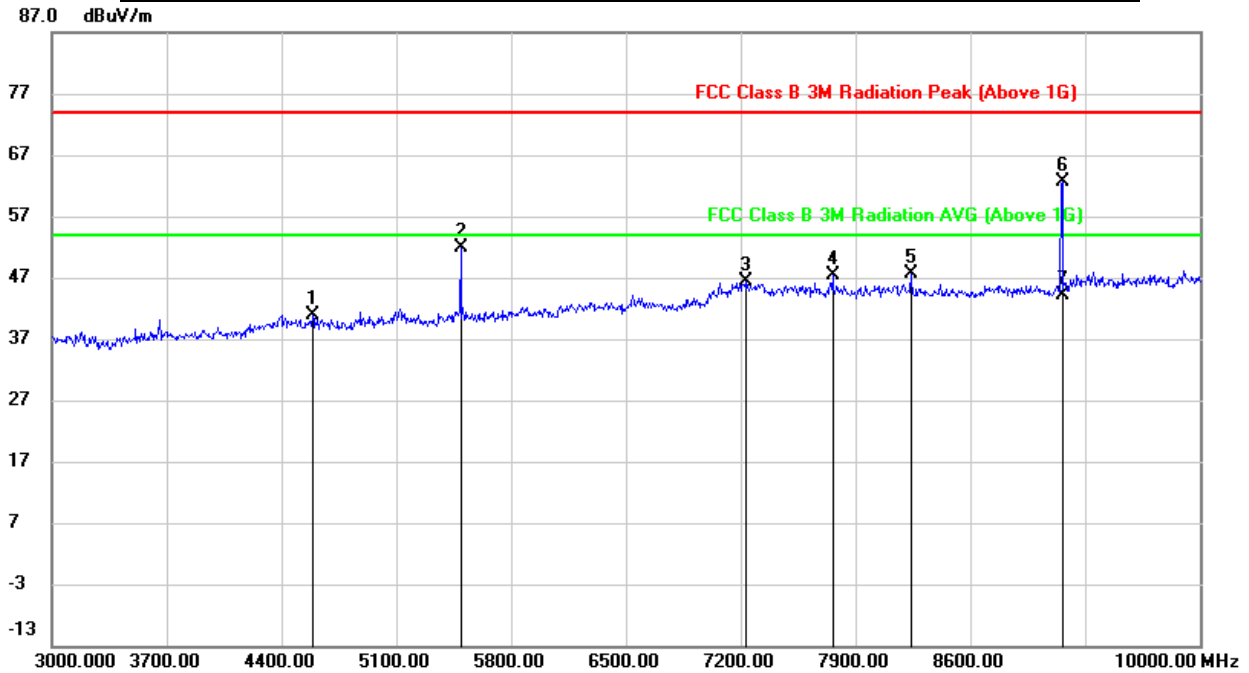

No.	Frequency (MHz)	Reading (dBuV)	Correct (dB/m)	Result (dBuV/m)	Limit (dBuV/m)	Margin (dB)	Remark
1	4589.000	41.45	-0.62	40.83	74.00	-33.17	peak
2	5492.000	49.51	2.30	51.81	74.00	-22.19	peak
3	7235.000	38.60	7.78	46.38	74.00	-27.62	peak
4	7760.000	38.99	8.28	47.27	74.00	-26.73	peak
5	8236.000	38.88	8.75	47.63	74.00	-26.37	peak
6	9155.105	52.63	10.00	62.63	74.00	-11.37	peak
7	9155.105	34.01	10.00	44.01	54.00	-9.99	AVG

- Note: 1. Peak Result = Reading Level + Correct Factor.
 2. If Peak Result complies with AV limit, AV Result is deemed to comply with AV limit.
 3. Peak: Peak detector.
 4. AVG: VBW=10Hz.
 5. For more information about the VBW of AVG, please refer to clause 7.1



HARMONICS AND SPURIOUS EMISSIONS (MID CHANNEL, HORIZONTAL1-3GHz)

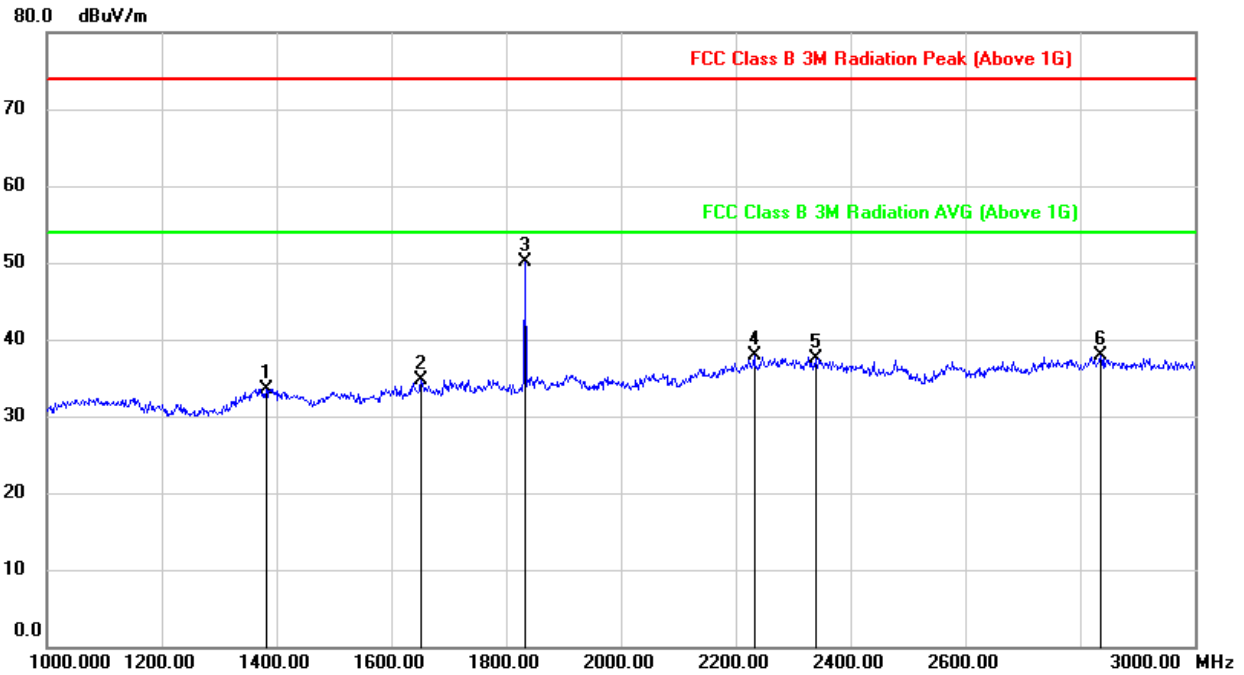

No.	Frequency (MHz)	Reading (dBuV)	Correct (dB/m)	Result (dBuV/m)	Limit (dBuV/m)	Margin (dB)	Remark
1	1382.000	45.66	-12.17	33.49	74.00	-40.51	peak
2	1652.000	46.43	-11.74	34.69	74.00	-39.31	peak
3	1832.000	61.11	-10.97	50.14	74.00	-23.86	peak
4	2232.000	45.81	-7.84	37.97	74.00	-36.03	peak
5	2340.000	45.09	-7.68	37.41	74.00	-36.59	peak
6	2836.000	44.63	-6.77	37.86	74.00	-36.14	peak

Note: 1. Peak Result = Reading Level + Correct Factor.
 2. If Peak Result complies with AV limit, AV Result is deemed to comply with AV limit.
 3. Peak: Peak detector.



HARMONICS AND SPURIOUS EMISSIONS (MID CHANNEL, HORIZONTAL 3-10GHz)

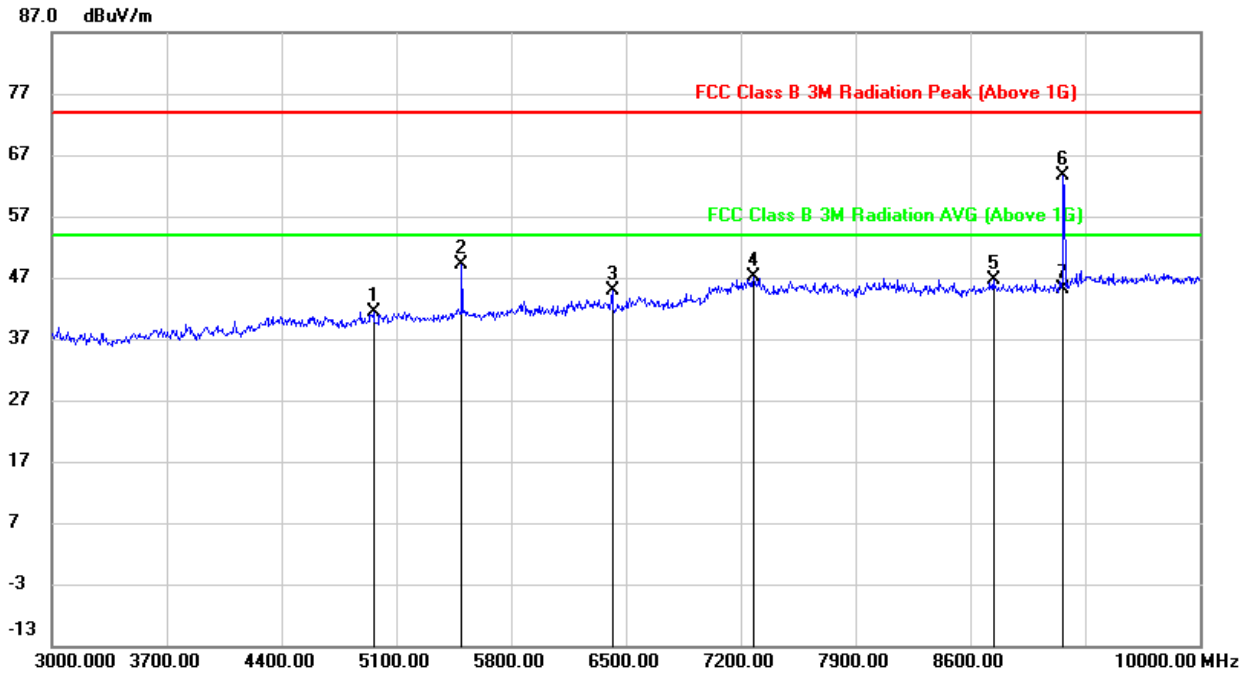

No.	Frequency (MHz)	Reading (dBuV)	Correct (dB/m)	Result (dBuV/m)	Limit (dBuV/m)	Margin (dB)	Remark
1	4960.000	40.79	0.56	41.35	74.00	-32.65	peak
2	5499.000	46.72	2.35	49.07	74.00	-24.93	peak
3	6416.000	40.20	4.67	44.87	74.00	-29.13	peak
4	7277.000	39.18	7.86	47.04	74.00	-26.96	peak
5	8740.000	37.32	9.37	46.69	74.00	-27.31	peak
6	9164.802	53.55	9.98	63.53	74.00	-10.47	peak
7	9164.802	35.13	9.98	45.11	54.00	-8.89	AVG

- Note:
1. Peak Result = Reading Level + Correct Factor.
 2. If Peak Result complies with AV limit, AV Result is deemed to comply with AV limit.
 3. Peak: Peak detector.
 4. AVG: VBW=10Hz.
 5. For more information about the VBW of AVG, please refer to clause 7.1



HARMONICS AND SPURIOUS EMISSIONS (MID CHANNEL, VERTICAL1-3GHz)

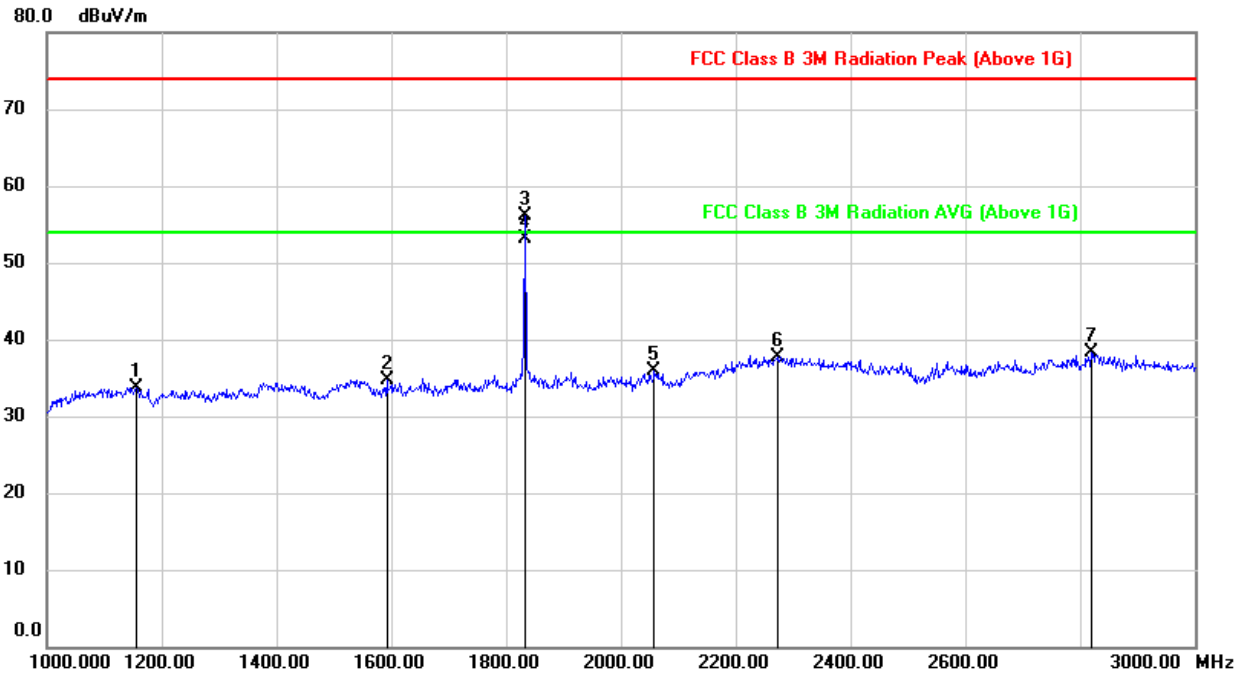

No.	Frequency (MHz)	Reading (dBuV)	Correct (dB/m)	Result (dBuV/m)	Limit (dBuV/m)	Margin (dB)	Remark
1	1156.000	47.28	-13.52	33.76	74.00	-40.24	peak
2	1592.000	46.78	-12.10	34.68	74.00	-39.32	peak
3	1834.000	67.06	-10.96	56.10	74.00	-17.90	peak
4	1834.000	64.13	-10.96	53.17	54.00	-0.83	AVG
5	2058.000	46.01	-10.20	35.81	74.00	-38.19	peak
6	2272.000	45.09	-7.42	37.67	74.00	-36.33	peak
7	2820.000	45.07	-6.85	38.22	74.00	-35.78	peak

- Note: 1. Peak Result = Reading Level + Correct Factor.
 2. If Peak Result complies with AV limit, AV Result is deemed to comply with AV limit.
 3. Peak: Peak detector.
 4. AVG: VBW=10Hz.
 5. For more information about the VBW of AVG, please refer to clause 7.1



HARMONICS AND SPURIOUS EMISSIONS (MID CHANNEL, VERTICAL 3-10GHz)

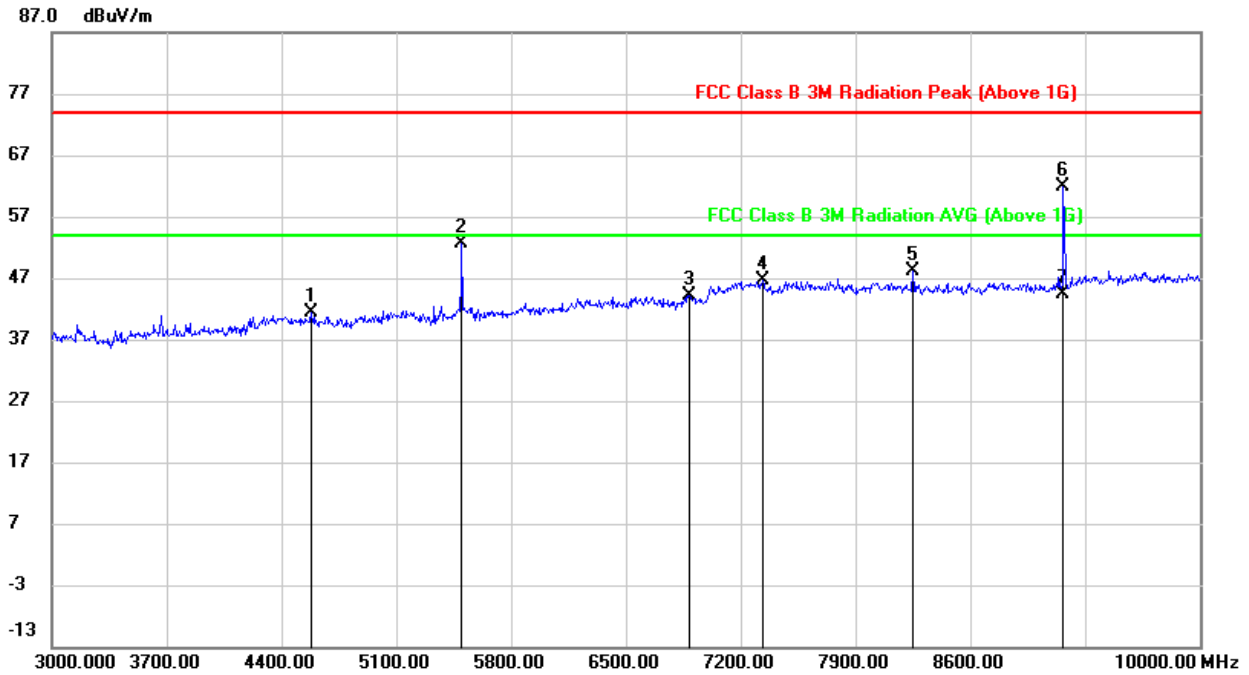

No.	Frequency (MHz)	Reading (dBuV)	Correct (dB/m)	Result (dBuV/m)	Limit (dBuV/m)	Margin (dB)	Remark
1	4582.000	41.89	-0.63	41.26	74.00	-32.74	peak
2	5499.000	50.39	2.35	52.74	74.00	-21.26	peak
3	6885.000	37.70	6.50	44.20	74.00	-29.80	peak
4	7333.000	39.05	7.53	46.58	74.00	-27.42	peak
5	8250.000	39.34	8.72	48.06	74.00	-25.94	peak
6	9167.000	51.88	10.05	61.93	74.00	-12.07	peak
7	9167.000	34.43	10.05	44.48	54.00	-9.52	AVG

- Note: 1. Peak Result = Reading Level + Correct Factor.
 2. If Peak Result complies with AV limit, AV Result is deemed to comply with AV limit.
 3. Peak: Peak detector.
 4. AVG: VBW=10Hz.
 5. For more information about the VBW of AVG, please refer to clause 7.1



HARMONICS AND SPURIOUS EMISSIONS (HIGH CHANNEL, HORIZONTAL1-3GHz)

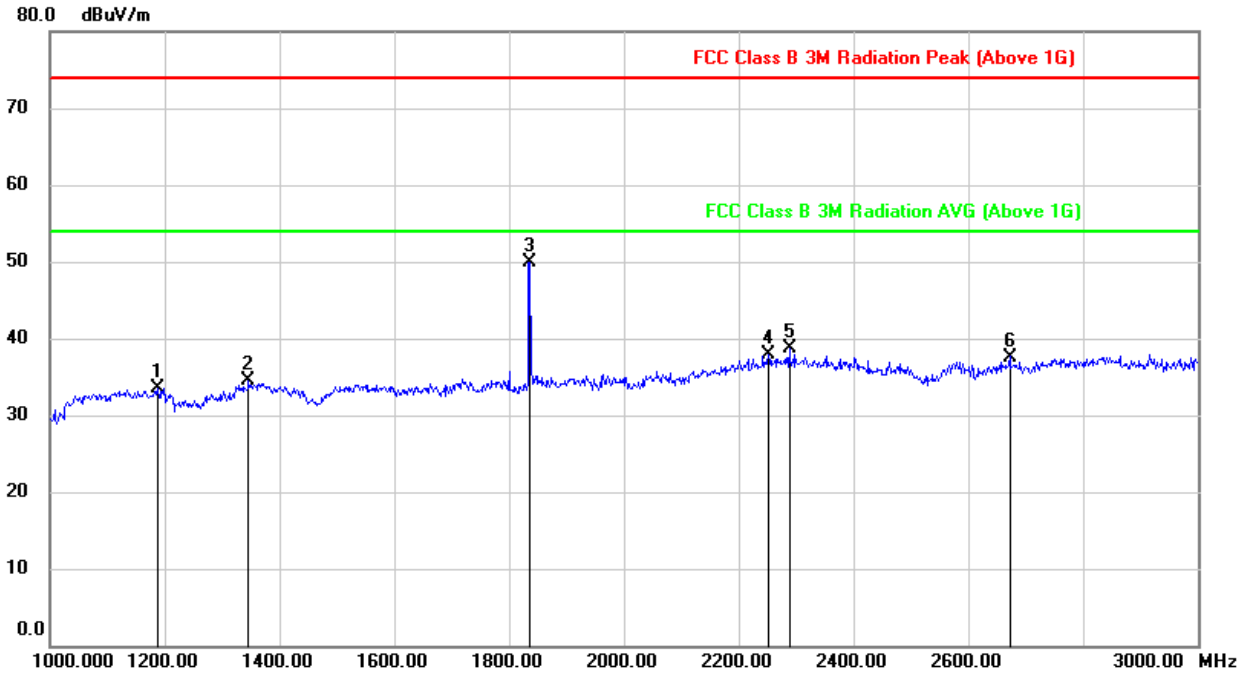

No.	Frequency (MHz)	Reading (dBuV)	Correct (dB/m)	Result (dBuV/m)	Limit (dBuV/m)	Margin (dB)	Remark
1	1188.000	46.67	-13.14	33.53	74.00	-40.47	peak
2	1346.000	46.93	-12.37	34.56	74.00	-39.44	peak
3	1836.000	60.94	-10.95	49.99	74.00	-24.01	peak
4	2252.000	45.39	-7.58	37.81	74.00	-36.19	peak
5	2288.000	46.15	-7.45	38.70	74.00	-35.30	peak
6	2672.000	45.34	-7.74	37.60	74.00	-36.40	peak

Note: 1. Peak Result = Reading Level + Correct Factor.
 2. If Peak Result complies with AV limit, AV Result is deemed to comply with AV limit.
 3. Peak: Peak detector.



HARMONICS AND SPURIOUS EMISSIONS (HIGH CHANNEL, HORIZONTAL 3-10GHz)

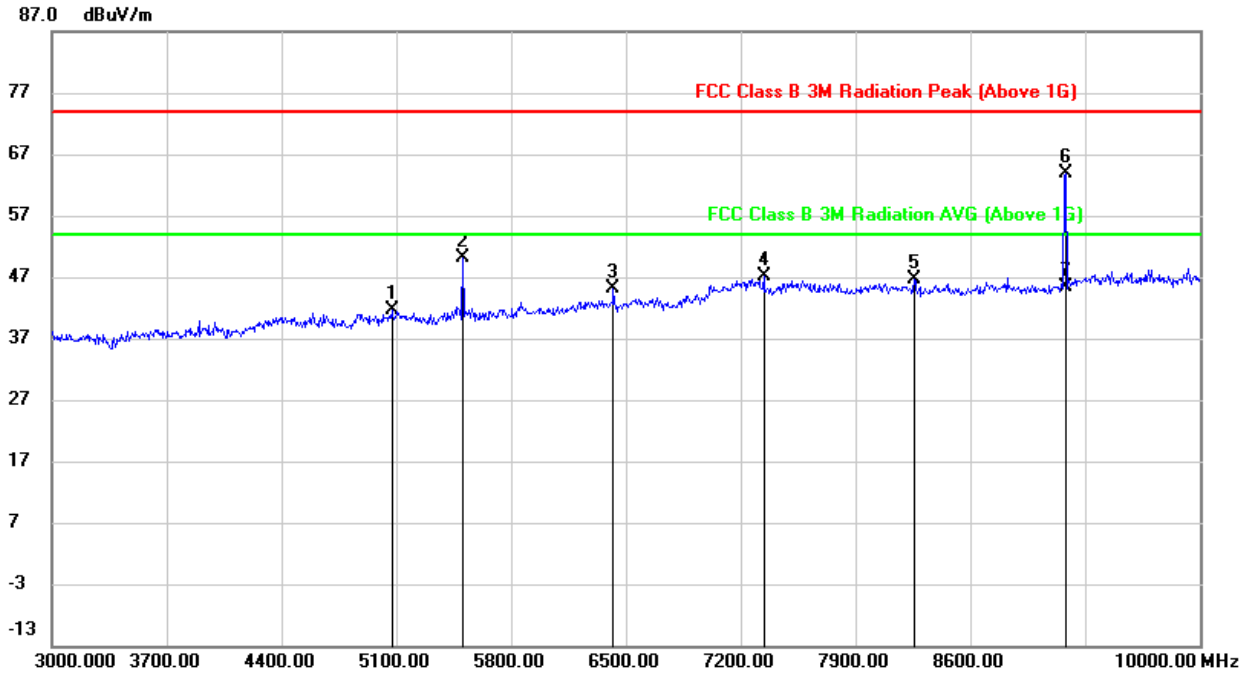

No.	Frequency (MHz)	Reading (dBuV)	Correct (dB/m)	Result (dBuV/m)	Limit (dBuV/m)	Margin (dB)	Remark
1	5072.000	40.69	0.88	41.57	74.00	-32.43	peak
2	5506.000	47.80	2.34	50.14	74.00	-23.86	peak
3	6423.000	40.35	4.67	45.02	74.00	-28.98	peak
4	7340.000	39.66	7.39	47.05	74.00	-26.95	peak
5	8257.000	38.06	8.50	46.56	74.00	-27.44	peak
6	9181.000	53.81	10.08	63.89	74.00	-10.11	peak
7	9181.000	35.24	10.08	45.32	54.00	-8.68	AVG

- Note: 1. Peak Result = Reading Level + Correct Factor.
 2. If Peak Result complies with AV limit, AV Result is deemed to comply with AV limit.
 3. Peak: Peak detector.
 4. AVG: VBW=10Hz.
 5. For more information about the VBW of AVG, please refer to clause 7.1



HARMONICS AND SPURIOUS EMISSIONS (HIGH CHANNEL, VERTICAL1-3GHz)

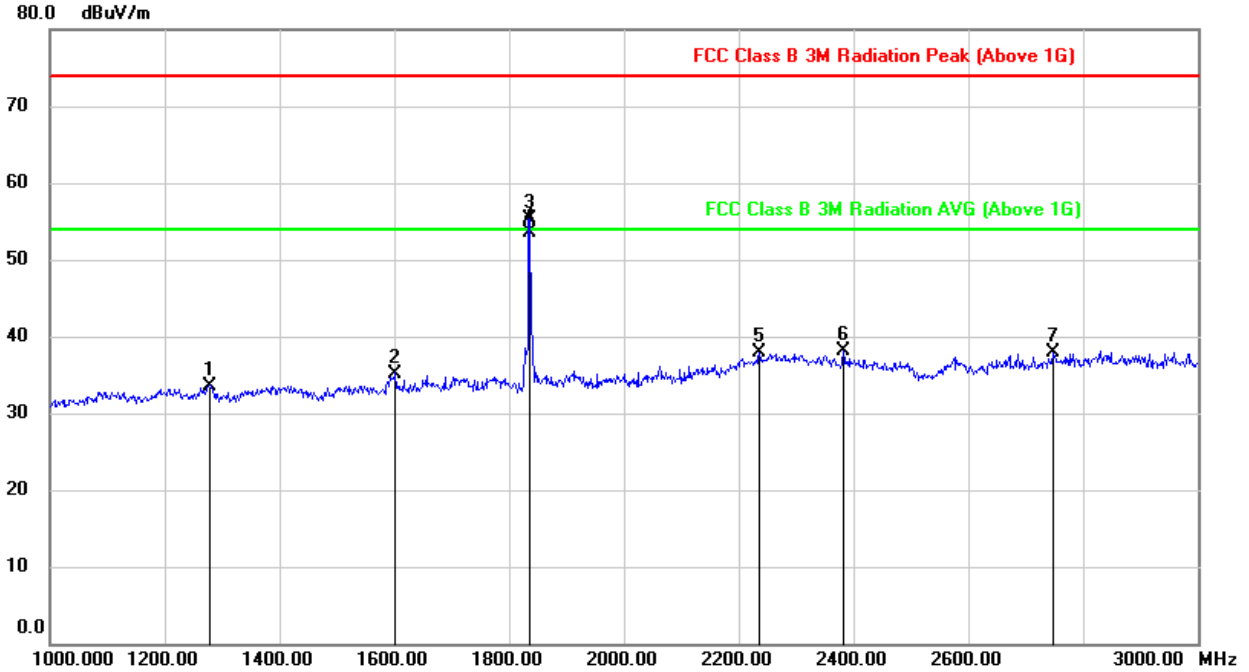

No.	Frequency (MHz)	Reading (dBuV)	Correct (dB/m)	Result (dBuV/m)	Limit (dBuV/m)	Margin (dB)	Remark
1	1278.000	46.31	-12.71	33.60	74.00	-40.40	peak
2	1602.000	47.24	-12.04	35.20	74.00	-38.80	peak
3	1836.000	66.29	-10.95	55.34	74.00	-18.66	peak
4	1836.000	64.41	-10.95	53.46	54.00	-0.54	AVG
5	2236.000	45.69	-7.79	37.90	74.00	-36.10	peak
6	2382.000	46.04	-7.88	38.16	74.00	-35.84	peak
7	2748.000	45.21	-7.35	37.86	74.00	-36.14	peak

Note: 1. Peak Result = Reading Level + Correct Factor.
 2. If Peak Result complies with AV limit, AV Result is deemed to comply with AV limit.
 3. Peak: Peak detector.



HARMONICS AND SPURIOUS EMISSIONS (HIGH CHANNEL, VERTICAL 3-10GHz)

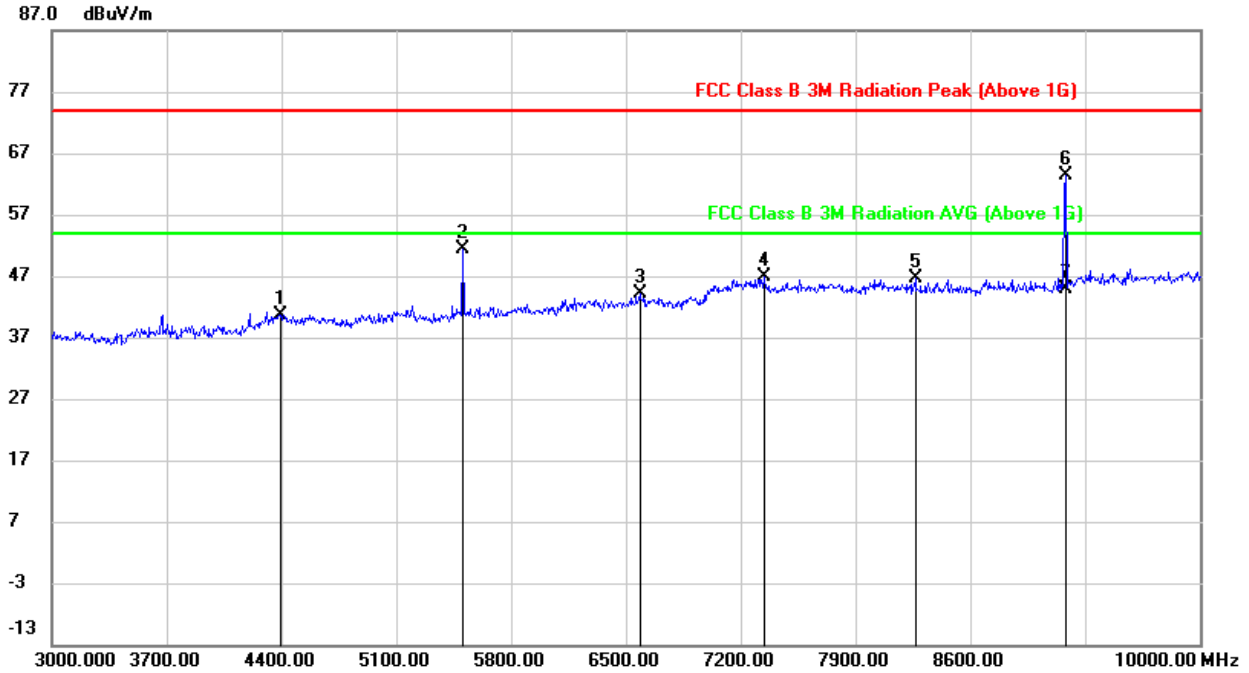

No.	Frequency (MHz)	Reading (dBuV)	Correct (dB/m)	Result (dBuV/m)	Limit (dBuV/m)	Margin (dB)	Remark
1	4393.000	41.55	-0.86	40.69	74.00	-33.31	peak
2	5506.000	49.15	2.34	51.49	74.00	-22.51	peak
3	6584.000	38.51	5.58	44.09	74.00	-29.91	peak
4	7340.000	39.43	7.47	46.90	74.00	-27.10	peak
5	8264.000	37.96	8.63	46.59	74.00	-27.41	peak
6	9178.043	53.17	10.11	63.28	74.00	-10.72	peak
7	9178.043	34.73	10.11	44.84	54.00	-9.16	AVG

- Note: 1. Peak Result = Reading Level + Correct Factor.
 2. If Peak Result complies with AV limit, AV Result is deemed to comply with AV limit.
 3. Peak: Peak detector.
 4. AVG: VBW=10Hz.
 5. For more information about the VBW of AVG, please refer to clause 7.1



9.3. SPURIOUS EMISSIONS 30M ~ 1 GHz

SPURIOUS EMISSIONS (MID CHANNEL, WORST-CASE CONFIGURATION, HORIZONTAL)

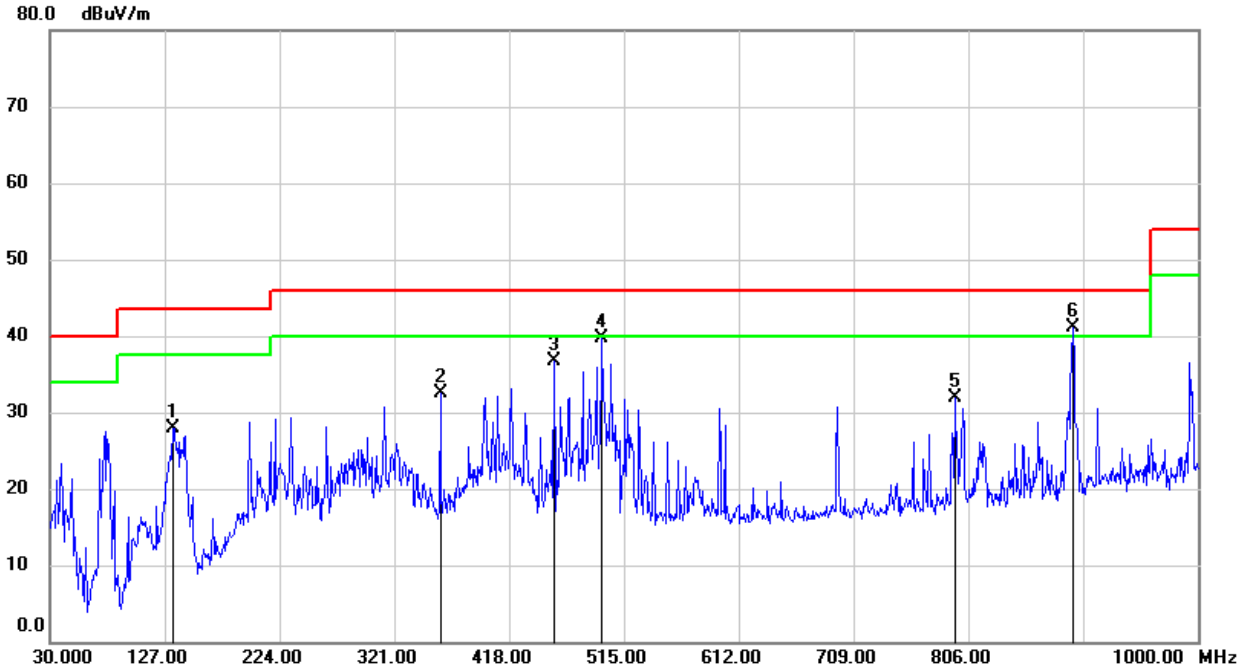

No.	Frequency (MHz)	Reading (dBuV)	Correct (dB/m)	Result (dBuV/m)	Limit (dBuV/m)	Margin (dB)	Remark
1	133.7899	46.41	-18.51	27.90	43.50	-15.60	QP
2	359.8000	45.96	-13.52	32.44	46.00	-13.56	QP
3	455.8300	48.32	-11.71	36.61	46.00	-9.39	QP
4	496.5700	50.89	-11.16	39.73	46.00	-6.27	QP
5	794.3600	39.02	-7.09	31.93	46.00	-14.07	QP
6	894.2700	46.57	-5.41	41.16	46.00	-4.84	QP

- Note: 1. Result Level = Read Level + Correct Factor.
 2. If Peak Result complies with QP limit, QP Result is deemed to comply with QP limit.
 3. Test setup: RBW: 120 kHz, VBW: 300 kHz, Sweep time: auto.



SPURIOUS EMISSIONS (MID CHANNEL, WORST-CASE CONFIGURATION, VERTICAL)

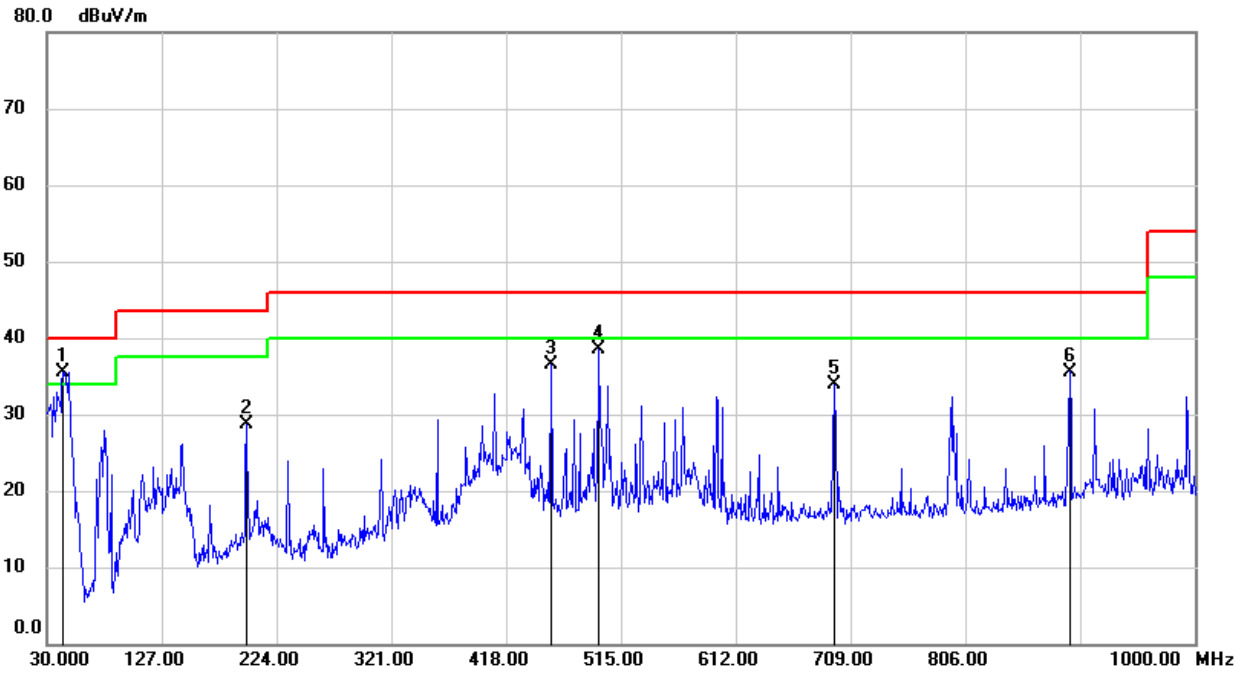

No.	Frequency (MHz)	Reading (dBuV)	Correct (dB/m)	Result (dBuV/m)	Limit (dBuV/m)	Margin (dB)	Remark
1	43.5800	55.73	-20.19	35.54	40.00	-4.46	QP
2	198.7800	43.61	-14.89	28.72	43.50	-14.78	QP
3	455.8300	48.12	-11.71	36.41	46.00	-9.59	QP
4	496.5700	49.73	-11.16	38.57	46.00	-7.43	QP
5	695.4200	41.82	-7.93	33.89	46.00	-12.11	QP
6	894.2700	41.01	-5.41	35.60	46.00	-10.40	QP

- Note: 1. Result Level = Read Level + Correct Factor.
 2. If Peak Result complies with QP limit, QP Result is deemed to comply with QP limit.
 3. Test setup: RBW: 120 kHz, VBW: 300 kHz, Sweep time: auto

Note: All the channels had been tested, but only the worst data recorded in the report.



9.4. SPURIOUS EMISSIONS BELOW 30M

SPURIOUS EMISSIONS (MID CHANNEL, WORST-CASE CONFIGURATION, HORIZONTAL)

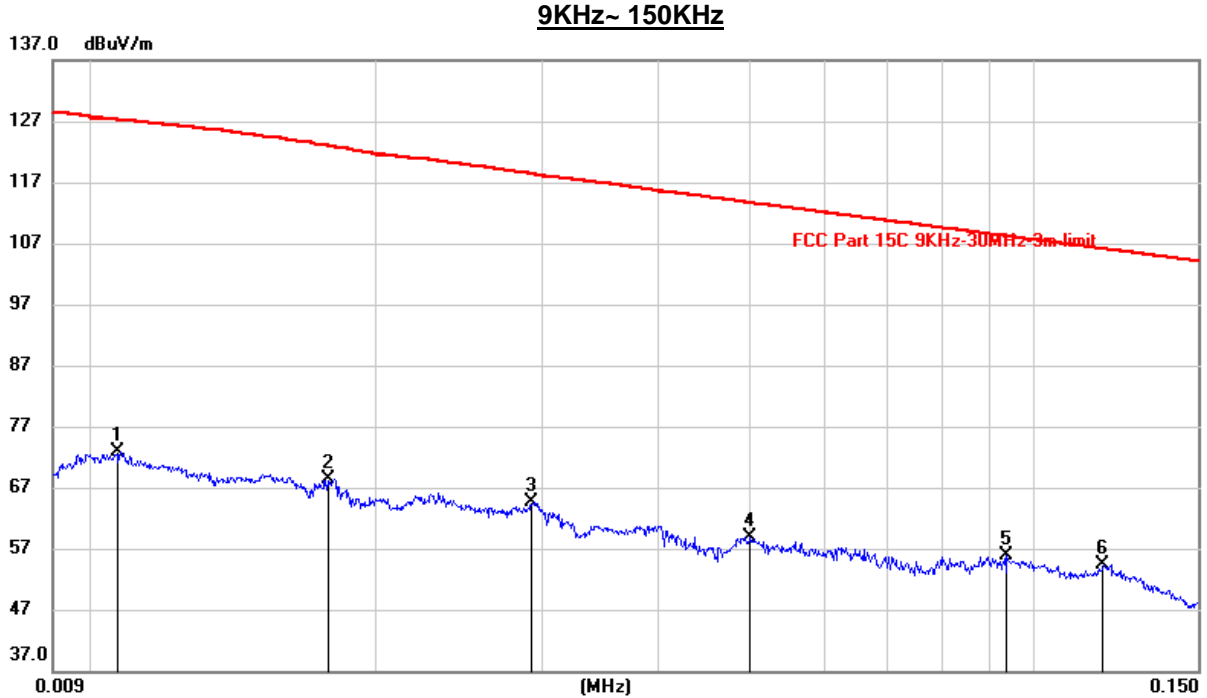

No.	Frequency (MHz)	Reading (dBuV)	Correct (dB/m)	Result (dBuV/m)	Limit (dBuV/m)	Margin (dB)	Remark
1	0.0106	52.54	20.22	72.76	127.24	-54.48	peak
2	0.0177	48.14	20.29	68.43	122.96	-54.53	peak
3	0.0292	44.23	20.31	64.54	118.34	-53.80	peak
4	0.0500	38.51	20.31	58.82	113.62	-54.80	peak
5	0.0937	35.68	20.24	55.92	108.18	-52.26	peak
6	0.1189	34.06	20.30	54.36	106.10	-51.74	peak

Note: 1. Measurement = Reading Level + Correct Factor.
 2. All the modes had been tested, but only the worst data were recorded in the report.
 3. If Peak Result complies with AV and QP limit, AV and QP Result are deemed to comply with AV limit.

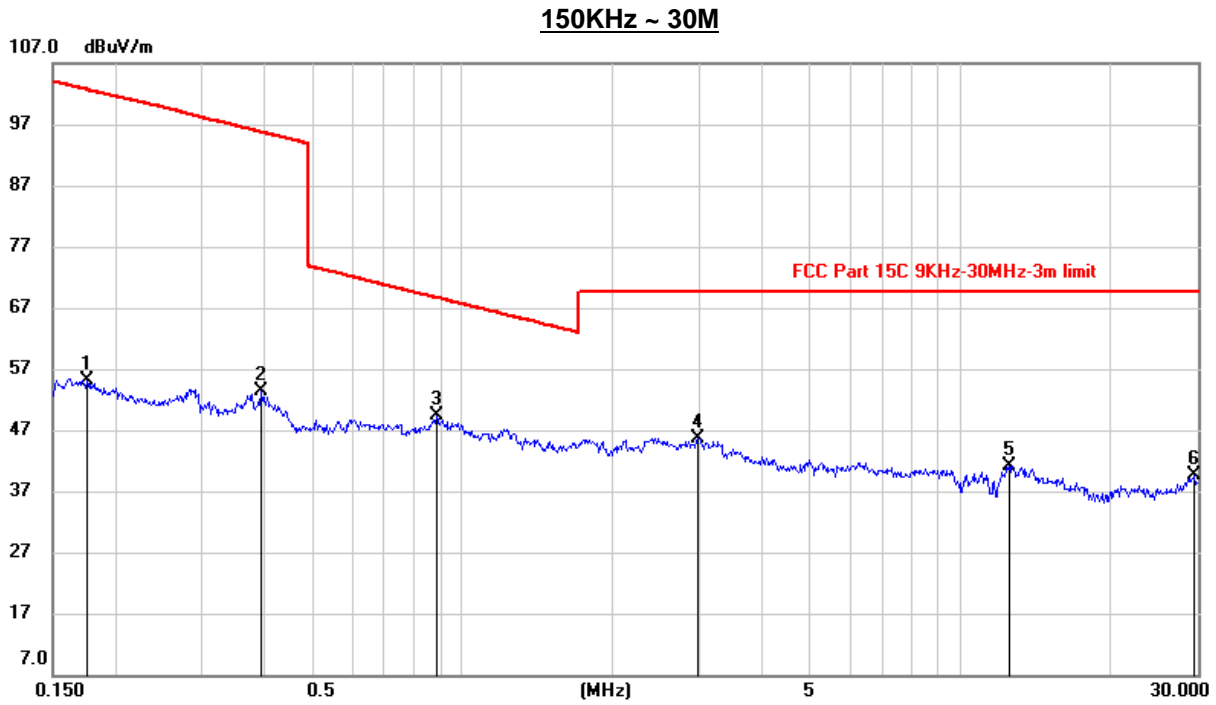

No.	Frequency (MHz)	Reading (dBuV)	Correct (dB/m)	Result (dBuV/m)	Limit (dBuV/m)	Margin (dB)	Remark
1	0.1766	34.85	20.39	55.24	102.67	-47.43	peak
2	0.3933	32.99	20.27	53.26	95.73	-42.47	peak
3	0.8891	29.00	20.36	49.36	68.63	-19.27	peak
4	2.9618	24.77	20.89	45.66	69.54	-23.88	peak
5	12.5820	20.19	21.00	41.19	69.54	-28.35	peak
6	29.5269	17.80	21.95	39.75	69.54	-29.79	peak

Note: 1. Measurement = Reading Level + Correct Factor.
 2. All the modes had been tested, but only the worst data were recorded in the report.
 3. If Peak Result complies with AV and QP limit, AV and QP Result are deemed to comply with AV limit.



SPURIOUS EMISSIONS (MID CHANNEL, WORST-CASE CONFIGURATION, VERTICAL)

9KHz~ 150KHz

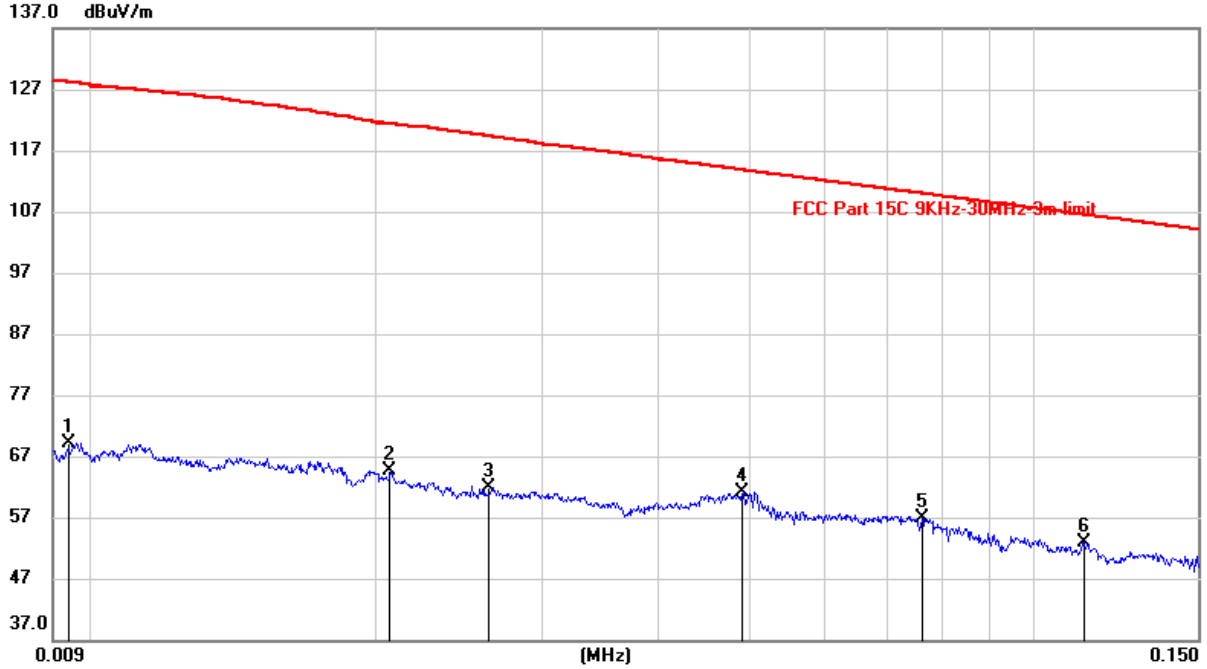

No.	Frequency (MHz)	Reading (dBuV)	Correct (dB/m)	Result (dBuV/m)	Limit (dBuV/m)	Margin (dB)	Remark
1	0.0094	48.90	20.26	69.16	128.06	-58.90	peak
2	0.0206	44.29	20.31	64.60	121.37	-56.77	peak
3	0.0263	41.68	20.31	61.99	119.36	-57.37	peak
4	0.0490	40.78	20.31	61.09	113.81	-52.72	peak
5	0.0761	36.46	20.30	56.76	109.99	-53.23	peak
6	0.1131	32.62	20.27	52.89	106.54	-53.65	peak

Note: 1. Measurement = Reading Level + Correct Factor.
 2. All the modes had been tested, but only the worst data were recorded in the report.
 3. If Peak Result complies with AV and QP limit, AV and QP Result are deemed to comply with AV limit.



150KHz ~ 30M

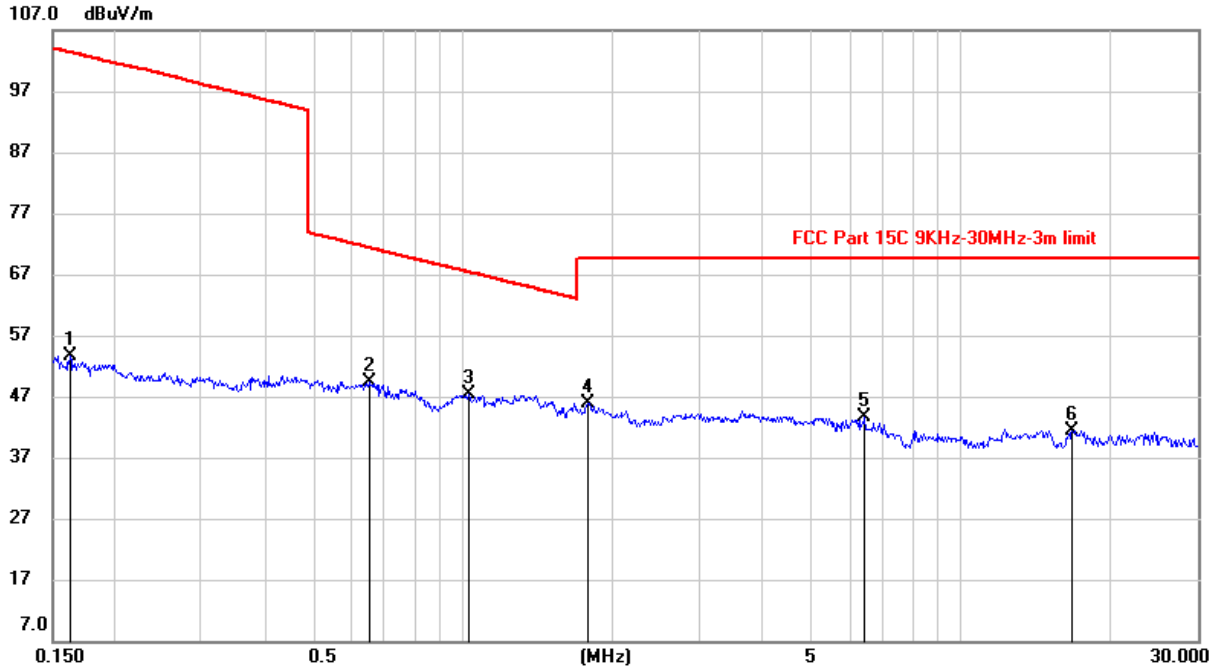

No.	Frequency (MHz)	Reading (dBuV)	Correct (dB/m)	Result (dBuV/m)	Limit (dBuV/m)	Margin (dB)	Remark
1	0.1621	33.11	20.41	53.52	103.41	-49.89	peak
2	0.6471	29.10	20.31	49.41	71.41	-22.00	peak
3	1.0262	26.98	20.38	47.36	67.39	-20.03	peak
4	1.7802	25.33	20.65	45.98	69.54	-23.56	peak
5	6.4198	22.66	20.89	43.55	69.54	-25.99	peak
6	16.7497	20.47	20.97	41.44	69.54	-28.10	peak

Note: 1. Measurement = Reading Level + Correct Factor.
 2. All the modes had been tested, but only the worst data were recorded in the report.
 3. If Peak Result complies with AV and QP limit, AV and QP Result are deemed to comply with AV limit.

Note: All the channels had been tested, but only the worst data recorded in the report.

10. AC POWER LINE CONDUCTED EMISSIONS

LIMITS

Please refer to FCC §15.207 (a)

FREQUENCY (MHz)	Class A (dBuV)		Class B (dBuV)	
	Quasi-peak	Average	Quasi-peak	Average
0.15 -0.5	79.00	66.00	66 - 56 *	56 - 46 *
0.50 -5.0	73.00	60.00	56.00	46.00
5.0 -30.0	73.00	60.00	60.00	50.00

TEST SETUP AND PROCEDURE

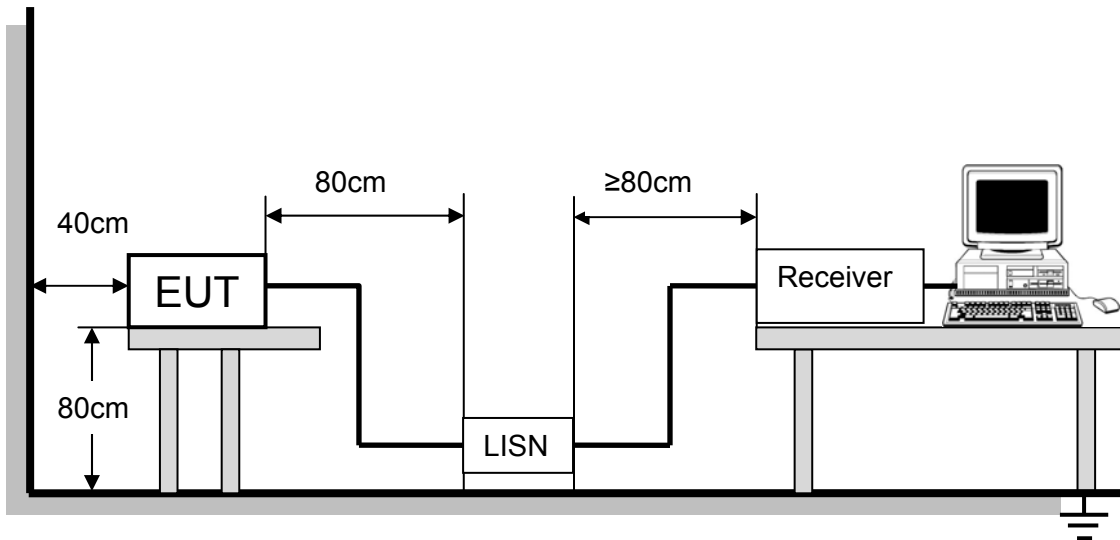

The EUT is put on a table of non-conducting material that is 80cm high. The vertical conducting wall of shielding is located 40cm to the rear of the EUT. The power line of the EUT is connected to the AC mains through a Artificial Mains Network (A.M.N.). A EMI Measurement Receiver (R&S Test Receiver ESR3) is used to test the emissions from both sides of AC line. According to the requirements in Section 6.2 of ANSI C63.10-2013. Conducted emissions from the EUT measured in the frequency range between 0.15 MHz and 30MHz using CISPR Quasi-Peak and average detector mode. The bandwidth of EMI test receiver is set at 9kHz.

The arrangement of the equipment is installed to meet the standards and operating in a manner, which tends to maximize its emission characteristics in a normal application.



LINE N RESULTS (LOW CHANNEL, WORST-CASE CONFIGURATION)

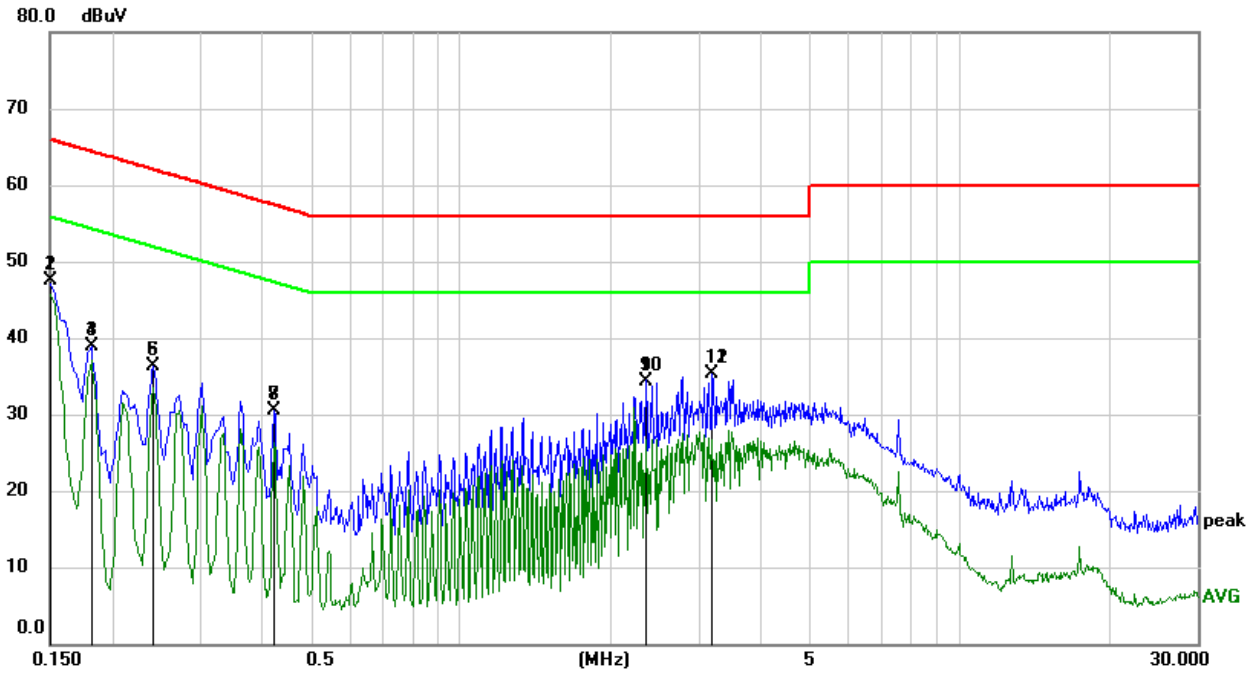

No.	Frequency (MHz)	Reading (dBuV)	Correct (dB)	Result (dBuV)	Limit (dBuV)	Margin (dB)	Remark
1	0.1500	37.93	9.62	47.55	66.00	-18.45	QP
2	0.1500	37.93	9.62	47.55	56.00	-8.45	AVG
3	0.1819	29.30	9.62	38.92	64.40	-25.48	QP
4	0.1819	29.30	9.62	38.92	54.40	-15.48	AVG
5	0.2419	26.76	9.63	36.39	62.03	-25.64	QP
6	0.2420	26.76	9.63	36.39	52.03	-15.64	AVG
7	0.4219	20.79	9.63	30.42	57.41	-26.99	QP
8	0.4220	20.79	9.63	30.42	47.41	-16.99	AVG
9	2.3580	24.74	9.66	34.40	56.00	-21.60	QP
10	2.3580	24.74	9.66	34.40	46.00	-11.60	AVG
11	3.2058	25.65	9.68	35.33	56.00	-20.67	QP
12	3.2060	25.65	9.68	35.33	46.00	-10.67	AVG

- Note: 1. Result = Reading +Correct Factor.
 2. If QP Result complies with AV limit, AV Result is deemed to comply with AV limit.
 3. Test setup: RBW: 200 Hz (9 kHz—150 kHz), 9 kHz (150 kHz—30 MHz).
 4. Step size: 80Hz (0.009MHz-0.15MHz), 4 kHz (0.15MHz-30MHz), Scan time: auto.



LINE L RESULTS (LOW CHANNEL, WORST-CASE CONFIGURATION)

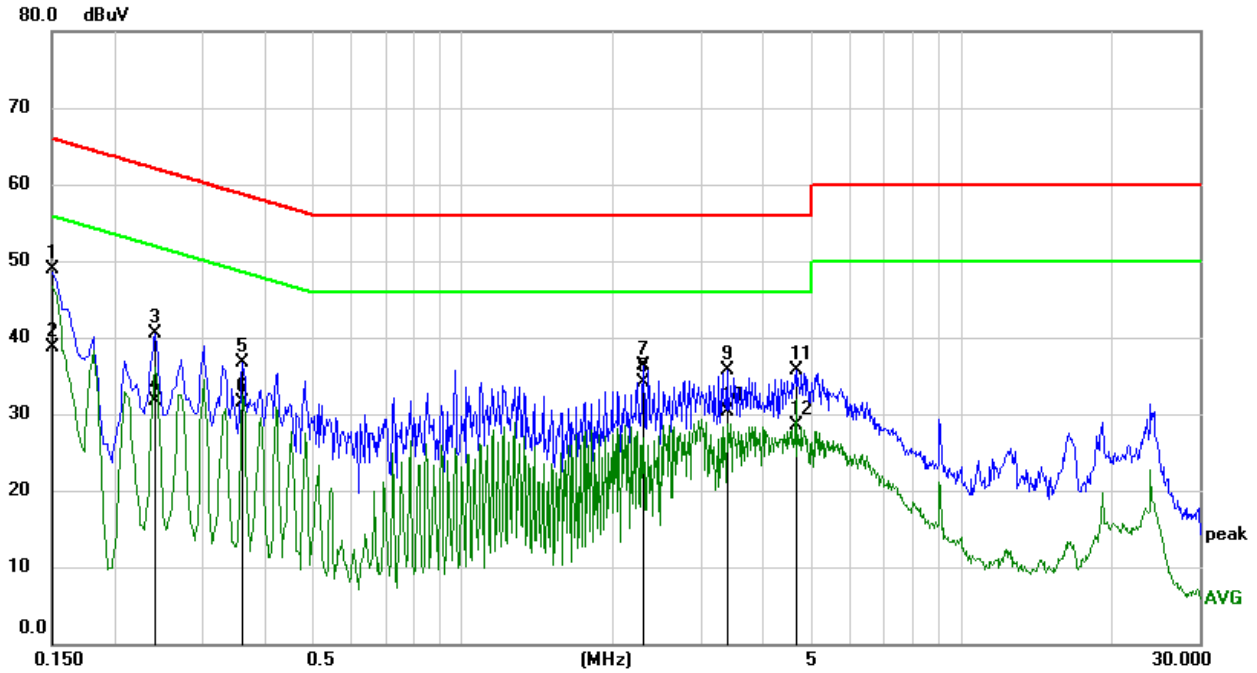

No.	Frequency (MHz)	Reading (dBuV)	Correct (dB)	Result (dBuV)	Limit (dBuV)	Margin (dB)	Remark
1	0.1500	39.34	9.62	48.96	66.00	-17.04	QP
2	0.1500	29.13	9.62	38.75	56.00	-17.25	AVG
3	0.2419	30.86	9.63	40.49	62.03	-21.54	QP
4	0.2419	22.13	9.63	31.76	52.03	-20.27	AVG
5	0.3618	26.99	9.63	36.62	58.69	-22.07	QP
6	0.3620	21.80	9.63	31.43	48.68	-17.25	AVG
7	2.2980	26.68	9.66	36.34	56.00	-19.66	QP
8	2.2980	24.47	9.66	34.13	46.00	-11.87	AVG
9	3.3860	26.07	9.68	35.75	56.00	-20.25	QP
10	3.3860	20.60	9.68	30.28	46.00	-15.72	AVG
11	4.6500	26.03	9.70	35.73	56.00	-20.27	QP
12	4.6500	18.73	9.70	28.43	46.00	-17.57	AVG

- Note: 1. Result = Reading +Correct Factor.
 2. If QP Result complies with AV limit, AV Result is deemed to comply with AV limit.
 3. Test setup: RBW: 200 Hz (9 kHz—150 kHz), 9 kHz (150 kHz—30 MHz).
 4. Step size: 80Hz (0.009MHz-0.15MHz), 4 kHz (0.15MHz-30MHz), Scan time: auto.

Note: All the channels had been tested, but only the worst data recorded in the report.



11. ANTENNA REQUIREMENTS

Applicable requirements

Please refer to FCC §15.203

An intentional radiator shall be designed to ensure that no antenna other than that furnished by the responsible party shall be used with the device. The use of a permanently attached antenna or of an antenna that uses a unique coupling to the intentional radiator shall be considered sufficient to comply with the provisions of this section. The manufacturer may design the unit so that a broken antenna can be replaced by the user, but the use of a standard antenna jack or electrical connector is prohibited.

Please refer to FCC §15.247(b)(4)

The conducted output power limit specified in paragraph (b) of this section is based on the use of antennas with directional gains that do not exceed 6 dBi. Except as shown in paragraph (c) of this section, if transmitting antennas of directional gain greater than 6 dBi are used, the conducted output power from the intentional radiator shall be reduced below the stated values in paragraphs (b)(1), (b)(2), and (b)(3) of this section, as appropriate, by the amount in dB that the directional gain of the antenna exceeds 6 dBi.

Antenna Connector

EUT has a PCB antenna without antenna connector.

Antenna Gain

The antenna gain of EUT is less than 6 dBi.



END OF REPORT