



FCC TEST REPORT
FOR
REALTRACK SYSTEMS SL
WIMU PRO EVO
Test Model: WT200

Prepared for : REALTRACK SYSTEMS SL
Address : Calle Guinea, 2; Almería, 04009

Prepared by : Shenzhen LCS Compliance Testing Laboratory Ltd.
Address : 101, 201 Bldg A & 301 Bldg C, Juji Industrial Park Yabianxueziwei,
Shajing Street, Baoan District, Shenzhen, 518000, China

Tel : (+86)755-82591330
Fax : (+86)755-82591332
Web : www.LCS-cert.com
Mail : webmaster@LCS-cert.com

Date of receipt of test sample : May 05, 2023
Number of tested samples : 2
Sample No. : A042623040-1,A042623040-2
Serial number : Prototype
Date of Test : May 05, 2023 ~ July 11, 2023
Date of Report : July 12, 2023



Shenzhen LCS Compliance Testing Laboratory Ltd.
Add: 101, 201 Bldg A & 301 Bldg C, Juji Industrial Park Yabianxueziwei, Shajing Street, Baoan District, Shenzhen, 518000, China
Tel: +(86) 0755-82591330 | E-mail: webmaster@lcs-cert.com | Web: www.lcs-cert.com
Scan code to check authenticity



FCC TEST REPORT

FCC CFR 47 PART 15 F(15.519&15.521)

Report Reference No. : LCSA042623040ED

Date of Issue : July 12, 2023

Testing Laboratory Name : Shenzhen LCS Compliance Testing Laboratory Ltd.

Address : 101, 201 Bldg A & 301 Bldg C, Juji Industrial Park Yabianxueziwei, Shajing Street, Baoan District, Shenzhen, 518000, China

Testing Location/ Procedure : Full application of Harmonised standards ■
Partial application of Harmonised standards □
Other standard testing method □

Applicant's Name : REALTRACK SYSTEMS SL

Address : Calle Guinea, 2; Almería, 04009

Test Specification

Standard : FCC CFR 47 PART 15F(15.519&15.521)

Test Report Form No. : LCSEMC-1.0

TRF Originator : Shenzhen LCS Compliance Testing Laboratory Ltd.

Master TRF : Dated 2022-08

Shenzhen LCS Compliance Testing Laboratory Ltd. All rights reserved.

This publication may be reproduced in whole or in part for non-commercial purposes as long as the Shenzhen LCS Compliance Testing Laboratory Ltd. is acknowledged as copyright owner and source of the material. Shenzhen LCS Compliance Testing Laboratory Ltd. takes no responsibility for and will not assume liability for damages resulting from the reader's interpretation of the reproduced material due to its placement and context.

Test Item Description. : WIMU PRO EVO

Trade Mark : WIMU WT200

Test Model : WT200

Ratings : DC 3.7V by Rechargeable Li-ion Battery, 1300mAh

Result : Positive

Compiled by:

Jack Liu

Jack Liu/ Administrator

Supervised by:

Cary Luo

Cary Luo/ Technique principal

Approved by:

Gavin Liang

Gavin Liang / Manager



Shenzhen LCS Compliance Testing Laboratory Ltd.
Add: 101, 201 Bldg A & 301 Bldg C, Juji Industrial Park Yabianxueziwei, Shajing Street, Baoan District, Shenzhen, 518000, China
Tel: +(86) 0755-82591330 | E-mail: webmaster@lcs-cert.com | Web: www.lcs-cert.com
Scan code to check authenticity



FCC -- TEST REPORT

Test Report No. : LCSA042623040ED	<u>July 12, 2023</u> Date of issue
--	---------------------------------------

Test Model.....	: WT200
EUT.....	: WIMU PRO EVO
Applicant.....	: REALTRACK SYSTEMS SL
Address.....	: Calle Guinea, 2; Almería, 04009
Telephone.....	: /
Fax.....	: /
Manufacturer.....	: REALTRACK SYSTEMS SL
Address.....	: Calle Guinea, 2; Almería, 04009
Telephone.....	: /
Fax.....	: /
Factory.....	: REALTRACK SYSTEMS SL
Address.....	: Calle Guinea, 2; Almería, 04009
Telephone.....	: /
Fax.....	: /

Test Result	Positive
--------------------	-----------------

The test report merely corresponds to the test sample.
It is not permitted to copy extracts of these test result without the written permission of the test laboratory.



Shenzhen LCS Compliance Testing Laboratory Ltd.
Add: 101, 201 Bldg A & 301 Bldg C, Juji Industrial Park Yabianxueziwei, Shajing Street, Baoan District, Shenzhen, 518000, China
Tel: +(86) 0755-82591330 | E-mail: webmaster@lcs-cert.com | Web: www.lcs-cert.com
Scan code to check authenticity



Revision History

Report Version	Issue Date	Revision Content	Revised By
000	July 12, 2023	Initial Issue	---



Shenzhen LCS Compliance Testing Laboratory Ltd.
 Add: 101, 201 Bldg A & 301 Bldg C, Juji Industrial Park Yabianxueziwei, Shajing Street, Baoan District, Shenzhen, 518000, China
 Tel: +(86) 0755-82591330 | E-mail: webmaster@lcs-cert.com | Web: www.lcs-cert.com
 Scan code to check authenticity



TABLE OF CONTENTS

Description	Page
1. GENERAL INFORMATION	6
1.1 Description of Device (EUT)	6
1.2 Support equipment List.....	7
1.3 External I/O Cable	7
1.4 Description of Test Facility	7
1.5 Statement of the Measurement Uncertainty.....	7
1.6 Measurement Uncertainty	7
1.7 Description of Test Modes	9
2. TEST METHODOLOGY	10
2.1 EUT Configuration.....	10
2.2 EUT Exercise	10
2.3 General Test Procedures	10
2.4. Test Sample	10
3. SYSTEM TEST CONFIGURATION	11
3.1 Justification.....	11
3.2 EUT Exercise Software	11
3.3 Special Accessories.....	11
3.4 Block Diagram/Schematics.....	10
3.5 Equipment Modifications	11
3.6 Test Setup	11
4. SUMMARY OF TEST RESULTS	12
5. SUMMARY OF TEST EQUIPMENT	13
6. MEASUREMENT RESULTS.....	14
6.1. UWB transmitters employed solely for indoor operation.....	14
6.2. Spurious Radiated Emissions	14
6.3. UWB Bandwidth	23
6.4. AC Power Line Conducted Emissions	24
6.5. Antenna Requirement.....	29
6.6. Peak Emissions within a 50 MHz Bandwidth	30
6.7. Radiated Emissions in GPS Bands	33
7. TEST SETUP PHOTOGRAPHS OF EUT	37
8. EXTERIOR PHOTOGRAPHS OF THE EUT	37
9. INTERIOR PHOTOGRAPHS OF THE EUT	37





1. GENERAL INFORMATION

1.1 Description of Device (EUT)

EUT : WIMU PRO EVO

Test Model : WT200

Power Supply : DC 3.7V by Rechargeable Li-ion Battery, 1300mAh

Hardware Version : V.2

Software Version : V.1.0.0

Bluetooth :

Frequency Range : 2402MHz~2480MHz

Channel Number : 79 channels for Bluetooth V5.1(DSS)
40 channels for Bluetooth V5.1 (DTS)

Channel Spacing : 1MHz for Bluetooth V5.1 (DSS)
2MHz for Bluetooth V5.1 (DTS)

Modulation Type : GFSK, $\pi/4$ -DQPSK, 8-DPSK for Bluetooth V5.1(DSS)
GFSK for Bluetooth V5.1 (DTS)

Bluetooth Version : V5.1

Antenna Description : Internal Antenna, 1.0dBi(Max.)

WIFI(2.4G Band) :

Frequency Range : 2412MHz~2462MHz

Channel Spacing : 5MHz

Channel Number : 11 Channels for 20MHz bandwidth (2412~2462MHz)

Modulation Type : IEEE 802.11b: DSSS (CCK, DQPSK, DBPSK)
IEEE 802.11g: OFDM (64QAM, 16QAM, QPSK, BPSK)
IEEE 802.11n: OFDM (64QAM, 16QAM, QPSK, BPSK)

Antenna Description : Internal Antenna, 1.0dBi(Max.)

UWB :

Frequency Range : 3200MHz~7200MHz

Channel Number : 4

Channel Frequency : 3494.4MHz, 3993.6MHz, 4492.8MHz, 6489.6MHz

Modulation Type : BPSK

Antenna Description : Internal Antenna, 4.16dBi(Max.)

ANT+ :

Frequency Range : 2400MHz~2483.5MHz

Antenna Description : Internal Antenna, 1.3dBi(Max.)

GPS function : Support and only RX



Shenzhen LCS Compliance Testing Laboratory Ltd.

Add: 101, 201 Bldg A & 301 Bldg C, Juji Industrial Park Yabianxueziwei, Shajing Street, Baoan District, Shenzhen, 518000, China

Tel: +(86) 0755-82591330 | E-mail: webmaster@lcs-cert.com | Web: www.lcs-cert.com

Scan code to check authenticity



1.2 Support equipment List

Manufacturer	Description	Model	Serial Number	Certificate
Ubiquiti Networks, Inc.	AC/DC/PoE POWER	GP-A240-050	---	FCC

1.3 External I/O Cable

I/O Port Description	Quantity	Cable
USB Port	1	N/A

1.4 Description of Test Facility

NVLAP Accreditation Code is 600167-0.

FCC Designation Number is CN5024.

CAB identifier is CN0071.

CNAS Registration Number is L4595.

Test Firm Registration Number: 254912.

The 3m-Semi anechoic test site fulfills CISPR 16-1-4 according to ANSI C63.10:2013 and CISPR 16-1-4:2010 SVSWR requirement for radiated emission above 1GHz.

1.5 Statement of the Measurement Uncertainty

The data and results referenced in this document are true and accurate. The reader is cautioned that there may be errors within the calibration limits of the equipment and facilities. The measurement uncertainty was calculated for all measurements listed in this test report acc. To CISPR 16 – 4 “Specification for radio disturbance and immunity measuring apparatus and methods – Part 4: Uncertainty in EMC Measurements” and is documented in the LCS quality system acc. To DIN EN ISO/IEC 17025. Furthermore, component and process variability of devices similar to that tested may result in additional deviation. The manufacturer has the sole responsibility of continued compliance of the device.



1.6 Measurement Uncertainty

Test Item	Frequency Range	Uncertainty	Note
Radiation Uncertainty	9KHz~30MHz	±3.10dB	(1)
	30MHz~200MHz	±2.96dB	(1)
	200MHz~1000MHz	±3.10dB	(1)
	1GHz~26.5GHz	±3.80dB	(1)
	26.5GHz~40GHz	±3.90dB	(1)
Conduction Uncertainty	150kHz~30MHz	±1.63dB	(1)
Power disturbance	30MHz~300MHz	±1.60dB	(1)
Output power	1GHz-40GHz	±0.57dB	(1)
Power Spectral Density	1GHz-40GHz	±1.2dB	(1)
Occupied Channel Bandwidth	1GHz-40GHz	±5%	(1)
Conducted RF Spurious Emission	9kHz-40GHz	±1.80dB	(1)
Emissions in Restricted Bands	1GHz-40GHz	±2.47dB	(1)

(1). This uncertainty represents an expanded uncertainty expressed at approximately the 95% confidence level using a coverage factor of k=2.





1.7 Description of Test Modes

The EUT works in the X-axis, Y-axis, Z-axis. The following operating modes were applied for the related test items. All test modes were tested, only the result of the worst case was recorded in the report.

Mode of Operations	Frequency Range (MHz)
UWB	3200MHz~7200MHz

Worst-case mode and channel used for 150 KHz-30 MHz power line conducted emissions was determined to be TX.

Worst-case mode and channel used for 9 KHz-1000 MHz radiated emissions was determined to be TX.

Pre-test AC conducted emission at charge from Channel(7290MHz) mode, recorded worst case.

Pre-test AC conducted emission at both voltage AC 120V/60Hz and AC 240V/60Hz, recorded worst case.





2. TEST METHODOLOGY

The tests documented in this report were performed in accordance with ANSI C63.10-2013, FCC CFR PART 15F 15.519 (b) – (e),15.517(a),15.521 and FCC CFR PART 15C 15.203,15.207,15.209.

2.1 EUT Configuration

The EUT configuration for testing is installed on RF field strength measurement to meet the Commissions requirement and operating in a manner that intends to maximize its emission characteristics in a continuous normal application.

2.2 EUT Exercise

The EUT was operated in the normal operating mode for Hopping Numbers and Dwell Time test and a continuous transmits mode for other tests.

According to its specifications, the EUT must comply with the requirements of the Section 15.519 (b) – (e),15.517(a) under the FCC Rules Part 15 Subpart F,15.203,15.207,15.209 under the FCC Rules Part 15 Subpart C.

2.3 General Test Procedures

2.3.1 Conducted Emissions

The EUT is placed on the turntable, which is 0.8 m above ground plane. According to the requirements in Section 6.1.1 of ANSI C63.10-2013 Conducted emissions from the EUT measured in the frequency range between 0.15 MHz and 30MHz using Quasi-peak and average detector modes.

2.3.2 Radiated Emissions

The EUT is placed on a turn table, which is 0.8 m above ground plane below 1GHz and 1.5 m above ground plane above 1GHz. The turntable shall rotate 360 degrees to determine the position of maximum emission level. EUT is set 3m away from the receiving antenna, which varied from 1m to 4m to find out the highest emission. And also, each emission was to be maximized by changing the polarization of receiving antenna both horizontal and vertical. In order to find out the maximum emissions, exploratory radiated emission measurements were made according to the requirements in Section 6.4 of ANSI C63.10-2013

2.4. Test Sample

The application provides 2 samples to meet requirement;

Sample Number	Description
Sample 1(A042623040-1)	Engineer sample – continuous transmit
Sample 2(A042623040-2)	Normal sample – Intermittent transmit





3. SYSTEM TEST CONFIGURATION

3.1 Justification

The system was configured for testing in a continuous transmits condition.

3.2 EUT Exercise Software

The system was configured for testing in a continuous transmits condition

3.3 Special Accessories

Manufacturer	Description	Model	Serial Number	Certificate
--	--	--	--	--

3.4 Block Diagram/Schematics

Please refer to the related document.

3.5 Equipment Modifications

Shenzhen LCS Compliance Testing Laboratory Ltd. has not done any modification on the EUT.

3.6 Test Setup

Please refer to the test setup photo.





4. SUMMARY OF TEST RESULTS

FCC Rules	Description of Test	Test Sample	Result
15.517(a)(1)	UWB transmitters employed solely for indoor operation.	Sample 1	Compliant
15.209, 15.519(c)	Spurious Radiated Emissions	Sample 1 Sample 2	Compliant
15.207	Power Line Conducted	Sample 1 Sample 2	Compliant
15.203	Antenna Requirement	Sample 2	Compliant
15.519 (d)	Radiated Emissions in GPS Bands	Sample 1	Compliant
15.519 (b)	UWB Bandwidth	Sample 1	Compliant
15.519 (e)	Peak Emissions within a 50 MHz Bandwidth	Sample 1	Compliant



Shenzhen LCS Compliance Testing Laboratory Ltd.
Add: 101, 201 Bldg A & 301 Bldg C, Juji Industrial Park Yabianxueziwei, Shajing Street, Baoan District, Shenzhen, 518000, China
Tel: +(86) 0755-82591330 | E-mail: webmaster@lcs-cert.com | Web: www.lcs-cert.com
Scan code to check authenticity



5. SUMMARY OF TEST EQUIPMENT

Item	Equipment	Manufacturer	Model No.	Serial No.	Cal Date	Due Date
1	Power Meter	R&S	NRVS	100444	2022-06-16	2023-06-15
					2023-06-15	2024-06-14
2	Power Sensor	R&S	NRV-Z81	100458	2022-06-16	2023-06-15
					2023-06-15	2024-06-14
3	Power Sensor	R&S	NRV-Z32	10057	2022-06-16	2023-06-15
					2023-06-15	2024-06-14
4	Test Software	Tonscend	JS1120-2	/	N/A	N/A
5	RF Control Unit	Tonscend	JS0806-2	N/A	2022-10-29	2023-10-28
6	MXA Signal Analyzer	Agilent	N9020A	MY50510140	2022-10-29	2023-10-28
7	DC Power Supply	Agilent	E3642A	N/A	2022-10-29	2023-10-28
8	EMI Test Software	AUDIX	E3	/	N/A	N/A
9	3m Semi Anechoic Chamber	SIDT FRANKONIA	SAC-3M	03CH03-HY	2022-06-16	2023-06-15
					2023-06-15	2024-06-14
10	Positioning Controller	Max-Full	MF7802BS	MF780208586	N/A	N/A
11	Active Loop Antenna	SCHWARZBECK	FMZB 1519B	00005	2021-08-29	2024-08-28
12	By-log Antenna	SCHWARZBECK	VULB9163	9163-470	2021-09-12	2024-09-11
13	Horn Antenna	SCHWARZBECK	BBHA 9120D	9120D-1925	2021-09-05	2024-09-04
14	Broadband Horn Antenna	SCHWARZBECK	BBHA 9170	791	2021-08-29	2024-08-28
15	Broadband Preamplifier	SCHWARZBECK	BBV9719	9719-025	2022-06-16	2023-06-15
					2023-06-15	2024-06-14
16	EMI Test Receiver	R&S	ESR 7	101181	2022-06-16	2023-06-15
					2023-06-15	2024-06-14
17	RS SPECTRUM ANALYZER	R&S	FSP40	100503	2022-10-29	2023-10-28
18	Broadband Preamplifier	/	BP-01M18G	P190501	2022-06-16	2023-06-15
					2023-06-15	2024-06-14
19	6dB Attenuator	/	100W/6dB	1172040	2022-06-16	2023-06-15
					2023-06-15	2024-06-14
20	3dB Attenuator	/	2N-3dB	/	2022-10-29	2023-10-28
21	EMI Test Receiver	R&S	ESPI	101940	2022-08-18	2023-08-17
22	Artificial Mains	R&S	ENV216	101288	2022-06-16	2023-06-15
					2023-06-15	2024-06-14
23	10dB Attenuator	SCHWARZBECK	MTS-IMP-136	261115-001-0032	2022-06-16	2023-06-15
					2023-06-15	2024-06-14
24	EMI Test Software	Farad	EZ	/	N/A	N/A



Shenzhen LCS Compliance Testing Laboratory Ltd.

Add: 101, 201 Bldg A & 301 Bldg C, Juji Industrial Park Yabianxueziwei, Shajing Street, Baoan District, Shenzhen, 518000, China

Tel: +(86) 0755-82591330 | E-mail: webmaster@lcs-cert.com | Web: www.lcs-cert.com

Scan code to check authenticity



6. MEASUREMENT RESULTS

6.1. UWB transmitters employed solely for indoor operation.

6.1.1 Limit

- 1) Indoor UWB devices, by the nature of their design, must be capable of operation only indoors. The necessity to operate with a fixed indoor infrastructure, e.g., a transmitter that must be connected to the AC power lines, may be considered sufficient to demonstrate this.
- 2) The emissions from equipment operated under this section shall not be intentionally directed outside of the building in which the equipment is located, such as through a window or a doorway, to perform an outside function, such as the detection of persons about to enter a building.
- 3) The use of outdoor mounted antennas, e.g., antennas mounted on the outside of a building or on a telephone pole, or any other outdoors infrastructure is prohibited.

6.1.2. Test result:

Described in the integration manual



Shenzhen LCS Compliance Testing Laboratory Ltd.
Add: 101, 201 Bldg A & 301 Bldg C, Juji Industrial Park Yabianxueziwei, Shajing Street, Baoan District, Shenzhen, 518000, China
Tel: +(86) 0755-82591330 | E-mail: webmaster@lcs-cert.com | Web: www.lcs-cert.com
Scan code to check authenticity



6.2. Spurious Radiated Emissions

6.2.1. Standard Applicable

47 CFR Part 15F Section 15.519(c)&47 CFR Part 15F Section 15.209;

6.2.2. Limit

The radiated limits of FCC 15.209 are shown below. The limits specified are at 3 meters. The limits are quasi-peak for emissions below 1 GHz.

Frequencies (MHz)	Field Strength (microvolts/meter)	Measurement Distance (meters)
0.009~0.490	2400/F(KHz)	300
0.490~1.705	24000/F(KHz)	30
1.705~30.0	30	30
30~88	100	3
88~216	150	3
216~960	200	3
Above 960	500	3

The radiated limits of FCC 15.519c are shown below. The limits specified are at 3 meters.

Frequency (MHz)	EIRP in dBm	E-Field(dBuV/m) at 3m measurement distance (Note1)	E-Field(dBuV/m) at 1m measurement distance (Note1 and Note 2)	E-Field(dBuV/m) at 0.5m measurement distance (Note1 and Note2)
960-1610	-75.3	20	29.54	35.56
1610-1990	-63.3	32	41.54	47.56
1990-3100	-61.3	34	43.54	49.56
3100-10600	-41.3	54	63.54	69.56
Above 10600	-61.3	34	43.54	49.56

Note1:According procedures for **measuring ultra-wideband devices,10.3.9 Determination of EIRP**
 $EIRP(dBm) = E(dBuV/m) - 95.3$ at a specified measurement distance of 3 m

Note 2: Distance extrapolation factor = $20 \log(\text{specific distance} / \text{test distance})$ (dB)

6.2.3. Test Procedures

1) Sequence of testing 9 kHz to 30 MHz

Setup:

- The equipment was set up to simulate a typical usage like described in the user manual or described by manufacturer.
- If the EUT is a tabletop system, a rotatable table with 0.8 m height is used.
- If the EUT is a floor standing device, it is placed on the ground.
- Auxiliary equipment and cables were positioned to simulate normal operation conditions.





- The AC power port of the EUT (if available) is connected to a power outlet below the turntable.
- The measurement distance is 3 meter.
- The EUT was set into operation.

Premeasurement:

- The turntable rotates from 0° to 315° using 45° steps.
- The antenna height is 1.0 meter.
- At each turntable position the analyzer sweeps with peak detection to find the maximum of all emissions

Final measurement:

- Identified emissions during the premeasurement the software maximizes by rotating the turntable position (0° to 360°) and by rotating the elevation axes (0° to 360°).
- The final measurement will be done in the position (turntable and elevation) causing the highest emissions with QPK detector.
- The final levels, frequency, measuring time, bandwidth, turntable position, correction factor, margin to the limit and limit will be recorded. Also a plot with the graph of the premeasurement and the limit will be stored.

2) Sequence of testing 30 MHz to 1 GHz**Setup:**

- The equipment was set up to simulate a typical usage like described in the user manual or described by manufacturer.
- If the EUT is a tabletop system, a table with 0.8 m height is used, which is placed on the ground plane.
- If the EUT is a floor standing device, it is placed on the ground plane with insulation between both.
- Auxiliary equipment and cables were positioned to simulate normal operation conditions
- The AC power port of the EUT (if available) is connected to a power outlet below the turntable.
- The measurement distance is 3 meter.
- The EUT was set into operation.

Premeasurement:

- The turntable rotates from 0° to 315° using 45° steps.
- The antenna is polarized vertical and horizontal.
- The antenna height changes from 1 to 3 meter.
- At each turntable position, antenna polarization and height the analyzer sweeps three times in peak to find the maximum of all emissions.

Final measurement:

- The final measurement will be performed with minimum the six highest peaks.
- According to the maximum antenna and turntable positions of premeasurement the software maximize the peaks by changing turntable position ($\pm 45^\circ$) and antenna movement between 1 and 4 meter.
- The final measurement will be done with QP detector with an EMI receiver.
- The final levels, frequency, measuring time, bandwidth, antenna height, antenna polarization,



Shenzhen LCS Compliance Testing Laboratory Ltd.

Add: 101, 201 Bldg A & 301 Bldg C, Juji Industrial Park Yabianxueziwei, Shajing Street, Baoan District, Shenzhen, 518000, China

Tel: +(86) 0755-82591330 | E-mail: webmaster@lcs-cert.com | Web: www.lcs-cert.com

Scan code to check authenticity



turntable angle, correction factor, margin to the limit and limit will be recorded. Also a plot with the graph of the premeasurement with marked maximum final measurements and the limit will be stored.

3) Sequence of testing 1 GHz to 18 GHz

Setup:

- The equipment was set up to simulate a typical usage like described in the user manual or described by manufacturer.
- If the EUT is a tabletop system, a rotatable table with 1.5 m height is used.
- If the EUT is a floor standing device, it is placed on the ground plane with insulation between both.
- Auxiliary equipment and cables were positioned to simulate normal operation conditions
- The AC power port of the EUT (if available) is connected to a power outlet below the turntable.
- The measurement distance is 1 meter.
- The EUT was set into operation.

Premeasurement:

- The turntable rotates from 0° to 315° using 45° steps.
- The antenna is polarized vertical and horizontal.
- The antenna height scan range is 1 meter to 2.5 meter.
- At each turntable position and antenna polarization the analyzer sweeps with peak detection to find the maximum of all emissions.

Final measurement:

- The final measurement will be performed with minimum the six highest peaks.
- According to the maximum antenna and turntable positions of premeasurement the software maximize the peaks by changing turntable position ($\pm 45^\circ$) and antenna movement between 1 and 4 meter. This procedure is repeated for both antenna polarizations.
- The final measurement will be done in the position (turntable, EUT-table and antenna polarization) causing the highest emissions with Peak and Average detector.
- The final levels, frequency, measuring time, bandwidth, turntable position, EUT-table position, antenna polarization, correction factor, margin to the limit and limit will be recorded. Also a plot with the graph of the premeasurement with marked maximum final measurements and the limit will be stored.





4) Sequence of testing above 18 GHz

Setup:

- The equipment was set up to simulate a typical usage like described in the user manual or described by manufacturer.
- If the EUT is a tabletop system, a rotatable table with 1.5 m height is used.
- If the EUT is a floor standing device, it is placed on the ground plane with insulation between both.
- Auxiliary equipment and cables were positioned to simulate normal operation conditions
- The AC power port of the EUT (if available) is connected to a power outlet below the turntable.
- The measurement distance is 0.5 meter.
- The EUT was set into operation.

Premeasurement:

- The antenna is moved spherical over the EUT in different polarizations of the antenna.

Final measurement:

- The final measurement will be performed at the position and antenna orientation for all detected emissions that were found during the premeasurements with Peak and Average detector.
- The final levels, frequency, measuring time, bandwidth, correction factor, margin to the limit and limit will be recorded. Also a plot with the graph of the premeasurement and the limit will be stored.

Measuring Instruments and Setting

Spectrum Parameter	Setting
Attenuation	Auto
Start Frequency	1000 MHz
Stop Frequency	10 th carrier harmonic
RB / VB (Emission in restricted band)	1MHz / 1MHz for Peak, 1 MHz / 1/B kHz for Average
RB / VB (Emission in non-restricted band)	1MHz / 1MHz for Peak, 1 MHz / 1/B kHz for Average

Receiver Parameter	Setting
Attenuation	Auto
Start ~ Stop Frequency	9kHz~150kHz / RB/VB 200Hz/1KHz for QP/AVG
Start ~ Stop Frequency	150kHz~30MHz / RB/VB 9kHz/30KHz for QP/AVG
Start ~ Stop Frequency	30MHz~1000MHz / RB/VB 120kHz/1MHz for QP

6.2.4. Test Setup Layout

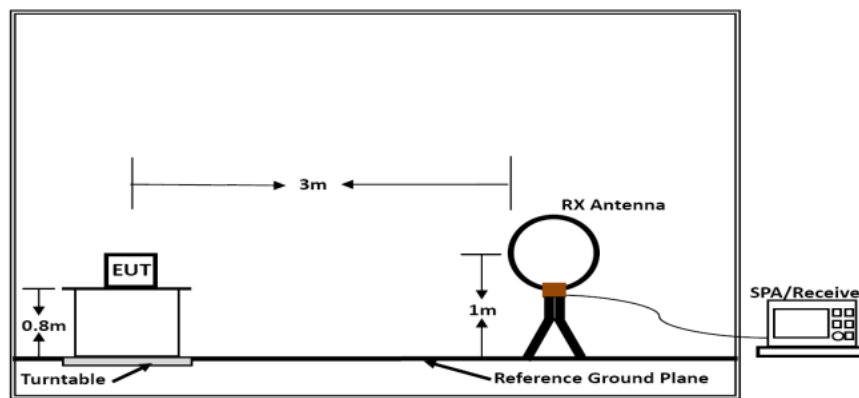

Below 30MHz



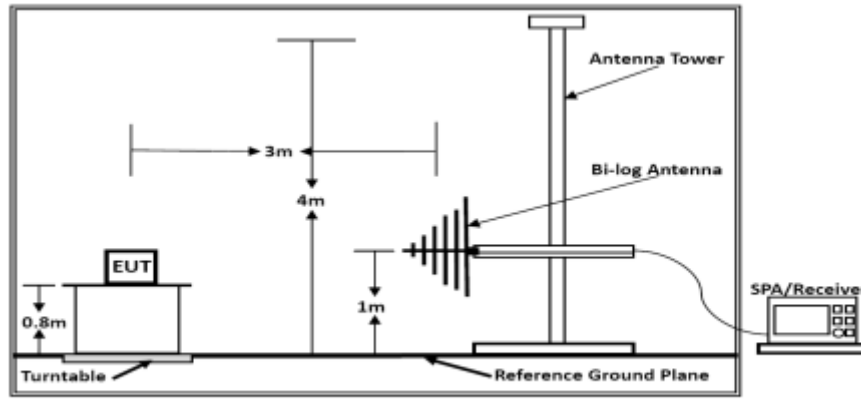

Below 1GHz

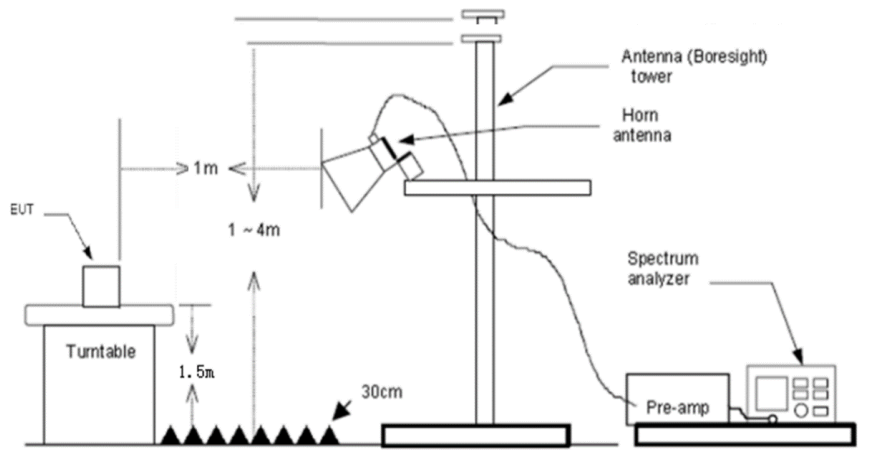

Above 18 GHz shall be extrapolated to the specified distance using an extrapolation factor of 20 dB/decade form 3m to 1m.

6.2.5. EUT Operation during Test

The EUT was programmed to be in continuously transmitting mode.

6.2.6. Test Result

Temperature	23.8°C	Humidity	52.1%
Test Engineer	Nick Peng	Configurations	UWB

Freq. (MHz)	Level (dBuV)	Over Limit (dB)	Over Limit (dB)	Remark
-	-	-	-	See Note

Note:

The amplitude of spurious emissions for 30MHz below which are attenuated by more than 20 dB below the permissible value has no need to be reported.

Distance extrapolation factor = $40 \log(\text{specific distance} / \text{test distance})$ (dB);

Limit line = specific limits (dBuV) + distance extrapolation factor.





6.2.7. Results of Radiated Emissions (30 MHz~1 GHz)

Temperature	23.8°C	Humidity	52.1%
Test Engineer	Nick Peng	Configurations	UWB

PASS.

The test data please refer to following page.



Shenzhen LCS Compliance Testing Laboratory Ltd.
Add: 101, 201 Bldg A & 301 Bldg C, Juji Industrial Park Yabianxueziwei, Shajing Street, Baoan District, Shenzhen, 518000, China
Tel: +(86) 0755-82591330 | E-mail: webmaster@lcs-cert.com | Web: www.lcs-cert.com
Scan code to check authenticity



Horizontal

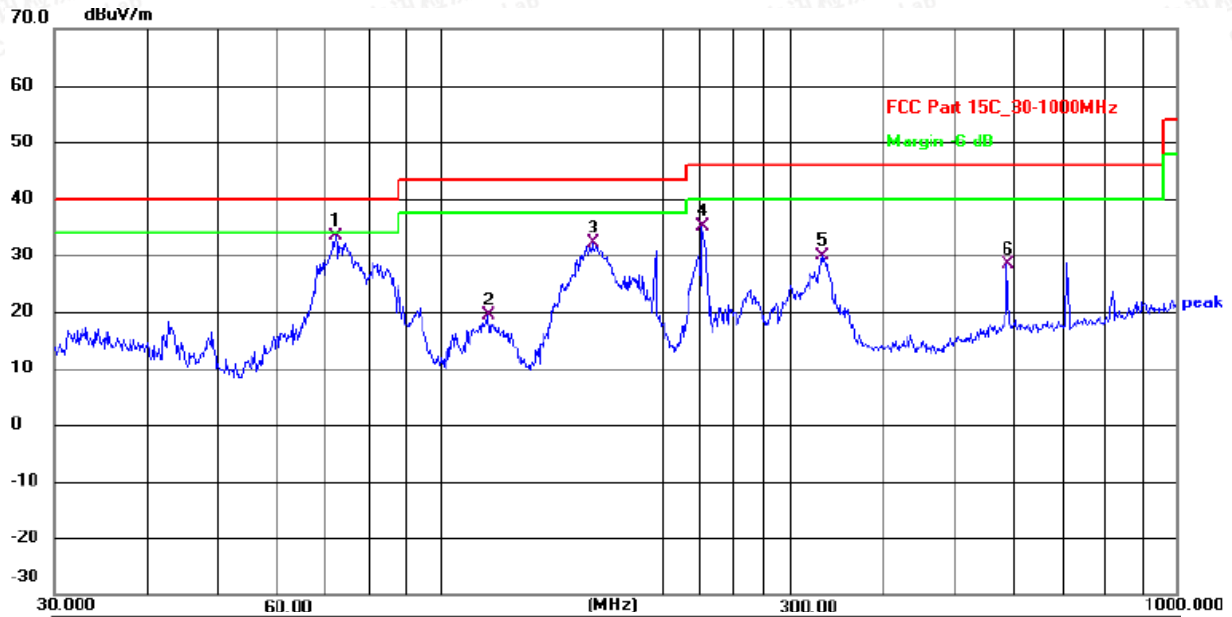

No.	Frequency (MHz)	Reading (dBuV)	Factor (dB/m)	Level (dBuV/m)	Limit (dBuV/m)	Margin (dB)	Detector
1	72.3375	52.90	-19.56	33.34	40.00	-6.66	QP
2	116.1321	38.88	-19.59	19.29	43.50	-24.21	QP
3	161.4740	51.79	-19.66	32.13	43.50	-11.37	QP
4	226.8936	51.78	-16.66	35.12	46.00	-10.88	QP
5	330.1948	44.16	-14.33	29.83	46.00	-16.17	QP
6	588.9050	39.03	-10.63	28.40	46.00	-17.60	QP



Shenzhen LCS Compliance Testing Laboratory Ltd.
 Add: 101, 201 Bldg A & 301 Bldg C, Juji Industrial Park Yabianxueziwei, Shajing Street, Baoan District, Shenzhen, 518000, China
 Tel: +(86) 0755-82591330 | E-mail: webmaster@lcs-cert.com | Web: www.lcs-cert.com
 Scan code to check authenticity



Vertical

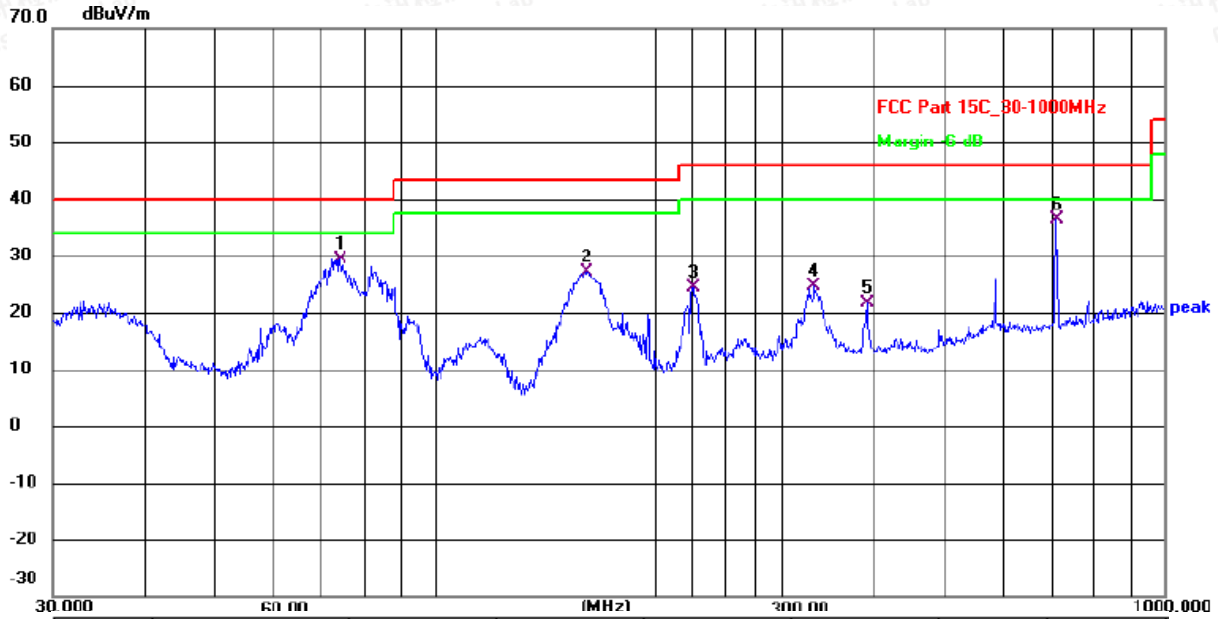

No.	Frequency (MHz)	Reading (dBuV)	Factor (dB/m)	Level (dBuV/m)	Limit (dBuV/m)	Margin (dB)	Detector
1	74.1351	48.97	-19.64	29.33	40.00	-10.67	QP
2	161.4742	46.91	-19.66	27.25	43.50	-16.25	QP
3	225.3080	41.23	-16.74	24.49	46.00	-21.51	QP
4	331.3546	38.90	-14.36	24.54	46.00	-21.46	QP
5	390.7226	36.06	-14.54	21.52	46.00	-24.48	QP
6	709.1823	47.11	-10.77	36.34	46.00	-9.66	QP

Note:

- 1). Pre-scan all modes and recorded the worst case results in this report UWB mode (3993.6MHz).
- 2). Emission level (dBuV/m) = 20 log Emission level (uV/m).
- 3). Level = Reading + Factor, Margin = Level – Limit, Factor = Antenna Factor + Cable Loss - Preamp Factor





5.8.8. Results for Radiated Emissions (at 1m for 960 – 18GHz)

Note: All the frequency have been tested and recorded worst frequency(6489.6 MHz) in the report.

Channel 6489.6 MHz-Horizontal

Freq MHz	Measured Level dBuV	Limit Line dBuV/m	Over limit dB	Remark	Pol/Phase
1163.01	19.75	29.54	-9.79	Average	Horizontal
1732.14	31.04	41.54	-10.50	Average	Horizontal
3052.63	28.77	43.54	-14.77	Average	Horizontal
6489.54	48.99	63.54	-14.55	Average	Horizontal
9630.48	46.66	63.54	-16.88	Average	Horizontal
15634.31	30.18	43.54	-13.36	Average	Horizontal

Channel 6489.6MHz-Vertical

Freq MHz	Measured Level dBuV	Limit Line dBuV/m	Over limit dB	Remark	Pol/Phase
1165.52	20.10	29.54	-9.44	Average	Vertical
1734.03	33.04	41.54	-8.50	Average	Vertical
3050.47	31.55	43.54	-11.99	Average	Vertical
6489.54	52.60	63.54	-10.94	Average	Vertical
9633.30	41.86	63.54	-21.68	Average	Vertical
15632.15	32.01	43.54	-11.53	Average	Vertical

Results for Radiated Emissions (at 0.5m for 18 – 40GHz)

Channel 6489.6 MHz

Freq GHz	Measured Level dBuV	Limit Line dBuV/m	Over limit dB	Remark	Pol/Phase
21.65	41.74	49.56	-7.82	Average	Horizontal
28.98	40.07	49.56	-9.49	Average	Horizontal
23.21	39.31	49.56	-10.25	Average	Vertical
31.14	40.38	49.56	-9.18	Average	Vertical

Notes:

- 1). Measuring frequencies from 9 KHz ~ 40 GHz, at least have 20dB margin found between lowest internal used/generated frequency to 30MHz.
- 2). Radiated emissions measured in frequency range from 9 KHz ~ 40 GHz were made with an instrument using average detector mode.
- 3). Data of measurement within this frequency range shown “---” in the table above means the reading of emissions are attenuated more than 20dB below the permissible limits or the field strength is too small to be measured.

Factor = Antenna Factor + Cable Loss - Preamp Factor is considered.





6.3. UWB Bandwidth

6.3.1. Standard Applicable

47 CFR Part 15F Section 15.519 (b);

6.3.2. Limit

A UWB transmitter is defined as an intentional radiator that, at any point in time, has a fractional bandwidth equal or greater than 0.20 or has a UWB bandwidth equal to or greater than 500 MHz, regardless of the fractional bandwidth. The UWB bandwidth is the frequency band bounded by the points that are 10 dB below the highest radiated emission, as based on the complete transmission system including the antenna. The upper boundary is designated f_H and the lower boundary is designated f_L . The frequency at which the highest radiated emission occurs is designated f_M . Center frequency. The center frequency, f_C , equals $(f_H + f_L)/2$. Fractional bandwidth. The fractional bandwidth equals $2(f_H - f_L)/(f_H + f_L)$. Per section 15.519(b), the UWB bandwidth of a UWB system operating under the provisions of this section must be contained between 3100 MHz and 10600 MHz.

6.3.3. Test Procedures

The UWB bandwidth was measured with a spectrum analyzer while the EUT was operating in continuous transmit mode at the appropriate center frequency. The analyzer center frequency was set to the EUT carrier frequency. The analyzer was set to resolution bandwidth of 1 MHz and a video bandwidth of 3 MHz.

6.3.4. Test Setup Layout

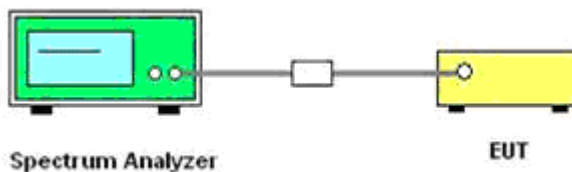

6.3.5. EUT Operation during Test

The EUT was programmed to be in continuously transmitting mode.

6.3.6. Test Result

Temperature	23.5°C	Humidity	52.2%
Test Engineer	Nick Peng	Atmospheric Pressure	1010 mbar





Frequency (GHz)	FL (MHz)	FH (MHz)	10dB Bandwidth(MHz)	Limit (MHz)	Results
3.4944	3290	3695	405.0	3100 MHz -10600 MHz	PASS

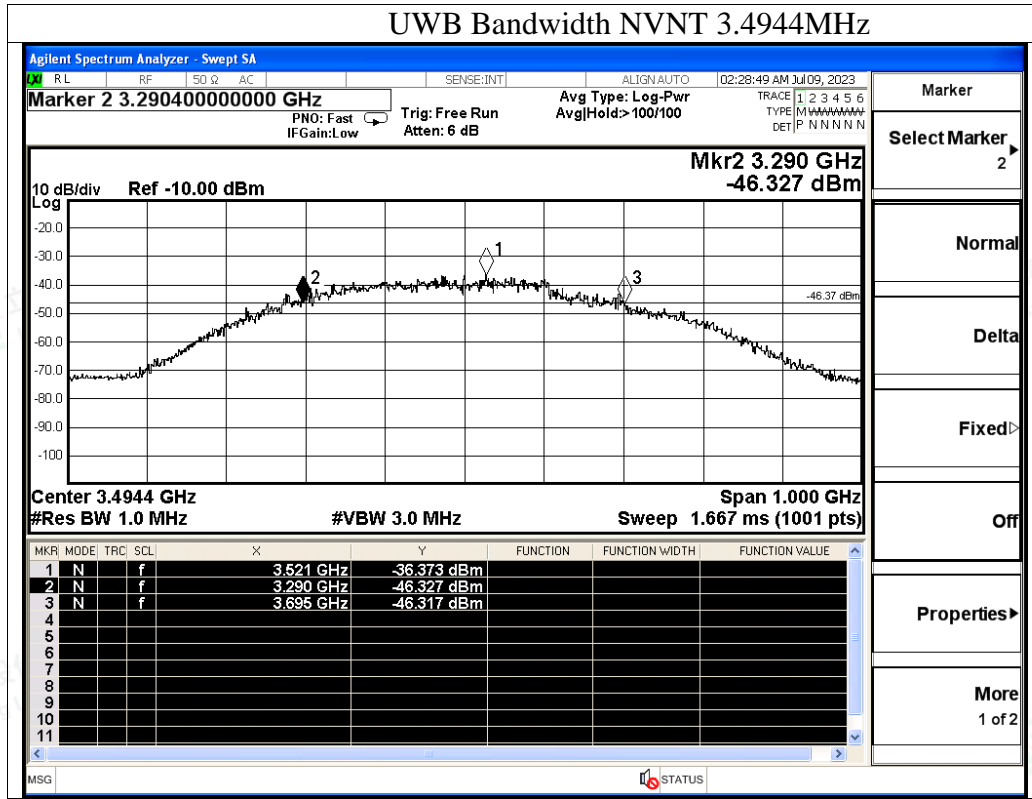



Frequency (GHz)	FL (MHz)	FH (MHz)	10dB Bandwidth(MHz)	Limit (MHz)	Results
3.9936	3764.1	4256.1	492.0	3100 MHz -10600 MHz	PASS

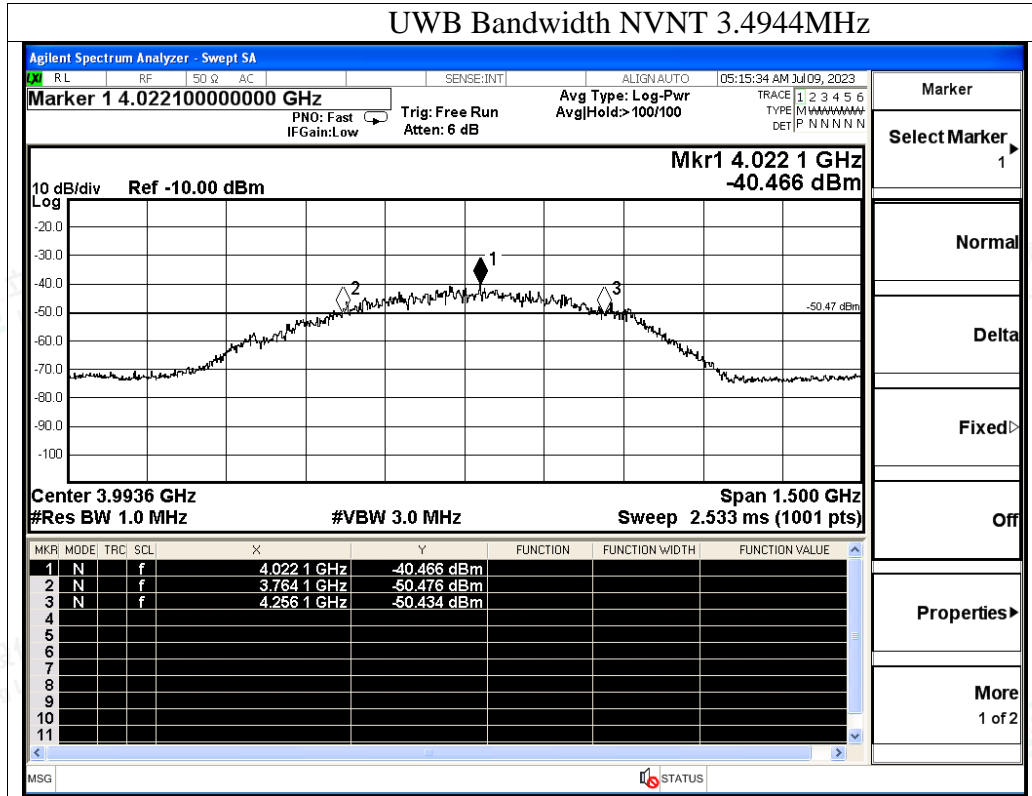

Shenzhen LCS Compliance Testing Laboratory Ltd.
 Add: 101, 201 Bldg A & 301 Bldg C, Juji Industrial Park Yabianxueziwei, Shajing Street, Baoan District, Shenzhen, 518000, China
 Tel: +(86) 0755-82591330 | E-mail: webmaster@lcs-cert.com | Web: www.lcs-cert.com
 Scan code to check authenticity



Frequency (GHz)	FL (MHz)	FH (MHz)	10dB Bandwidth(MHz)	Limit (MHz)	Results
4.4928	4228.8	4809.3	580.5	3100 MHz -10600 MHz	PASS

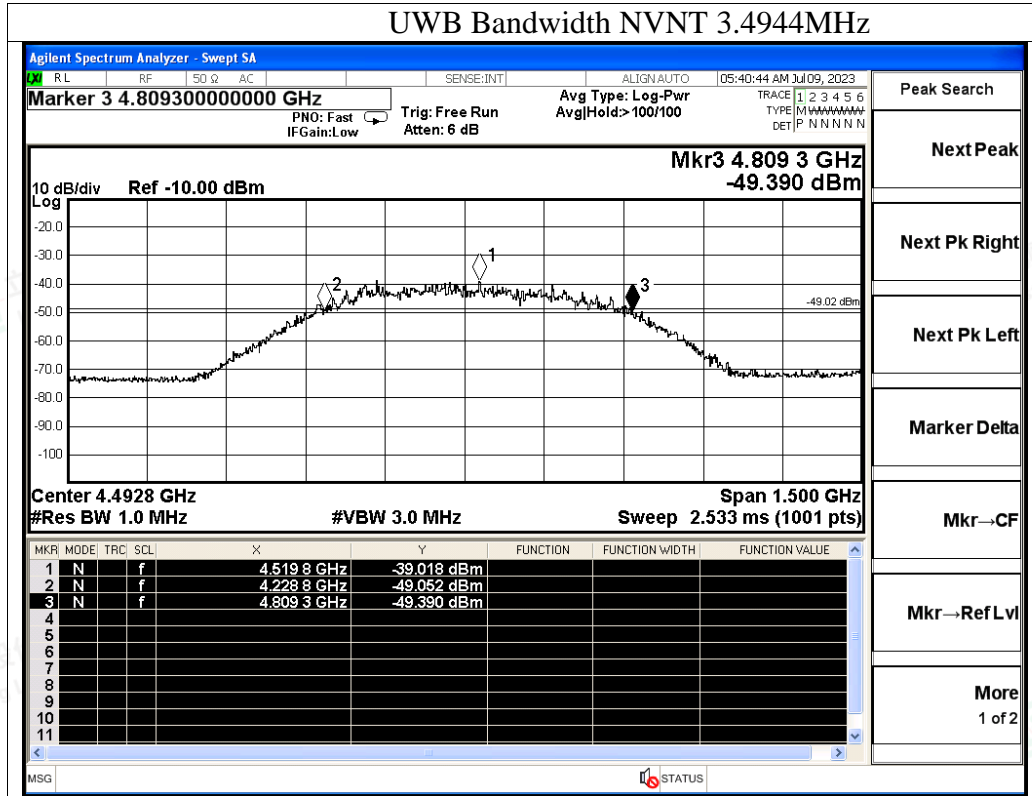



Frequency (GHz)	FL (MHz)	FH (MHz)	10dB Bandwidth(MHz)	Limit (MHz)	Results
6.4896	6368.1	6753.6	385.5	3100 MHz -10600 MHz	PASS

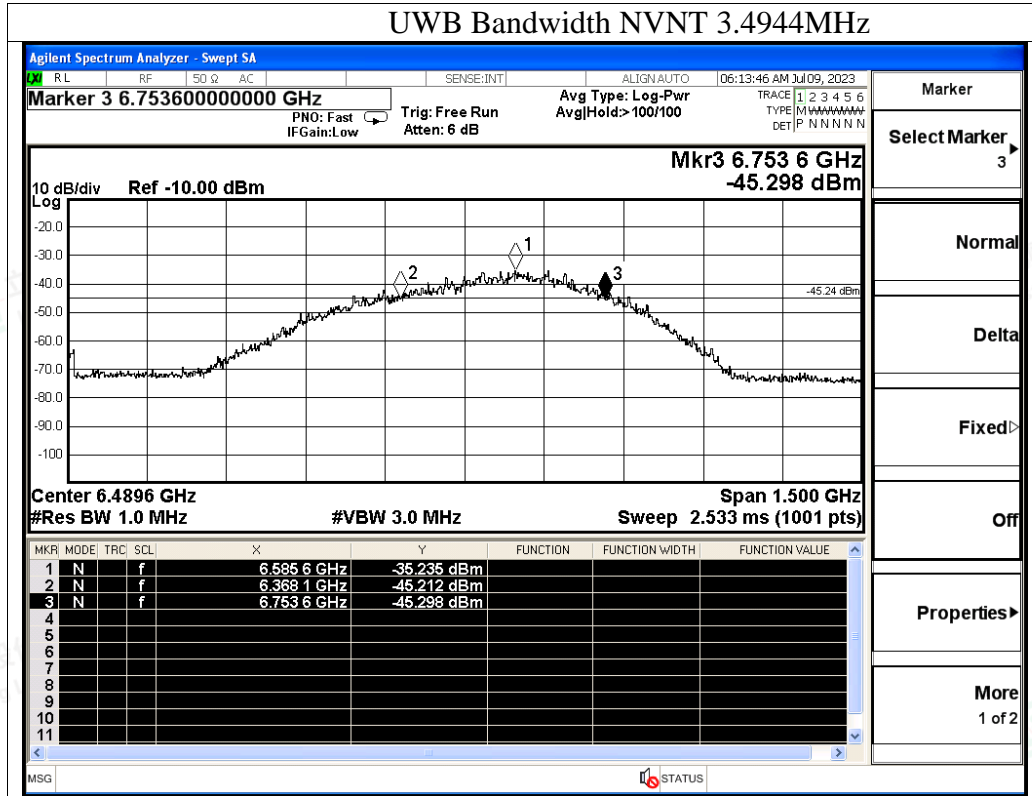

6.4. AC Power Line Conducted Emissions

6.4.1 Standard Applicable

According to §15.207 (a): For an intentional radiator which is designed to be connected to the public utility (AC) power line, the radio frequency voltage that is conducted back onto the AC power line on any frequency or frequencies within the band 150 kHz to 30 MHz shall not exceed 250 microvolts (The limit decreases linearly with the logarithm of the frequency in the range 0.15 MHz to 0.50 MHz). The limits at specific frequency range is listed as follows:

Frequency Range (MHz)	Limits (dBμV)	
	Quasi-peak	Average
0.15 to 0.50	66 to 56	56 to 46
0.50 to 5	56	46
5 to 30	60	50

* Decreasing linearly with the logarithm of the frequency

6.4.2 Block Diagram of Test Setup

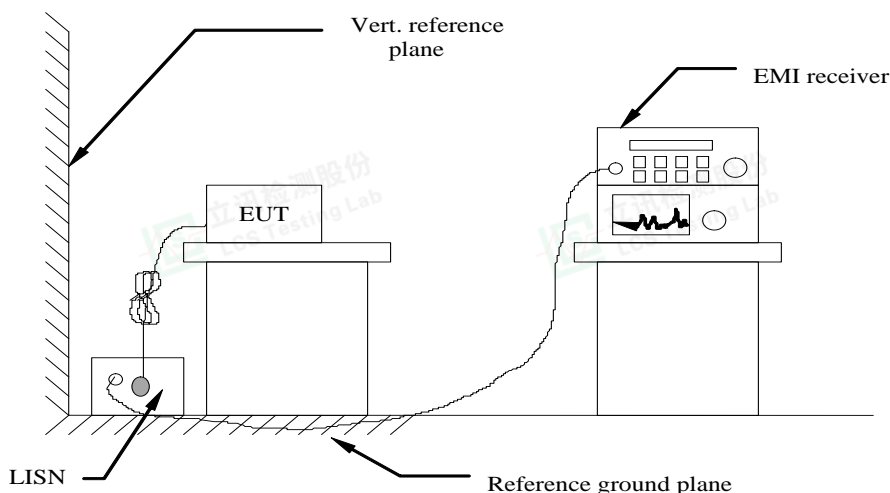

6.4.3 Test Results

PASS.

The test data please refer to following page.

Temperature	24.5°C	Humidity	53.5%
Test Engineer	Nick Peng	Atmospheric Pressure	1010 mbar





AC Conducted Emission @ AC 120V/60Hz (worst case)

Line

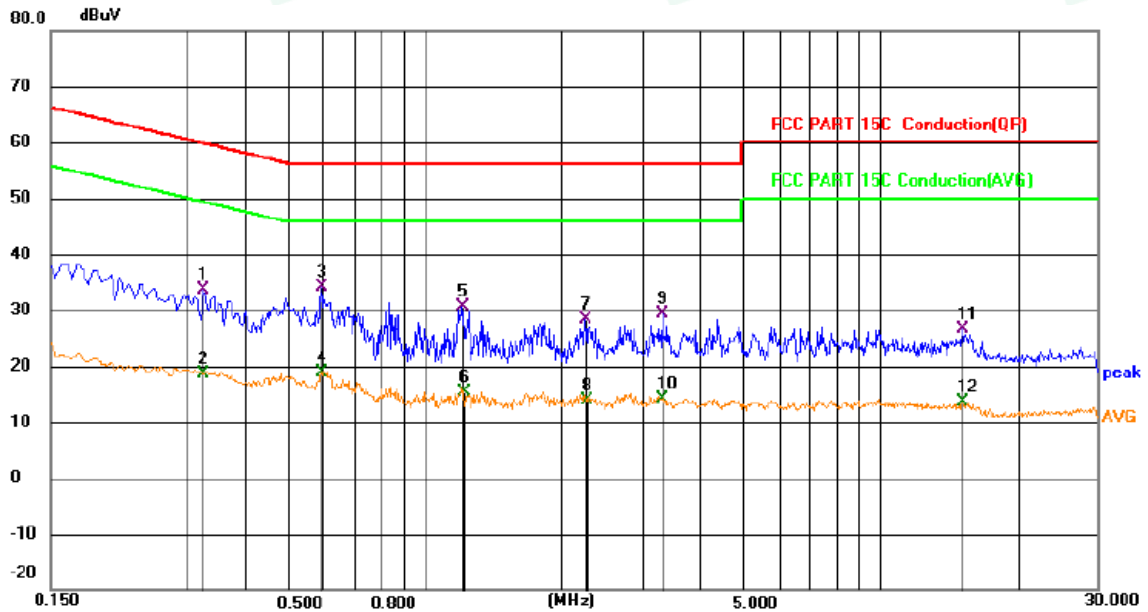

No.	Mk.	Freq.	Reading Level	Correct Factor	Measurement	Limit	Margin	Detector	Comment
		MHz	dBuV	dB	dBuV	dBuV	dB		
1		0.3256	13.89	19.63	33.52	59.56	-26.04	QP	
2		0.3256	-0.97	19.63	18.66	49.56	-30.90	AVG	
3	*	0.5911	14.58	19.66	34.24	56.00	-21.76	QP	
4		0.5916	-0.80	19.66	18.86	46.00	-27.14	AVG	
5		1.2076	10.99	19.66	30.65	56.00	-25.35	QP	
6		1.2121	-4.37	19.66	15.29	46.00	-30.71	AVG	
7		2.2471	8.60	19.68	28.28	56.00	-27.72	QP	
8		2.2516	-5.84	19.68	13.84	46.00	-32.16	AVG	
9		3.3271	9.69	19.70	29.39	56.00	-26.61	QP	
10		3.3271	-5.61	19.70	14.09	46.00	-31.91	AVG	
11		15.1486	6.71	19.88	26.59	60.00	-33.41	QP	
12		15.1486	-6.37	19.88	13.51	50.00	-36.49	AVG	





Neutral

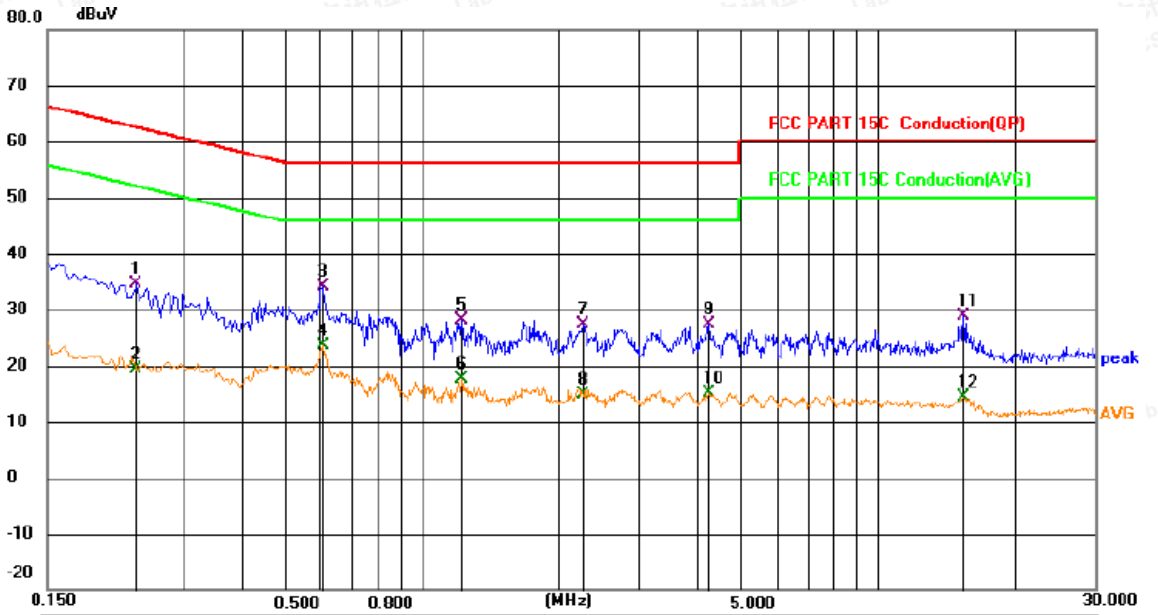

No.	Mk.	Freq.	Reading Level	Correct Factor	Measurement	Limit	Margin	Detector	Comment
		MHz	dBuV	dB	dBuV	dBuV	dB		
1		0.2356	15.06	19.63	34.69	62.25	-27.56	QP	
2		0.2356	-0.33	19.63	19.30	52.25	-32.95	AVG	
3	*	0.6045	14.51	19.66	34.17	56.00	-21.83	QP	
4		0.6045	3.93	19.66	23.59	46.00	-22.41	AVG	
5		1.2210	8.39	19.66	28.05	56.00	-27.95	QP	
6		1.2210	-2.01	19.66	17.65	46.00	-28.35	AVG	
7		2.2559	7.72	19.69	27.41	56.00	-28.59	QP	
8		2.2559	-4.78	19.69	14.91	46.00	-31.09	AVG	
9		4.2495	7.55	19.80	27.35	56.00	-28.65	QP	
10		4.2495	-4.56	19.80	15.24	46.00	-30.76	AVG	
11		15.4366	9.07	19.89	28.96	60.00	-31.04	QP	
12		15.4366	-5.42	19.89	14.47	50.00	-35.53	AVG	

***Note: Pre-scan all modes and recorded the worst case results in this report (UWB-6489.6MHz).
 Measurement = Reading + Correct, Margin = Measurement – Limit.





6.5. Antenna Requirement

6.5.1 Standard Applicable

For intentional device, according to FCC 47 CFR Section 15.203:

An intentional radiator shall be designed to ensure that no antenna other than that furnished by the responsible party shall be used with the device. The use of a permanently attached antenna or of an antenna that uses a unique coupling to the intentional radiator, the manufacturer may design the unit so that a broken antenna can be replaced by the user, but the use of a standard antenna jack or electrical connector is prohibited

And according to FCC 47 CFR Section 15.407 (a), if transmitting antennas of directional gain greater than 6dBi are used, the power shall be reduced by the amount in dB that the directional gain of the antenna exceeds 6dBi.

6.5.2 Antenna Connected Construction

6.5.2.1. Standard Applicable

According to § 15.203 & RSS-Gen, an intentional radiator shall be designed to ensure that no antenna other than that furnished by the responsible party shall be used with the device.

6.5.2.2. Antenna Connector Construction

The gains of antenna used for transmitting is 4.16dBi(Max), and the antenna is Internal Antenna connect to PCB board and no consideration of replacement. Please see EUT photo for details, meet 15.203 & RSS-Gen antenna requirement.



6.6. Peak Emissions within a 50 MHz Bandwidth

6.6.1. Standard Applicable

47 CFR Part 15F Section 15.519 (e);

6.6.2. Limit

There is a limit on the peak level of the emissions contained within a 50 MHz bandwidth centered on the frequency at which the highest radiated emission occurs, fM. That limit is 0 dBm EIRP. The EUT was evaluated to determine compliance with FCC 15.519(e) following the procedures described in FCC Section 15.521.

6.3.3. Test Procedures

The EUT was placed on a non-conductive table 1.5 meters above the ground plane. The table was centered on a rotating turntable at a distance of 1 meter from the measurement antenna. The measurements made over the intentionally radiating frequency range of the EUT, from 3100 MHz to 10600 MHz, were maximized using a spectrum analyzer with peak detector capabilities. A spectrum analyzer was used for the final measurement utilizing a peak detector at the frequency with the largest amplitude. The spectrum analyzer did not support the prescribed resolution bandwidth of 50 MHz. However, when a peak measurement is required, it is acceptable to use a resolution bandwidth other than the 50 MHz specified in 47 CFR Part 15, Subpart F. The resolution bandwidth for the measurement was set to 8 MHz. The measurement was centered on the frequency at which the highest radiated emission occurred, fM. The video bandwidth was 8 MHz. Since a resolution bandwidth other than 50 MHz was used, the peak EIRP limit has to be adjusted by the resolution bandwidth ratio of $20 \log (RBW/50)$ dB, where RBW is the resolution bandwidth used for the measurement expressed in MHz.

6.6.4. Test Setup Layout

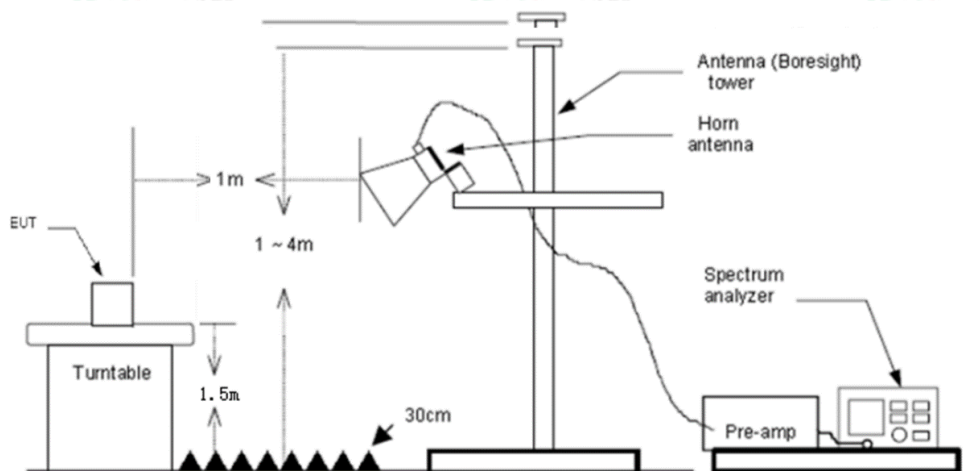

6.6.5. EUT Operation during Test

The EUT was programmed to be in continuously transmitting mode.

6.6.6. Test Result





Temperature	23.8°C	Humidity	52.5%
Test Engineer	Nick Peng	Atmospheric Pressure	1010 mbar

Frequency Range in MHz	EIRP in dBm (within 50 MHz)	calculated Fieldstrength at 3 m in dBμV/m
3100~10600	0	95.3

Frequency Range in MHz	Calculated Fieldstrength at 3m in dBμV/m	EIRP dBm/8MHz (Note1)	EIRP dBm/50MHz (Note2)	Pol/Phase
3494.4MHz	47.29	-48.01	-32.09	Horizontal
3494.4MHz	54.27	-41.03	-25.11	Vertical
3993.6MHz	51.89	-43.41	-27.49	Horizontal
3993.6MHz	52.85	-42.45	-26.53	Vertical
4492.8MHz	50.84	-44.46	-28.54	Horizontal
4492.8MHz	51.20	-44.10	-28.18	Vertical
6489.6MHz	63.87	-31.43	-15.51	Horizontal
6489.6MHz	63.66	-31.64	-15.72	Vertical

Note1:According procedures for measuring **ultra-wideband devices,10.3.9 Determination of EIRP**
 $EIRP(dBm) = E(dBuV/m) - 95.3$ at a specified measurement distance of 3 m

Note 2:According to §15.521(g) If a resolution bandwidth other than 50 MHz is employed, the peak EIRP limit shall be $20 \log(RBW/50)$ dBm where RBW is the resolution bandwidth in megahertz that is employed.

Test Plot as follows

Note: With the reference level offset of -9.54 dB the measurement is referenced to the calculated limit at 3m.





Peak Emissions NVNT 3494.4MHz- Horizontal
Test instrument parameter
RBW/VBW:8MHz/8MHz
Detector Peak
Measurement distance 1.0 m

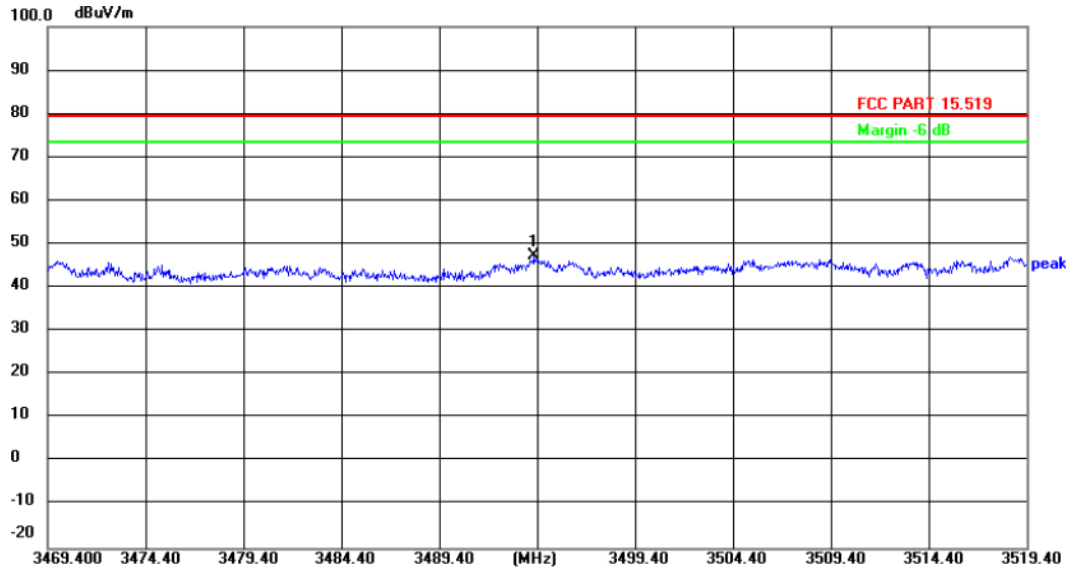

No.	Frequency (MHz)	Reading (dBuV)	Factor (dB/m)	Level (dBuV/m)	Limit (dBuV/m)	Margin (dB)	Detector
1	3494.250	56.70	-9.41	47.29	79.38	-32.09	peak

Peak Emissions NVNT 3494.4MHz- Vertical
Test instrument parameter
RBW/VBW:8MHz/8MHz
Detector Peak
Measurement distance 1.0 m

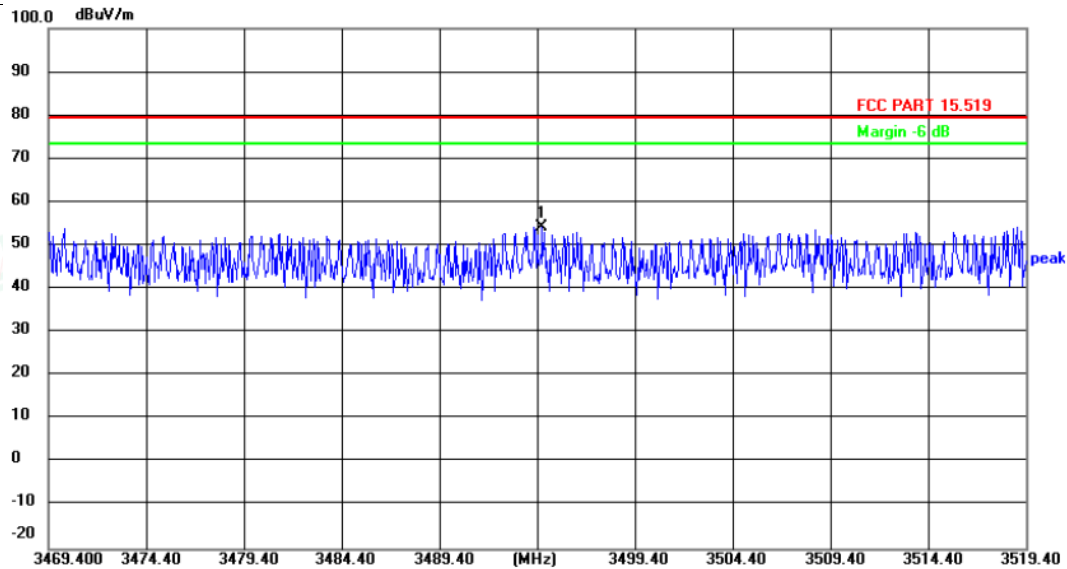

No.	Frequency (MHz)	Reading (dBuV)	Factor (dB/m)	Level (dBuV/m)	Limit (dBuV/m)	Margin (dB)	Detector
1	3494.650	63.68	-9.41	54.27	79.38	-25.11	peak





Peak Emissions NVNT 3993.6MHz- Horizontal
Test instrument parameter
RBW/VBW:8MHz/8MHz
Detector Peak
Measurement distance 1.0 m

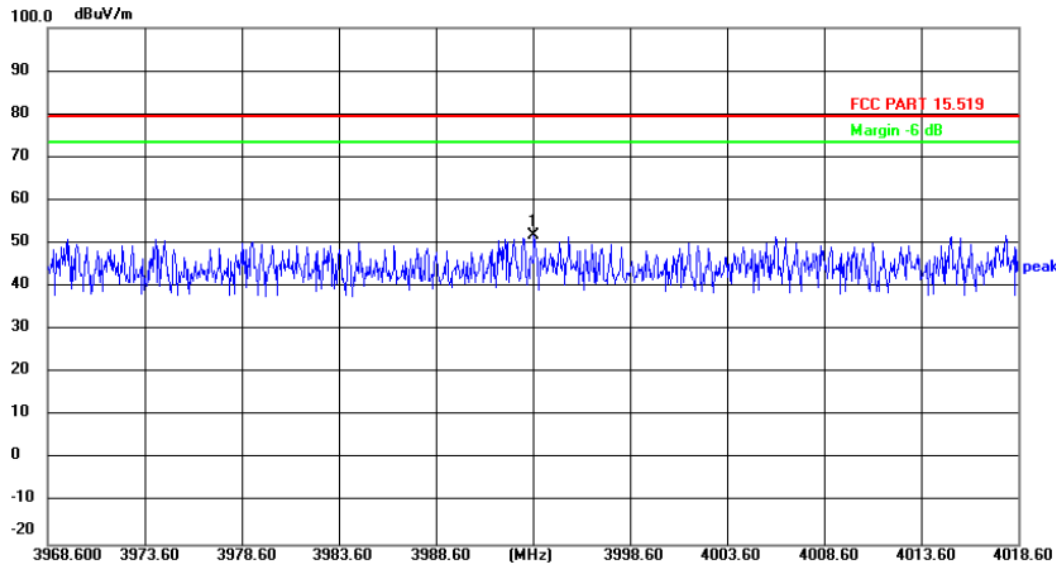

No.	Frequency (MHz)	Reading (dBuV)	Factor (dB/m)	Level (dBuV/m)	Limit (dBuV/m)	Margin (dB)	Detector
1	3993.650	60.44	-8.55	51.89	79.38	-27.49	peak

Peak Emissions NVNT 3993.6MHz- Vertical
Test instrument parameter
RBW/VBW:8MHz/8MHz
Detector Peak
Measurement distance 1.0 m

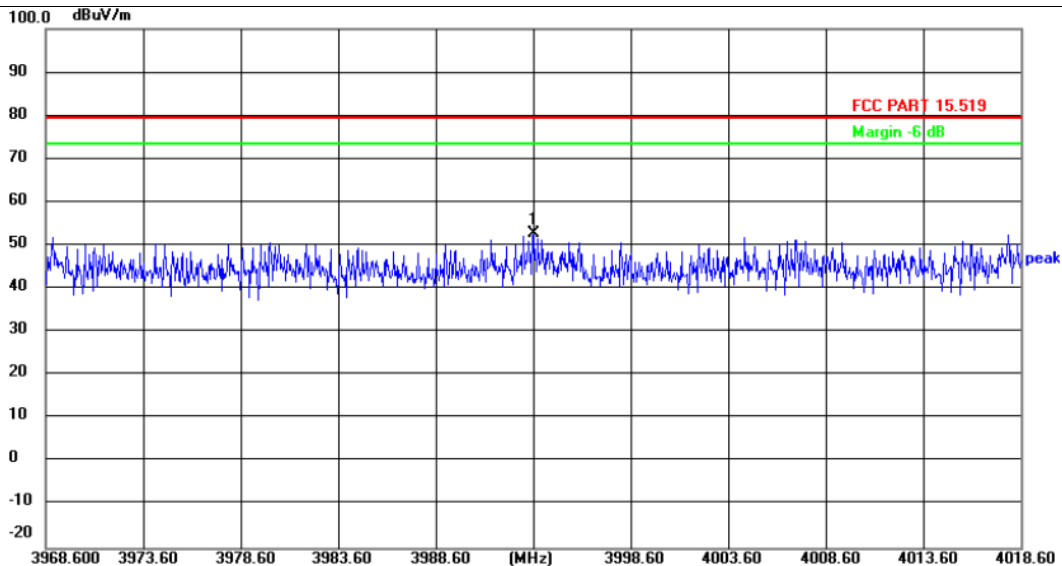

No.	Frequency (MHz)	Reading (dBuV)	Factor (dB/m)	Level (dBuV/m)	Limit (dBuV/m)	Margin (dB)	Detector
1	3993.600	61.40	-8.55	52.85	79.38	-26.53	peak





Peak Emissions NVNT 4492.8MHz- Horizontal
Test instrument parameter
RBW/VBW:8MHz/8MHz
Detector Peak
Measurement distance 1.0 m

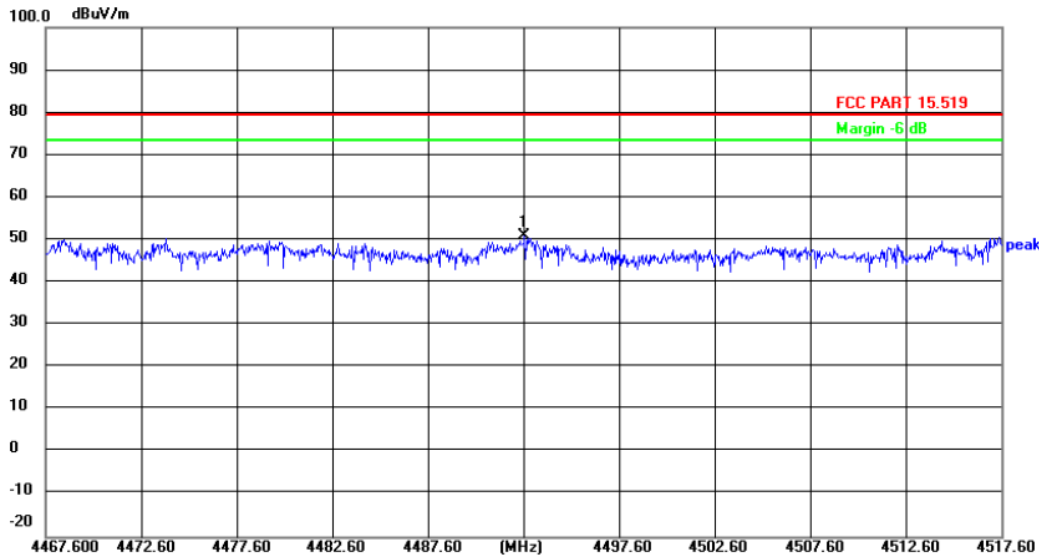

No.	Frequency (MHz)	Reading (dBuV)	Factor (dB/m)	Level (dBuV/m)	Limit (dBuV/m)	Margin (dB)	Detector
1	4492.650	57.45	-6.61	50.84	79.38	-28.54	peak

Peak Emissions NVNT 4492.8MHz- Vertical
Test instrument parameter
RBW/VBW:8MHz/8MHz
Detector Peak
Measurement distance 1.0 m

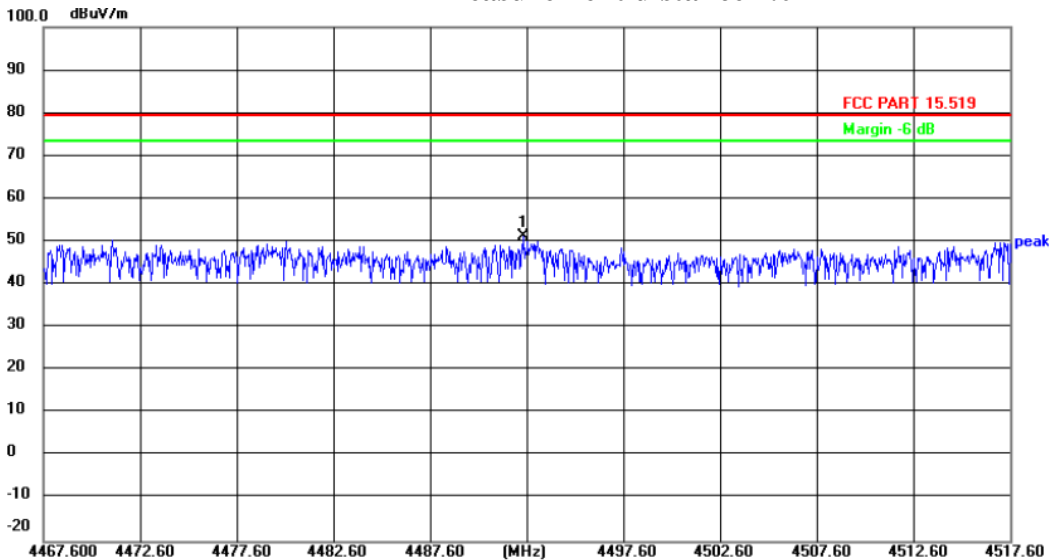

No.	Frequency (MHz)	Reading (dBuV)	Factor (dB/m)	Level (dBuV/m)	Limit (dBuV/m)	Margin (dB)	Detector
1	4492.450	57.81	-6.61	51.20	79.38	-28.18	peak





Peak Emissions NVNT 6489.6MHz- Horizontal
Test instrument parameter
RBW/VBW:8MHz/8MHz
Detector Peak
Measurement distance 1.0 m

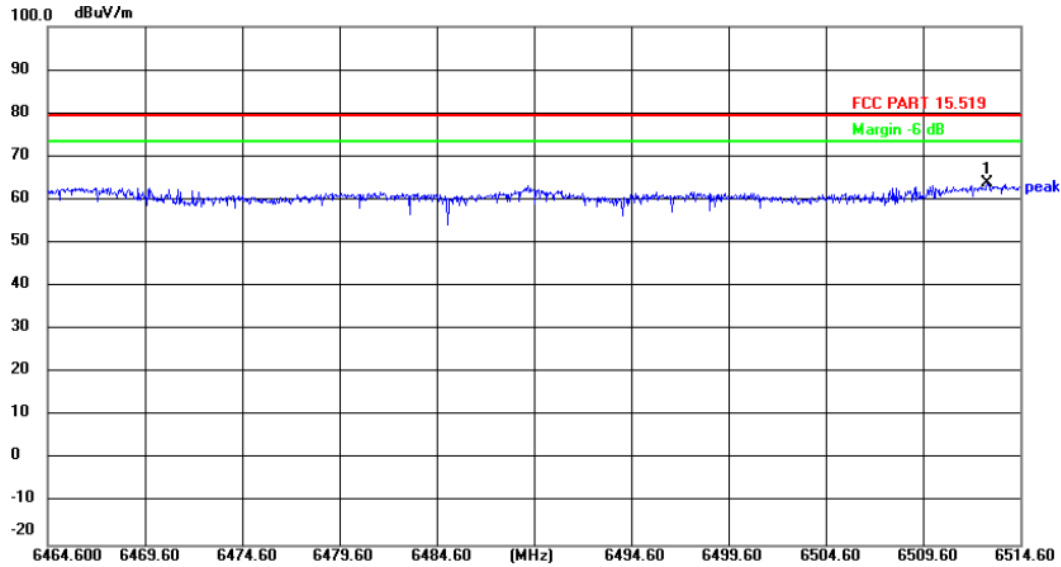

No.	Frequency (MHz)	Reading (dBuV)	Factor (dB/m)	Level (dBuV/m)	Limit (dBuV/m)	Margin (dB)	Detector
1	6512.900	65.28	-1.41	63.87	79.38	-15.51	peak

Peak Emissions NVNT 6489.6MHz- Vertical
Test instrument parameter
RBW/VBW:8MHz/8MHz
Detector Peak
Measurement distance 1.0 m

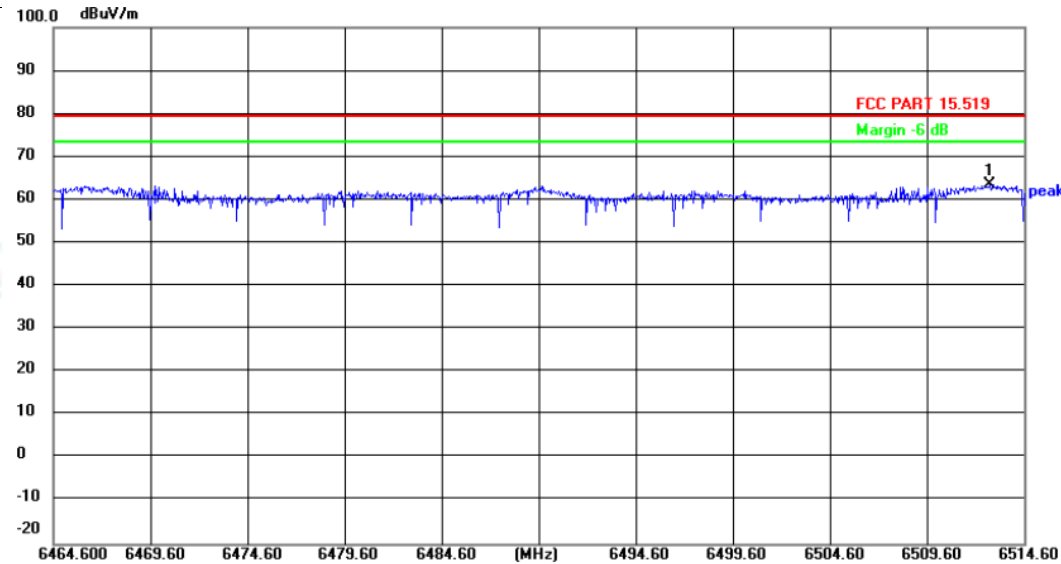

No.	Frequency (MHz)	Reading (dBuV)	Factor (dB/m)	Level (dBuV/m)	Limit (dBuV/m)	Margin (dB)	Detector
1	6512.850	65.07	-1.41	63.66	79.38	-15.72	peak



6.7. Radiated Emissions in GPS Bands

6.7.1. Standard Applicable

47 CFR Part 15F Section 15.519 (d);

6.7.2. Limit

In addition to the radiated emission limits specified in the table in paragraph (c) of this section, UWB transmitters operating under the provisions of this section shall not exceed the following average limits when measured using a resolution bandwidth of no less than 1 kHz:

Frequency in MHz	EIRP in dBm
1164-1240	-85.3
1559-1610	-85.3

Frequency Range in MHz	EIRP in dBm	calculated Fieldstrength at 3 m in dB μ V/m
1164-1240	-85.3	10
1559-1610	-85.3	10

6.3.3. Test Procedures

The EUT was placed on a non-conductive table 1.5 meters above the ground plane. The table was centered on a rotating turntable at a distance of 1 meters from the measurement antenna. The measurements made over the frequency range from 1164 MHz to 1240 MHz and from 1559 MHz to 1610 MHz were maximized using a spectrum analyzer with RMS detector capabilities. A RBW of 10 kHz and VBW of 10 kHz with a suitable averaging time were used for these measurements.

6.7.4. Test Setup Layout

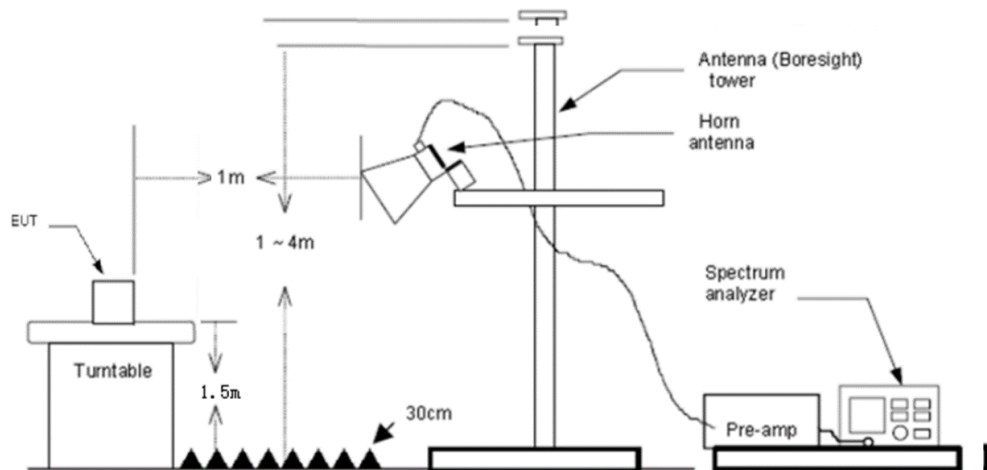

6.7.5. EUT Operation during Test

The EUT was programmed to be in continuously transmitting mode.

6.7.6. Test Result





Temperature	23.5°C	Humidity	52.2%
Test Engineer	Nick Peng	Atmospheric Pressure	1010 mbar

RBW/VBW:10KHz/10KHz

Detector: RMS

Measurement distance:1.0 m

Note: With the reference level offset of -9.54 dB the measurement is referenced to the calculated limit at 3m.

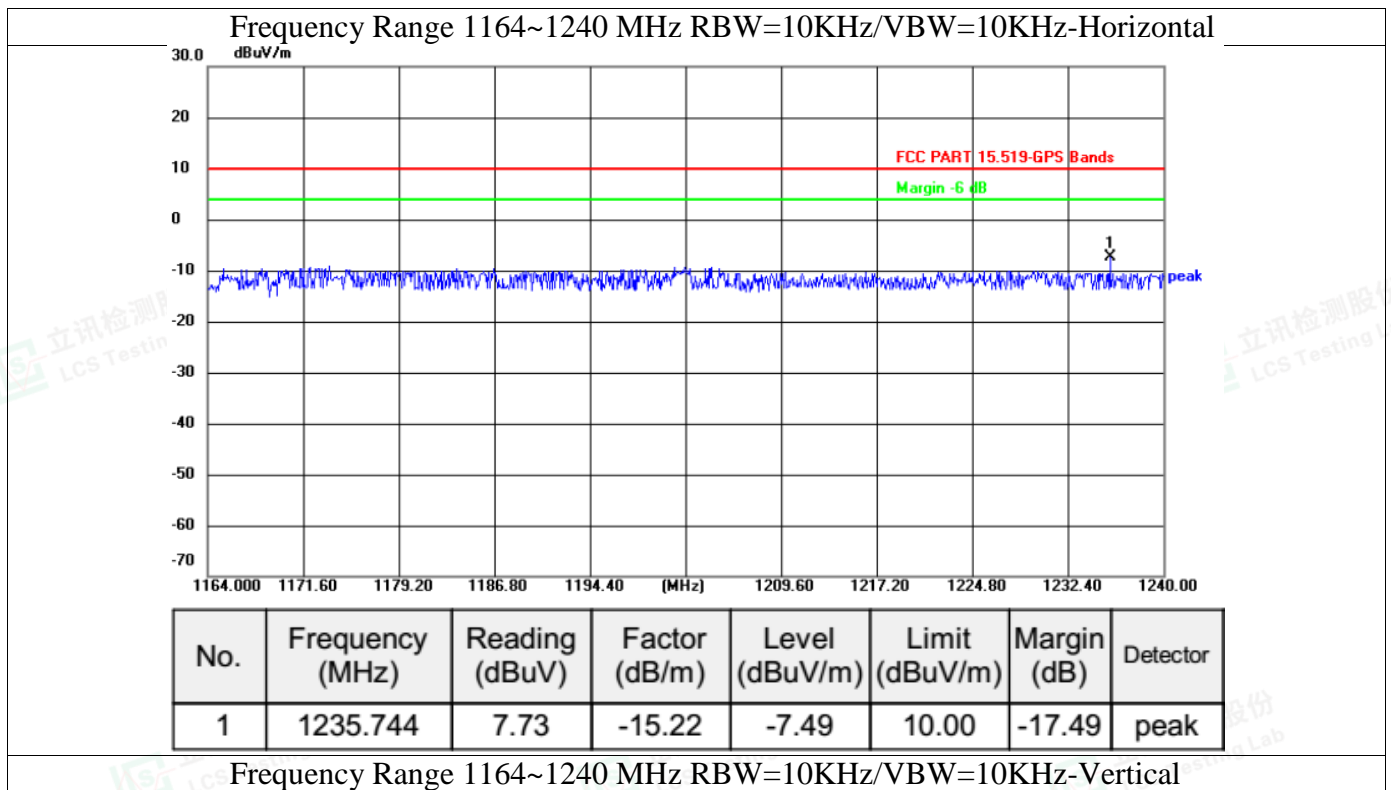

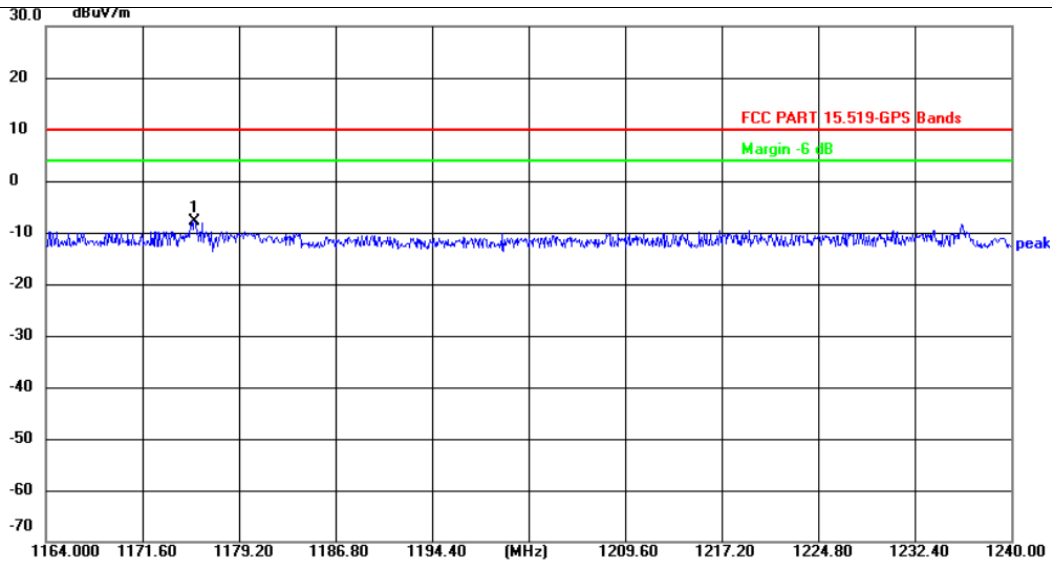

No.	Frequency (MHz)	Reading (dBuV)	Factor (dB/m)	Level (dBuV/m)	Limit (dBuV/m)	Margin (dB)	Detector
1	1175.704	7.35	-15.24	-7.89	10.00	-17.89	peak

Frequency Range 1559~1610MHz RBW=10KHz/VBW=10KHz-Horizontal

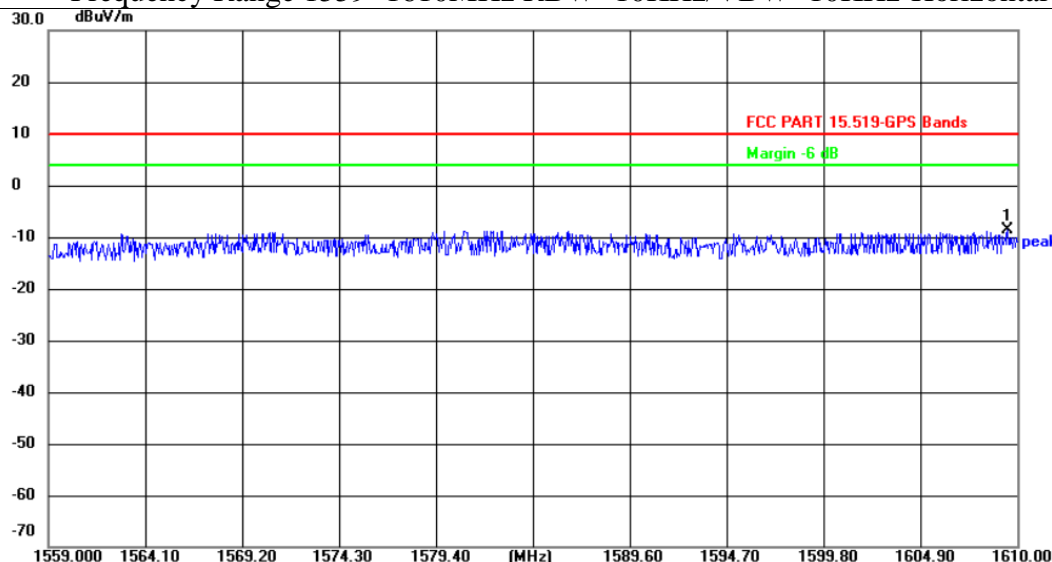

No.	Frequency (MHz)	Reading (dBuV)	Factor (dB/m)	Level (dBuV/m)	Limit (dBuV/m)	Margin (dB)	Detector
1	1609.490	6.08	-14.58	-8.50	10.00	-18.50	peak

Frequency Range 1559~1610MHz RBW=10KHz/VBW=10KHz- Vertical



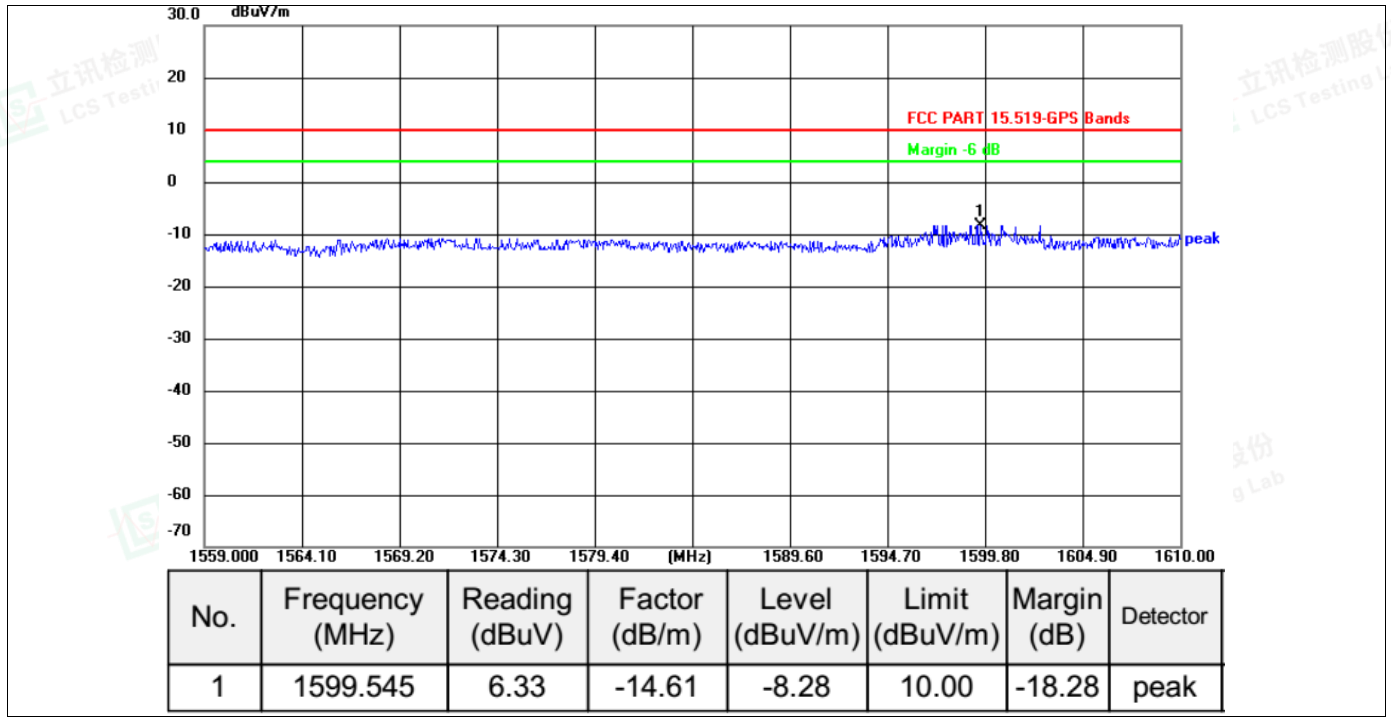

Note: All the frequency have been tested and recorded worst frequency(6489.6 MHz) in the report.



Shenzhen LCS Compliance Testing Laboratory Ltd.
 Add: 101, 201 Bldg A & 301 Bldg C, Juji Industrial Park Yabianxueziwei, Shajing Street, Baoan District, Shenzhen, 518000, China
 Tel: +(86) 0755-82591330 | E-mail: webmaster@lcs-cert.com | Web: www.lcs-cert.com
 Scan code to check authenticity



7. TEST SETUP PHOTOGRAPHS OF EUT

Please refer to separated files for Test Setup Photos of the EUT.

8. EXTERIOR PHOTOGRAPHS OF THE EUT

Please refer to separated files for External Photos of the EUT.

9. INTERIOR PHOTOGRAPHS OF THE EUT

Please refer to separated files for Internal Photos of the EUT.

-----THE END OF TEST REPORT-----

