



TEST REPORT

For

MOBILE PHONE

Model Number: IO Pro

FCC ID: 2AQNZ-IOPRO

IC: 24153-IOPRO

Report Number : WT188005124

Test Laboratory : Shenzhen Academy of Metrology and Quality Inspection
Site Location : NETC Building, No.4 Tongfa Rd., Xili, Nanshan, Shenzhen, China
Tel : 0086-755-86928965
Fax : 0086-755-86009898-31396
Web : www.smq.com.cn
E-mail : emcrf@smq.com.cn

Important statement

1. The academy is a non-profit and legal technical institute authorized by Shenzhen Municipal Government to undertake the quality supervision and inspection of products; provides technical support to relevant supervision administration and also conducts commission test from society.
2. The academy was set up in 1998 through the consolidation of by Shenzhen Institute of Quality Supervision and Testing and Shenzhen Institute of Metrology and Testing.
3. The academy ensures that all testing are carried out scientifically, impartially and accurately, also guarantees the confidential of the samples and the technical documents.
4. The sampling should be carried out according to the "sampling procedure" in the Procedure Document CX22-01 and the stipulation of the inspection rules.
5. Any reports without the signature, or audited, or without the special seal are considered invalidated. Copying or using select parts, or tampering with this document without the permission of our academy is forbidden.
6. The results of the commission test are only valid to the submitted samples. The sample information and the client information are provided by the applicant. The academy is not responsible for the integrity of the sample and its accuracy of identification information.
7. Applicant is not allowed to propagate with the test result without the agreement of the test institution.
8. The report without CMA logo of SMQ is only for the use of internal reference and does not have a role of proof in society. CAL symbol with the serial number of Guangdong are only applicable to product standards and decision standards.
9. Any objections to the report should be submitted in 15 days since the issuing of the report. Any objections to the results of agricultural products supervision and inspection should be applied for re-test within 5 days since receiving inspection report to administrative department of agriculture which organize and implement agricultural products supervision and inspection or its higher level of agricultural administrative department. Any objections to the report of food supervision and inspection should be applied for re-test within 7 days since receiving inspection report to the food and drug administrative department which implement sampling inspection or its higher level of food and drug administrative department.
10. The electronic certificate/report shall not be recalled after alteration. The applicant is responsible to supply the altered certificate/report to the related party using the original certificate/report.

Establishment of following institutions

National Hi-tech Metrology Station

National Digital Electronic Product Testing Center (NETC)

National Sports Product Testing Center (Guangdong)

National Urban Energy Measurement Center (Shenzhen)

National Nutritional Food Quality and Inspection Center (Guangdong)

Accredited Testing Station (Shenzhen) for Furniture by China National Light Industry Council (CNLIC)

Guangdong Quality Supervision and Inspection Institution for Furniture Products

Guangdong Quality Supervision and Inspection Institution for Food (Shenzhen)

Guangdong Quality Supervision and Inspection Institution for Generic Cabling System

Guangdong Quality Supervision and Inspection Institution for Bicycle Quality

Guangdong Quality Supervision and Inspection Institution for Electromagnetic Compatibility

Guangdong Quality Supervision and Inspection Institution for Leather Products

Guangdong Quality Supervision and Inspection Institution for Ecological Textile and Garment Products (Shenzhen)

Guangdong Quality Supervision and Inspection Institution for Horological Products (Shenzhen)

Guangdong Quality Supervision and Inspection Institution for Safety Performance of Environmental Protection and Energy Saving Products (Shenzhen)

Guangdong Quality Supervision and Inspection Institution for Student's Articles (Shenzhen)

Guangdong Quality Supervision and Inspection Institution for Eyewear Products (Shenzhen)

Shenzhen Quality Inspection Institution for Fiber and Textile

Shenzhen Quality Supervision and Inspection Institution for Building Materials

Shenzhen Testing Center for Burning Behavior of Fire Protection Products

Business contact information

Textile and Light Industrial Products Test

Tel: 0755-27528868

Fax: 0755-27528516

National Digital Electronic Product Testing Center (NETC)

Tel: 0755-86928963

Fax: 0755-86009898-31339

Catering Food Test

Tel: 0755-27528977

Fax: 0755-27528916

Chemical Products Test

Tel: 0755-27528987

Fax: 0755-27528479

Fire Protection Products Testing Center

Tel: 0755-89325252

Fax: 0755-89325282

Building Materials and Household Products Test

Tel: 0755-26002957

Fax: 0755-26001771

0755-27528884

0755-27528711

Complaint

Tel: 0755-26941613 (Longzhu)

0755-27528392 (Longhua)



TABLE OF CONTENTS

TEST REPORT DECLARATION	2
1. TEST RESULTS SUMMARY	4
2. GENERAL INFORMATION	5
2.1. Report information.....	5
2.2. Laboratory Accreditation and Relationship to Customer	5
2.3. Measurement Uncertainty.....	6
3. PRODUCT DESCRIPTION	7
3.1. EUT Description	7
3.2. Related Submittal(s) / Grant (s)	8
3.3. Block Diagram of EUT Configuration	8
3.4. Operating Condition of EUT	8
3.5. Support Equipment List.....	12
3.6. Test Conditions.....	12
3.7. Special Accessories.....	12
3.8. Equipment Modifications.....	12
4. TEST EQUIPMENT USED	13
5. TEST RESULTS	14
5.1. RF Power Output.....	14
5.2. Peak to Average Ratio	17
5.3. Occupied Bandwidth/Emission Bandwidth.....	25
5.4. Spurious Emission at Antenna Terminal	38
5.5. Spurious Emissions Radiated	56
5.6. Frequency Stability.....	61



1. TEST RESULTS SUMMARY

Table 1 Test Results Summary

FCC Part(s)	IC Part(s)	Description	Result
2.1046 22.913 24.232 90.205 90.635	RSS-132§5.4 RSS-133§6.8 RSS-119§5.4	Effective Radiated Power of Transmitter	PASS
2.1046 24.232(d)	RSS-132§5.4 RSS-133§6.8	Peak to Average Ratio	PASS
2.1049 22.917(b) 24.238(b) 90.209	RSS-132 RSS-133§2.3 RSS-119§5.5	Occupied Bandwidth	PASS
2.1051 22.917 24.238 90.669	RSS-132§5.5 RSS-133§6.5 RSS-119§5.8	Spurious Emission at Antenna Terminal	PASS
2.1053 22.917 24.238 90.210	RSS-132§5.5 RSS-133§6.5 RSS-119§5.8	Radiated Spurious Emissions	PASS
2.1055 22.355 24.235 90.213	RSS-132§5.3 RSS-133§6.3 RSS-119§5.3	Frequency Stability	PASS

Remark: "N/A" means "Not applicable."

The tests documented in this report were performed in accordance with ANSI C63.26 (2015), FCC CFR 47 Part 2, FCC CFR 47 Part 22, Part 24, Part 90 and IC RSS-132, RSS-133, RSS-119



2. GENERAL INFORMATION

2.1. Report information

This report is not a certificate of quality; it only applies to the sample of the specific product/equipment given at the time of its testing. The results are not used to indicate or imply that they are application to the similar items. In addition, such results must not be used to indicate or imply that SMQ approves recommends or endorses the manufacture, supplier or use of such product/equipment, or that SMQ in any way guarantees the later performance of the product/equipment.

The samples mentioned in this report is/are supplied by Applicant, SMQ therefore assumes no responsibility for the accuracy of information on the brand name, model number, origin of manufacture or any information supplied.

Additional copies of the report are available to the Applicant at an additional fee. No third part can obtain a copy of this report through SMQ, unless the applicant has authorized SMQ in writing to do so.

2.2. Laboratory Accreditation and Relationship to Customer

The testing report were performed by the Shenzhen Academy of Metrology and The testing report were performed by the Shenzhen Academy of Metrology and quality Inspection EMC Laboratory (Guangdong EMC compliance testing center), in their facilities located at NETC Building, No.4 Tongfa Rd., Xili, Nanshan, Shenzhen, China. At the time of testing, Laboratory is accredited by the following organizations:

China National Accreditation Service for Conformity Assessment (CNAS) accredits the Laboratory for conformance to FCC standards, EMC international standards and EN standards. The Registration Number is CNAS L0579.

The Laboratory is Accredited Testing Laboratory of FCC with Designation number CN1165 and Site registration number 582918.

The Laboratory is registered to perform emission tests with Industry Canada (IC), and the registration number is 11177A.

TUV Rhineland accredits the Laboratory for conformance to IEC and EN standards, the registration number is E2024086Z02.



2.3. Measurement Uncertainty

For a 95% confidence level ($k = 2$), the measurement expanded uncertainties for defined systems, in accordance with the recommendations of ISO 17025 as following:

Radiated Emission

30MHz~1000MHz 4.5dB

1GHz~26.5GHz 4.6dB

26dB & Occupied Bandwidth: $\pm 0.39\%$

Frequency Stability: $\pm 0.42\%$

Peak to Average Ratio: 0.45 dB

Conducted power : 0.3 dB

Temperature: ± 0.698

Supply voltages: $\pm 0.15\%$



3. PRODUCT DESCRIPTION

3.1. EUT Description

Table 2 Specification of the Equipment under Test

Product Type:	MOBILE PHONE
Hardware Revision :	V0(manufacturer declare)
Software Revision :	MOLY.LR12A.R2.MP.V36.9(manufacturer declare)
FCC-ID:	2AQNZ-IOPRO
IC:	24153-IOPRO
Frequency:	CDMA BC0: TX 824MHz~849MHz RX 869MHz~894MHz CDMA BC1: TX 1850MHZ~1910MHZ RX 1930MHZ~1990MHZ CDMA BC10: TX 816MHz~824MHz RX 861MHz~869MHz
Type(s) of Modulation:	CDMA: QPSK
Antenna Type:	MONOPOLE Typical gain: -5dBi
Operating voltage:	Internal battery, 120V AC Adapter; 3.5V (Low)/3.8V (Nominal)/ 4.2V (Max)

Table 3 Identification of the Equipment Under Test (EUT)

EUT	Serial Number/IMEI	HW Version	SW Version	Notes
1	86887203011959	V0(manufacturer declare)	MOLY.LR12A.R2 .MP.V36.9(manufacturer declare)	Conducted testing sample.
2.	868872030005352	V0(manufacturer declare)	MOLY.LR12A.R2 .MP.V36.9(manufacturer declare)	Conducted testing sample.
3	868872030132354	V0(manufacturer declare)	MOLY.LR12A.R2 .MP.V36.9(manufacturer declare)	Radiated testing sample.

Table 4 Identification of Accessory equipment

AE #	Type	Manufacturer	Model	Serial Number
--	--	--	--	--

3.2. Related Submittal(s) / Grant (s)

This submittal(s) (test report) is intended for FCC ID: 2AQNZ-IOPRO filing to comply with FCC PART 22H, 24E, 90S and IC: filing to comply with IC RSS-132 Issue 3, RSS-133 Issue 6, RSS-119 Issue 12.

3.3. Block Diagram of EUT Configuration

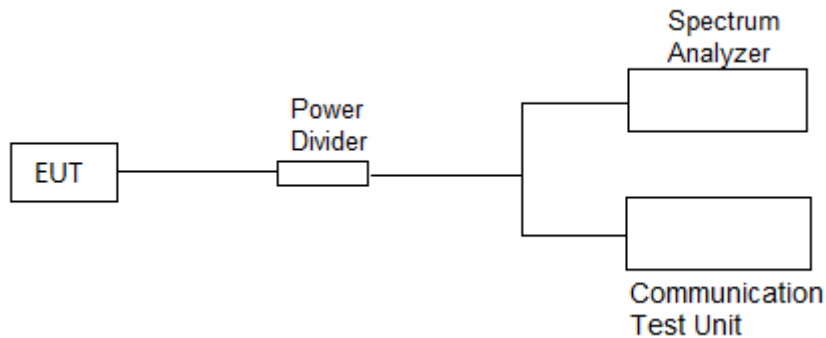

Figure 1 EUT setup of test mode 1&2

3.4. Operating Condition of EUT

During all testing, EUT is in link mode with base station emulator at maximum power level. The spurious emission measurements were carried out in semi-anechoic chamber with 3-meter test range, and EUT is rotated on three test planes to find out the worst emission (X plane).

TM1: 1xRTT RC2 SO9

TM2: 1xEV-DO Release 0

The maximum power levels are RC2 SO9 mode for 1xRTT, Release 0 mode for 1xEV-DO, only these modes were used for all tests.



The conducted power tables are as follows:

RF Power Output for 1xRTT – BC10 SECONDARY 800				
Radio Configuration (RC)	Service Option(SO)	Conducted Output Power (dBm)		
		Ch. 450/ 817.25MHz	Ch. 560/ 820MHz	Ch. 670/ 822.75 MHz
		Average	Average	Average
RC1	2(Loopback)	20.17	20.05	20.08
	55 (Loopback)	20.11	20.11	20.09
RC2	9(Loopback)	20.22	20.23	20.14
	55 (Loopback)	20.18	20.10	20.06
RC3	2(Loopback)	20.21	21.14	20.08
	55 (Loopback)	20.22	20.13	20.08
	32 (+F-SCH)	20.19	20.11	20.15
	32 (+SCH)	20.17	20.09	20.08
RC4	2(Loopback)	20.14	20.13	20.13
	55 (Loopback)	20.21	20.13	20.10
	32 (+F-SCH)	20.17	20.15	20.12
	32 (+SCH)	20.15	20.13	20.11
RC5	9(Loopback)	20.13	20.12	20.13
	55 (Loopback)	20.12	20.13	20.08
RC11	2(Loopback)	20.12	20.13	20.16
	75 (Loopback)	20.16	20.14	20.13
	32 (+F-SCH)	20.16	20.18	20.15
	32 (+SCH)	20.13	20.15	20.09

RF Power Output for 1xRTT – BC0 CELL Band				
Radio Configuration (RC)	Service Option(SO)	Conducted Output Power (dBm)		
		Ch. 1013/ 824.7MHz	Ch. 384/ 836.52MHz	Ch. 777/ 848.31 MHz
		Average	Average	Average
RC1	2(Loopback)	22.30	22.39	22.36
	55 (Loopback)	22.36	22.46	22.32
RC2	9(Loopback)	22.37	22.56	22.42
	55 (Loopback)	22.32	22.45	22.31
RC3	2(Loopback)	22.32	22.50	22.43
	55 (Loopback)	22.37	22.50	22.35
	32 (+F-SCH)	22.35	22.47	22.39
	32 (+SCH)	22.37	22.50	22.38
RC4	2(Loopback)	22.30	22.49	22.42
	55 (Loopback)	22.30	22.50	22.35
	32 (+F-SCH)	22.28	22.46	22.31
	32 (+SCH)	22.31	22.49	22.34
RC5	9(Loopback)	22.29	22.49	22.38
	55 (Loopback)	22.41	22.50	22.35
RC11	2(Loopback)	22.33	22.46	22.36
	75 (Loopback)	22.36	22.49	22.33
	32 (+F-SCH)	22.31	22.47	22.32
	32 (+SCH)	22.33	22.45	22.34



RF Power Output for 1xRTT – BC1 PCS Band				
Radio Configuration (RC)	Service Option(SO)	Conducted Output Power (dBm)		
		Ch. 25/ 1851.25MHz	Ch. 600/ 1880MHz	Ch. 1175/ 1908.75 MHz
		Average	Average	Average
RC1	2(Loopback)	24.81	24.67	24.69
	55 (Loopback)	24.86	24.65	24.64
RC2	9(Loopback)	24.96	24.74	24.72
	55 (Loopback)	24.78	24.63	24.66
RC3	2(Loopback)	24.87	24.67	24.64
	55 (Loopback)	24.81	24.68	24.70
	32 (+F-SCH)	24.79	24.66	24.65
	32 (+SCH)	24.80	24.62	24.61
RC4	2(Loopback)	24.88	24.71	24.62
	55 (Loopback)	24.85	24.71	24.74
	32 (+F-SCH)	24.85	24.68	24.65
	32 (+SCH)	24.87	24.72	24.67
RC5	9(Loopback)	24.92	24.69	24.62
	55 (Loopback)	24.82	24.70	24.72
RC11	2(Loopback)	24.87	24.69	24.73
	75 (Loopback)	24.85	24.74	24.65
	32 (+F-SCH)	24.81	24.72	24.69
	32 (+SCH)	24.84	24.73	24.71

RF Power Output for 1xEV-DO – BC10 SECONDARY 800				
Release	FETAP - Traffic Forma	Conducted Output Power (dBm)		
		Ch. 450/ 817.25MHz	Ch. 560/ 820MHz	Ch. 670/ 822.75 MHz
		Average	Average	Average
Release 0	307.2k QPSK/ ACK channel is transmitted at all the slots	20.25	20.16	20.14
Release A	307.2k QPSK/ ACK channel is transmitted at all the slots	20.21	20.21	20.13

RF Power Output for 1xEV-DO –BC0 CELL Band				
Release	FETAP - Traffic Forma	Conducted Output Power (dBm)		
		Ch. 1013/ 824.7MHz	Ch. 384/ 836.52MHz	Ch. 777/ 848.31 MHz
		Average	Average	Average
Release 0	307.2k QPSK/ ACK channel is transmitted at all the slots	22.28	22.39	22.42
Release A	307.2k QPSK/ ACK channel is transmitted at all the slots	22.25	22.34	22.44



RF Power Output for 1xEV-DO REV0-BC1 PCS Band				
Release	FETAP - Traffic Forma	Conducted Output Power (dBm)		
		Ch. 25/ 1851.25MHz	Ch. 600/ 1880MHz	Ch. 1175/ 1908.75 MHz
		Average	Average	Average
Release 0	307.2k QPSK/ ACK channel is transmitted at all the slots	24.52	24.23	24.51
Release A	307.2k QPSK/ ACK channel is transmitted at all the slots	24.51	24.17	24.49



3.5. Support Equipment List

Table 5 Support Equipment List

Name	Model No	S/N	Manufacturer
--	--	--	--

3.6. Test Conditions

Date of test : Sep.01, 2018 – Oct.08, 2018

Date of EUT Receive : Aug.28, 2018

Temperature: -30~55 °C

Relative Humidity: 42~60%

3.7. Special Accessories

Not available for this EUT intended for grant.

3.8. Equipment Modifications

Not available for this EUT intended for grant.

4. TEST EQUIPMENT USED

Table 6 Test Equipment

No.	Equipment	Manufacturer	Model No.	Last Cal.	Cal. Interval
SB8501/09	EMI Test Receiver	Rohde & Schwarz	ESU40	Mar.20, 2018	1 Year
SB5472/02	Bilog Antenna	Schwarzbeck	VULB9163	Jun.12, 2018	1 Year
SB3435	Horn Antenna	Rohde & Schwarz	HF906	Jan.02, 2018	1 Year
SB8501/10	Horn Antenna	ETS-Lindgren	3160-09	Mar.21,2017	3 Year
SB8501/14	Preamplifier	Rohde & Schwarz	SCU-03	Mar.08, 2018	1 Year
SB8501/16	Preamplifier	Rohde & Schwarz	SCU-26	Mar.05, 2018	1 Year
SB8501/17	Preamplifier	Rohde & Schwarz	SCU-18	Mar.05, 2018	1 Year
SB8501/02	Communication Test Unit	Rohde & Schwarz	CMU200	Dec.04, 2017	1 Year
SB9721/01	Communication Test Unit	Agilent	E5515C	Dec.04, 2017	1 Year
SB9060	Signal Analyzer	Rohde & Schwarz	FSQ40	Feb.27,2018	1 Year
SB12724/01	Signal Analyzer	Rohde & Schwarz	FSW26	Jun.06,2018	1 Year
SB11818	Temperature&Humidity Test chamber	EH-010U	Espec	Mar.27, 2018	1 Year
SB9721/07	DC Power Supply	Agilent	66319D	---	---
---	Power Divider	Agilent	87302C	---	---
--	Test software	Rohde & Schwarz	EMC 32 8.50.0	--	--
--	Filter, HPF 1.2GHz	Mini-Circuits	VHF-1200+	--	--
--	Filter, HPF 3.0GHz	Wainwright Instruments GmbH	WHK3.0/18G-10 FE	--	--
--	Radiated Cable Set	Huber+Suhner	W22.01 AP5 X1	--	--
--	Radiated Cable Set	Huber+Suhner	W22.01 AP5 X1	--	--
--	Radiated Cable Set	Huber+Suhner	W11.20 CBL6112	--	--
--	Radiated Cable Set	Huber+Suhner	W11.20 CBL6112	--	--
--	Radiated Cable Set	Huber+Suhner	SUCOFLEX 100	--	--
--	Conducted Cable Set	Huber+Suhner	SUCOFLEX 104	--	--
--	Conducted Cable Set	Huber+Suhner	SUCOFLEX 104	--	--



5. TEST RESULTS

5.1. RF Power Output

5.1.1. Test Standard

FCC: CFR Part 2.1046, CFR Part 22.913, CFR Part 24.232, CFR Part 90.

IC : RSS-132§5.4, RSS-133§6.4, RSS-119

5.1.2. Test Limit

FCC 22.913 (a) Effective radiated power limits.

The effective radiated power (ERP) of mobile transmitters must not exceed 7 Watts.

FCC 24.232 (b)(c) Power limits.

(b) Mobile/portable stations are limited to 2 Watts effective isotropic radiated power (EIRP). (c) Peak transmit power must be measured over any interval of continuous transmission using instrumentation calibrated in terms of an rms equivalent voltage. The measurement results shall be properly adjusted for any limitations, such as detector response times, limited resolution bandwidth capability when compared to the emission bandwidth, sensitivity, etc., so as to obtain a true peak measurement over the full bandwidth of the channel.

FCC 90.635 (b) Power limits.

The maximum output power of the transmitter for mobile stations is 100 watts (20 dBw).

RSS-132§5.4:

The transmitter output power shall be measured in terms of average power. The equivalent isotropically radiated power (e.i.r.p.) for mobile equipment shall not exceed 11.5 watts.

RSS-133§6.4:

Mobile stations and hand-held portables are limited to 2 watts maximum e.i.r.p. The equipment shall employ means to limit the power to the minimum necessary for successful communication.

RSS-119§5.4:

The maximum output power of the transmitter for Frequency Bands (806-821/851-866 and 821-824/866-869) Mobile Equipment is 30 watts .

5.1.3. Test Procedure

ANSI C63.26:2015

KDB 971168 Section 5.6

$ERP/EIRP = P_{Meas} + GT - LC$

where: ERP/EIRP = effective or equivalent radiated power, respectively (expressed in the same

units as P_{Meas}, typically dBW or dBm);

P_{Meas} = measured transmitter output power or PSD, in dBm or dBW;

GT = gain of the transmitting antenna, in dBd (ERP) or dBi (EIRP);

LC = signal attenuation in the connecting cable between the transmitter and antenna, in dB.

For devices utilizing multiple antennas, KDB 662911 provides guidance for determining the effective array transmit antenna gain term to be used in the above equation.

EUT includes different power levels for head use configuration and body use configuration and the below tables contain the highest of all configurations average conducted and ERP/EIRP output powers as follows:

5.1.4. Test Data

Table 7 Maximum Output Power Results

Test Band	Test Mode	Test Channel	Conducted (Average) (dBm)	Antenna Gain (dBi)	ERP		FCC Limit (dBm)	IC Limit (dBm)	Verdict
					dBm	mW			
1xRTT – BC10 SECONDARY 800	TM1	Ch. 450/ 817.25MHz	20.22	-5	15.22	33.3	50	44.8	PASS
	TM1	Ch. 560/ 820MHz	20.23	-5	15.23	33.3	50	44.8	PASS
	TM1	Ch. 670/ 822.75MHz	20.14	-5	15.14	32.7	50	44.8	PASS
1xEV-DO – BC10 SECONDARY 800	TM2	Ch. 450/ 817.25MHz	20.25	-5	15.25	33.3	50	44.8	PASS
	TM2	Ch. 560/ 820MHz	20.16	-5	15.16	32.8	50	44.8	PASS
	TM2	Ch. 670/ 822.75MHz	20.14	-5	15.14	32.7	50	44.8	PASS

Table 8 Maximum Output Power Results

Test Band	Test Mode	Test Channel	Conducted (Average) (dBm)	Antenna Gain (dBi)	ERP		FCC Limit (dBm)	IC Limit (dBm)	Verdict
					dBm	mW			
1xRTT – BC0 CELL Band	TM1	Ch. 1013/ 824.7MHz	22.37	-5	17.37	54.6	38.5	40.6	PASS
	TM1	Ch. 384/ 836.52MHz	22.56	-5	17.56	57.0	38.5	40.6	PASS
	TM1	Ch. 777/ 848.31 MHz	22.42	-5	17.42	55.2	38.5	40.6	PASS
1xEV-DO –BC0 CELL Band	TM2	Ch. 1013/ 824.7MHz	22.28	-5	17.28	53.5	38.5	40.6	PASS
	TM2	Ch. 384/ 836.52MHz	22.39	-5	17.39	54.8	38.5	40.6	PASS
	TM2	Ch. 777/ 848.31 MHz	22.42	-5	17.42	55.2	38.5	40.6	PASS



Table 9 Maximum Output Power Results

Test Band	Test Mode	Test Channel	Conducted (Average) (dBm)	Antenna Gain (dBi)	ERP		FCC Limit (dBm)	IC Limit (dBm)	Verdict
					dBm	mW			
1xRTT – BC1 PCS Band	TM1	Ch. 25/ 1851.25MHz	24.96	-5	19.96	99.1	33	33	PASS
	TM1	h. 600/ 1880MHz	24.74	-5	19.74	94.2	33	33	PASS
	TM1	Ch. 1175/ 1908.75 MHz	24.72	-5	19.72	93.8	33	33	PASS
1xEV-DO REV0-BC1 PCS Band	TM2	Ch. 25/ 1851.25MHz	24.52	-5	19.52	89.5	33	33	PASS
	TM2	h. 600/ 1880MHz	24.23	-5	19.23	83.8	33	33	PASS
	TM2	Ch. 1175/ 1908.75 MHz	24.51	-5	19.51	89.3	33	33	PASS



5.2. Peak to Average Ratio

5.2.1. Test Standard

FCC: CFR 47 (FCC) part 2.1046, CFR 47 (FCC) 24.232(d)

IC : RSS-132§5.4, RSS-133§6.8

5.2.2. Test Limit

The peak-to-average ratio (PAR) of the transmission may not exceed 13 dB.

5.2.3. Test Procedure

A peak to average ratio measurement is performed at the conducted port of the EUT. For CDMA2000 signals, the spectrum analyzers Complementary Cumulative Distribution Function (CCDF) measurement profile is used to determine the largest deviation between the average and the peak power of the EUT in a given bandwidth. The CCDF curve shows how much time the peak waveform spends at or above a given average power level. The percent of time the signal spends at or above the level defines the probability for that particular power level.

5.2.4. Test Data

Table 10 Peak-to-average Ratio Results

Test Band	Test Mode	Test Channel	Measured[dB]	Limit [dB]	Verdict
1xRTT – BC10 SECONDARY 800	TM1	Ch. 450/ 817.25MHz	1.78	13	PASS
	TM1	Ch. 560/ 820MHz	3.32	13	PASS
	TM1	Ch. 670/ 822.75MHz	3.90	13	PASS
1xEV-DO – BC10 SECONDARY 800	TM2	Ch. 450/ 817.25MHz	1.97	13	PASS
	TM2	Ch. 560/ 820MHz	3.68	13	PASS
	TM2	Ch. 670/ 822.75MHz	4.54	13	PASS



Table 11 Peak-to-average Ratio Results

Test Band	Test Mode	Test Channel	Measured[dB]	Limit [dB]	Verdict
1xRTT – BC0 CELL Band	TM1	Ch. 1013/ 824.7MHz	4.09	13	PASS
	TM1	Ch. 384/ 836.52MHz	3.99	13	PASS
	TM1	Ch. 777/ 848.31 MHz	3.83	13	PASS
1xEV-DO –BC0 CELL Band	TM2	Ch. 1013/ 824.7MHz	4.42	13	PASS
	TM2	Ch. 384/ 836.52MHz	4.27	13	PASS
	TM2	Ch. 777/ 848.31 MHz	4.38	13	PASS

Table 12 Peak-to-average Ratio Results

Test Band	Test Mode	Test Channel	Measured[dB]	Limit [dB]	Verdict
1xRTT – BC1 PCS Band	TM1	Ch. 25/ 1851.25MHz	4.52	13	PASS
	TM1	Ch. 600/ 1880MHz	3.93	13	PASS
	TM1	Ch. 1175/ 1908.75 MHz	3.85	13	PASS
1xEV-DO REV0–BC1 PCS Band	TM2	Ch. 25/ 1851.25MHz	4.18	13	PASS
	TM2	Ch. 600/ 1880MHz	3.85	13	PASS
	TM2	Ch. 1175/ 1908.75 MHz	3.77	13	PASS

Test Band = 1xRTT – BC10 SECONDARY 800
Test Mode = TM1
Test Channel = LCH

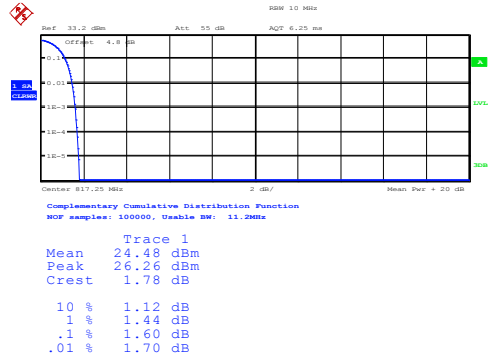

Date: 6.SEP.2018 16:53:27

Test Band = 1xRTT – BC10 SECONDARY 800
Test Mode = TM1
Test Channel = MCH

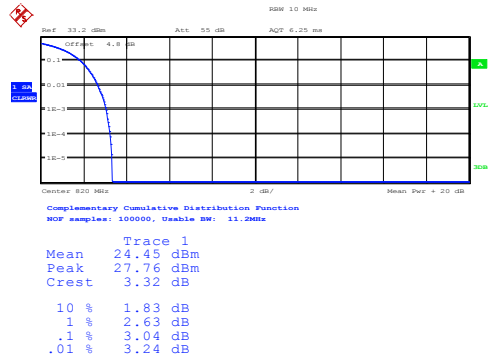

Date: 6.SEP.2018 16:53:46

Test Band = 1xRTT – BC10 SECONDARY 800
Test Mode = TM1
Test Channel = HCH

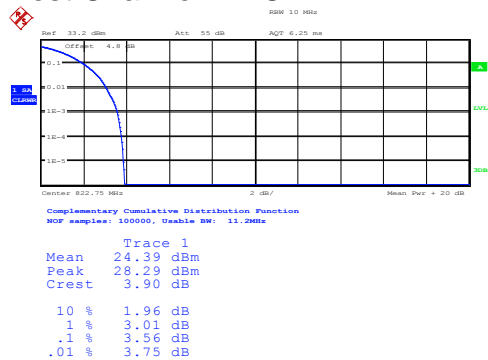

Date: 6.SEP.2018 16:54:34

Test Band = 1xEV-DO – BC10 SECONDARY 800
Test Mode = TM2
Test Channel = LCH

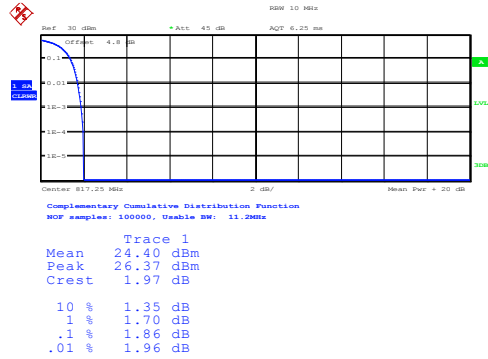

Date: 7.SEP.2018 10:47:16

Test Band = 1xEV-DO – BC10 SECONDARY 800
Test Mode = TM2
Test Channel = MCH

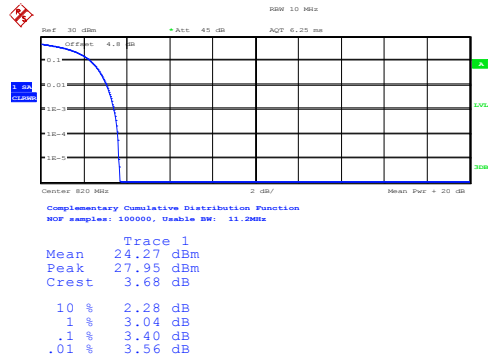

Date: 7.SEP.2018 10:47:45

Test Band = 1xEV-DO – BC10 SECONDARY 800
Test Mode = TM2
Test Channel = HCH

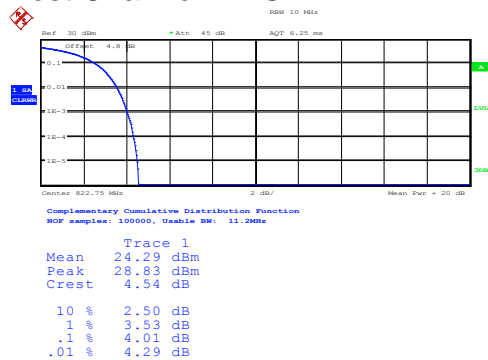

Date: 7.SEP.2018 10:48:19

Test Band = 1xRTT – BC0 CELL Band
Test Mode = TM1
Test Channel = LCH

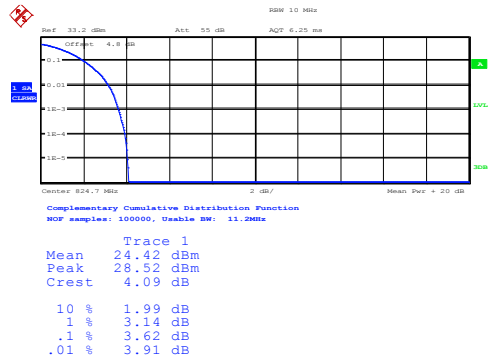

Date: 6.SEP.2018 16:50:38

Test Band = 1xRTT – BC0 CELL Band
Test Mode = TM1
Test Channel = MCH

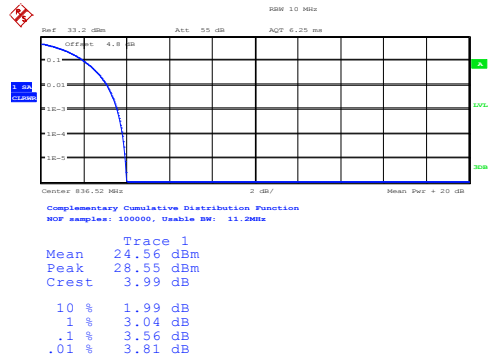

Date: 6.SEP.2018 16:50:57

Test Band = 1xRTT – BC0 CELL Band
Test Mode = TM1
Test Channel = HCH

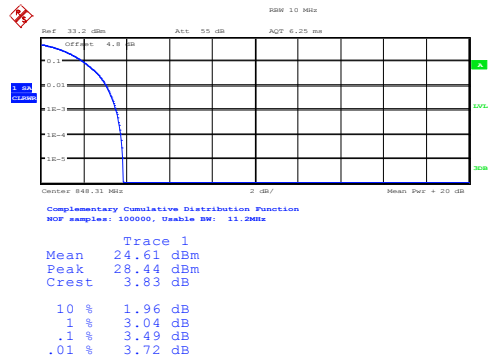

Date: 6.SEP.2018 16:55:01

Test Band = 1xEV-DO – BC0 CELL Band
Test Mode = TM2
Test Channel = LCH

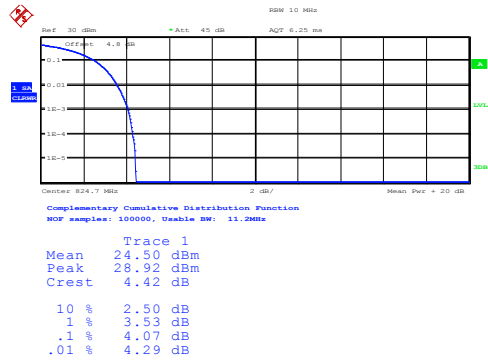

Date: 7.SEP.2018 10:46:14

Test Band = 1xEV-DO – BC0 CELL Band
Test Mode = TM2
Test Channel = MCH

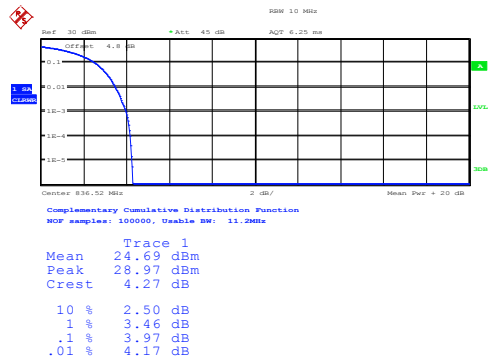

Date: 7.SEP.2018 10:46:28

Test Band = 1xEV-DO – BC0 CELL Band
Test Mode = TM2
Test Channel = HCH

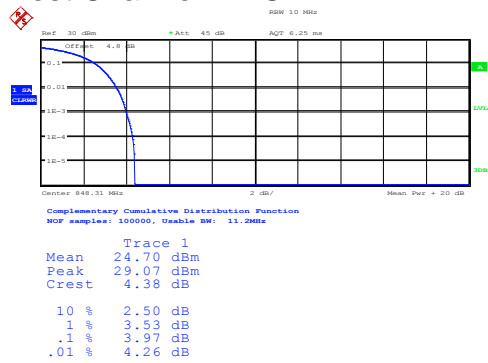

Date: 7.SEP.2018 10:46:43

Test Band = 1xRTT – BC1 PCS Band
Test Mode = TM1
Test Channel = LCH

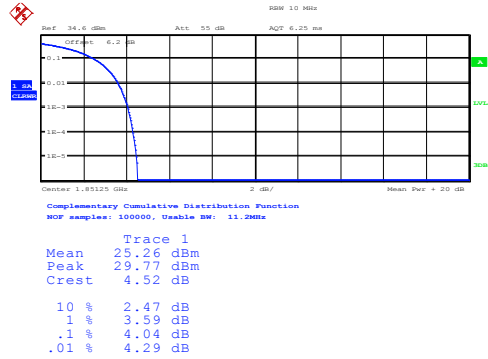

Date: 6.SEP.2018 16:49:34

Test Band = 1xRTT – BC1 PCS Band
Test Mode = TM1
Test Channel = MCH

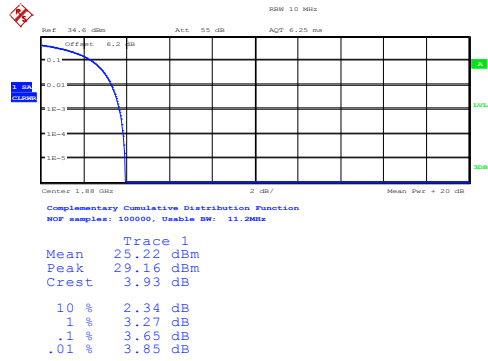

Date: 6.SEP.2018 16:49:10

Test Band = 1xRTT – BC1 PCS Band
Test Mode = TM1
Test Channel = HCH

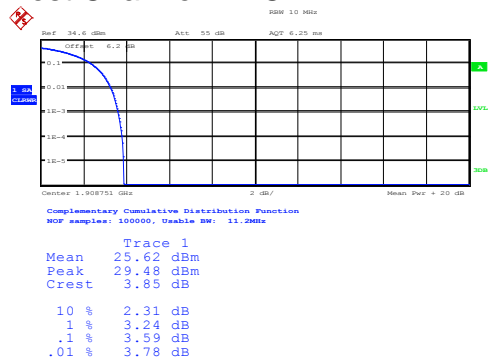

Date: 6.SEP.2018 16:48:43

Test Band = 1xEV-DO – BC1 PCS Band
Test Mode = TM2
Test Channel = LCH

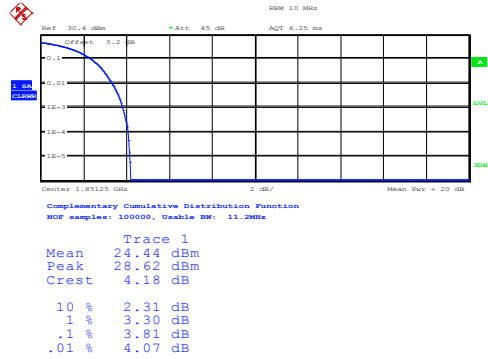

Date: 7.SEP.2018 10:45:37

Test Band = 1xEV-DO – BC1 PCS Band
Test Mode = TM2
Test Channel = MCH

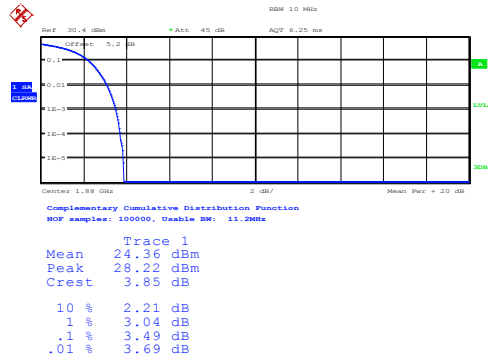

Date: 7.SEP.2018 10:45:18

Test Band = 1xEV-DO – BC1 PCS Band
Test Mode = TM2
Test Channel = HCH

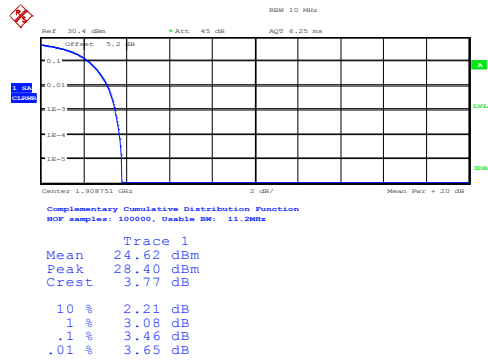

Date: 7.SEP.2018 10:45:04



5.3. Occupied Bandwidth/Emission Bandwidth

5.3.1. Test Standard

FCC: CFR Part 2.1049, CFR Part 22.917, CFR Part 24.238, CFR Part 90.209
IC : RSS-132, RSS-133§2.3, RSS-119§5.5

5.3.2. Test Limit

The occupied bandwidth, that is the frequency bandwidth such that, below its lower and above its upper frequency limits, the mean powers radiated are each equal to 0.5 percent of the total mean power radiated by a given emission shall be measured under the following conditions as applicable.

(h) Transmitters employing digital modulation techniques-when modulated by an input signal such that its amplitude and symbol rate represent the maximum rated conditions under which the equipment will be operated.

5.3.3. Test Procedure

1. Connect the equipment as shown in the above diagram.
 2. Adjust the settings of the Universal Radio Communication Tester (CMU) to set the EUT to its maximum power at the required channel.
 3. Set the spectrum analyzer to measure the 99% occupied bandwidth. Record the value.
 4. Set the spectrum analyzer to measure the -26 dB emission bandwidth. Record the value.
 5. Measurements are to be performed with the EUT set to the low, middle and high channel of each frequency band.
- Spectrum analyzer settings: Measurement bandwidth of at least 1% of the occupied bandwidth.



5.3.4. Test Data

Table 13 Occupied Bandwidth Test Data

1xRTT – BC10 SECONDARY 800:TM1		
CHANNEL FREQUENCY (MHz)	99% OBW (MHz)	26dBc BANDWIDTH (MHz)
817.25	1.2823	1.4625
820	1.2735	1.4395
822.75	1.2720	1.4274

Test Band = 1xRTT – BC10 SECONDARY 800

Test Mode = TM1

Test Channel = LCH

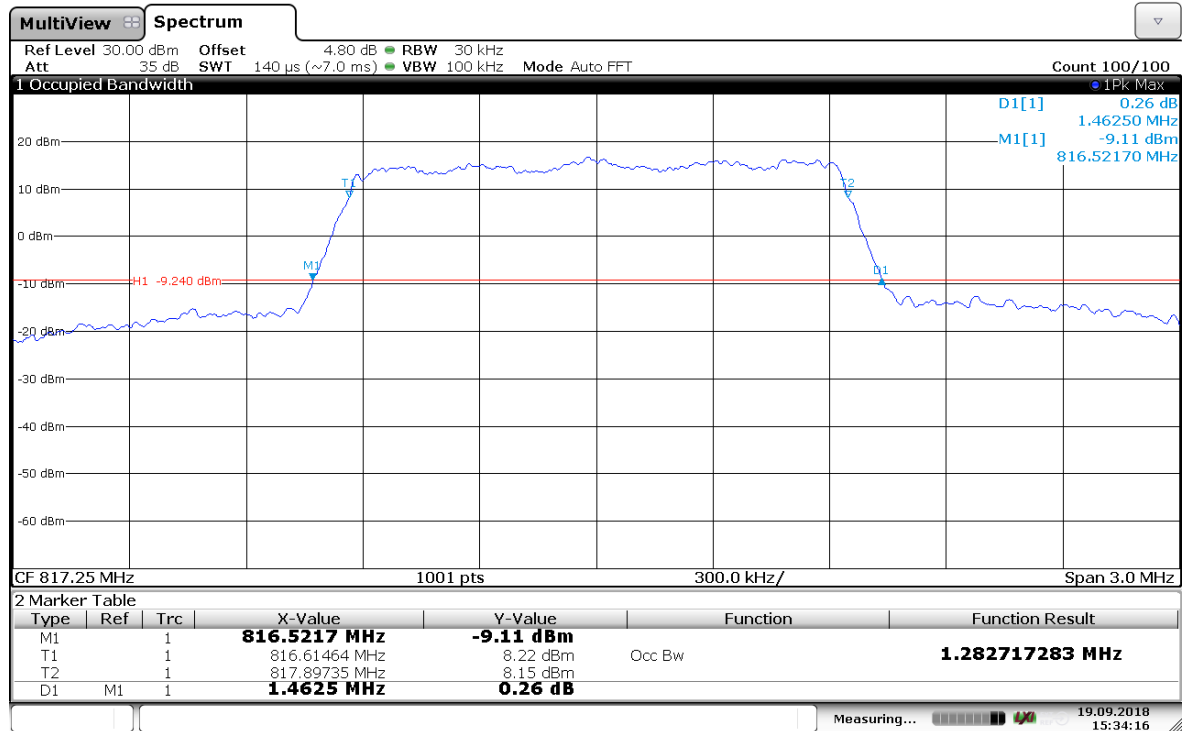

Test Band = 1xRTT – BC10 SECONDARY 800
 Test Mode = TM1
 Test Channel = MCH

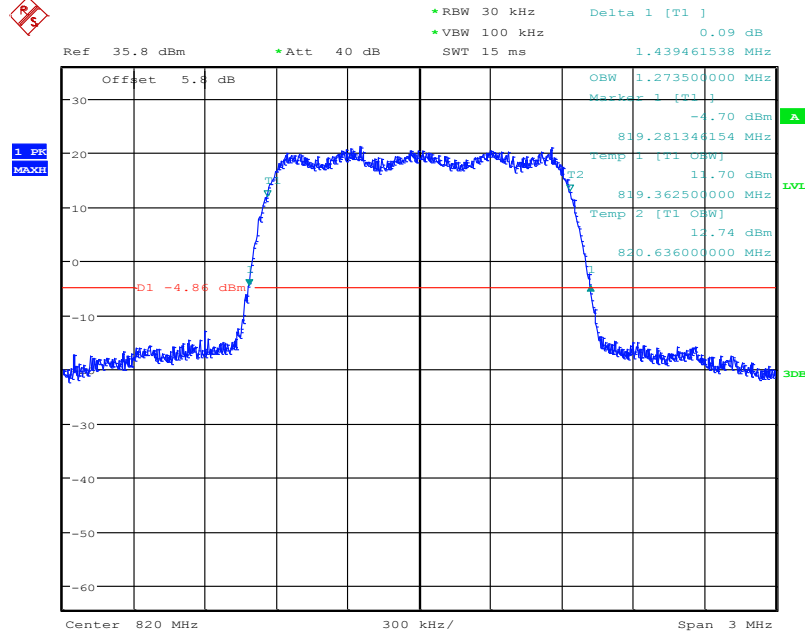

Date: 6.SEP.2018 11:00:43

Test Band = 1xRTT – BC10 SECONDARY 800
 Test Mode = TM1
 Test Channel = HCH

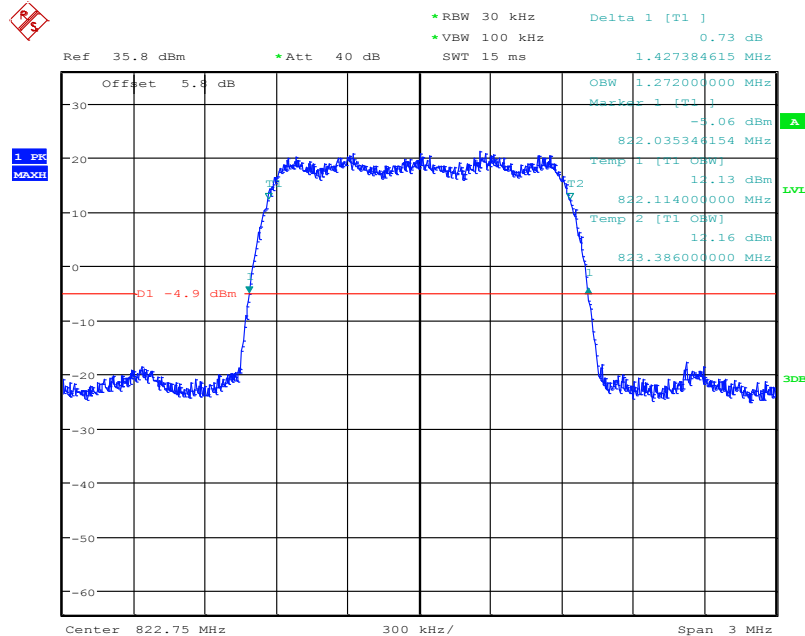

Date: 6.SEP.2018 11:53:01



Table 14 Occupied Bandwidth Test Data

1xEV-DO – BC10 SECONDARY 800:TM2		
CHANNEL FREQUENCY (MHz)	99% OBW (MHz)	26dBc BANDWIDTH (MHz)
817.25	1.2737	1.4446
820	1.2750	1.4372
822.75	1.2750	1.4263

Test Band = 1xEV-DO – BC10 SECONDARY 800
Test Mode = TM2
Test Channel = LCH



Test Band = 1xEV-DO – BC10 SECONDARY 800
 Test Mode = TM2
 Test Channel = MCH

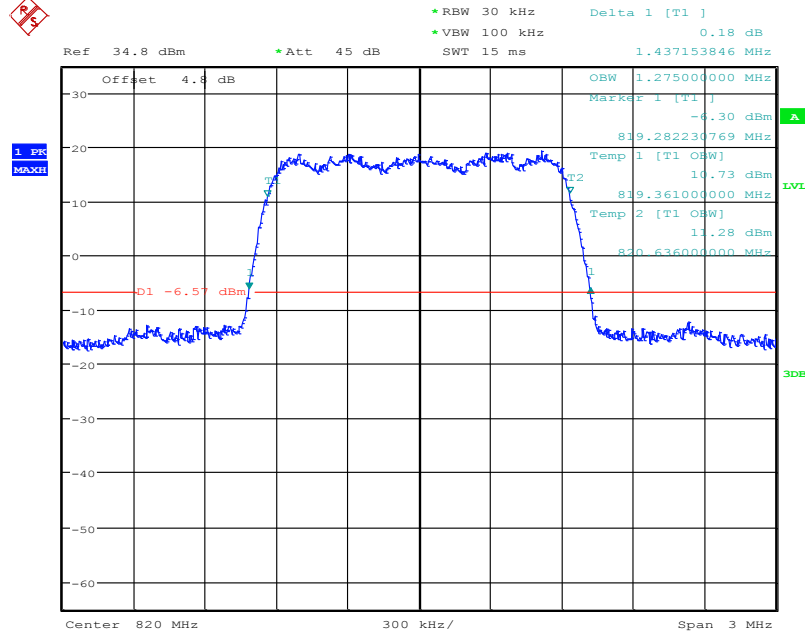

Date: 7.SEP.2018 10:08:18

Test Band = 1xEV-DO – BC10 SECONDARY 800
 Test Mode = TM2
 Test Channel = HCH

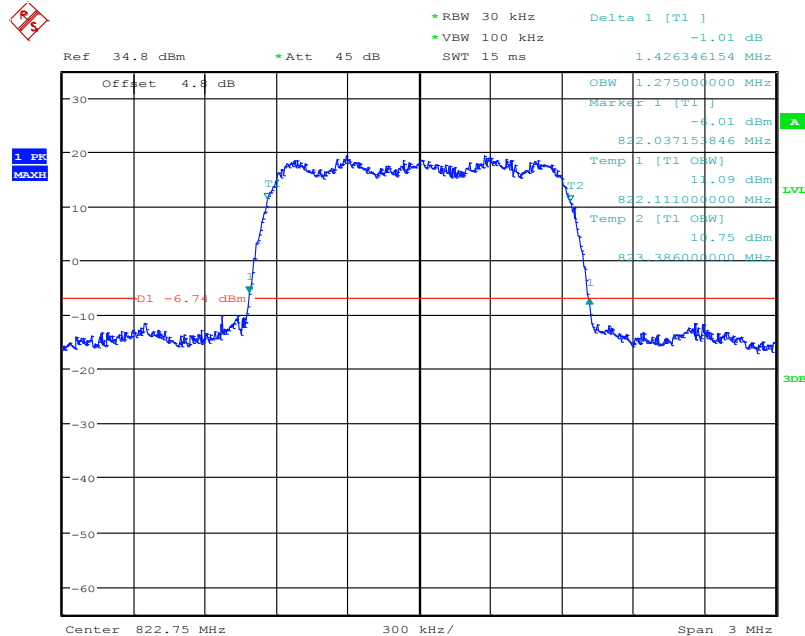

Date: 7.SEP.2018 10:10:24

Table 15 Occupied Bandwidth Test Data

1xRTT –BC0 CELL Band:TM1		
CHANNEL FREQUENCY (MHz)	99% OBW (MHz)	26dBc BANDWIDTH (MHz)
824.7	1.2720	1.4163
836.52	1.2720	1.4336
848.31	1.2750	1.4231

Test Band = 1xRTT –BC0 CELL Band
Test Mode = TM1
Test Channel = LCH

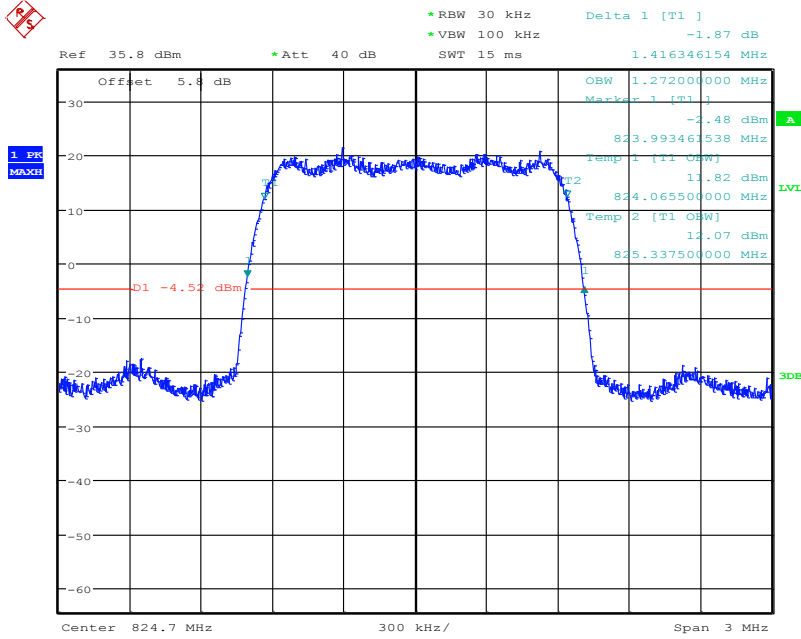

Date: 6.SEP.2018 10:39:57

Test Band = 1xRTT -BC0 CELL Band
 Test Mode = TM1
 Test Channel = MCH

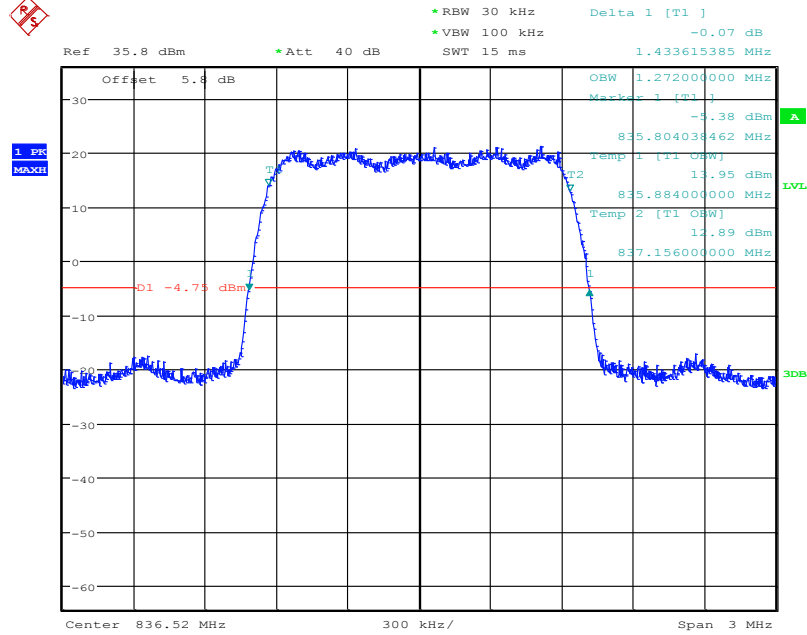

Date: 6.SEP.2018 10:44:30

Test Band = 1xRTT -BC0 CELL Band
 Test Mode = TM1
 Test Channel = HCH

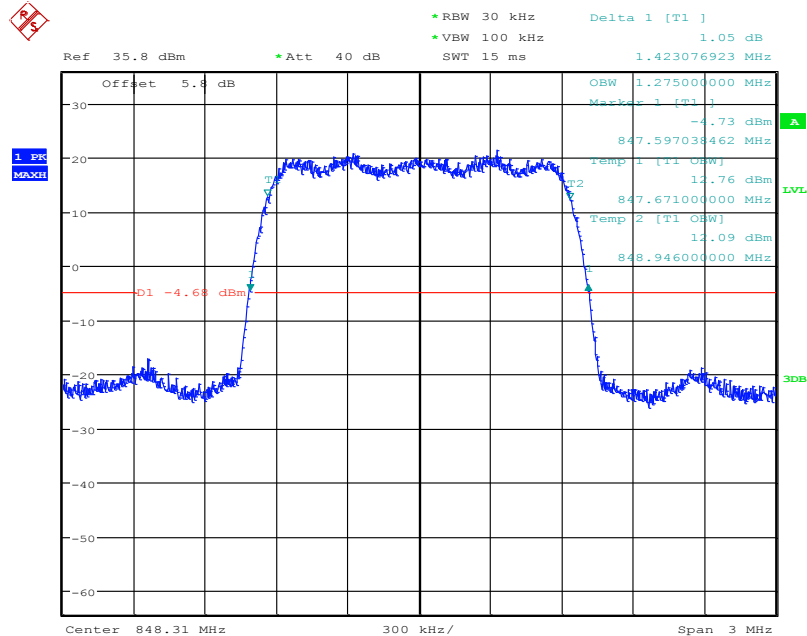

Date: 6.SEP.2018 10:46:28

Table 16 Occupied Bandwidth Test Data

1xEV-DO –BC0 CELL Band:TM2		
CHANNEL FREQUENCY (MHz)	99% OBW (MHz)	26dBc BANDWIDTH (MHz)
824.7	1.2750	1.4224
836.52	1.2750	1.4330
848.31	1.2750	1.4240

Test Band = 1xEV-DO –BC0 CELL Band
Test Mode = TM2
Test Channel = LCH

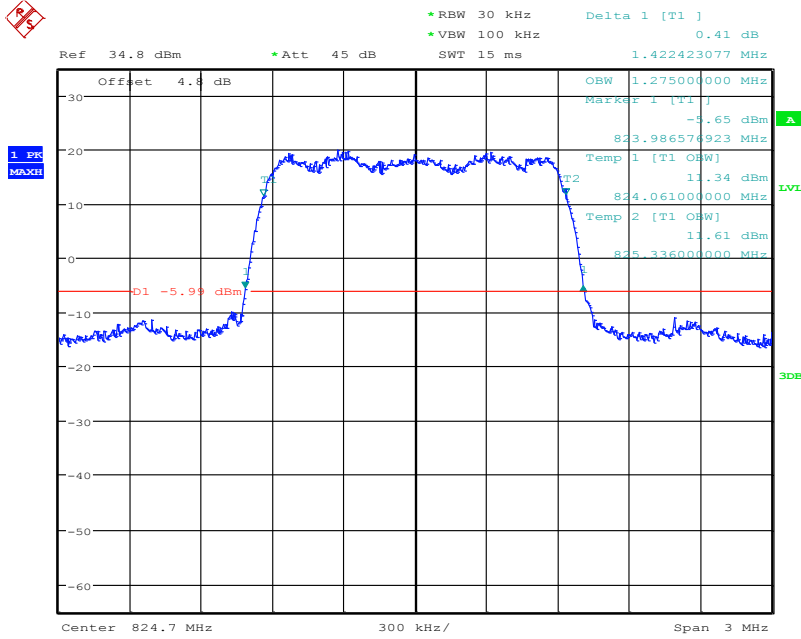

Date: 7.SEP.2018 10:01:19

Test Band = 1xEV-DO –BC0 CELL Band

Test Mode = TM2

Test Channel = MCH

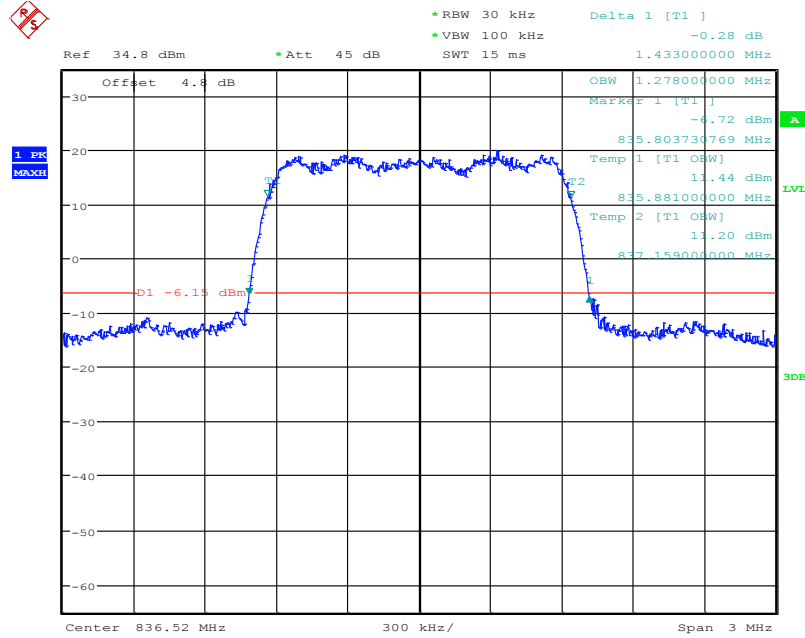

Date: 7.SEP.2018 10:02:31

Test Band = 1xEV-DO –BC0 CELL Band

Test Mode = TM2

Test Channel = HCH

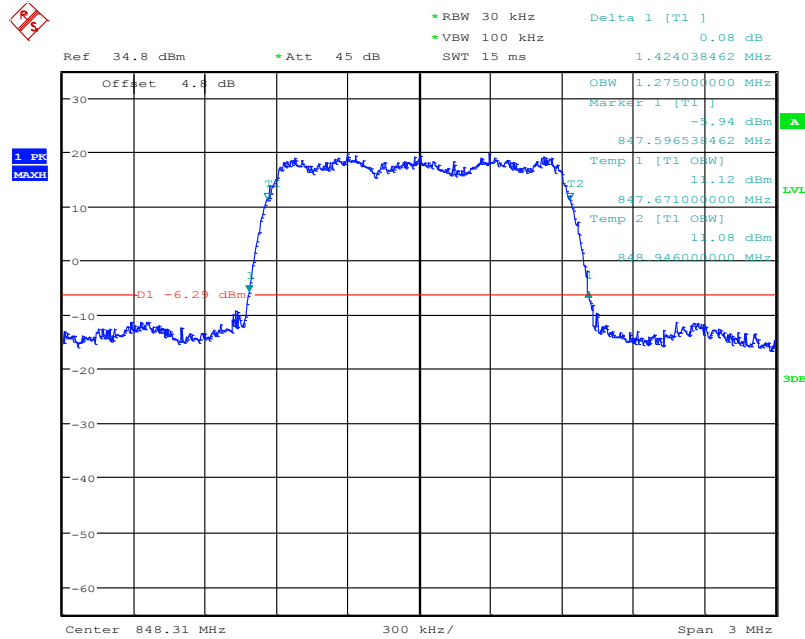

Date: 7.SEP.2018 10:03:50

Table 17 Occupied Bandwidth Test Data

1xRTT – BC1 PCS Band		
CHANNEL FREQUENCY (MHz)	99% OBW (MHz)	26dBc BANDWIDTH (MHz)
824.7	1.2780	1.4327
836.52	1.2810	1.4490
848.31	1.2750	1.4231

Test Band = 1xRTT – BC1 PCS Band
Test Mode = TM1
Test Channel = LCH

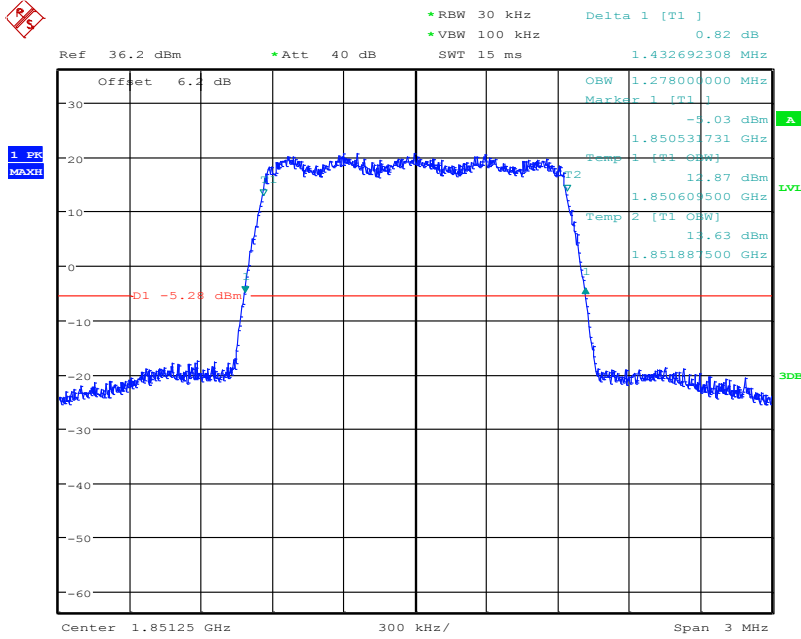

Date: 6.SEP.2018 10:18:37



Test Band = 1xRTT – BC1 PCS Band
Test Mode = TM1
Test Channel = MCH

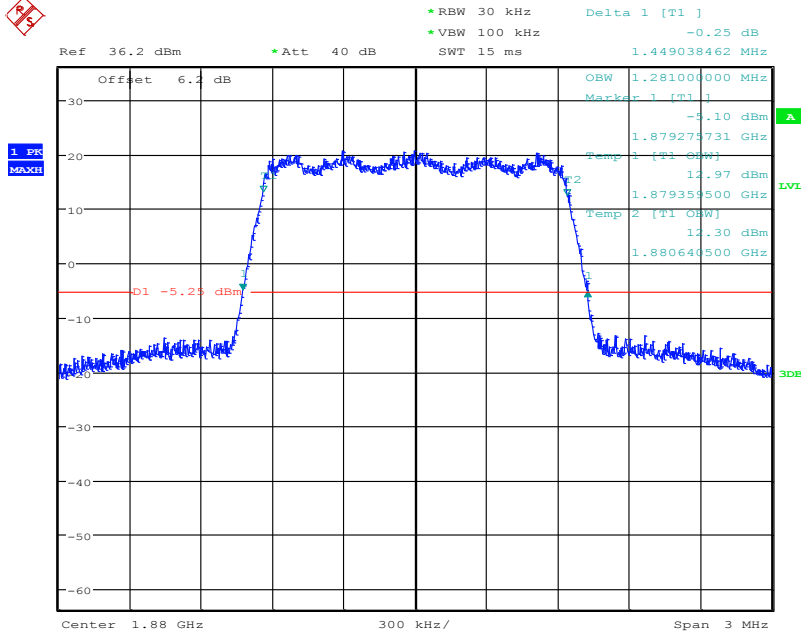

Date: 6.SEP.2018 10:20:19

Test Band = 1xRTT – BC1 PCS Band
Test Mode = TM1
Test Channel = HCH

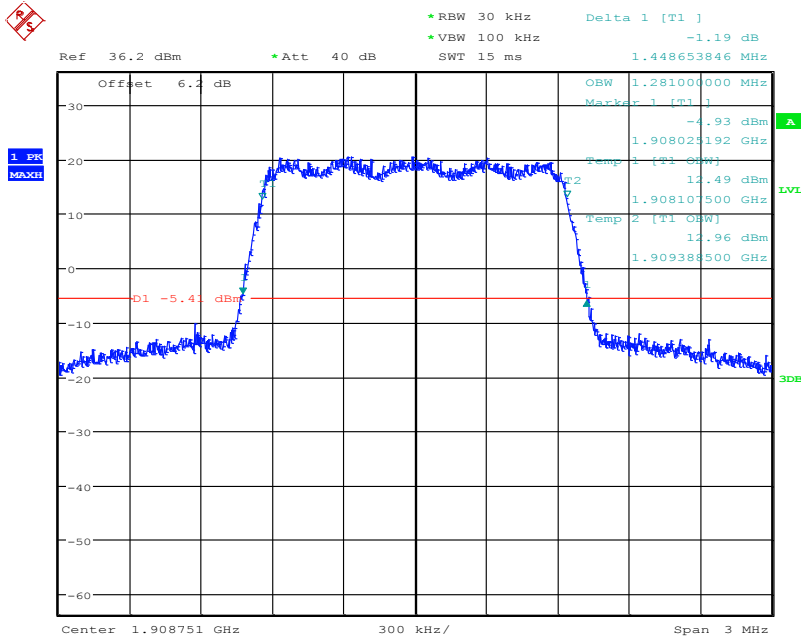

Date: 6.SEP.2018 10:36:46

Table 18 Occupied Bandwidth Test Data

1xEV-DO –BC1 PCS Band:TM2		
CHANNEL FREQUENCY (MHz)	99% OBW (MHz)	26dBc BANDWIDTH (MHz)
824.7	1.2720	1.4247
836.52	1.2750	1.4369
848.31	1.2750	1.4375

Test Band = 1xEV-DO –BC1 PCS Band
Test Mode = TM2
Test Channel = LCH

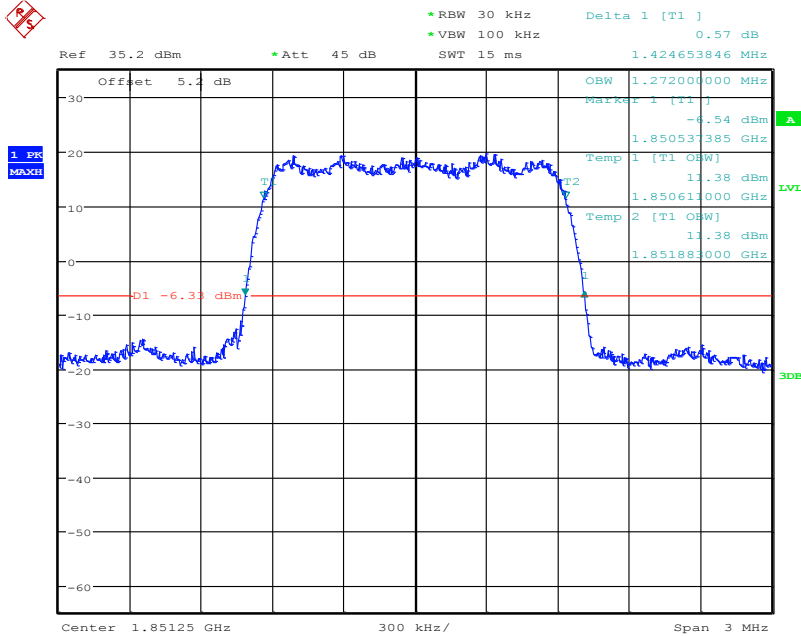

Date: 7.SEP.2018 10:12:06

Test Band = 1xEV-DO –BC1 PCS Band
 Test Mode = TM2
 Test Channel = MCH

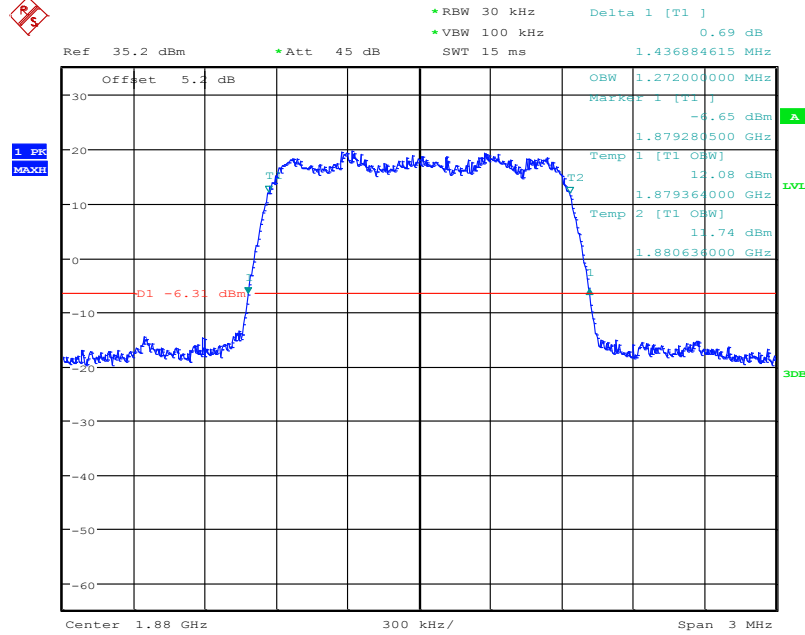

Date: 7.SEP.2018 10:12:56

Test Band = 1xEV-DO –BC1 PCS Band
 Test Mode = TM2
 Test Channel = HCH

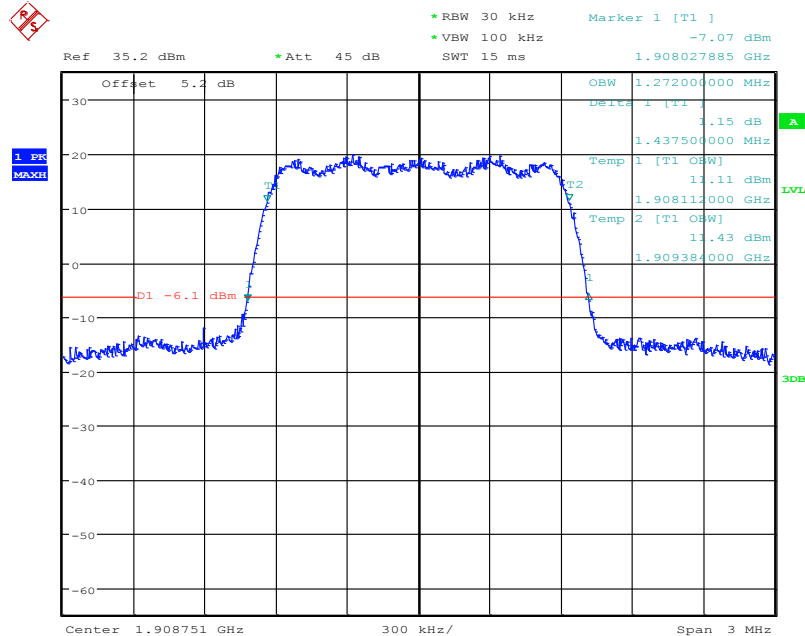

Date: 7.SEP.2018 10:14:20



5.4. Spurious Emission at Antenna Terminal

5.4.1. Test Standard

FCC: CFR Part 2.1051, CFR Part 22.917, CFR Part 24.238, CFR Part 90.669
IC: RSS-132§5.5, RSS-133§6.5, RSS-119§5.8

5.4.2. Test Limit

The radio frequency voltage or power generated within the equipment and appearing on a spurious frequency shall be checked at the equipment output terminals when properly loaded with a suitable artificial antenna. Curves or equivalent data shall show the magnitude of each harmonic and other spurious emission that can be detected when the equipment is operated under the conditions specified in FCC 2.1049 as appropriate. The magnitude of spurious emissions which are attenuated more than 20 dB below the permissible value need not be specified.

(a) Out of band emissions. The power of any emission outside of the authorized operating frequency ranges must be attenuated below the transmitting power (P) by a factor of at least $43 + 10 \log(P)$ dB. For all power levels +30dBm to 0dBm, this becomes a constant specification of -13dBm.

FCC 22.917 Emission limitations for cellular equipment.

The rules in this section govern the spectral characteristics of emissions in the Cellular Radiotelephone Service.

(b) Measurement procedure. Compliance with these provisions is based on the use of measurement instrumentation employing a resolution bandwidth of 100 kHz or greater. In the 1MHz bands immediately outside and adjacent to the frequency block a resolution bandwidth of at least one percent of the emission bandwidth of the fundamental emission of the transmitter may be employed. A narrower resolution bandwidth is permitted in all cases to improve measurement accuracy provided the measured power is integrated over the full required measurement bandwidth (i.e. 100 kHz of 1 percent of emission bandwidth, as specified). The emission bandwidth is defined as the width of the signal between two points, one below the carrier center frequency and one above the carrier center frequency, outside of which all emissions are attenuated at least 26 dB below the transmitter power.

FCC 24.238 Emission limitations for Broadband PCS equipment.

The rules in this section govern the spectral characteristics of emissions in the Broadband Personal Communications Service.

(b) Measurement procedure. Compliance with these provisions is based on the use of measurement instrumentation employing a resolution bandwidth of 1 MHz or greater. However, in the 1 MHz bands immediately outside and adjacent to the frequency block a resolution bandwidth of at least one percent of the emission bandwidth of the fundamental emission of the transmitter may be employed. A narrower resolution bandwidth is permitted in all cases to improve measurement accuracy provided the measured power is integrated over the full required measurement bandwidth (i.e. 100 kHz of 1 percent of emission bandwidth, as specified). The emission bandwidth is defined as the width of the signal between two points, one below the carrier center frequency and one above the carrier center frequency, outside of which all emissions are attenuated at least 26 dB below the transmitter power.

FCC 90.669 & RSS-119§5.5

(a) Out-of-band emission requirement shall apply only to the “outer” channels included in an EA license and to spectrum adjacent to interior channels used by incumbent licensees. The emission limits are as follows:

(1) For any frequency removed from the EA licensee's frequency block by up to and including 37.5 kHz, the power of any emission shall be attenuated below the transmitter power (P) in watts by at least $116 \text{ Log}_{10}(f/6.1)$ decibels or $50 + 10 \text{ Log}_{10}(P)$ decibels or 80 decibels, whichever is the lesser attenuation, where f is the frequency removed from the center of the outer channel in the block in kilohertz and where f is greater than 12.5 kHz.

(2) For any frequency removed from the EA licensee's frequency block greater than 37.5 kHz, the power of any emission shall be attenuated below the transmitter power (P) in watts by at least $43 + 10 \text{ Log}_{10}(P)$ decibels or 80 decibels, whichever is the lesser attenuation, where f is the frequency removed from the center of the outer channel in the block in kilohertz and where f is greater than 37.5 kHz.

The power of any emission shall be attenuated below the mean output power P (dBW) by at least $43 + 10 \log_{10}(p)$, measured in a 100 kHz bandwidth for frequencies less than or equal to 1 GHz, and in a 1 MHz bandwidth for frequencies greater than 1 GHz.

RSS-132§5.5: Mobile and base station equipment shall comply with the limits in (i) and (ii) below.

(i) In the first 1.0 MHz band immediately outside and adjacent to each of the sub-bands specified in Section 5.1, the power of emissions per any 1% of the occupied bandwidth shall be attenuated (in dB) below the transmitter output power P (dBW) by at least $43 + 10 \log_{10} p$ (watts).

(ii) After the first 1.0 MHz immediately outside and adjacent to each of the sub-bands, the power of emissions in any 100 kHz bandwidth shall be attenuated (in dB) below the transmitter output power P (dBW) by at least $43 + 10 \log_{10} p$ (watts). If the measurement is performed using 1% of the occupied bandwidth, power integration over 100 kHz is required.

RSS-133§6.5 Equipment shall comply with the limits in (i) and (ii) below.

(i) In the 1.0 MHz bands immediately outside and adjacent to the equipment's operating frequency block, the emission power per any 1% of the emission bandwidth shall be attenuated (in dB) below the transmitter output power P (dBW) by at least $43 + 10 \log_{10} p$ (watts).

(ii) After the first 1.0 MHz, the emission power in any 1 MHz bandwidth shall be attenuated (in dB) below the transmitter output power P (dBW) by at least $43 + 10 \log_{10} p$ (watts). If the measurement is performed using 1% of the emission bandwidth, power integration over 1.0 MHz is required.

5.4.3. Test Procedure

1. Connect the equipment as shown in the above diagram.
2. Set the spectrum analyzer to measure peak hold with the required settings.
3. Set the signal generator to a known output power and record the path loss in dB (LOSS) for frequencies up to the tenth harmonic of the EUT's carrier frequency.
 $\text{LOSS} = \text{Generator Output Power (dBm)} - \text{Analyzer reading (dBm)}$.
4. Replace the signal generator with the EUT.
5. Adjust the settings of the Universal Radio Communication Tester (CMU) to set

the EUT to its maximum power at the required channel.

6. Set the spectrum analyzer to measure peak hold with the required settings. Offset the spectrum analyzer reference level by the path loss measured above.

7. Measure and record all spurious emissions up to the tenth harmonic of the carrier frequency.

8. Measurements are to be performed with the EUT set to the low, middle and high channel of each frequency band.

9. If necessary steps 6 and 7 may be performed with the spectrum analyzer set to average detector.

(Note: Step 3 above is performed prior to testing and LOSS is recorded by test software. Steps 2, 6, and 7 above are performed with test software.)

5.4.4. Test Data

Out of band measurement

Test Band = 1xRTT – BC10 SECONDARY 800

Test Mode = TM1

Test Channel = LCH

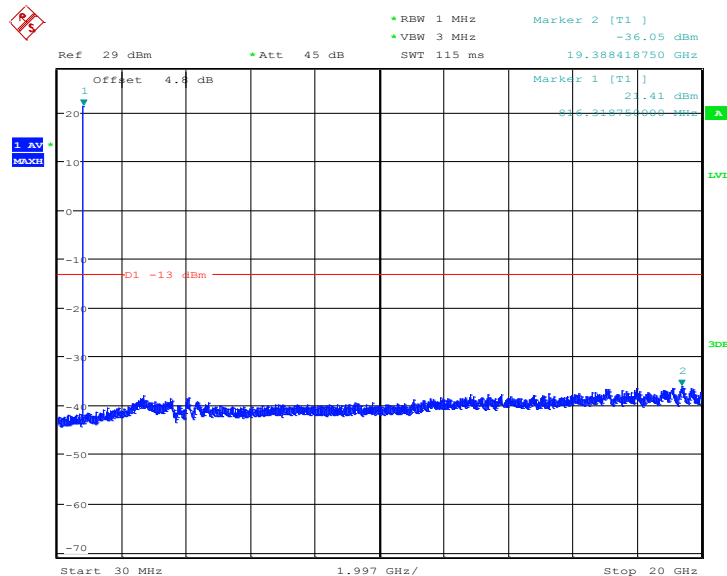

Date: 6.SEP.2018 16:31:17

Out of band measurement
 Test Band = 1xRTT – BC10 SECONDARY 800
 Test Mode = TM1
 Test Channel = MCH

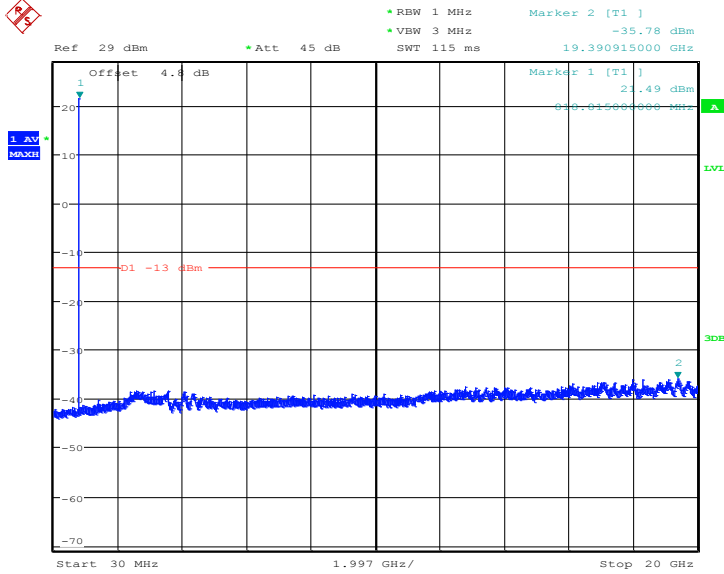

Date: 6.SEP.2018 16:32:51

Out of band measurement
 Test Band = 1xRTT – BC10 SECONDARY 800
 Test Mode = TM1
 Test Channel = HCH

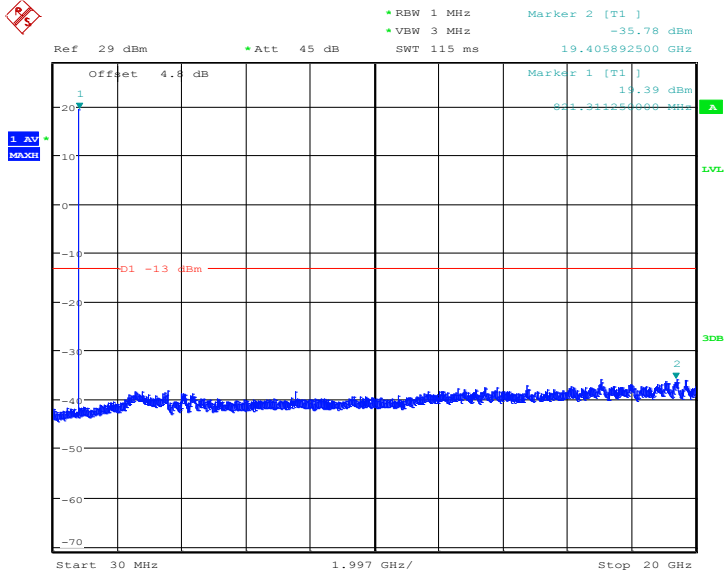

Date: 6.SEP.2018 16:33:25

Out of band measurement
 Test Band = 1xEV-DO – BC10 SECONDARY 800
 Test Mode = TM2
 Test Channel = LCH

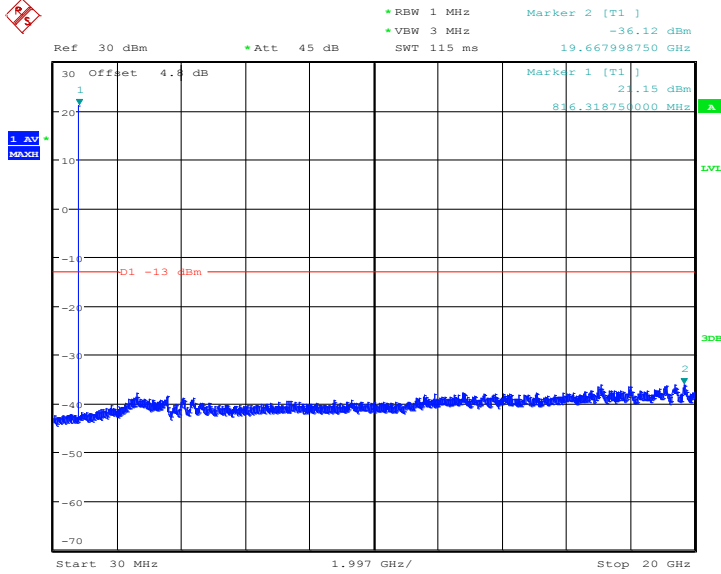

Date: 7.SEP.2018 10:40:09

Out of band measurement
 Test Band = 1xEV-DO – BC10 SECONDARY 800
 Test Mode = TM2
 Test Channel = MCH

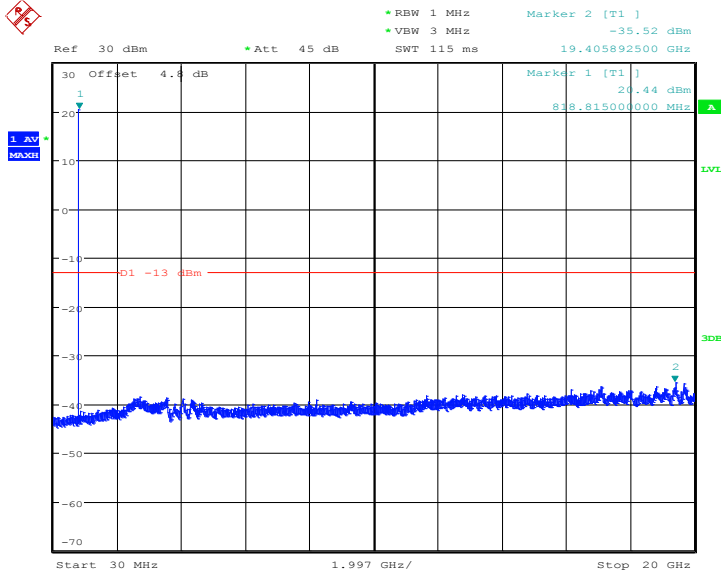

Date: 7.SEP.2018 10:37:36

Out of band measurement
 Test Band = 1xEV-DO – BC10 SECONDARY 800
 Test Mode = TM2
 Test Channel = HCH

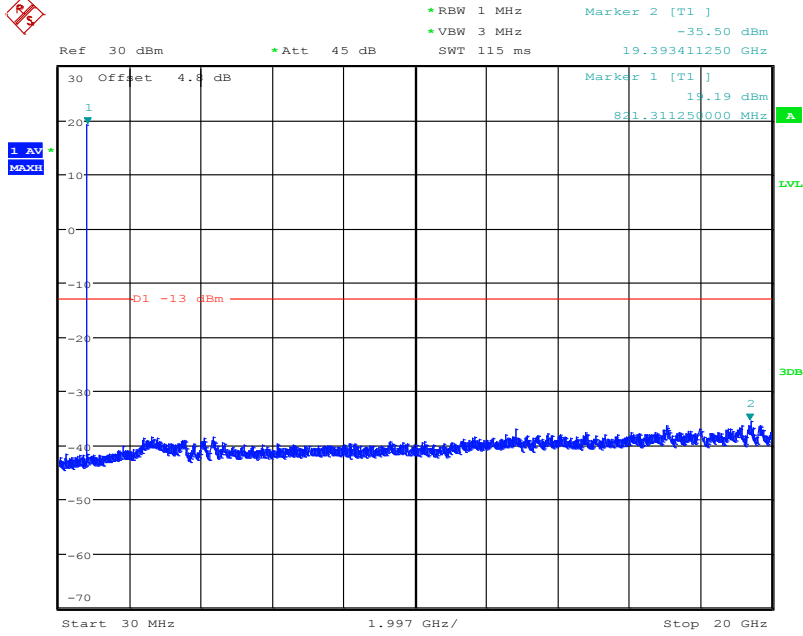

Date: 7.SEP.2018 10:37:13

Out of band measurement
 Test Band = 1xRTT –BC0 CELL Band
 Test Mode = TM1
 Test Channel = LCH

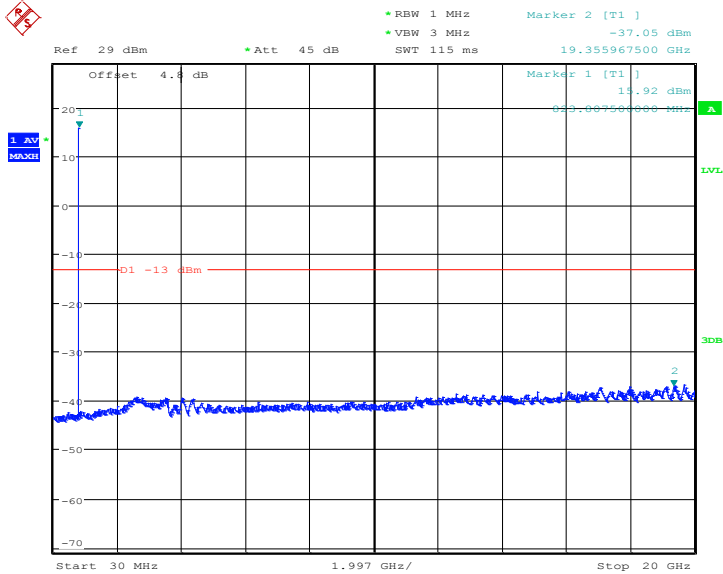

Date: 6.SEP.2018 16:23:37

Out of band measurement
Test Band = 1xRTT –BC0 CELL Band
Test Mode = TM1
Test Channel = MCH

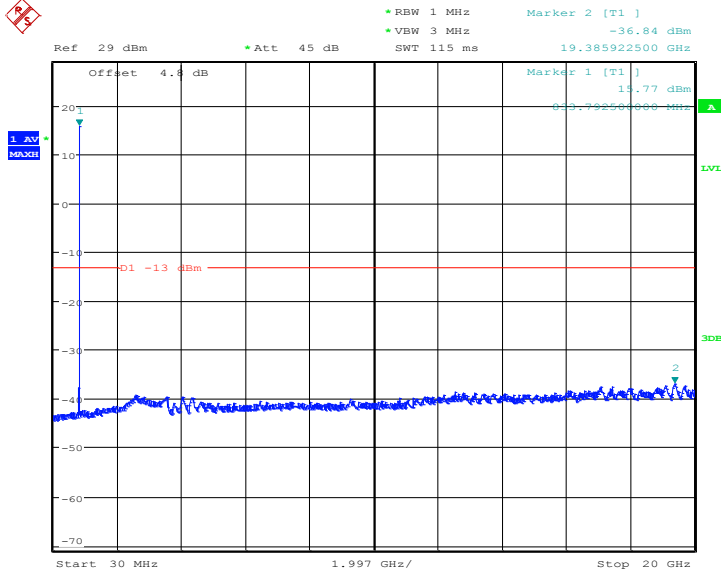

Date: 6.SEP.2018 16:24:12

Out of band measurement
Test Band = 1xRTT –BC0 CELL Band
Test Mode = TM1
Test Channel = HCH

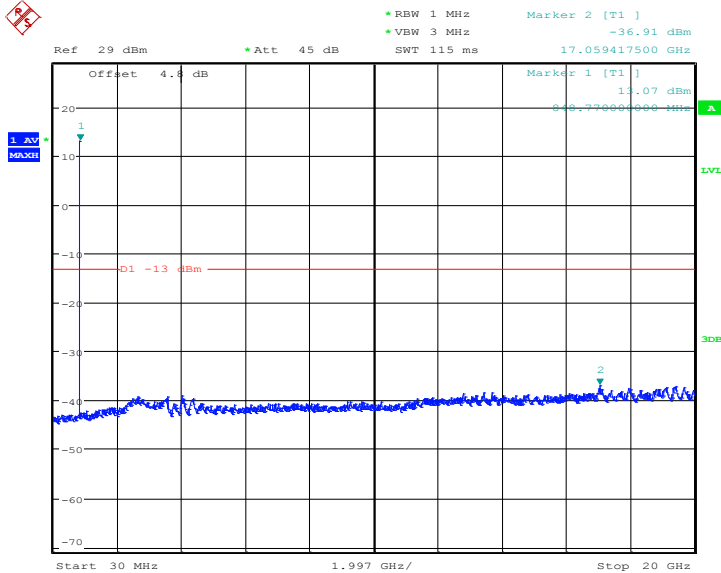

Date: 6.SEP.2018 16:24:37

Out of band measurement
Test Band = 1xEV-DO –BC0 CELL Band
Test Mode = TM2
Test Channel = LCH

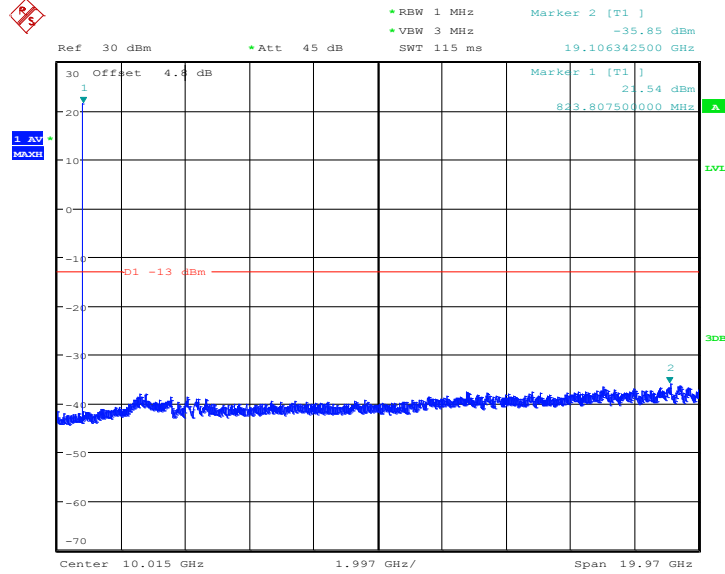

Date: 7.SEP.2018 10:41:14

Out of band measurement
Test Band = 1xEV-DO –BC0 CELL Band
Test Mode = TM2
Test Channel = MCH

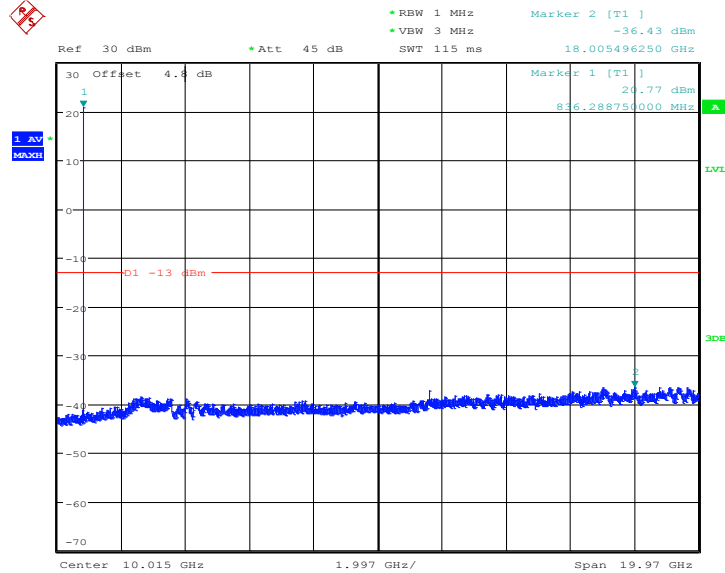

Date: 7.SEP.2018 10:42:10

Out of band measurement
Test Band = 1xEV-DO –BC0 CELL Band
Test Mode = TM2
Test Channel = HCH

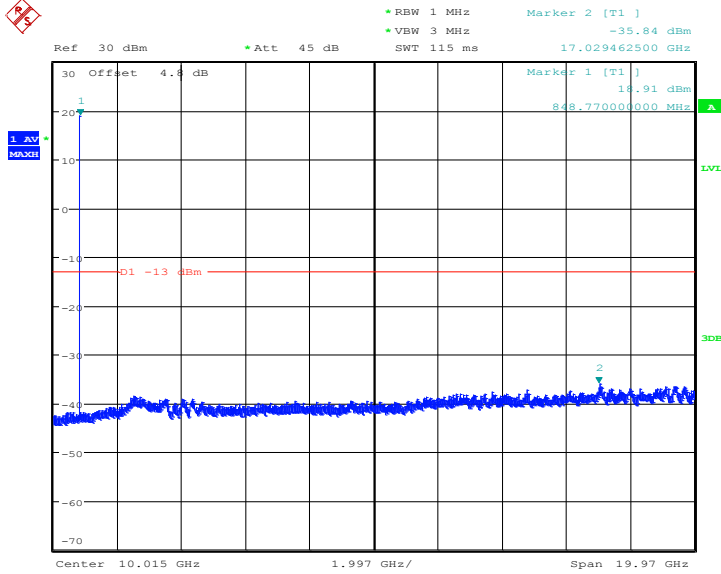

Date: 7.SEP.2018 10:42:42

Out of band measurement
Test Band = 1xRTT – BC1 PCS Band
Test Mode = TM1
Test Channel = LCH

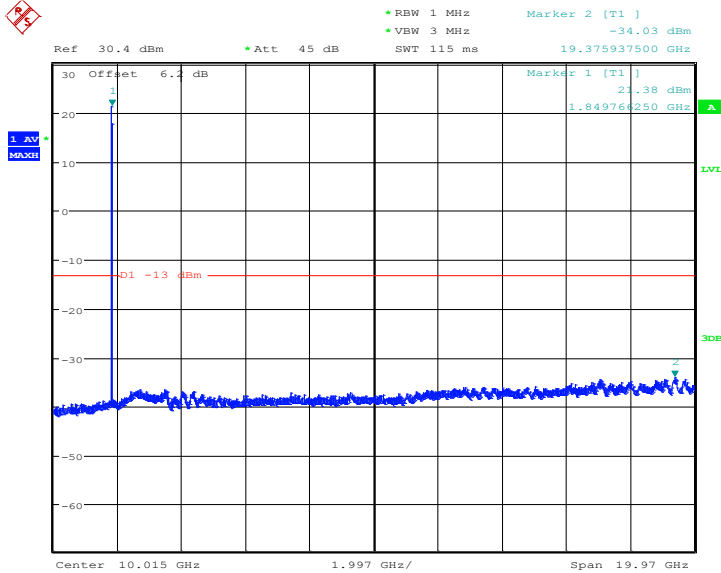

Date: 6.SEP.2018 16:38:00

Out of band measurement
Test Band = 1xRTT – BC1 PCS Band
Test Mode = TM1
Test Channel = MCH

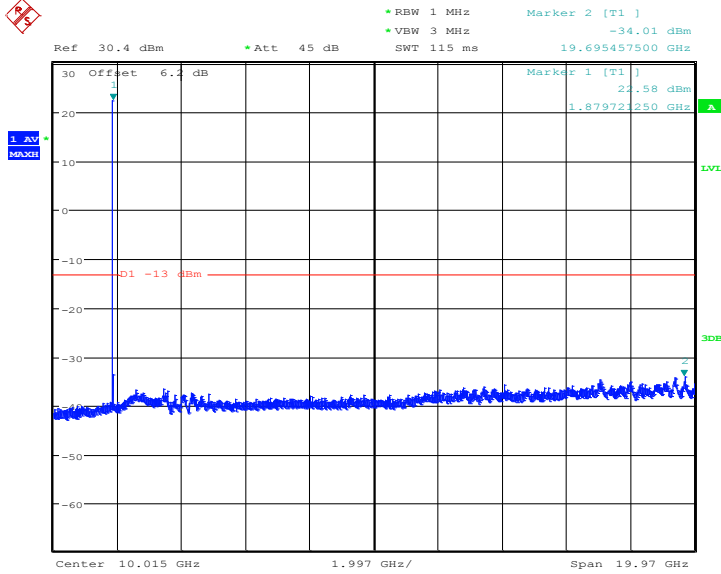

Date: 6.SEP.2018 16:38:28

Out of band measurement
Test Band = 1xRTT – BC1 PCS Band
Test Mode = TM1
Test Channel = HCH

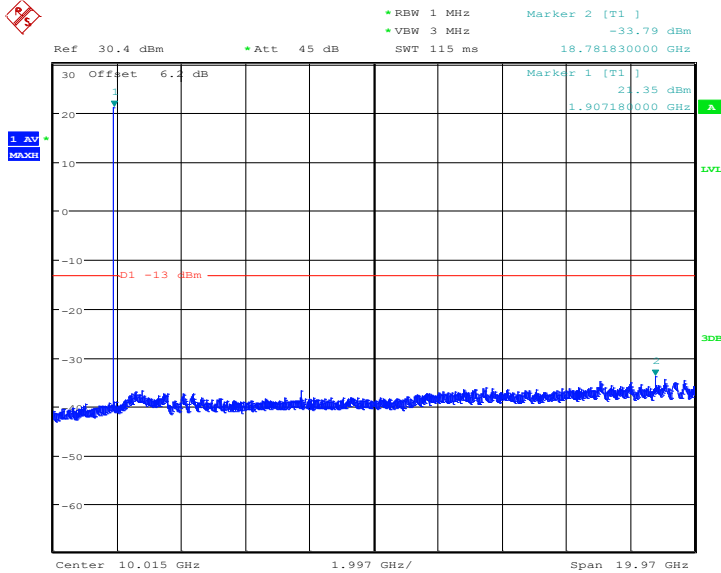

Date: 6.SEP.2018 16:38:54

Out of band measurement
Test Band = 1xEV-DO –BC1 PCS Band
Test Mode = TM2
Test Channel = LCH

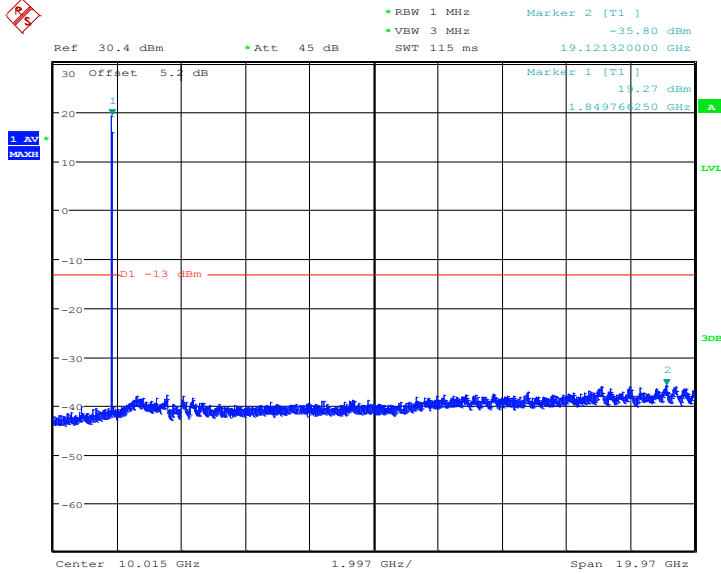

Date: 7.SEP.2018 10:43:27

Out of band measurement
Test Band = 1xEV-DO –BC1 PCS Band
Test Mode = TM2
Test Channel = MCH

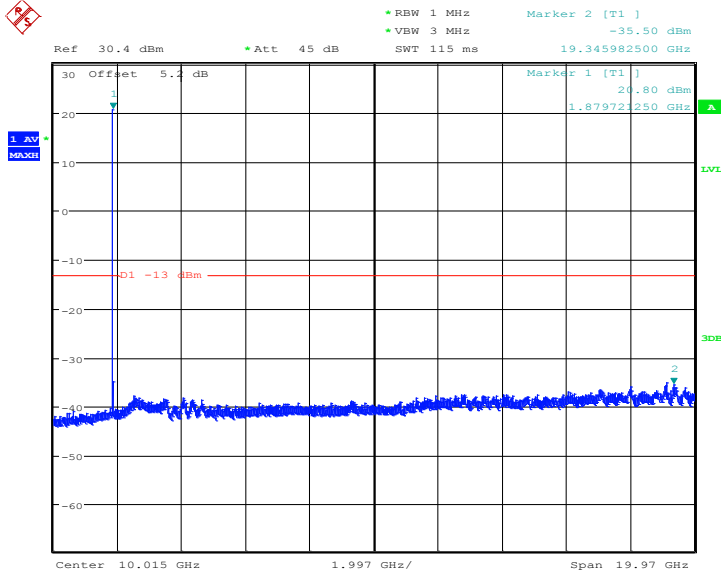

Date: 7.SEP.2018 10:43:48



Out of band measurement
Test Band = 1xEV-DO -BC1 PCS Band
Test Mode = TM2
Test Channel = HCH

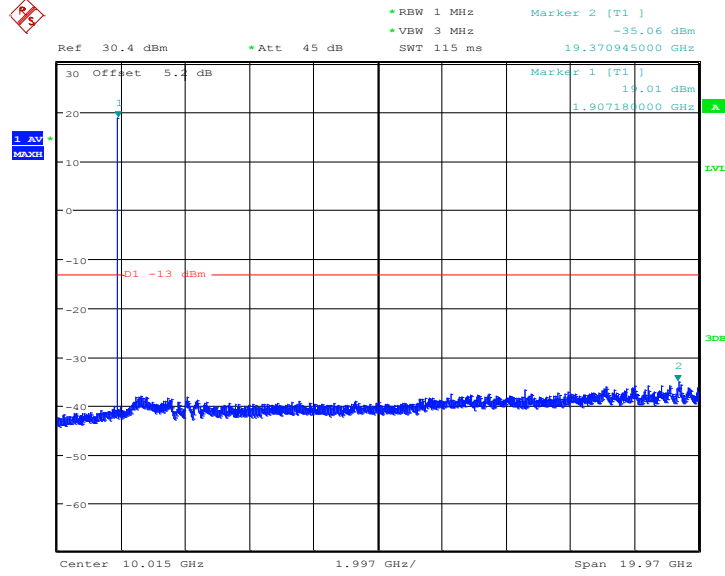

Date: 7.SEP.2018 10:44:15



Band edge measurement
Test Band = 1xRTT – BC10 SECONDARY 800
Test Mode = TM1
Test Channel = LCH/HCH

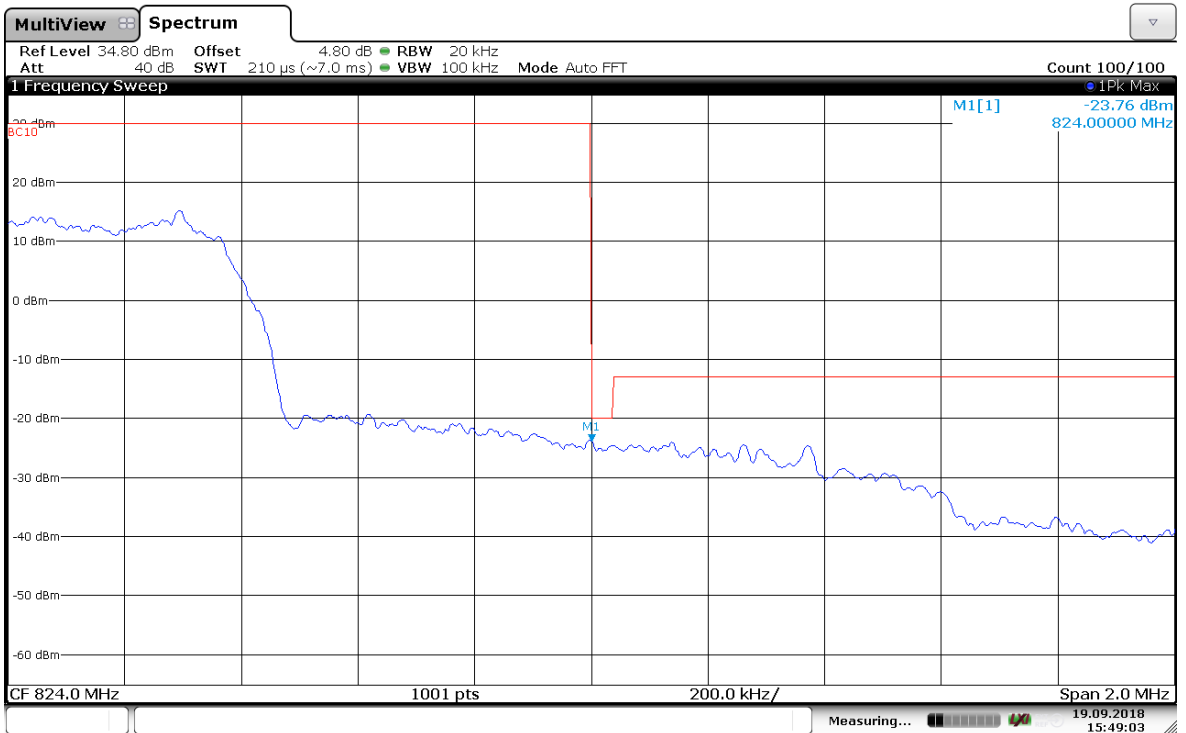
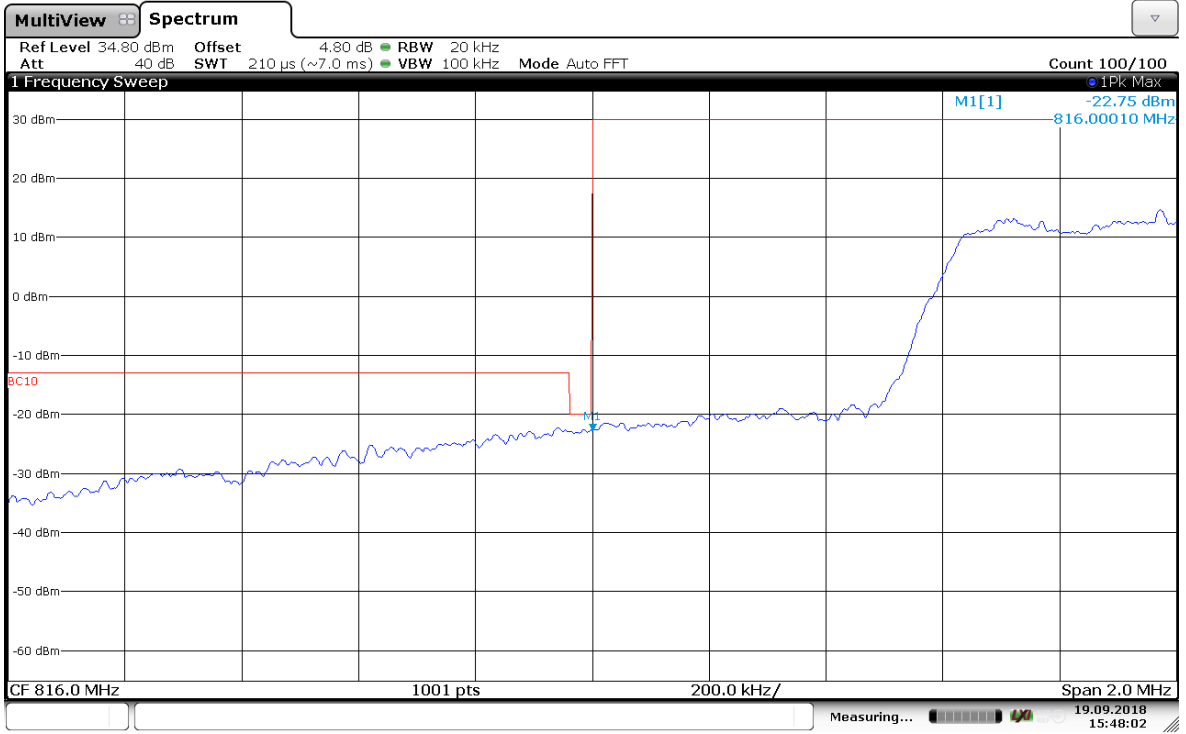



Band edge measurement
Test Band = 1xEV-DO – BC10 SECONDARY 800
Test Mode = TM2
Test Channel = LCH/HCH

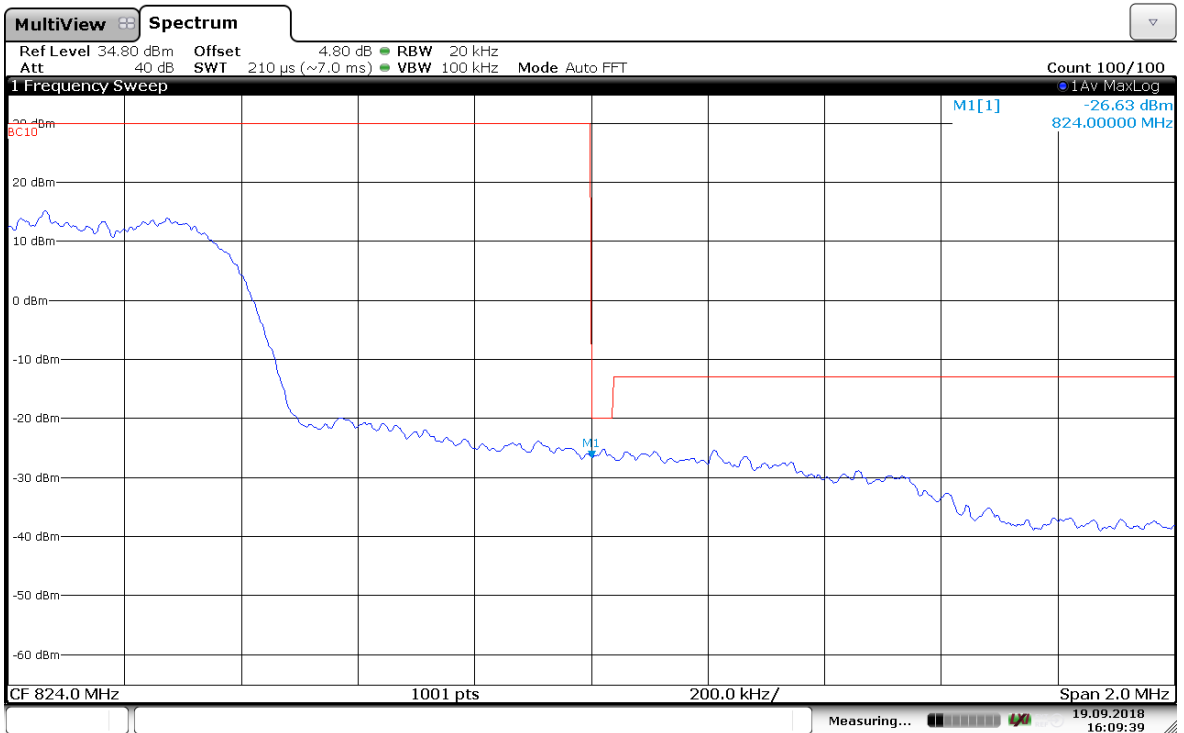
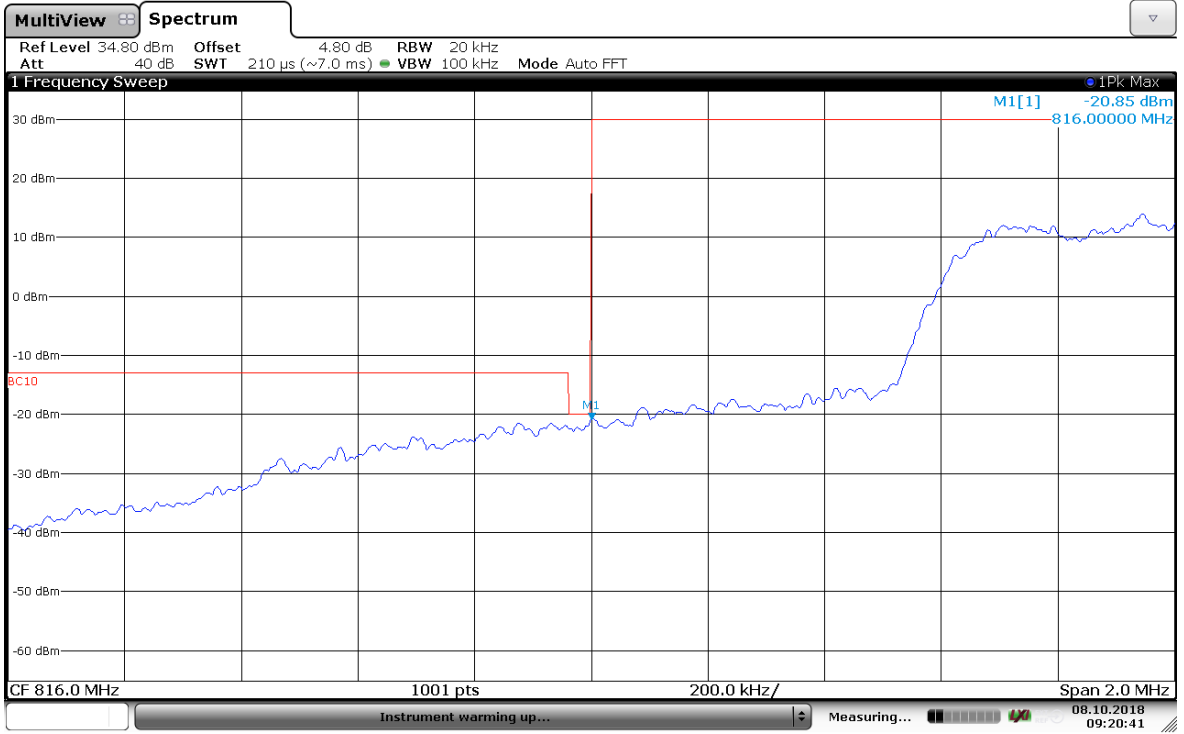



Band edge measurement
Test Band = 1xRTT –BC0 CELL Band
Test Mode = TM1
Test Channel = LCH/HCH

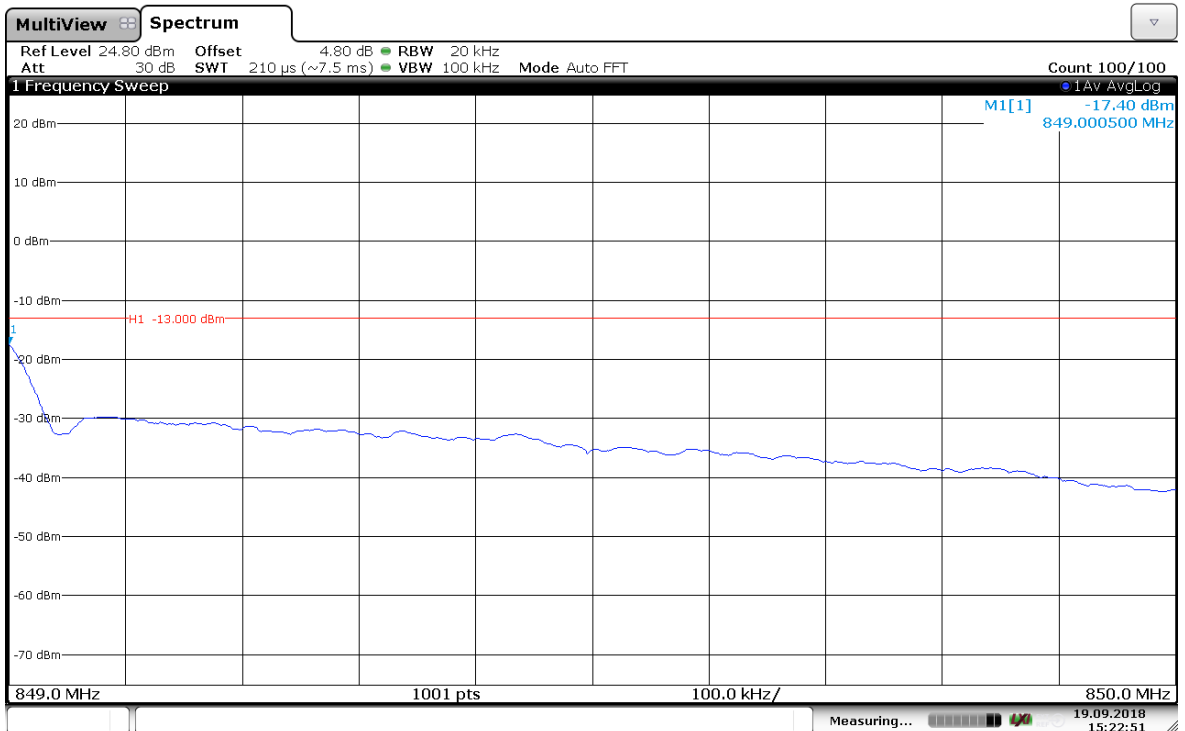
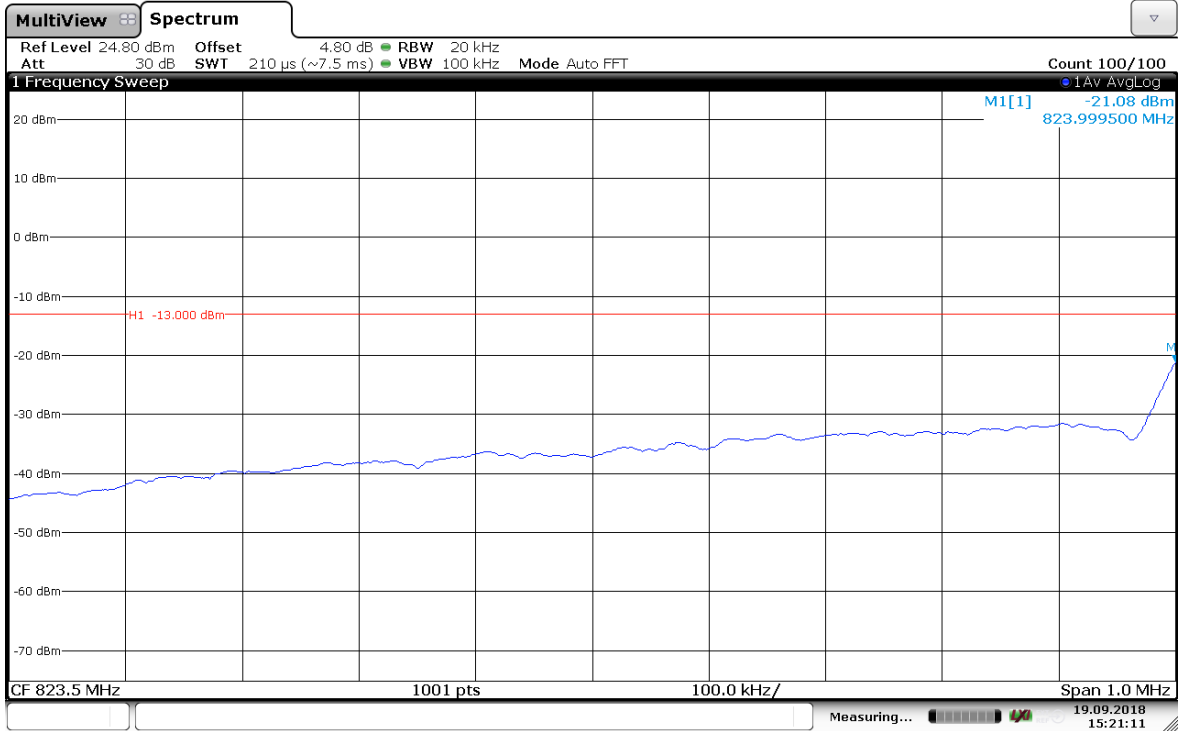



Band edge measurement
Test Band = 1xEV-DO -BC0 CELL Band
Test Mode = TM2
Test Channel = LCH/HCH

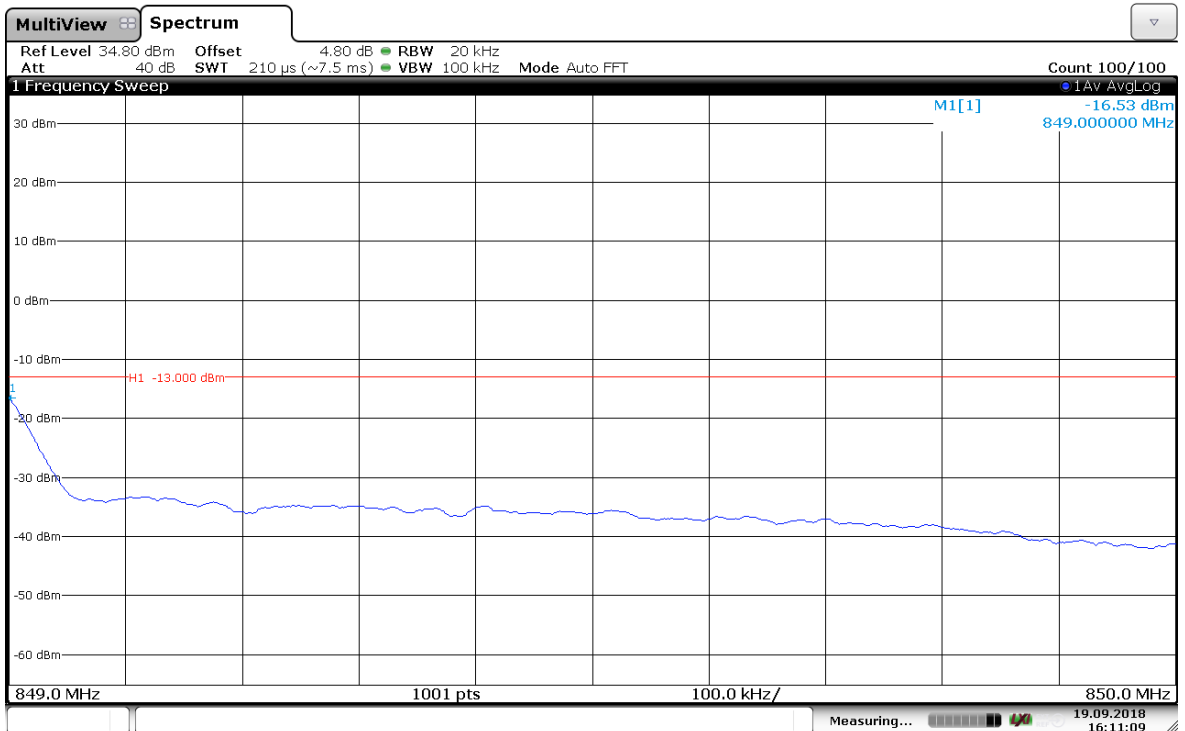
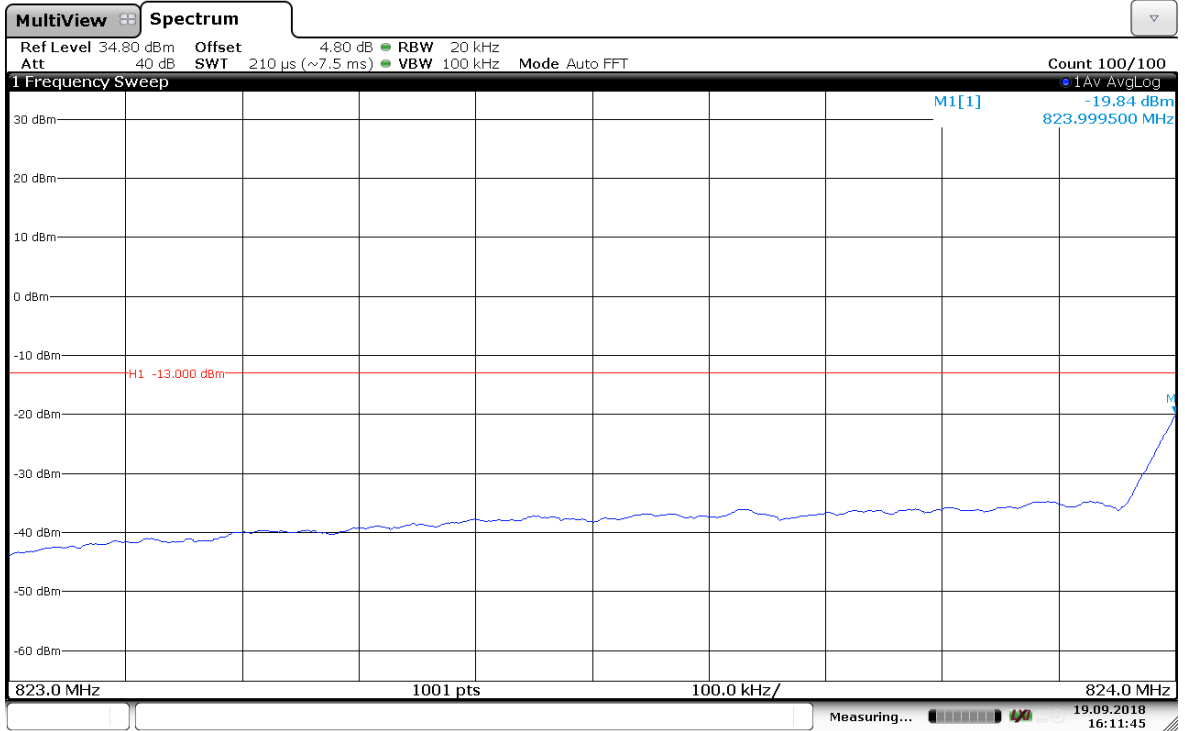

Out of band measurement
Test Band = 1xRTT – BC1 PCS Band
Test Mode = TM1
Test Channel = LCH/HCH

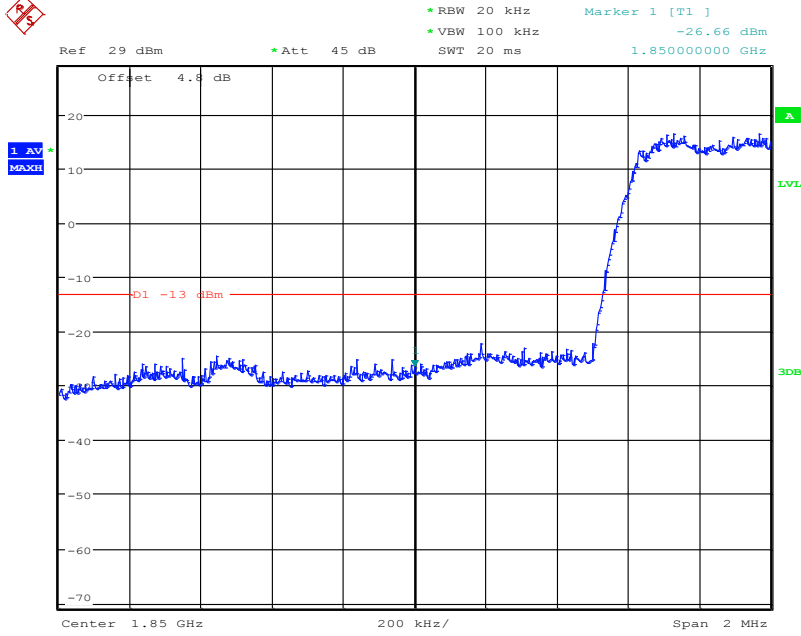

Date: 6.SEP.2018 16:17:03

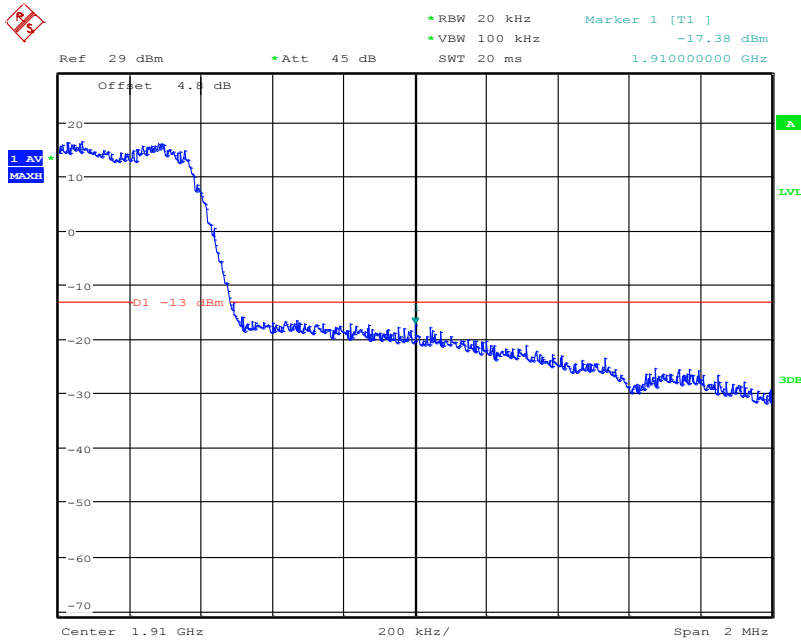

Date: 6.SEP.2018 16:18:37

Out of band measurement
Test Band = 1xEV-DO –BC1 PCS Band
Test Mode = TM2
Test Channel = LCH/HCH

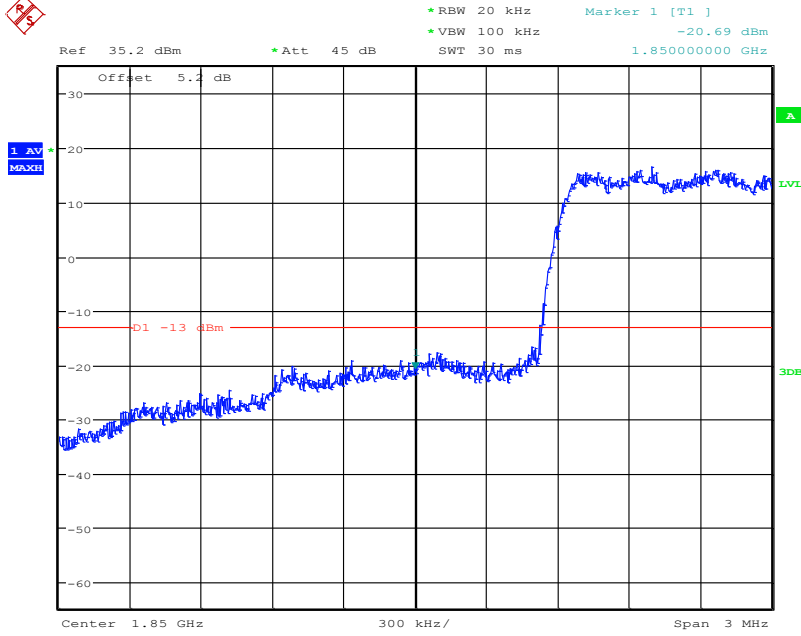

Date: 7.SEP.2018 10:16:52

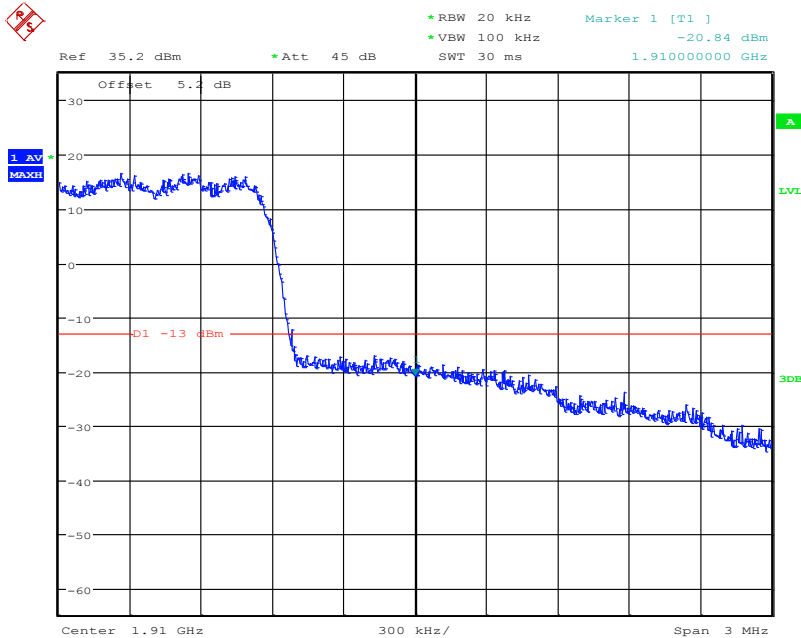

Date: 7.SEP.2018 10:16:17



5.5. Spurious Emissions Radiated

5.5.1. Test Standard

FCC: CFR Part 2.1053, CFR Part 22.917, CFR Part 24.238, CFR Part 90.210
IC : RSS-132§5.5, RSS-133§6.5, RSS-119§5.8

5.5.2. Test Limit

Measurements shall be made to detect spurious emissions that may be radiated directly from the cabinet, control circuits, power leads or intermediate circuit elements under normal conditions of installation and operation. Curves or equivalent data shall be supplied showing the magnitude of each harmonic and other spurious emission.

5.5.3. Limits:

(a) Out of band emissions. The power of any emission outside of the authorized operating frequency ranges must be attenuated below the transmitting power (P) by a factor of at least $43 + 10 \log(P)$ dB.

For all power levels +30dBm to 0dBm, this becomes a constant specification of -13dBm.

FCC 22.917 Emission limitations for cellular equipment.

The rules in this section govern the spectral characteristics of emissions in the Cellular Radiotelephone Service.

(b) Measurement procedure. Compliance with these provisions is based on the use of measurement instrumentation employing a resolution bandwidth of 100 kHz or greater. In the 1MHz bands immediately outside and adjacent to the frequency block a resolution bandwidth of at least one percent of the emission bandwidth of the fundamental emission of the transmitter may be employed. A narrower resolution bandwidth is permitted in all cases to improve measurement accuracy provided the measured power is integrated over the full required measurement bandwidth (i.e. 100 kHz of 1 percent of emission bandwidth, as specified). The emission bandwidth is defined as the width of the signal between two points, one below the carrier center frequency and one above the carrier center frequency, outside of which all emissions are attenuated at least 26 dB below the transmitter power.

FCC 24.238 Emission limitations for Broadband PCS equipment.

The rules in this section govern the spectral characteristics of emissions in the Broadband Personal Communications Service.

(b) Measurement procedure. Compliance with these provisions is based on the use of measurement instrumentation employing a resolution bandwidth of 1 MHz or greater. However, in the 1 MHz bands immediately outside and adjacent to the frequency block a resolution bandwidth of at least one percent of the emission bandwidth of the fundamental emission of the transmitter may be employed. A narrower resolution bandwidth is permitted in all cases to improve measurement accuracy provided the measured power is integrated over the full required measurement bandwidth (i.e. 100 kHz of 1 percent of emission bandwidth, as specified). The emission bandwidth is defined as the width of the signal between two points, one below the carrier center frequency and one above the carrier center frequency, outside of which all emissions are attenuated at least 26 dB below the transmitter power.



FCC 90.669 & RSS-119§5.8

(a) Out-of-band emission requirement shall apply only to the “outer” channels included in an EA license and to spectrum adjacent to interior channels used by incumbent licensees. The emission limits are as follows:

(1) For any frequency removed from the EA licensee's frequency block by up to and including 37.5 kHz, the power of any emission shall be attenuated below the transmitter power (P) in watts by at least $116 \text{ Log}_{10}(f/6.1)$ decibels or $50 + 10 \text{ Log}_{10}(P)$ decibels or 80 decibels, whichever is the lesser attenuation, where f is the frequency removed from the center of the outer channel in the block in kilohertz and where f is greater than 12.5 kHz.

(2) For any frequency removed from the EA licensee's frequency block greater than 37.5 kHz, the power of any emission shall be attenuated below the transmitter power (P) in watts by at least $43 + 10 \text{ Log}_{10}(P)$ decibels or 80 decibels, whichever is the lesser attenuation, where f is the frequency removed from the center of the outer channel in the block in kilohertz and where f is greater than 37.5 kHz.

RSS-132§5.5: Mobile and base station equipment shall comply with the limits in (i) and (ii) below.

(i) In the first 1.0 MHz band immediately outside and adjacent to each of the sub-bands specified in Section 5.1, the power of emissions per any 1% of the occupied bandwidth shall be attenuated (in dB) below the transmitter output power P (dBW) by at least $43 + 10 \log_{10} p$ (watts).

(ii) After the first 1.0 MHz immediately outside and adjacent to each of the sub-bands, the power of emissions in any 100 kHz bandwidth shall be attenuated (in dB) below the transmitter output power P (dBW) by at least $43 + 10 \log_{10} p$ (watts). If the measurement is performed using 1% of the occupied bandwidth, power integration over 100 kHz is required.

RSS-133§6.5 Equipment shall comply with the limits in (i) and (ii) below.

(i) In the 1.0 MHz bands immediately outside and adjacent to the equipment's operating frequency block, the emission power per any 1% of the emission bandwidth shall be attenuated (in dB) below the transmitter output power P (dBW) by at least $43 + 10 \log_{10} p$ (watts).

(ii) After the first 1.0 MHz, the emission power in any 1 MHz bandwidth shall be attenuated (in dB) below the transmitter output power P (dBW) by at least $43 + 10 \log_{10} p$ (watts). If the measurement is performed using 1% of the emission bandwidth, power integration over 1.0 MHz is required.

5.5.4. Test Procedure

1. Connect the equipment as shown in the above diagram with the EUT's antenna in a horizontal orientation.
2. Adjust the settings of the Universal Radio Communication Tester (CMU) to set the EUT to its maximum power at the required channel.
3. Set the spectrum analyzer to measure peak hold with the required settings.
4. Place the measurement antenna in a horizontal orientation. Rotate the EUT 360 .

Raise the measurement antenna up to 4 meters in 0.5 meters increments and rotate the EUT 360 at each height to maximize all emissions. Measure and record all spurious emissions (LVL) up to the tenth harmonic of the carrier frequency.

5. Replace the EUT with a horizontally polarized half wave dipole or known gain

antenna. The center of the antenna should be at the same location as the center of the EUT's antenna.

6. Connect the antenna to a signal generator with known output power and record the path loss in dB (LOSS). $LOSS = \text{Generator Output Power (dBm)} - \text{Analyzer reading (dBm)}$.

7. Determine the level of spurious emissions using the following equation:
 $\text{Spurious (dBm)} = \text{LVL (dBm)} + \text{LOSS (dB)}$:

8. Repeat steps 4, 5 and 6 with all antennas vertically polarized.

9. Determine the level of spurious emissions using the following equation:
 $\text{Spurious (dBm)} = \text{LVL (dBm)} + \text{LOSS (dB)}$:

10. Measurements are to be performed with the EUT set to the low, middle and high channel of each frequency band.

(Note: Steps 5 and 6 above are performed prior to testing and LOSS is recorded by test software. Steps 3, 4 and 7 above are performed with test software.)

Spectrum analyzer settings: RBW=VBW=1MHz

5.5.5. Test Setup

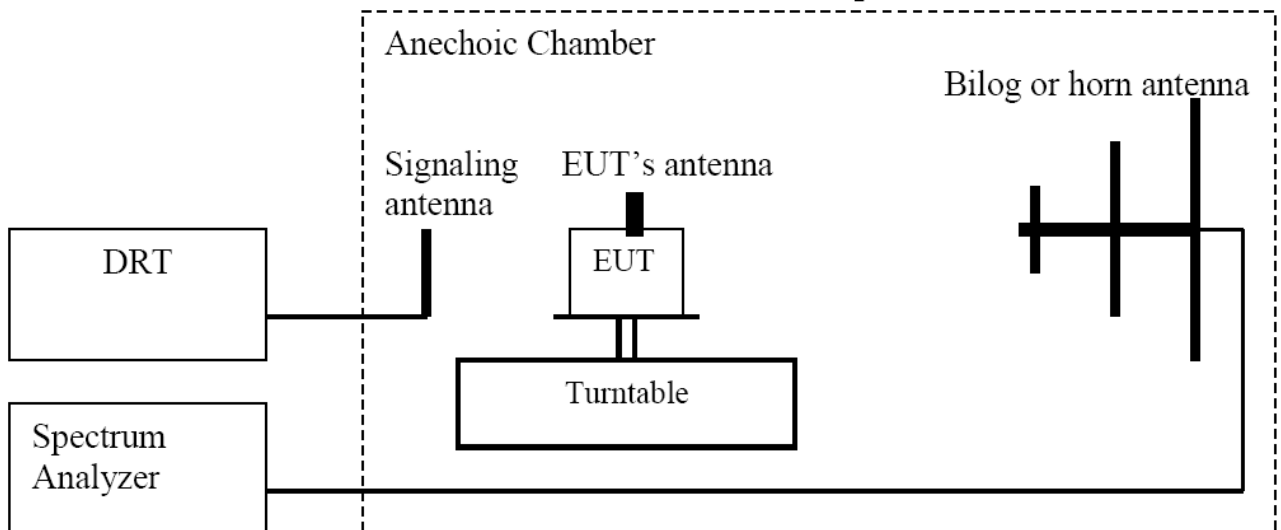



5.5.6.Test Data

Test Band = 1xRTT – BC10 SECONDARY 800
Test Mode = TM1
Test Channel = MCH

Freq.	SG. Level	Cable Loss	Antenna Gain	Preamp	Polarization	Substitution	Limit
[MHz]	[dBm]	[dB]	[dBi]	dB		Level (EIRP)	[dBm]
						[dBm]	
1640	-6.07	0.9	6.77	40.6	V	-40.8	-13

No other emissions were detected above system noise floor

Note: both of Vertical and Horizontal polarization are evaluated, and only the worst case is recorded in this report

Test Band = 1xEV-DO – BC10 SECONDARY 800
Test Mode = TM2
Test Channel = MCH

Freq.	SG. Level	Cable Loss	Antenna Gain	Preamp	Polarization	Substitution	Limit
[MHz]	[dBm]	[dB]	[dBi]	dB		Level (EIRP)	[dBm]
						[dBm]	
1640	-6.47	0.9	6.77	40.6	V	-41.2	-13

No other emissions were detected above system noise floor

Note: both of Vertical and Horizontal polarization are evaluated, and only the worst case is recorded in this report

Test Band = 1xRTT –BC0 CELL Band
Test Mode = TM1
Test Channel = MCH

Freq.	SG. Level	Cable Loss	Antenna Gain	Preamp	Polarization	Substitution	Limit
[MHz]	[dBm]	[dB]	[dBi]	dB		Level (EIRP)	[dBm]
						[dBm]	
1673.04	-6.17	0.9	6.77	40.6	V	-40.9	-13

No other emissions were detected above system noise floor

Note: both of Vertical and Horizontal polarization are evaluated, and only the worst case is recorded in this report



Test Band = 1xEV-DO –BC0 CELL Band
Test Mode = TM2
Test Channel = MCH

Freq.	SG. Level	Cable Loss	Antenna Gain	Preamp	Polarization	Substitution	Limit
[MHz]	[dBm]	[dB]	[dBi]	dB		Level (EIRP)	[dBm]
						[dBm]	
1673.04	-5.56	4.6	9.53	39	V	-39.63	-13

No other emissions were detected above system noise floor

Note: both of Vertical and Horizontal polarization are evaluated, and only the worst case is recorded in this report

Test Band = 1xRTT – BC1 PCS Band
Test Mode = TM1
Test Channel = MCH

Freq.	SG. Level	Cable Loss	Antenna Gain	Preamp	Polarization	Substitution	Limit
[MHz]	[dBm]	[dB]	[dBi]	dB		Level (EIRP)	[dBm]
						[dBm]	
3760	-6.53	4.6	9.53	39	V	-41.6	-13

No other emissions were detected above system noise floor

Note: both of Vertical and Horizontal polarization are evaluated, and only the worst case is recorded in this report

Test Band = 1xEV-DO –BC1 PCS Band
Test Mode = TM2
Test Channel = MCH

Freq.	SG. Level	Cable Loss	Antenna Gain	Preamp	Polarization	Substitution	Limit
[MHz]	[dBm]	[dB]	[dBi]	dB		Level (EIRP)	[dBm]
						[dBm]	
3760	-7.13	4.6	9.53	39	V	-41.2	-13

No other emissions were detected above system noise floor

Note: both of Vertical and Horizontal polarization are evaluated, and only the worst case is recorded in this report



5.6. Frequency Stability

5.6.1. Test Standard

FCC:CFR part 2.1055, CFR Part 22.355 , CFR Part 24.235, CFR Part 90.213
IC:RSS132§5.3, RSS133§6.3, RSS-119§5.3

5.6.2. Test Limit

FCC 22.355, from 821MHz to 896MHz, for mobile device, the carrier frequency of each transmitter in the Public Mobile Services must be maintained within the tolerances 2.5ppm.

FCC 24.235 The frequency stability shall be sufficient to ensure that the fundamental emission stays within the authorized frequency block.

FCC 90.213, The carrier frequency shall not depart from the reference frequency in excess of ± 2.5 ppm for mobile stations.

RSS132§5.3, The carrier frequency shall not depart from the reference frequency in excess of ± 2.5 SRSP for mobile stations and ± 1.5 ppm for base stations. In lieu of meeting the above stability values, the test report may show that the frequency stability is sufficient to ensure that the occupied bandwidth stays within each of the sub-bands (see Section 5.1) when tested to the temperature and supply voltage variations specified in RSS-Gen.

RSS133§6.3, The carrier frequency shall not depart from the reference frequency, in excess of ± 2.5 ppm for mobile stations and ± 1.0 ppm for base stations. In lieu of meeting the above stability values, the test report may show that the frequency stability is sufficient to ensure that the emission bandwidth stays within the operating frequency block when tested to the temperature and supply voltage variations specified in RSS-Gen.

RSS-119§5.3, For 06-821/851-866 and 821-824/866- 869 MHz The carrier frequency shall not depart from the reference frequency in excess of ± 2.5 ppm for mobile stations.

5.6.3. Test Procedure

In order to measure the carrier frequency under the condition of AFC lock, it is necessary to make measurements with the EUT in a “call mode”. This is accomplished with the use of R&S CMU 200 Universal Radio Communication Tester.

1. Measure the carrier frequency at room temperature.
2. Subject the EUT to overnight soak at -30 C.
3. With the EUT, powered via nominal voltage, connected to the CMU 200 and in a simulated call on mid channel, measure the carrier frequency. These measurements should be made within 2 minutes of powering up the EUT, to prevent significant self-warming.
4. Repeat the above measurements at 10 C increments from -30 C to +50 C. Allow at least 1 1/2 hours at each temperature, un-powered, before making measurements.
5. Re-measure carrier frequency at room temperature with nominal voltage. Re-measure carrier frequency at low and high voltage. Pause at nominal voltage for 1 1/2 hours un-powered, to allow any self-heating to stabilize, before continuing.
6. Subject the EUT to overnight soak at +50 C.
7. With the EUT, powered via nominal voltage, connected to the CMU 200 and in a



simulated call on mid channel (560 for BC10 SECONDARY 800 ,384 for BC0 CELL Band & 600 for BC1 PCS Band), measure the carrier frequency. These measurements should be made within 2 minutes of powering up the EUT, to prevent significant self-warming.

8. Repeat the above measurements at 10 C increments from +50 C to -30 C. Allow at least 1 1/2 hours at each temperature, un-powered, before making measurements.

9. At all temperature levels hold the temperature to +/- 0.5 C during the measurement procedure.

5.6.4.Test Setup

Connect the EUT to the Wireless Communication test set CMU200 via the connector. Then measure the frequency error by the Wireless Communication test set CMU200. The EUT's output is matched with a 50 Ω load.

5.6.5.Test Data

Measurement Results vs. Variation of Temperature—1xRTT – BC10 SECONDARY 800

Temperature	Nominal Frequency (MHz)	Measured Frequency Error(Hz)	Result
-30 ℃	820	22	Pass
-20 ℃	820	21	Pass
-10 ℃	820	27	Pass
0 ℃	820	-19	Pass
+10 ℃	820	-23	Pass
+20 ℃	820	-19	Pass
+30 ℃	820	23	Pass
+40 ℃	820	21	Pass
+50 ℃	820	-27	Pass

Measurement Results vs. Variation of Voltage—1xRTT – BC10 SECONDARY 800

Voltage	Nominal Frequency (MHz)	Measured Frequency Error(Hz)	Result
3.5 V	820	-17	Pass
3.8 V	820	19	Pass
4.2V	820	26	Pass



Measurement Results vs. Variation of Temperature—1xEV-DO – BC10 SECONDARY 800

Temperature	Nominal Frequency (MHz)	Measured Frequency Error(Hz)	Result
-30 ℃	820	32	Pass
-20 ℃	820	-21	Pass
-10 ℃	820	13	Pass
0 ℃	820	25	Pass
+10 ℃	820	15	Pass
+20 ℃	820	9	Pass
+30 ℃	820	-17	Pass
+40 ℃	820	-14	Pass
+50 ℃	820	-22	Pass

Measurement Results vs. Variation of Voltage—1xEV-DO – BC10 SECONDARY 800

Voltage	Nominal Frequency (MHz)	Measured Frequency Error(Hz)	Result
3.5 V	820	16	Pass
3.8 V	820	13	Pass
4.2V	820	24	Pass



Measurement Results vs. Variation of Temperature—1xRTT –BC0 CELL Band

Temperature	Nominal Frequency (MHz)	Measured Frequency Error(Hz)	Result
-30 ℃	836.52	17	Pass
-20 ℃	836.52	31	Pass
-10 ℃	836.52	-25	Pass
0 ℃	836.52	20	Pass
+10 ℃	836.52	23	Pass
+20 ℃	836.52	14	Pass
+30 ℃	836.52	-22	Pass
+40 ℃	836.52	9	Pass
+50 ℃	836.52	-18	Pass

Measurement Results vs. Variation of Voltage—1xRTT –BC0 CELL Band

Voltage	Nominal Frequency (MHz)	Measured Frequency Error(Hz)	Result
3.5 V	836.52	11	Pass
3.8 V	836.52	29	Pass
4.2V	836.52	-18	Pass



Measurement Results vs. Variation of Temperature – 1xEV-DO –BC0 CELL Band

Temperature	Nominal Frequency (MHz)	Measured Frequency Error(Hz)	Result
-30 ℃	836.52	-17	Pass
-20 ℃	836.52	-24	Pass
-10 ℃	836.52	-21	Pass
0 ℃	836.52	22	Pass
+10 ℃	836.52	-19	Pass
+20 ℃	836.52	-24	Pass
+30 ℃	836.52	20	Pass
+40 ℃	836.52	-17	Pass
+50 ℃	836.52	-13	Pass

Measurement Results vs. Variation of Voltage – 1xEV-DO –BC0 CELL Band

Voltage	Nominal Frequency (MHz)	Measured Frequency Error(Hz)	Result
3.5 V	836.52	19	Pass
3.8 V	836.52	-24	Pass
4.2V	836.52	-29	Pass



Measurement Results vs. Variation of Temperature—1xRTT – BC1 PCS Band

Temperature	Nominal Frequency (MHz)	Measured Frequency Error(Hz)	Result
-30 ℃	1880.0	22	Pass
-20 ℃	1880.0	28	Pass
-10 ℃	1880.0	-17	Pass
0 ℃	1880.0	-24	Pass
+10 ℃	1880.0	-31	Pass
+20 ℃	1880.0	17	Pass
+30 ℃	1880.0	23	Pass
+40 ℃	1880.0	13	Pass
+50 ℃	1880.0	8	Pass

Measurement Results vs. Variation of Voltage—1xRTT – BC1 PCS Band

Voltage	Nominal Frequency (MHz)	Measured Frequency Error(Hz)	Result
3.5 V	1880.0	8	Pass
3.8 V	1880.0	16	Pass
4.2V	1880.0	22	Pass



Measurement Results vs. Variation of Temperature—1xEV-DO –BC1 PCS Band

Temperature	Nominal Frequency (MHz)	Measured Frequency Error(Hz)	Result
-30 ℃	1880.0	21	Pass
-20 ℃	1880.0	17	Pass
-10 ℃	1880.0	-25	Pass
0 ℃	1880.0	22	Pass
+10 ℃	1880.0	28	Pass
+20 ℃	1880.0	16	Pass
+30 ℃	1880.0	11	Pass
+40 ℃	1880.0	-16	Pass
+50 ℃	1880.0	-20	Pass

Measurement Results vs. Variation of Voltage—1xEV-DO –BC1 PCS Band

Voltage	Nominal Frequency (MHz)	Measured Frequency Error(Hz)	Result
3.5 V	1880.0	21	Pass
3.8 V	1880.0	-24	Pass
4.2V	1880.0	-16	Pass