



## IMPORTANT



Be Sure  
to Read this  
Manual  
Before Use



UNIS TECHNOLOGY

# Operation Manual

# WE ARE HERE TO ASSIST For parts and service



Have Questions? Contact us!

## UNIS SERVICE CENTER

Tel: 972-241-4263

Email: [service@unispartsandservice.com](mailto:service@unispartsandservice.com)

<b>NAME:</b> TICKET DOME RFID GMP	<b>MAX POWER:</b> 350W
<b>MODEL:</b> T-351	<b>MIN POWER:</b> 240W
<b>S/N:</b>	<b>FREQUENCY:</b> 50/60Hz
<b>VOLTAGE:</b> AC110	<b>DATE:</b>
<b>Guangdong UNIS Technology Co.,Ltd.</b>	

<b>NAME:</b> TICKET DOME RFID GMP	<b>MAX POWER:</b> 350W
<b>MODEL:</b> T-351	<b>MIN POWER:</b> 240W
<b>S/N:</b>	<b>FREQUENCY:</b> 50/60Hz
<b>VOLTAGE:</b> AC220V-240V	<b>DATE:</b>
<b>Guangdong UNIS Technology Co.,Ltd.</b>	

# CONTENT

- IMPORTANT SAFETY INSTRUCTIONS.....3
- 1. SPECIFICATIONS.....5
- 2. CONTENTS OF THE ACCESSORY KIT..... 6
- 3. PART NAME.....7
- 4. SET UP & INSTALLATION..... 8
- 5. HOW TO PLAY.....16
- 6. GAME OPTION..... 17
- 7. TROUBLESHOOTING.....25
- 8. MAINTENANCE & INSPECTION.....25
- 9. OVERALL CONSTRUCTION..... 26
- 10. WIRING DIAGRAM.....37

Thank you for purchasing **Ticket Dome RFID**. We hope you enjoy the product.

This manual contains valuable information about how to operate and maintain your game machine properly and safely. It is intended for the owner and/or personnel in charge of product operation. Carefully read and understand the instructions.

If you need any help during installation and setup please utilize this manual and troubleshooting guide. If the product fails to function properly, *non-technical personnel should under no circumstance attempt to service the machine*. Contact your distributor or manufacturer for help.

Before use, please read **IMPORTANT SAFETY INSTRUCTIONS**.

## IMPORTANT SAFETY INSTRUCTIONS

**To ensure the safe usage of this product, carefully read and understand these instructions before operating your game.**

**Save these instructions for future reference.**

Use this product only as described in this manual. Other uses not recommended may cause fire, electric shock or personal injury. Unplug the game from the outlet when not in use, when moving from one location to another, and before cleaning/servicing.

Explanations which require special attention are indicated by signs of warning. Depending on the potential hazardous degree, the terms: **NOTE**, **NOTICE**, and **WARNING** are used.

**NOTE:** A NOTE indicates useful hints or information about product usage.

**NOTICE:** A NOTICE indicates potential damage to product and how to avoid the problem.

**WARNING:** A WARNING indicates a potential for product damage or serious personal injury.

It is important to understand the meaning of the following HAZARD SIGNS before continuing:

### High Voltage and Shock Hazard:

High voltage can cause electric shock.  
Turn off/unplug power before servicing.



### High Temperature Hazard:

This part may cause scalding.  
Do not touch. Surface may be hot.



### No Touching Hazard:

This part may be hot or can cause electric shock.  
Do not touch.



Use the following safety guidelines to help ensure your own personal safety and to help protect your equipment and surrounding environment from potential damage.

**⚠️ This product is an indoor game machine. Do not install outdoors.**

Avoid installing in the following places to prevent fire, electric shock, injury and/or machine malfunctioning:

- Places subject to rain/moisture, or places subject to high humidity.
- Places subject to direct sunlight, or places subject to extremely hot or cold temperatures to ensure that it is used within the specified operating range.
- Places where inflammable gas may be present or in the vicinity of highly inflammable/volatile chemicals or items that can easily catch fire.
- On unstable or sloped surfaces. The machine may topple or cause unforeseen accidents.
- Vicinity of fire exits, fire extinguishers etc that may block/prevent safety measures.

**IMPORTANT NOTE:**

**ALL REPAIRS MUST BE DONE TO ORIGINAL MANUFACTURER SPECIFICATIONS. FAILURE TO DO SO VOID ALL WARRANTIES AND OPERATOR ASSUMES ALL RISKS.**

Note: The contents of this manual may be updated without notice.

# 1. SPECIFICATIONS

Rated power supply: AC110V 50/60Hz; AC220V 50/60Hz

Min. Power consumption: 240W

Max. Power consumption: 350W

Dimension:Width: 58.66" (1490mm)

Depth: 58.66" (1490mm)

Height: 56.92"(1446mm)

Weight: Approximately 380.37 lb (345kg)

Model No: T-351

 **NOTICE:** After turning off the game, please wait at least 1 minute before restarting again.

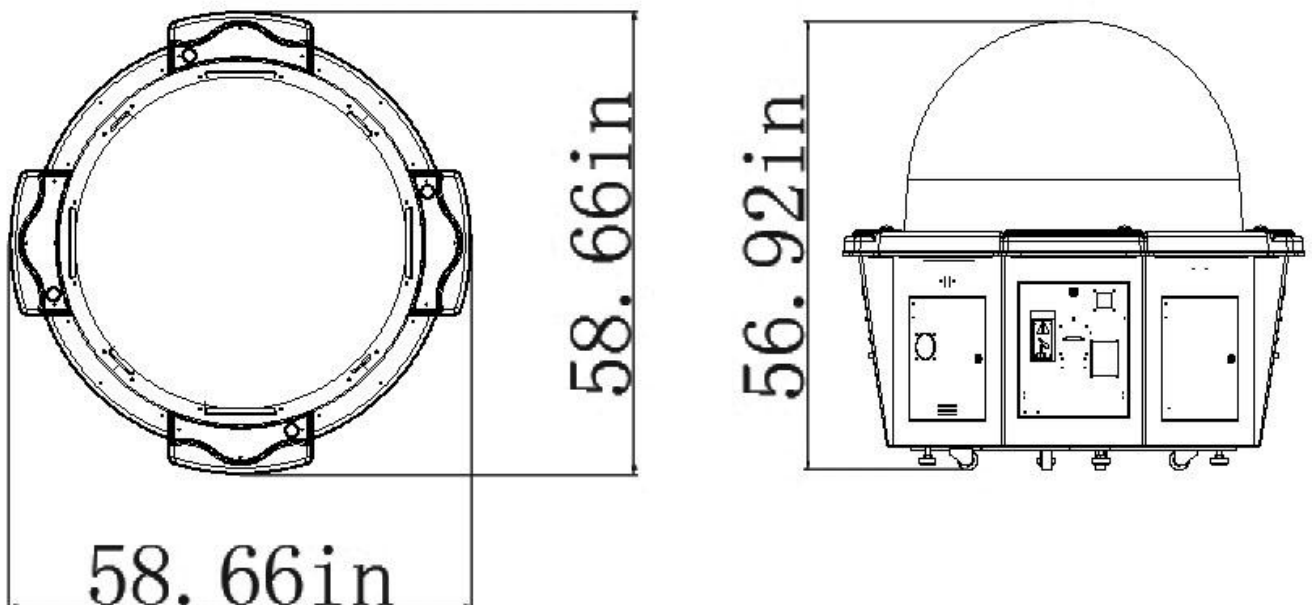

**Note:** Game specifications are subject to change without notice.

## 2. CONTENTS OF THE ACCESSORY KIT

Open the package and make sure all the items are included:

Following accessories

No.	Name	Spec.	Qty	Picture
1	Manual	English	1	
2	Key	171A	1	
3	Key	171B	1	
4	Power cord	1.8M	1	
5	Fuse	6.3A	1	
6	Micro Switch	D3V-6G-1C24	3	
7	Optical coupler	/	4	
8	Extended line	1.2M (Maintenance and use)	1	/

**NOTE:** Part models are subject to change without notice.

### 3. PART NAME

#### Key Components

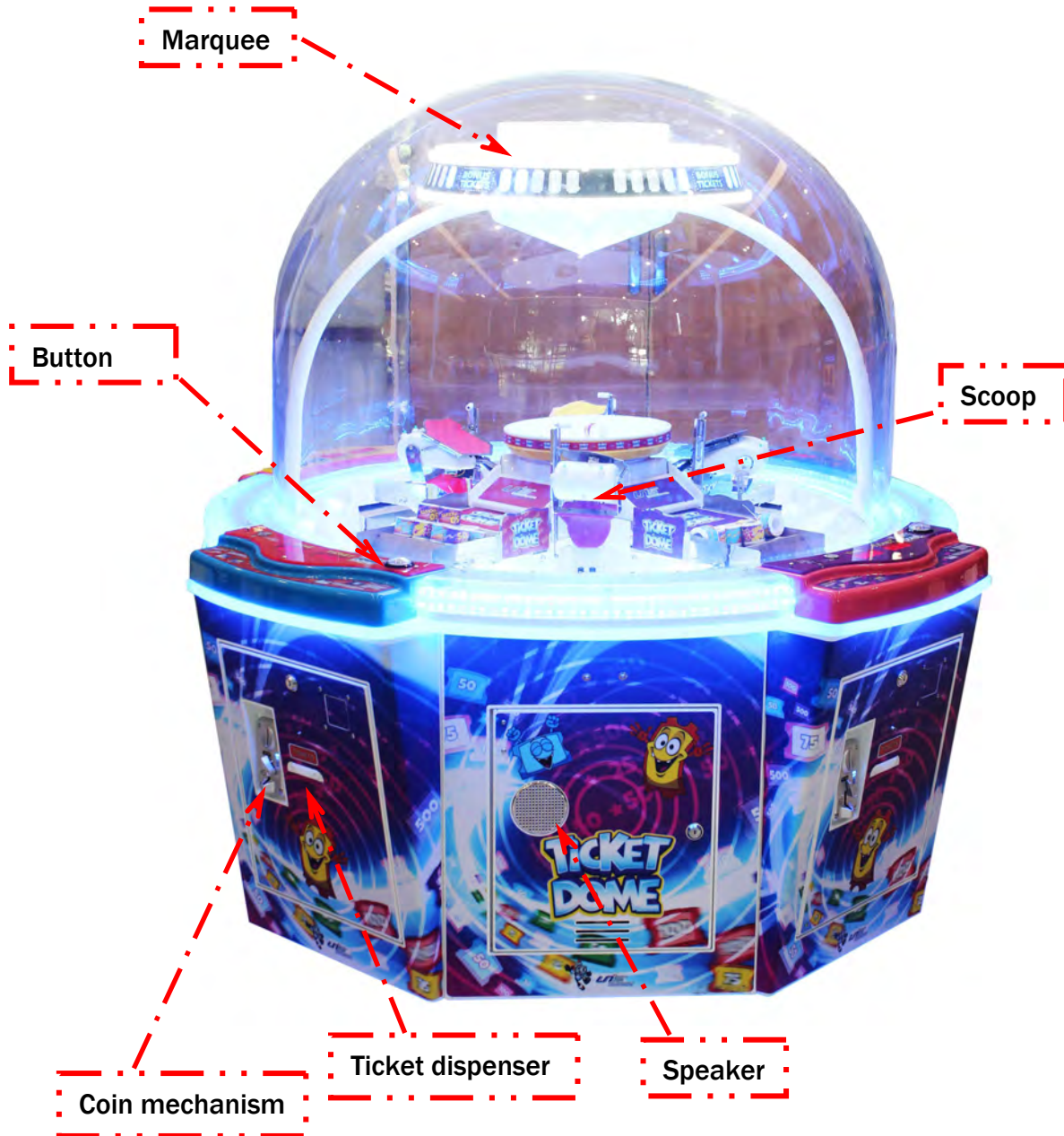



## 4. SET UP & INSTALLATION

### ! NOTICE

**We do not recommend using power tools as they may cause damage.**

**! This product is an indoor game machine. Do not install outdoors.**

- Refer to IMPORTANT SAFETY INSTRUCTIONS (Pg. 3) for places to avoid
- Place the unit on a dry level surface
- Ventilation openings in the back of the unit must not be obstructed by objects or by wall.

### 4.1 Transporting the Game

If you need to move the game, adjust the levelers back to an “up” position.

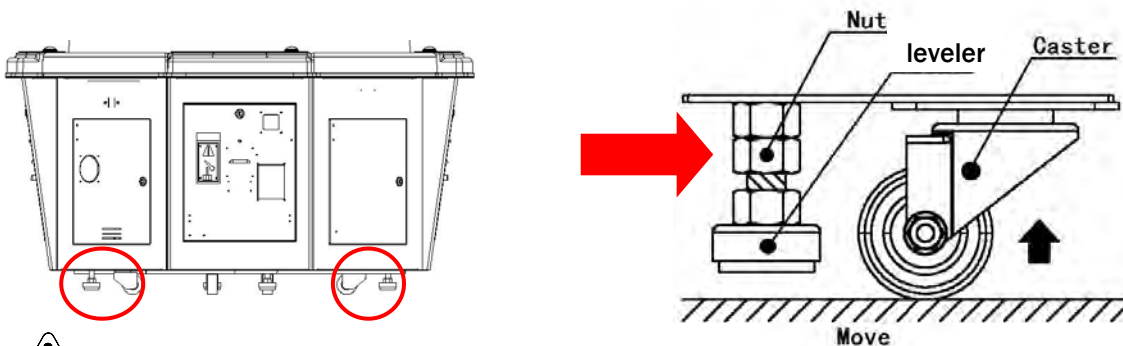

### ! NOTICE

- Be careful not to damage the machine during transport.
- Always unplug the game before moving.
- For longer distance transport, package the game properly to prevent damages.

**Please keep the machine in upright position during transport.**

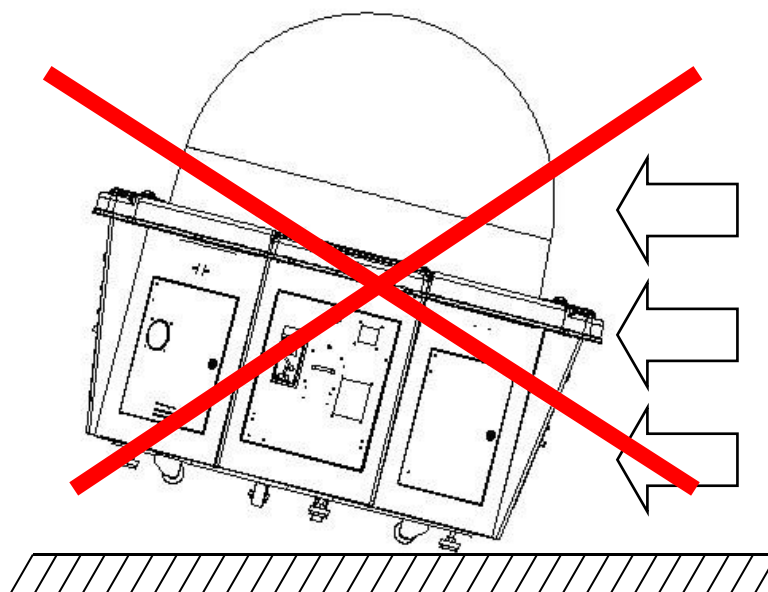

This procedure requires 4 people assistance.

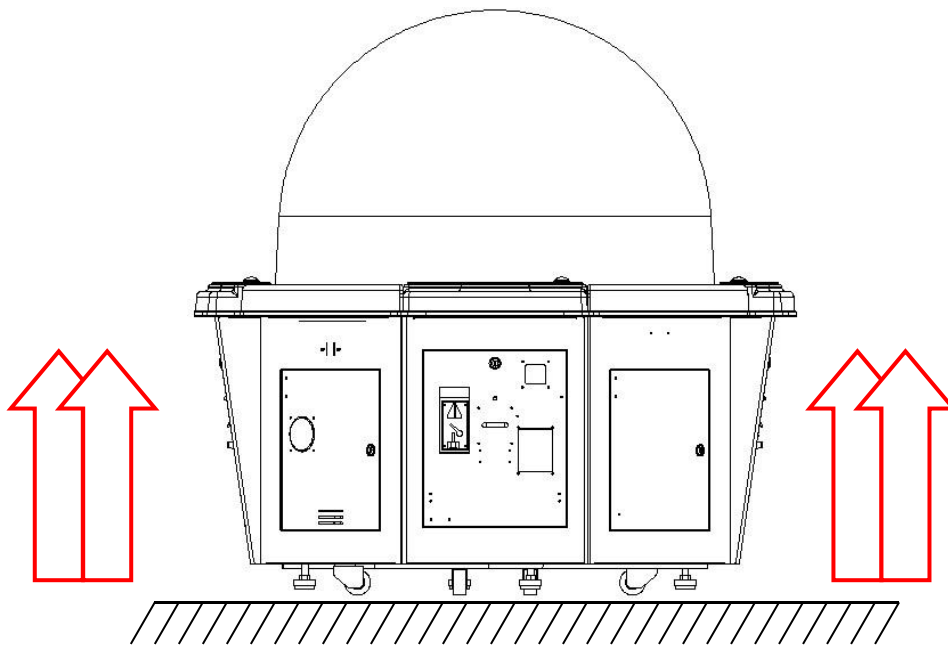

#### 4.2 Level Adjustment

Install this game on a flat surface. If the game is installed on an unsuitable floor, it could cause game malfunction.

To secure the game, loosen the nut, utilize wrench to adjust the leveler down until it touches the floor, lifting the casters off the ground by 0.2 in. Repeat the same for all levelers.

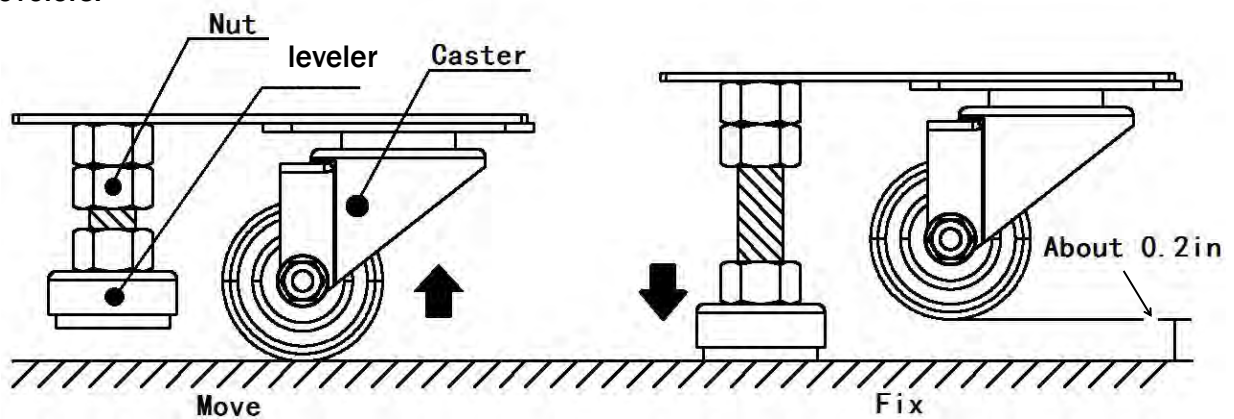

**! NOTICE**

**Make sure the machine is level.**

### 4.3 Play Zone



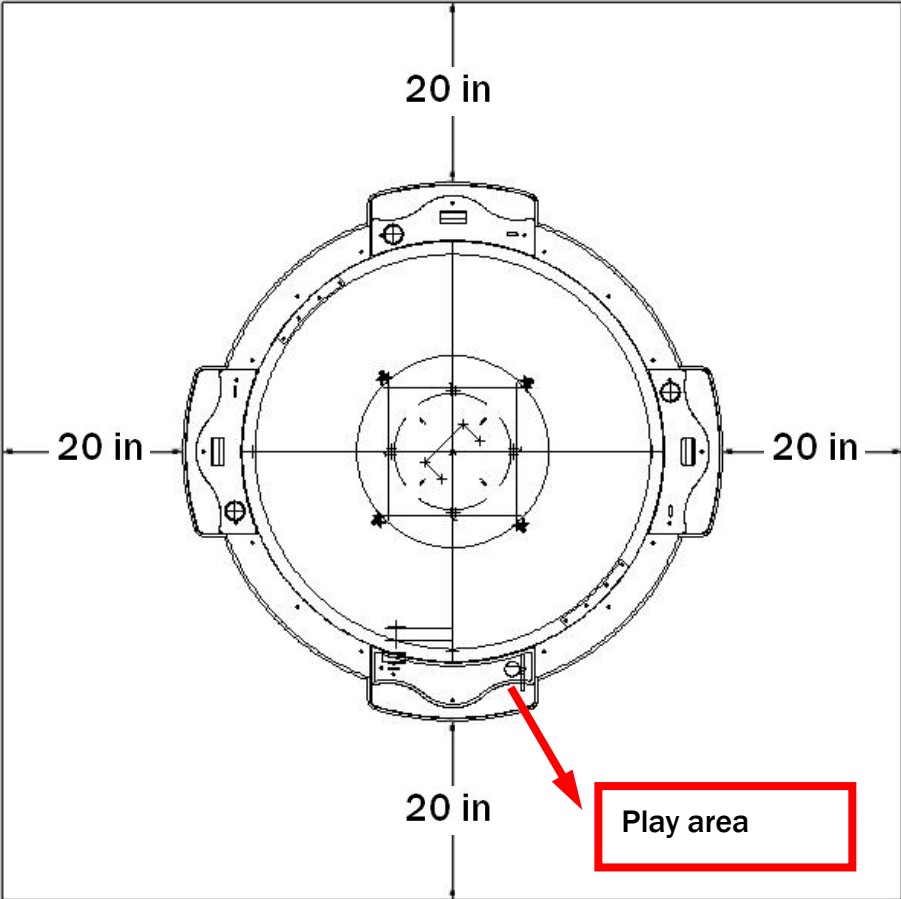

This machine requires space for playing and for maintenance as shown below. Leave space around the game upon installation:

Play area: 20 in



## 4.4 Machine Installation

Before processing, assure you have the following tools.

No	Name	Picture
1	Phillips screwdriver	
2	Socket wrench	
3	Allen wrench	
4	Spanner	

### Marquee Installation

Step 1 Utilize Allen wrench to loosen 8 screws to remove Marquee base plate.

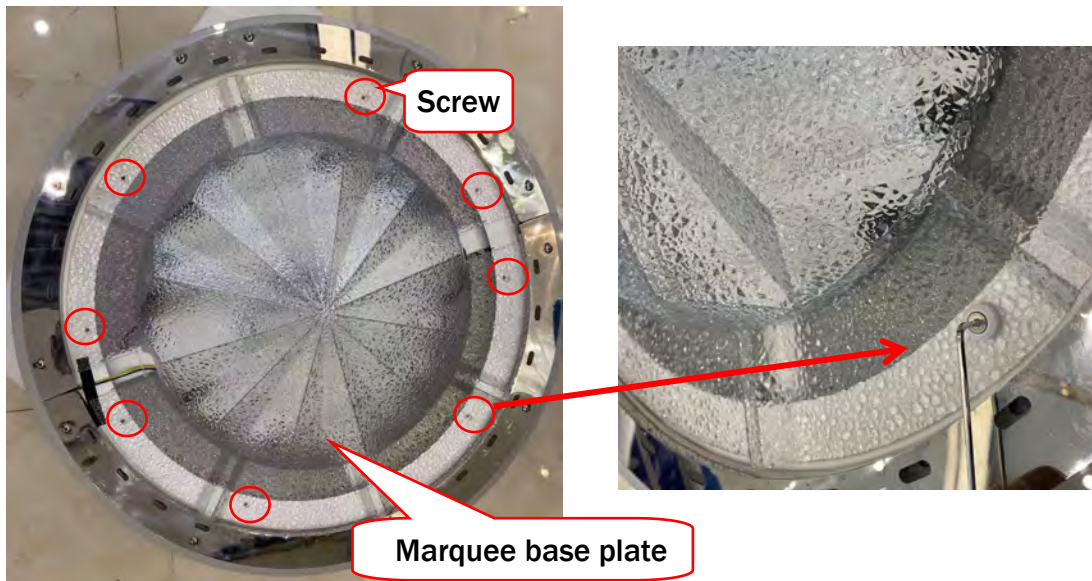

Step 2 Place Marquee support plate on the Marquee as indicated. Connect the 2 connector to Marquee.

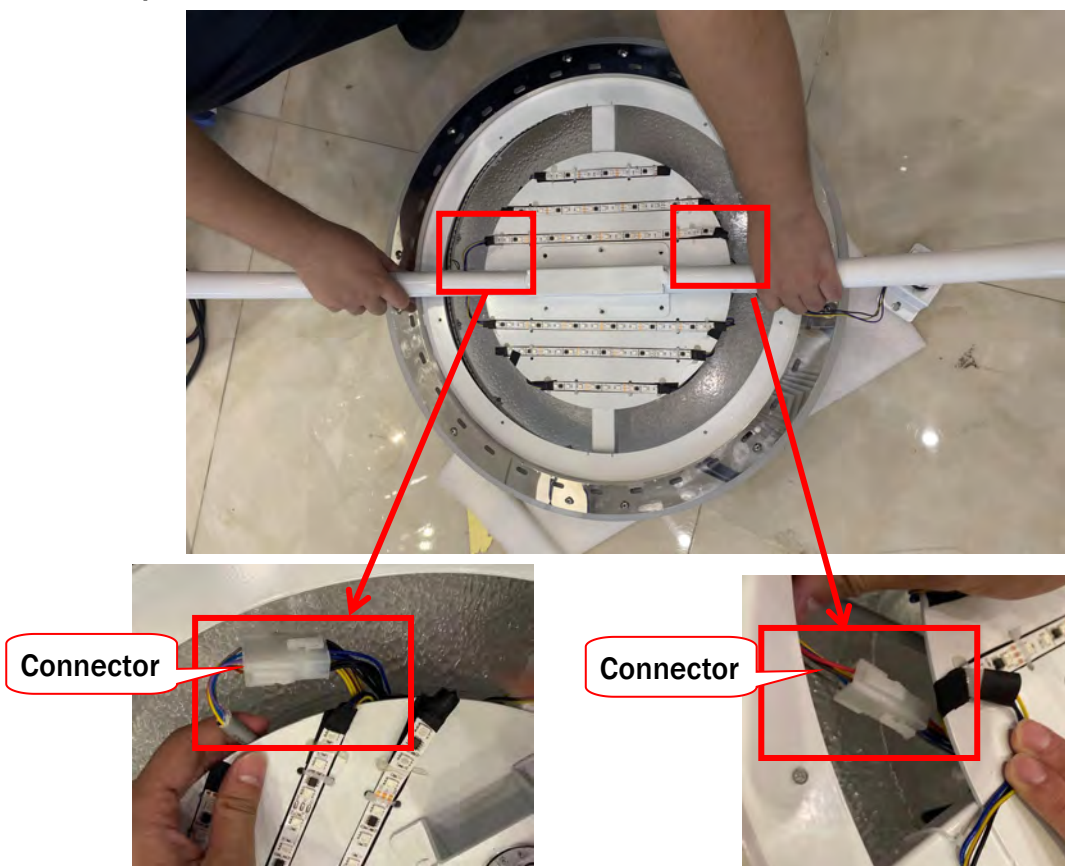

Step 3 Utilize Phillips screwdriver and Spanner to tighten 4 screws and nuts to the Marquee support plate.

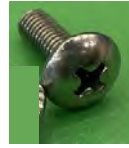
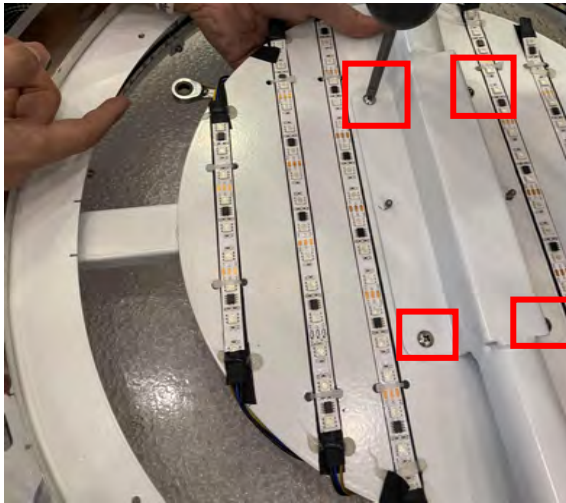

Name	Cross recessed pan head screw
SPEC	M5X10
Qty	4



Name	Flange nut
SPEC	M5
Qty	4

Step 4 Place Marquee bracket on the Marquee support plate. Utilize cable tie to tie the cable as indicated. Utilize Socket wrench to tighten 2 nuts to Marquee bracket.

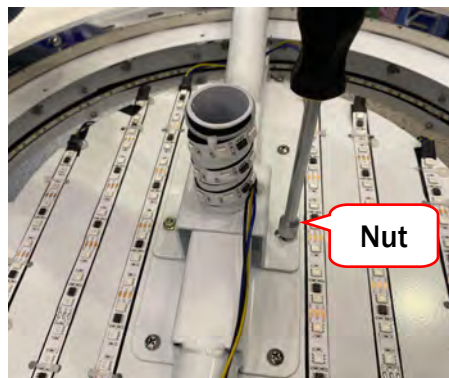
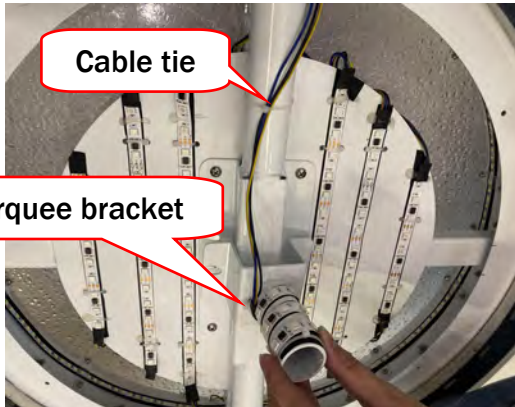

Name	Nut
SPEC	M5
Qty	2

Step 5 Place Marquee base plate back and utilize screws to tighten Marquee.

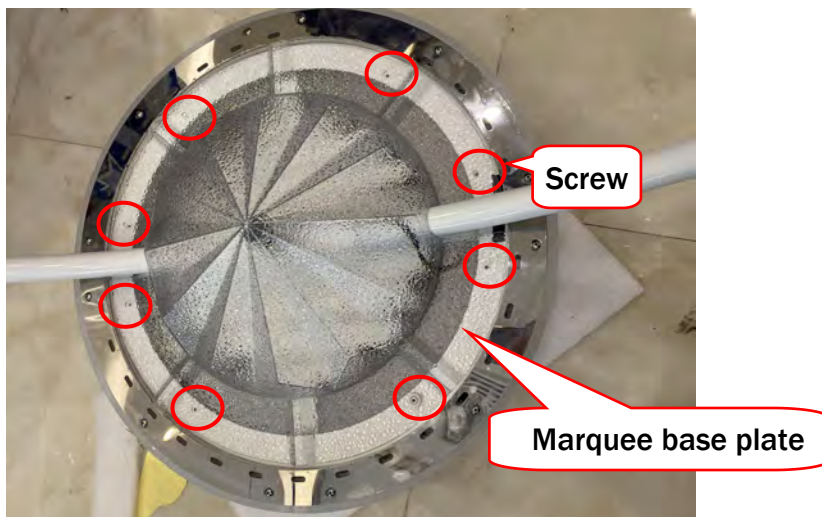

Step 6 Open the service door between Purple player and Blue player. Power on the machine. Turn the Switch to UP side.

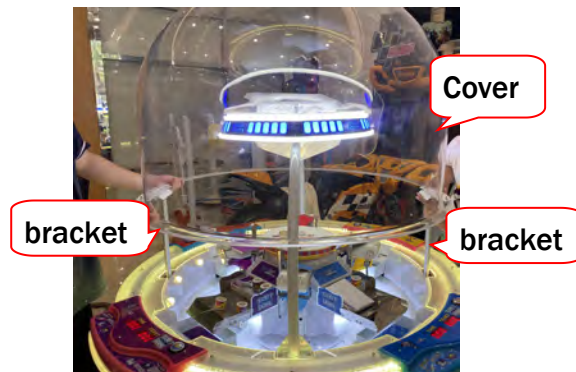

Step 7 Utilize Phillips screwdriver to loosen 2 screws and cotter pin to remove Cover.



Step 8 Place Marquee assembly on the machine as indicated. Open the Service door between Red player and Yellow player to connect the 8 port connector. Open the Service door between Blue player and Purple player to connect the 6 port connector.



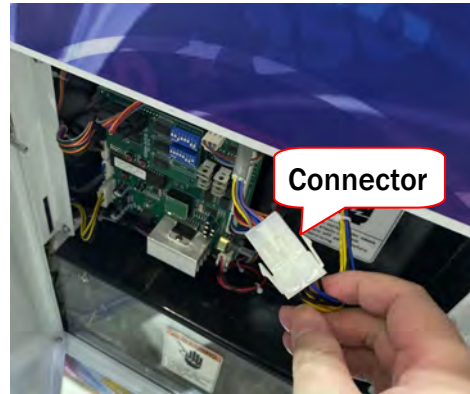

Step 9 Utilize Phillips screwdriver and Spanner to tighten 4 screws, 4 flange nuts, 4 spring washers, and 4 flat washers to Marquee support bracket.



Name	Cross recessed pan head screw
SPEC	M4×16
Qty	4



Name	Flange nut
SPEC	M4
Qty	4



Name	Spring washer
SPEC	Ø4
Qty	4



Name	Flat washer
SPEC	4×8
Qty	4

Step 10 The rest installation method of Marquee please refer to Step 6-Step 7 in reversed order.

## RFID Reader Installation

Step 1 Open the service door between Purple player and Blue player. Turn over the RFID reader and install it on the top of the M3 board as indicated.



RFID reader front side

Step 2 Connect 6 cables to the RFID reader. (J41 to ANT1; J41 to ANT2; J43 to ANT3; J44 to ANT4; J45 to ANT5;)

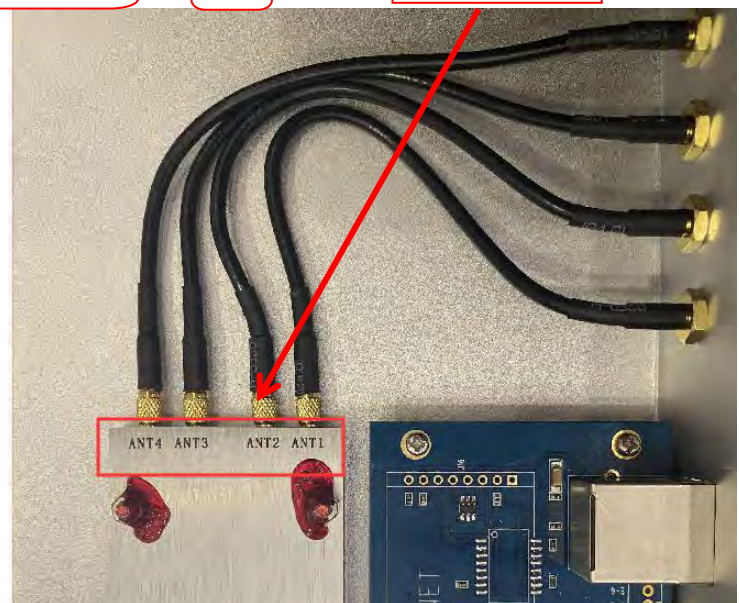
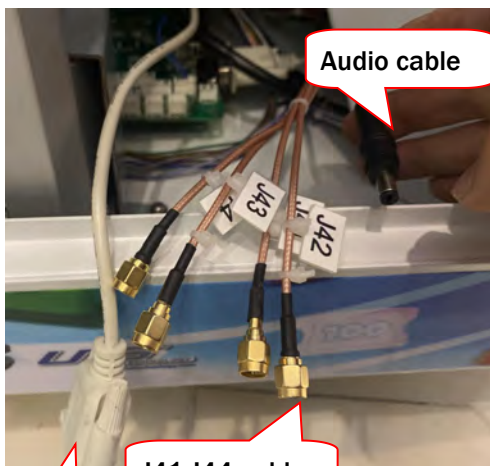

**Finish!**



## 5. HOW TO PLAY

- 1 Please insert coin(s) /swipe card to play.
- 2 Aim at prizes and press Button to scoop the prizes on the turn table.
- 3 Prizes drop down to be collected. This will activate the BONUS feature above.
- 4 Press Button to stop the spinning feature and try to land on “Win BONUS” for more prizes!

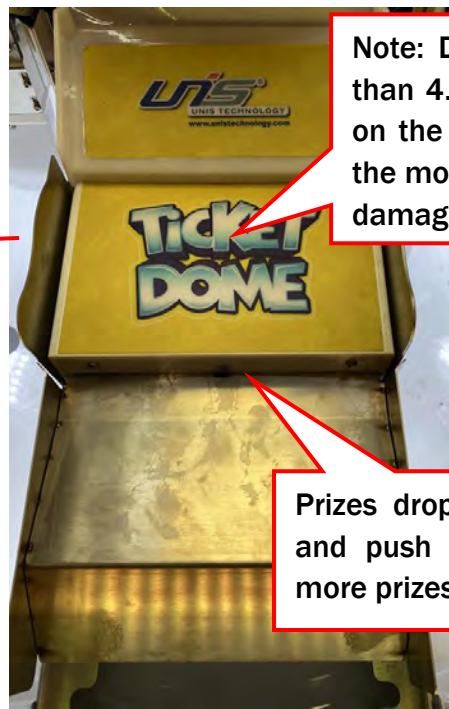

Note: Do not put more than 4.4lb prizes totally on the plate. Otherwise the motor will be damaged.

Prizes drop down and push to win more prizes.

## 6. GAME OPTION

### 6.1 Ticket Dome I/O chart:

Item	Value	SW1							
		1	2	3	4	5	6	7	8
Coin Per Game	1/4	off	off	off					
	1/3	on	off	off					
	1/2	off	on	off					
	1/1	on	on	off					
	2/1	off	off	on					
	3/1	on	off	on					
	4/1	off	on	on					
	5/1	on	on	on					
Scoop Times*	4				off	off			
	8				on	off			
	12				off	on			
	16				on	on			
Demo Music	NO						off		
	YES						on		
Game Mode	Normal							off	off
	Free Play							on	off
	Bonus							off	on
	Factory Restore							on	on

Scoop times: When the player win BONUS, the machine will automatically scoop the prizes into the disk.

Scoop times is 4, 4 scoops will scoop once. Scoop times is 8, 4 scoops will scoop twice.

Item	Value	SW2							
		1	2	3	4	5	6	7	8
BONUS Odds	3%	off	off						
	5%	on	off						
	10%	off	on						
	20%	on	on						
Wait Time (second) to Start Auto Play	Wait all the time			off	off				
	20			on	off				
	25			off	on				
	30			on	on				
						OFF	OFF	OFF	OFF

Item	Value	Controller							
		1	2	3	4	5	6	7	8
Stepping Motor	Setting	off	off	off	off	off	off	off	on

Input:				Extend Input:			
INPUT	Content	INPUT	Content	INPUT	Content	INPUT	Content
J1-1 (1)	1P Coin mechanism	J1-9 (9)	2P Coin mechanism	J7-1 (1)	3P Coin mechanism	J7-9 (9)	4P Coin mechanism
J1-2 (2)	1P Button	J1-10 (10)	2P Button	J7-2 (2)	3P Button	J7-10 (10)	4P Button
J1-3 (3)		J1-11 (11)		J7-3 (3)		J7-11 (11)	
J1-4 (4)		J1-12 (12)		J7-4 (4)		J7-12 (12)	
J1-5 (5)	1P Reset button	J1-13 (13)	2P Reset button	J7-5 (5)	3P Reset button	J7-13 (13)	4P Reset button
J1-6 (6)	1P Service button	J1-14 (14)	2P Service button	J7-6 (6)	3P Service button	J7-14 (14)	4P Service button
J1-7 (7)	Tilt alarm R	J1-15 (15)		J7-7 (7)		J7-15 (15)	
J1-8 (8)		J1-16 (16)		J7-8 (8)		J7-16 (16)	

Output:					
OUTPUT	Content	OUTPUT	Content	OUTPUT	Content
J2-1 (1)		J3-9 (9)	1P Coin mechanism GND	J7-1 (17)	1P Coin counter
J2-2 (2)		J3-10 (10)	2P Coin mechanism GND	J7-2 (18)	2P Coin counter
J2-3 (3)		J3-11 (11)	3P Coin mechanism GND	J7-3 (19)	3P Coin counter
J2-4 (4)		J3-12 (12)	4P Coin mechanism GND	J7-4 (20)	4P Coin counter
J2-5 (5)		J3-13 (13)		J7-5 (21)	1P Button light
J2-6 (6)		J3-14 (14)		J7-6 (22)	2P Button light
J2-7 (7)		J3-15 (15)		J7-7 (23)	3P Button light
J2-8 (8)		J3-16 (16)		J7-8 (24)	4P Button light

Input:				Extend Input:			
INPUT	Content	INPUT	Content	INPUT	Content	INPUT	Content
J1-1 (1)	1P Claw depth SW	J1-9 (9)	3P Claw depth SW	J1-1 (1)	Turntable zero sensor	J1-9 (9)	
J1-2 (2)	1P Scoop upper sensor	J1-10 (10)	3P Scoop upper sensor	J1-2 (2)		J1-10 (10)	
J1-3 (3)	1P Scoop lower sensor	J1-11 (11)	3P Scoop lower sensor	J1-3 (3)		J1-11 (11)	
J1-4 (4)	1P BONUS sensor	J1-12 (12)	3P BONUS sensor	J1-4 (4)		J1-12 (12)	
J1-5 (5)	2P Claw depth SW	J1-13 (13)	4P Claw depth SW	J1-5 (5)		J1-13 (13)	
J1-6 (6)	2P Scoop upper sensor	J1-14 (14)	4P Scoop upper sensor	J1-6 (6)		J1-14 (14)	
J1-7 (7)	2P Scoop lower sensor	J1-15 (15)	4P Scoop lower sensor	J1-7 (7)		J1-15 (15)	
J1-8 (8)	2P BONUS sensor	J1-16 (16)	4P BONUS sensor	J1-8 (8)		J1-16 (16)	

Output:				Extend Output:			
OUTPUT	Content	OUTPUT	Content	OUTPUT	Content	OUTPUT	Content
J2-1 (1)	1P Lift motor A	J3-1 (9)	3P Lift motor A	J1-1 (1)	Pusher Motor A	J1-1 (1)	2P Light
J2-2 (2)	1P Lift motor B	J3-2 (10)	3P Lift motor B	J1-2 (2)	Pusher Motor B	J1-2 (2)	3P Light
J2-3 (3)	1P Scoop motor A	J3-3 (11)	3P Scoop motor A	J1-3 (3)	1# Scoop light	J1-3 (3)	4P Light
J2-4 (4)	1P Scoop motor B	J3-4 (12)	3P Scoop motor B	J1-4 (4)	2# Scoop light	J1-4 (4)	
J2-5 (5)	2P Lift motor A	J3-5 (13)	4P Lift motor A	J1-5 (5)	3# Scoop light	J1-5 (5)	
J2-6 (6)	2P Lift motor B	J3-6 (14)	4P Lift motor B	J1-6 (6)	4# Scoop light	J1-6 (6)	
J2-7 (7)	2P Scoop motor A	J3-7 (15)	4P Scoop motor A	J1-7 (7)	Stepping motor EN	J1-7 (7)	
J2-8 (8)	2P Scoop motor B	J3-8 (16)	4P Scoop motor B	J1-8 (8)	1P Light	J1-8 (8)	

Separate port J5:	(Main board 1)
PROT	Content
5V	
12V	
GND	
P10	
P11	
P12	RXD
P13	TXD

Separate port J6:	(Main board 1)
PROT	Content
5V	
12V	
GND	
P14	Display SCK
P15	Display RCK
P16	Display SI
P17	

Separate port	(Main board 2)
PROT	Content
5V	
12V	
GND	
P10	Light ring SCK
P11	Light ring RCK
P12	Light ring SI
P13	Stepping motor CP

LED display:	Time
LED:	1,2,3 bit X4
Memory clear:	Press "TEST" and "SERVICE" button to restart the machine to clear memory.

<b>Error code:</b>
<b>E01 Scoop upper sensor error</b>
<b>E02 Scoop lower sensor error</b>
<b>E03 Ticket roll height SW error</b>
<b>E04 Tilt alarm</b>
<b>E07 Stepping motor zero sensor</b>
<b>E08 Communication error</b>

Note: Please reset the machine to Normal mode after removing the packing. (Refer to Instruction of Resetting The Machine to Normal Mode)

## 6.2 Ticket Dome RFID I/O Chart

Input: J20							
INPUT	Content	INPUT	Content	INPUT	Content	INPUT	Content
IN1		IN9	1#Gate motor initial	IN17	Switch DIP1	J25-T1_IN	1#Ticket feedback
IN2		IN10	2#Gate motor initial	IN18	Switch DIP2	J25-T2_IN	2#Ticket feedback
IN3		IN11	3#Gate motor initial	IN19	Switch DIP3		
IN4		IN12	4#Gate motor initial	IN20	Switch DIP4		
IN5	1#Ticket reset	IN13		IN21	Switch DIP5		
IN6	2#Ticket reset	IN14		IN22	Switch DIP6		
IN7	3#Ticket reset	IN15	3#Ticket feedback	IN23	Switch DIP7		
IN8	4#Ticket reset	IN16	4#Ticket feedback	IN24	Switch DIP8		

Output: J21		J22		J23		J25	
OUTPUT	Content	OUTPUT	Content	OUTPUT	Content	OUTPUT	Content
OUT1	1#Gate motor A	OUT9	1#Ticket meter	OUT17			
OUT2	2#Gate motor A	OUT10	2#Ticket meter	OUT18		J25-T2_OUT	2#Ticket drive
OUT3	3#Gate motor A	OUT11	3#Ticket meter	OUT19	3#Ticket drive	J25-T1_OUT	1#Ticket drive
OUT4	4#Gate motor A	OUT12	4#Ticket meter	OUT20	4#Ticket drive		
OUT5	1#Pusher Motor	OUT13	1#Gate motor B	OUT21	1#Out of ticket light		
OUT6	2#Pusher Motor	OUT14	2#Gate motor B	OUT22	2#Out of ticket light		
OUT7	3#Pusher Motor	OUT15	3#Gate motor B	OUT23	3#Out of ticket light		
OUT8	4#Pusher Motor	OUT16	4#Gate motor B	OUT24	4#Out of ticket light		

Switch Setting: DIP1

Content	Parameters	DIP1	DIP2	DIP3	DIP4	DIP5	DIP6	DIP7	DIP8
1P Power consumption	1 Minimum			off	off	off			
	2			on	off	off			
	3			off	on	off			
	4			on	on	off			
	5			off	off	on			
	6			on	off	on			
	7			off	on	on			
	8 Maximum			on	on	on			
2P Power consumption	1 Minimum						off	off	off
	2						on	off	off
	3						off	on	off
	4						on	on	off
	5						off	off	on
	6						on	off	on
	7						off	on	on
	8 Maximum						on	on	on
BONUS Prize	1 Ticket roll	OFF	OFF						
	2 Ticket roll	on	off						
	3 Ticket roll	off	on						
	4 Ticket roll	on	on						

Switch Setting: DIP2

Content	Parameters	DIP1	DIP2	DIP3	DIP4	DIP5	DIP6	DIP7	DIP8
3P Power consumption	1 Minimum			off	off	off			
	2			on	off	off			
	3			off	on	off			
	4			on	on	off			
	5			off	off	on			
	6			on	off	on			
	7			off	on	on			
	8 Maximum			on	on	on			

Content	Parameters	DIP1	DIP2	DIP3	DIP4	DIP5	DIP6	DIP7	DIP8
4P Power consumption	1 Minimum						off	off	off
	2						on	off	off
	3						off	on	off
	4						on	on	off
	5						off	off	on
	6						on	off	on
	7						off	on	on
	8 Maximum						on	on	on
Ticket	No ticket	off							
	Ticket	ON							

Communication:

Item	Content
COM1	To card reader
USB	

ADC PART:

Item	Content	Content
(A/D)0 (J3)		
(A/D)1 (J4)		
(A/D)2 (J5)		
(A/D)3 (J6)		
(A/D)4 (J7)		

Separate port:

Item	Content	Content
IIC(J14)	5V	
	SDA	RXD
	SCL	TXD
	GND	GND
PWM1-6 (J15)	GND	
	PWM1	
	PWM2	
	PWM3	
	PWM4	
	PWM5	
	PWM6	
SPI(J16)	12V	
	5V	
	MOSI	
	MISO	
	SCK	
	NSS	
	GND	



Item	Content	Content
(A/D)5 (J8)		
(A/D)6 (J9)		
(A/D)7 (J10)		

## 7. TROUBLESHOOTING

### 7.1 Common Problem

Please confirm whether every connector connected tightly.

Symptom	Possible Cause	Recommended action
Game will not start	Frame assembly connector is loose.	Plug the connector tightly.
	Frame assembly fault	Contact with UNIS Service.
Power cutting	Circuit protector make power SW in cutting state	Turn on power SW again. If appeared again and again, machine has anomaly. Please contact with UNIS Service.
Game will not coin up	Coin mechanism fault or sample coin not installed.	Change coin mechanism or sample coin.
	Coin mechanism signal cable loose.	Check coin mechanism signal cable loose.
	IO control board no signal.	Change IO board.
No sound	Volume set too low.	Raise the volume.
	Connector loose.	Plug in connector tightly.
	PCB fault.	Change PCB.
	Speaker fault.	Change speaker.
	POT installation error.	Install POT correctly.
	POT fault.	Change POT.
	Audio cable problem.	Reconnect the audio cable or change it.
Driver problem	Restart the audio driver.	

## 8. MAINTENANCE & INSPECTION

### 8.1 Safety Check

Check the points listed before operating the machine. These checks are necessary for safe machine operation:

1. Test game before operation each day.
2. Conduct monthly routine checks of game components ensure good working condition
3. Check the machine regularly for dust and clean when necessary.

**Note:** Parts and components require preventative maintenance to maintain proper operation.

### 8.2 Handling Precautions

When installing or inspecting the machine, be very careful of the following points and pay attention to ensure that the player can enjoy the game safely.

Non-compliance with the following points or inappropriate handling running counter to the cautionary matters herein stated can cause personal injury or damage to the machine



### NOTICE

We do not recommend using power tools as they may cause damage.

## 9. OVERALL CONSTRUCTION

### 9.1 Electrical Components

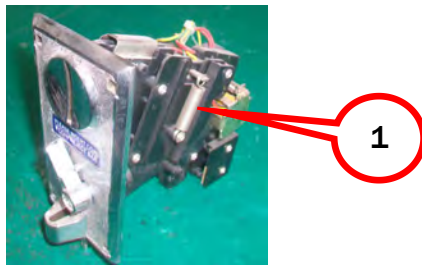

No.	Part No.	Drawing No.	Name	Qty
1	T151-410-000	PQXS.DQ-10	Coin mechanism	4



No.	Part No.	Drawing No.	Name	Qty
1	T151-439-000	PQXS.DQ-39	Speaker	2

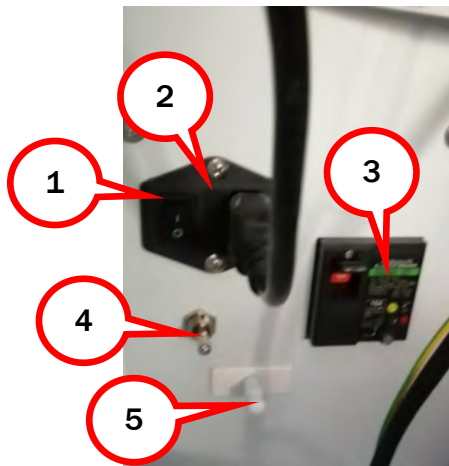

No.	Part No.	Drawing No.	Name	Qty
1	T151-444-000	PQXS.DQ-44	Filter	1
2	T151-445-000	PQXS.DQ-45	Fuse	1
3	T151-443-000	PQXS.DQ-43	Residual current circuit breaker	1
4	T151-428-000	PQXS.DQ-28	Toggle switch	1
5	T151-442-000	PQXS.DQ-42	Shut-off switch	1

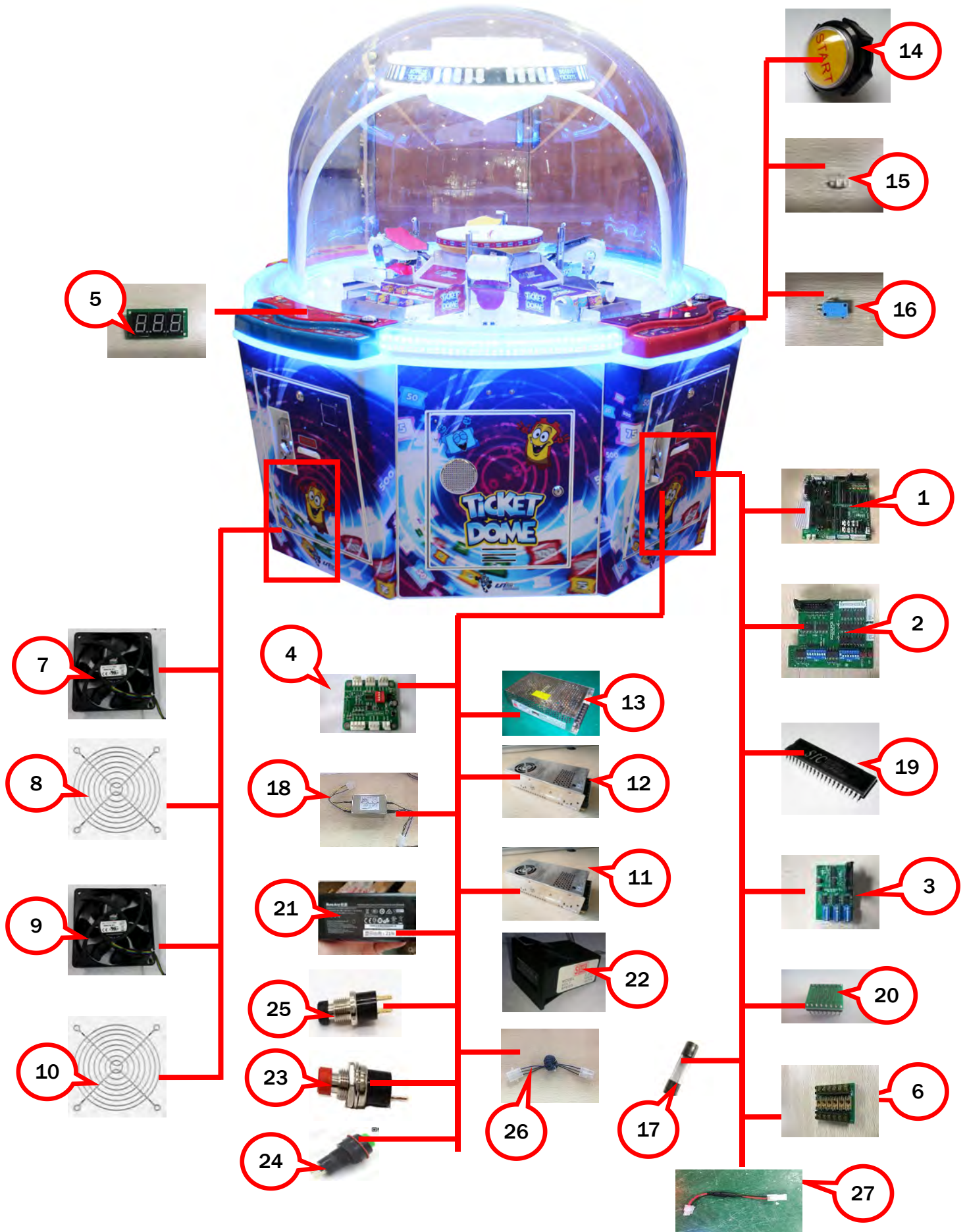

No	Part No.	Drawing No.	Name	Qty
1	T151-401-000	PQXS.DQ-01	Main board	2
2	T151-402-000	PQXS.DQ-02	Extension board	1
3	T151-403-000	PQXS.DQ-03	PCB board	1
4	T151-405-000	PQXS.DQ-05	Light control board	1
5	T151-408-000	PQXS.DQ-08	Display	8
6	T151-409-000	PQXS.DQ-09	Fuse board	1
7	T151-429-000	PQXS.DQ-29	Fan	1
8	T151-430-000	PQXS.DQ-30	Fan net	2
9	T151-431-000	PQXS.DQ-31	Fan	2
10	T151-432-000	PQXS.DQ-32	Fan net	4
11	T151-433-000	PQXS.DQ-33	Power supply(24V)	1
12	T151-434-000	PQXS.DQ-34	Power supply(12V)	1
13	T151-435-000	PQXS.DQ-35	Power supply(5V)	1
14	T151-436-000	PQXS.DQ-36	Button	4
15	T151-437-000	PQXS.DQ-37	LED light	4
16	T151-438-000	PQXS.DQ-38	Button switch	4
17	T151-446-000	PQXS.DQ-46	Fuse	8
18	T151-440-000	PQXS.DQ-40	Filter	1
19	T151-453-000	PQXS.DQ-53	Single chip microcomputer	2
20	T151-454-000	PQXS.DQ-54	Music chip	1
21	T151-455-000	PQXS.DQ-55	Adapter	1
22	T151-448-000	PQXS.DQ-48	Counter	8
23	T151-449-000	PQXS.DQ-49	Red button	4
24	T151-450-000	PQXS.DQ-50	Green button	4
25	T151-451-000	PQXS.DQ-51	Black button	4
26	T151-441-000	PQXS.DQ-41	Mn-Zinc green ring	1
27	T151-447-000	PQXS.DQ-47	Fuse holder	8

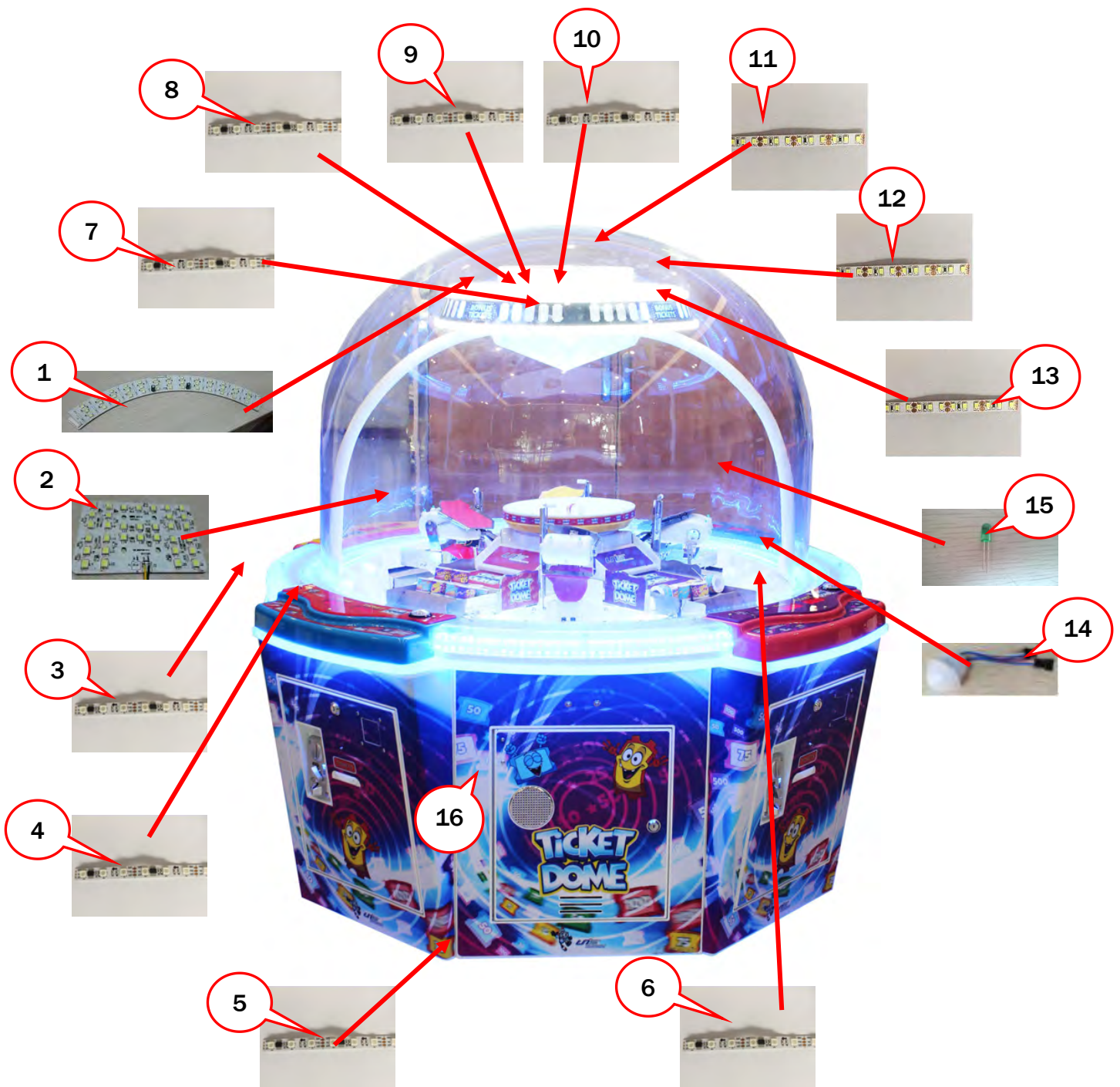

No.	Part No.	Drawing No.	Name	QTY
1	T151-407-000	PQXS.DQ-07	Light board	4
2	T151-406-000	PQXS.DQ-06	LED PCB board	4
3	T151-411-000	PQXS.DQ-11	Inside breath light	1
4	T151-412-000	PQXS.DQ-12	Outside breath light	1
5	T151-413-000	PQXS.DQ-13	Bottom breath light	1
6	T151-414-000	PQXS.DQ-14	Outside line breath light	8
7	T151-415-000	PQXS.DQ-15	Marquee breath light	1
8	T151-416-000	PQXS.DQ-16	Marquee light 1	2
9	T151-417-000	PQXS.DQ-17	Marquee light 2	2
10	T151-418-000	PQXS.DQ-18	Marquee light 3	2
11	T151-419-000	PQXS.DQ-19	Marquee inside light	1
12	T151-420-000	PQXS.DQ-20	Marquee upper white light	1
13	T151-421-000	PQXS.DQ-21	Marquee bottom white light	1
14	T151-422-000	PQXS.DQ-22	Scoop light	12
15	T151-423-000	PQXS.DQ-23	Light bulb	8
16	T151-459-000	23100000005	Ticket dispenser	4
	T151-460-000	29790700002	Ticket converted board	4

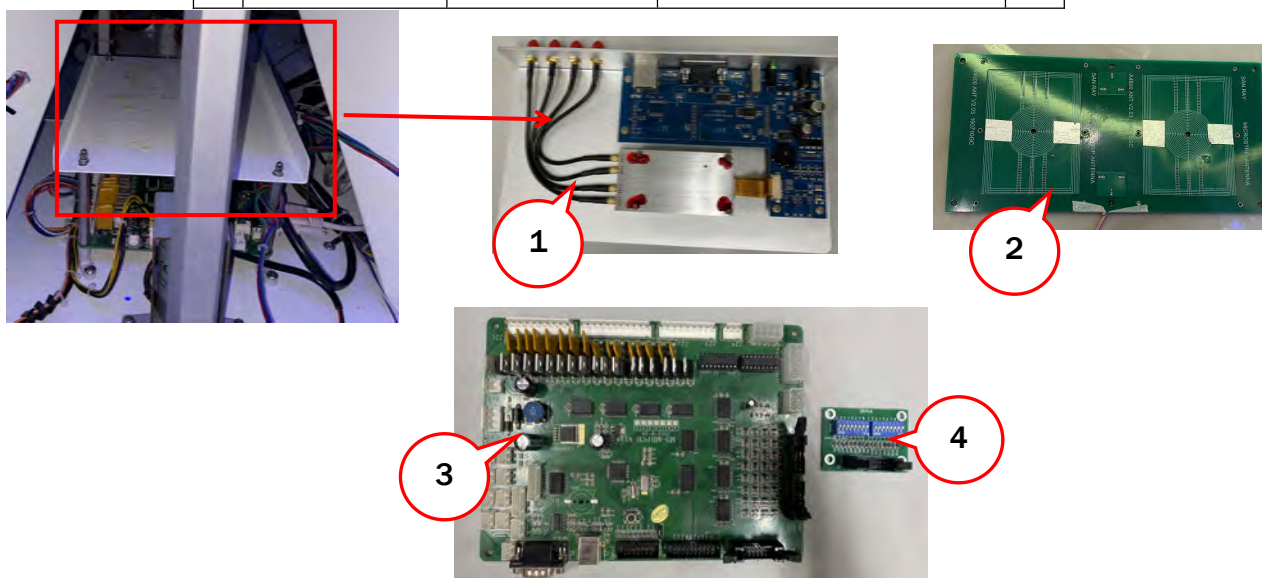

No.	Part No.	Drawing No.	Name	QTY
1	T151-457-000	20221901Y006	RFID reader	1
2	T151-458-000	20221901Y007	RFID antenna	4
3	T151-461-000	29791300001	M3 main board	1
4	T151-462-000	20221901Y016	RFID switch board	1

## 9.2 Decals







No.	Part No.	Drawing No.	Name	QTY
1	T151-707-000	PQXS.HM-01	Speaker door decal	2
2	T151-708-000	PQXS.HM-02	Service door decal	2
3	T151-709-000	PQXS.HM-03	Coin mechanism door decal	4
4	T151-710-000	PQXS.HM-04	Red player decal	1
	T151-711-000	PQXS.HM-05	Yellow player decal	1
	T151-712-000	PQXS.HM-06	Blue player decal	1
	T151-713-000	PQXS.HM-07	Purple player decal	1
5	T151-738-000	PQXS.HM-32	Blue decal	1
	T151-739-000	PQXS.HM-33	Purple decal	1
	T151-740-000	PQXS.HM-34	Red decal	1
	T151-741-000	PQXS.HM-35	Yellow decal	1
6	T151-718-000	PQXS.HM-12	Pusher blue decal	1
	T151-719-000	PQXS.HM-13	Pusher purple decal	1
	T151-720-000	PQXS.HM-14	Pusher red decal	1
	T151-721-000	PQXS.HM-15	Pusher yellow decal	1
7	T151-722-000	PQXS.HM-16	Ticket check panel blue decal	1
	T151-723-000	PQXS.HM-17	Ticket check panel purple decal	1
	T151-724-000	PQXS.HM-18	Ticket check panel red decal	1
	T151-725-000	PQXS.HM-19	Ticket check panel yellow decal	1
8	T151-726-000	PQXS.HM-20	Play instruction blue decal	1
	T151-727-000	PQXS.HM-21	Play instruction purple decal	1
	T151-728-000	PQXS.HM-22	Play instruction red decal	1
	T151-729-000	PQXS.HM-23	Play instruction yellow decal	1

No.	Part No.	Drawing No.	Name	QTY
9	T151-730-000	PQXS.HM-24	Pusher side blue decal	1
	T151-731-000	PQXS.HM-25	Pusher side purple decal	1
	T151-732-000	PQXS.HM-26	Pusher side red decal	1
	T151-733-000	PQXS.HM-27	Pusher side yellow decal	1
10	T151-734-000	PQXS.HM-28	Blue LOGO decal	1
	T151-735-000	PQXS.HM-29	Purple LOGO decal	1
	T151-736-000	PQXS.HM-30	Red LOGO decal	1
	T151-737-000	PQXS.HM-31	Yellow LOGO decal	1
11	T151-742-000	PQXS.HM-36	BOUNS decal	1
12	T151-743-000	PQXS.HM-37	Button decal	1

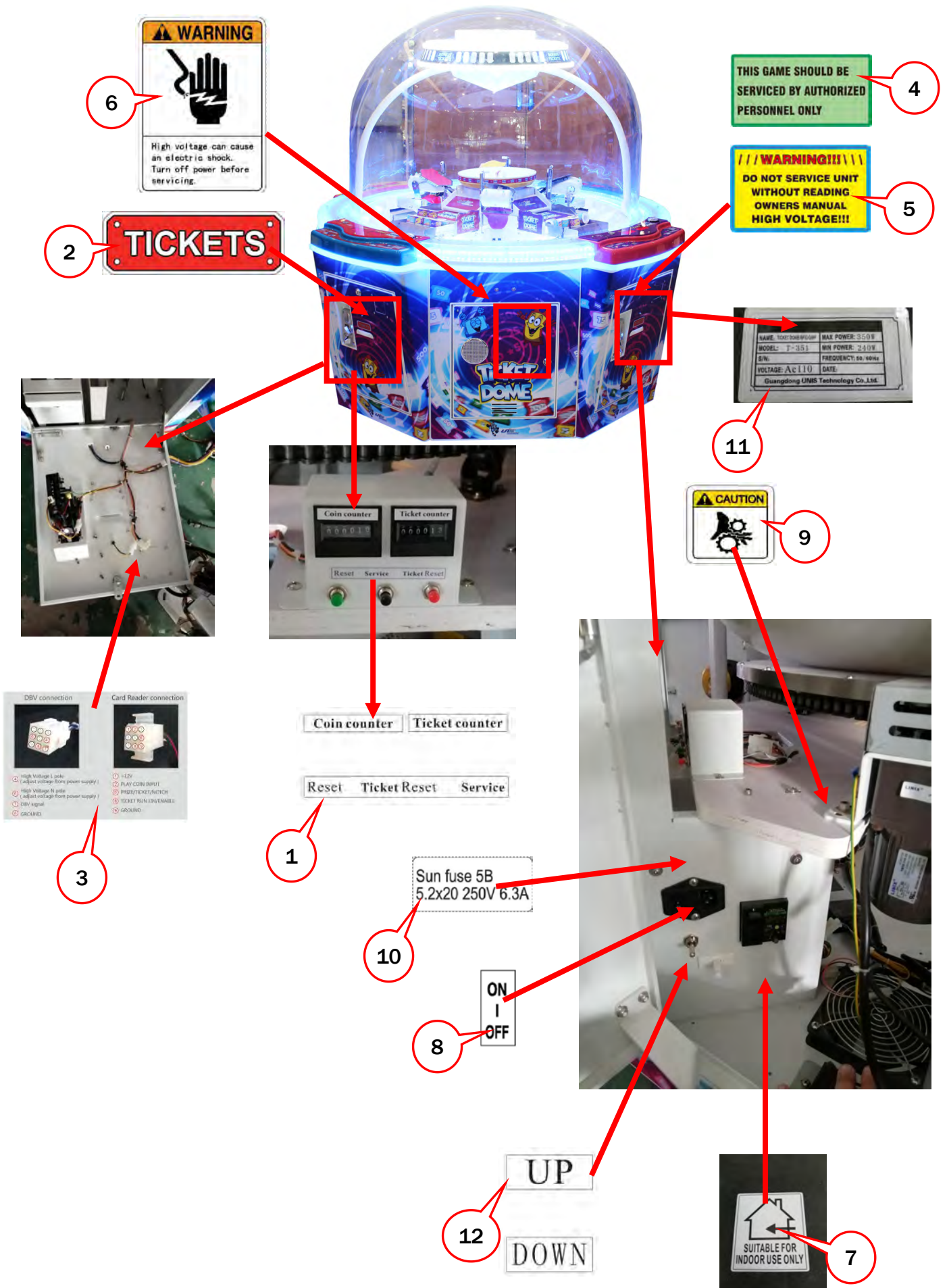

No.	Part No.	Drawing No.	Name	QTY
1	T151-744-000	PQXS.HM-38	Counter decal	4
2	T151-745-000	PQXS.HM-39	Ticket decal	4
3	T151-746-000	PQXS.HM-40	DBV port decal	4
4	T151-747-000	PQXS.HM-41	Service label(green)	2
5	T151-748-000	PQXS.HM-42	High voltage warning decal	1
6	T151-749-000	PQXS.HM-43	High voltage label	2
7	T151-750-000	PQXS.HM-44	Inside label	1
8	T151-751-000	PQXS.HM-45	Switch decal	1
9	T151-752-000	PQXS.HM-46	Caution label	5
10	T151-753-000	PQXS.HM-47	Fuse label	1
11	T151-754-000	PQXS.HM-48	Nameplate label	1
12	T151-755-000	PQXS.HM-49	Up-down decal	1

[www.universal-space.com](http://www.universal-space.com)

# 10. WIRING DIAGRAM

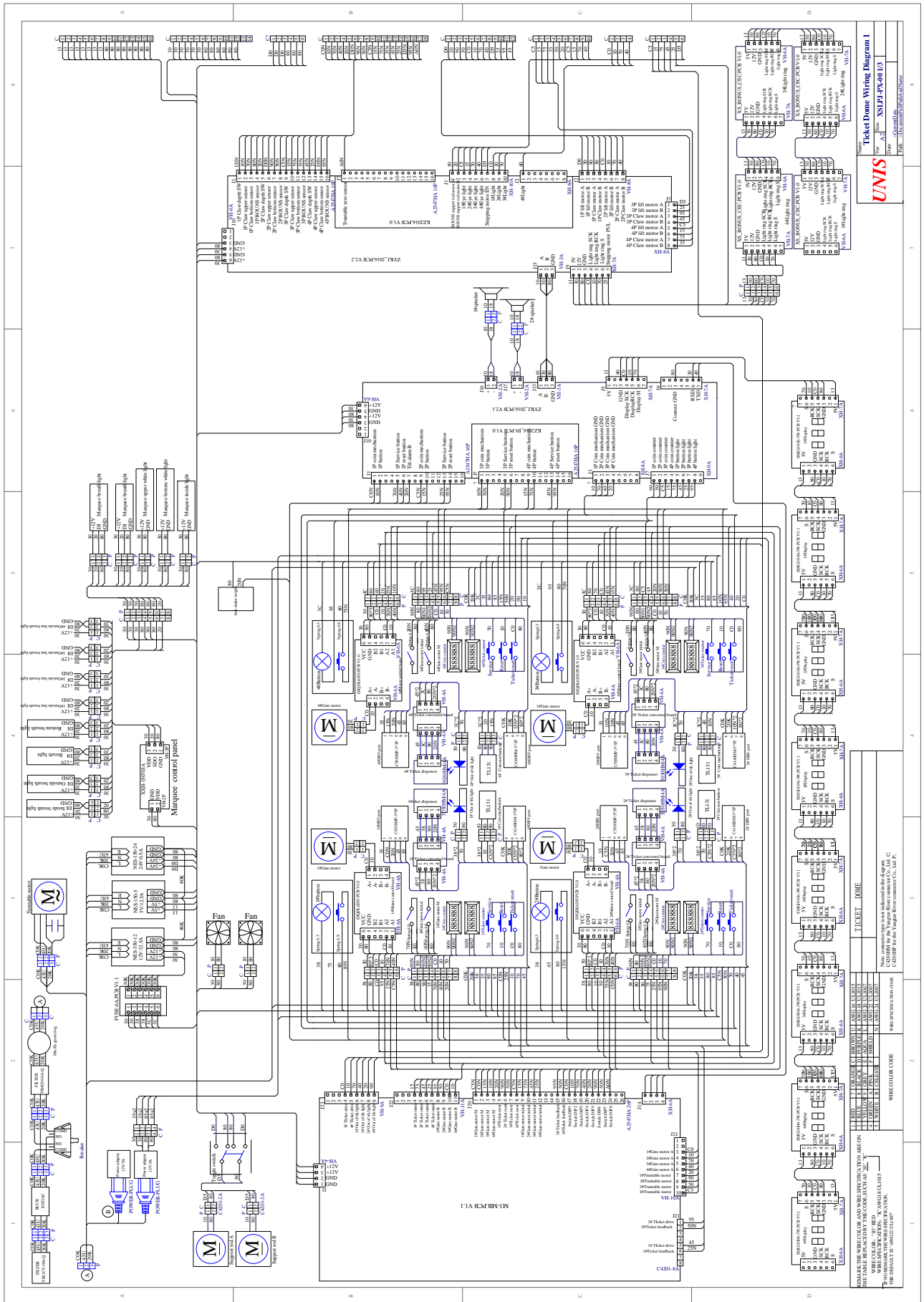

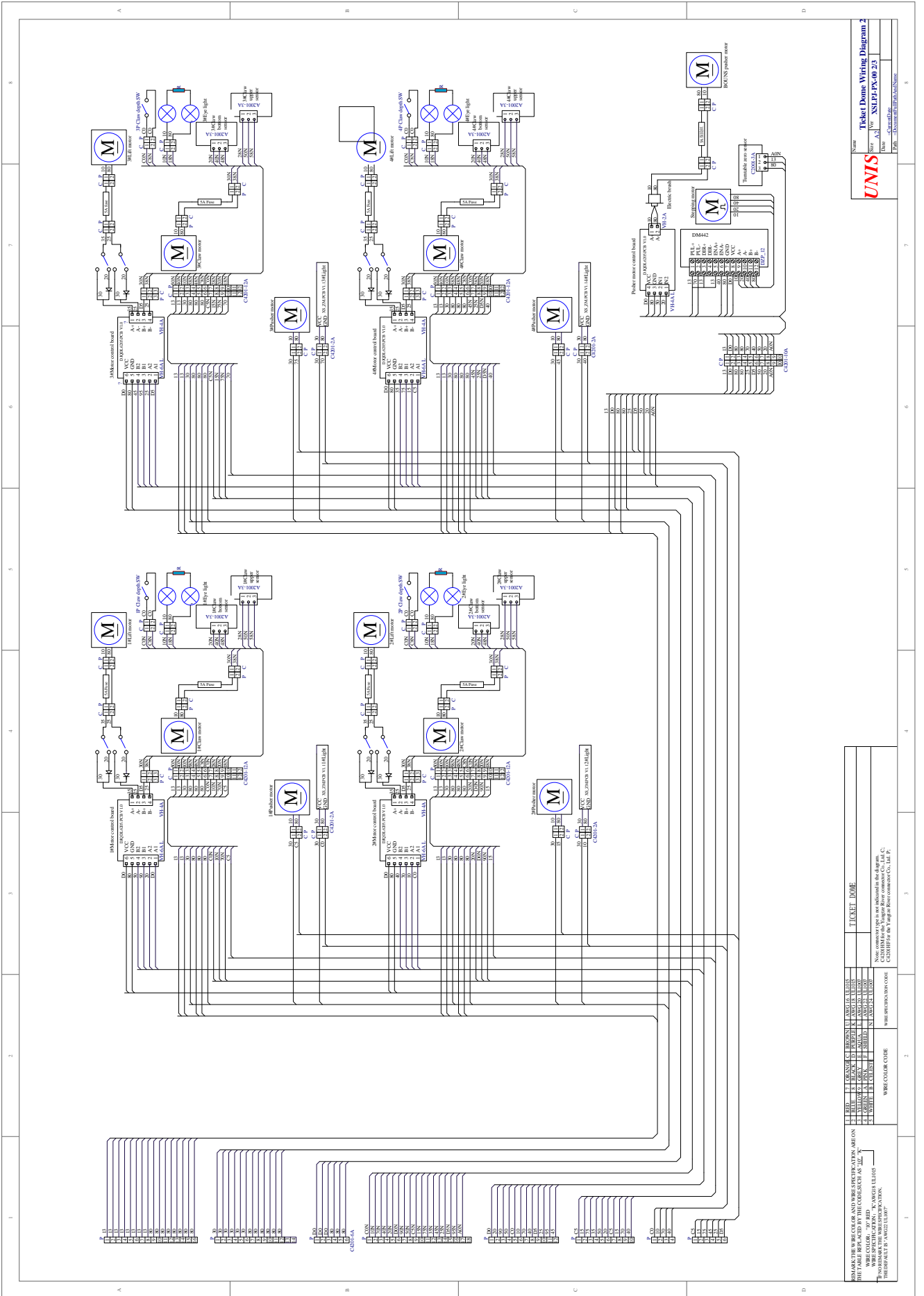

UNIS  
 Name: \_\_\_\_\_  
 Date: \_\_\_\_\_  
 Page: \_\_\_\_\_  
 Title: Treasure Dome Wiring Diagram 2

WIRE COLOR	WIRE COLOR CODE	WIRE COLOR CODE	TICKET #	DATE
RED	1	1		
BROWN	2	2		
ORANGE	3	3		
YELLOW	4	4		
GREEN	5	5		
BLUE	6	6		
PURPLE	7	7		
PINK	8	8		
WHITE	9	9		
BLACK	10	10		
GRAY	11	11		
SILVER	12	12		
GOLD	13	13		
PLATINUM	14	14		
DIAMOND	15	15		
EMERALD	16	16		
SAPPHIRE	17	17		
TOPAZ	18	18		
ONYX	19	19		
JAGGED	20	20		
SMOOTH	21	21		
ROUGH	22	22		
SHINY	23	23		
OPAKE	24	24		
TRANSPARENT	25	25		
OPAQUE	26	26		
GLASS	27	27		
PLASTIC	28	28		
METAL	29	29		
WOOD	30	30		
STONE	31	31		
LEATHER	32	32		
PAPER	33	33		
FABRIC	34	34		
HAIR	35	35		
SKIN	36	36		
BLOOD	37	37		
TEARS	38	38		
SWEAT	39	39		
SPIT	40	40		
URINE	41	41		
FEWES	42	42		
POO	43	43		
SMOKE	44	44		
ASH	45	45		
SOOT	46	46		
DUST	47	47		
MUD	48	48		
SLIME	49	49		
GLUE	50	50		
WAX	51	51		
RESIN	52	52		
ROCK	53	53		
CLAY	54	54		
GLASS	55	55		
PLASTIC	56	56		
METAL	57	57		
WOOD	58	58		
STONE	59	59		
LEATHER	60	60		
PAPER	61	61		
FABRIC	62	62		
HAIR	63	63		
SKIN	64	64		
BLOOD	65	65		
TEARS	66	66		
SWEAT	67	67		
SPIT	68	68		
URINE	69	69		
FEWES	70	70		
POO	71	71		
SMOKE	72	72		
ASH	73	73		
SOOT	74	74		
DUST	75	75		
MUD	76	76		
SLIME	77	77		
GLUE	78	78		
WAX	79	79		
RESIN	80	80		

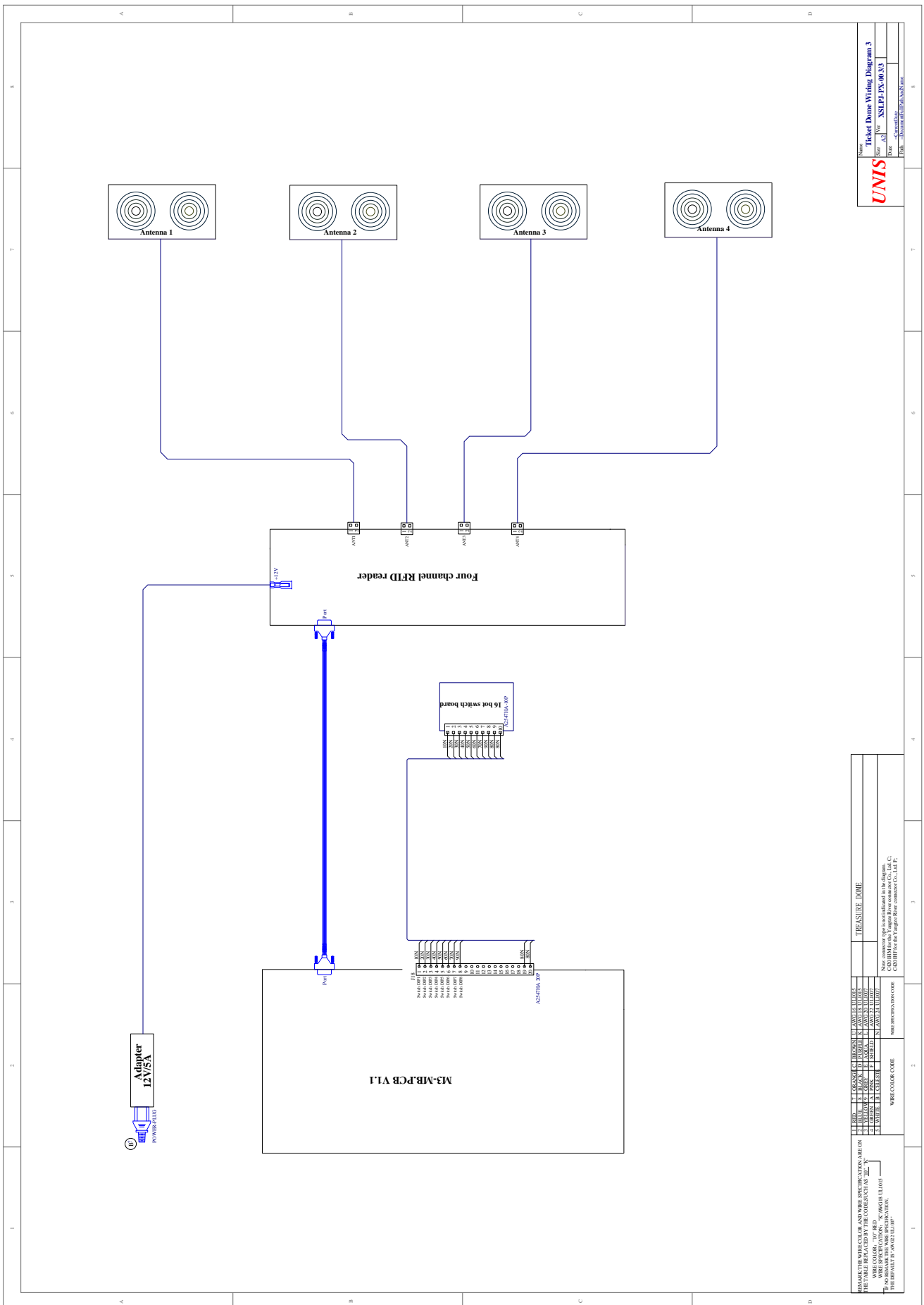



### **FCC Statement**

This device complies with part 15 of the FCC Rules. Operation is subject to the following two conditions:

(1) This device may not cause harmful interference, and (2) this device must accept any interference received, including interference that may cause undesired operation. Any Changes or modifications not expressly approved by the party responsible for compliance could void the user's authority to operate the equipment.

Note: This equipment has been tested and found to comply with the limits for a Class B digital device, pursuant to part 15 of the FCC Rules. These limits are designed to provide reasonable protection against harmful interference in a residential installation. This equipment generates uses and can radiate radio frequency energy and, if not installed and used in accordance with the instructions, may cause harmful interference to radio communications. However, there is no guarantee that interference will not occur in a particular installation. If this equipment does cause harmful interference to radio or television reception, equipment generates, uses and can radiate radio frequency energy and, if not installed and used in accordance with the instructions, may cause harmful interference to radio communications. However, there is no guarantee that interference will not occur in a particular installation. If this equipment does cause harmful interference to radio or television reception,

- Reorient or relocate the receiving antenna.
- Increase the separation between the equipment and receiver.
- Connect the equipment into an outlet on a circuit different from that to which the receiver is connected.
- Consult the dealer or an experienced radio/TV technician for help.