

MEASUREMENT REPORT

FCC PART 15C WLAN 802.11b/g/n

FCC ID: 2AQJT-U1

APPLICANT: Actions Microelectronics Co., Ltd.

Application Type: Certification

Product: EZCast Ultra Wireless Display Receiver

Model No.: EZCast Ultra U1

Serial Model No.: EZCast Ultra U2, MagicUltra U1, MagicUltra U2

Brand Name: EZCast Ultra, Magic Ultra

FCC Classification: Digital Transmission System (DTS)

FCC Rule Part(s): Part 15 Subpart C (Section 15.247)

Test Procedure(s): ANSI C63.10-2013, KDB 558074 D01v05r02

Test Date: November 09 ~ December 10, 2019

Reviewed By:

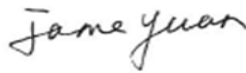

(Jame Yuan)

Approved By:

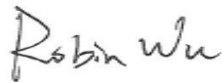

(Robin Wu)



The test results relate only to the samples tested.

This equipment has been shown to be capable of compliance with the applicable technical standards as indicated in the measurement report and was tested in accordance with the measurement procedures specified in ANSI C63.10-2013. Test results reported herein relate only to the item(s) tested.

The test report shall not be reproduced except in full without the written approval of MRT Technology (Suzhou) Co., Ltd.

Revision History

Report No.	Version	Description	Issue Date	Note
1911RSU009-U2	Rev. 01	Initial Report	12-23-2019	Valid

CONTENTS

Description	Page
1. INTRODUCTION.....	6
1.1. Scope.....	6
1.2. MRT Test Location.....	6
2. PRODUCT INFORMATION.....	7
2.1. Equipment Description.....	7
2.2. Product Specification Subjective to this Report.....	7
2.3. Working Frequencies for this report.....	8
2.4. Test Mode.....	8
2.5. Description of Test Software.....	9
2.6. Device Capabilities.....	10
2.7. Test Configuration.....	11
2.8. EMI Suppression Device(s)/Modifications.....	11
2.9. Labeling Requirements.....	11
3. DESCRIPTION of TEST.....	12
3.1. Evaluation Procedure.....	12
3.2. AC Line Conducted Emissions.....	12
3.3. Radiated Emissions.....	13
4. ANTENNA REQUIREMENTS.....	14
5. TEST EQUIPMENT CALIBRATION DATE.....	15
6. MEASUREMENT UNCERTAINTY.....	17
7. TEST RESULT.....	18
7.1. Summary.....	18
7.2. 6dB Bandwidth Measurement.....	19
7.2.1. Test Limit.....	19
7.2.2. Test Procedure used.....	19
7.2.3. Test Setting.....	19
7.2.4. Test Setup.....	19
7.2.5. Test Result.....	20
7.3. Output Power Measurement.....	25
7.3.1. Test Limit.....	25
7.3.2. Test Procedure Used.....	25
7.3.3. Test Setting.....	25
7.3.4. Test Setup.....	26

7.3.5.	Test Result of Output Power	27
7.4.	Power Spectral Density Measurement.....	29
7.4.1.	Test Limit	29
7.4.2.	Test Procedure Used	29
7.4.3.	Test Setting.....	29
7.4.4.	Test Setup	29
7.4.5.	Test Result.....	30
7.5.	Conducted Band Edge and Out-of-Band Emissions	35
7.5.1.	Test Limit	35
7.5.2.	Test Procedure Used	35
7.5.3.	Test Setting.....	35
7.5.4.	Test Setup	36
7.5.5.	Test Result.....	37
7.6.	Radiated Spurious Emission Measurement	46
7.6.1.	Test Limit	46
7.6.2.	Test Procedure Used	46
7.6.3.	Test Setting.....	46
7.6.4.	Test Setup	48
7.6.5.	Test Result.....	49
7.7.	Radiated Restricted Band Edge Measurement.....	63
7.7.1.	Test Limit	63
7.7.2.	Test Procedure Used	64
7.7.3.	Test Setting.....	64
7.7.4.	Test Setup	65
7.7.5.	Test Result.....	66
7.8.	AC Conducted Emissions Measurement	114
7.8.1.	Test Limit	114
7.8.2.	Test Setup	114
7.8.3.	Test Result.....	115
8.	CONCLUSION	117
	Appendix A - Test Setup Photograph	118
	Appendix B - EUT Photograph.....	119

General Information

Applicant:	Actions Microelectronics Co., Ltd.
Applicant Address:	201, No.9 Building, Software Park, KeJiZhong Er Road, GaoXinQu, NanShan, Shenzhen, China
Manufacturer:	Actions Microelectronics Co., Ltd.
Manufacturer Address:	201, No.9 Building, Software Park, KeJiZhong Er Road, GaoXinQu, NanShan, Shenzhen, China
Test Site:	MRT Technology (Suzhou) Co., Ltd
Test Site Address:	D8 Building, No.2 Tian'edang Rd., Wuzhong Economic Development Zone, Suzhou, China
Test Device Serial No.:	N/A <input type="checkbox"/> Production <input checked="" type="checkbox"/> Pre-Production <input type="checkbox"/> Engineering

Test Facility / Accreditations

Measurements were performed at MRT Laboratory located in Tian'edang Rd., Suzhou, China.

- MRT facility is a FCC registered (MRT Reg. No. 893164) test facility with the site description report on file and has met all the requirements specified in ANSI C63.4-2014.
- MRT facility is an IC registered (MRT Reg. No. 11384A-1) test laboratory with the site description on file at Industry Canada.
- MRT facility is a VCCI registered (R-20025, G-20034, C-20020, T-20020) test laboratory with the site description on file at VCCI Council.
- MRT Lab is accredited to ISO 17025 by the American Association for Laboratory Accreditation (A2LA) under the American Association for Laboratory Accreditation Program (A2LA Cert. No. 3628.01) in EMC, Telecommunications, Radio and SAR testing.



1. INTRODUCTION

1.1. Scope

Measurement and determination of electromagnetic emissions (EMC) of radio frequency devices including intentional and/or unintentional radiators for compliance with the technical rules and regulations of the Federal Communications Commission and the Innovation, Science and Economic Development Canada and Certification and Engineering Bureau.

1.2. MRT Test Location

The map below shows the location of the MRT LABORATORY, its proximity to the Taihu Lake. These measurement tests were conducted at the MRT Technology (Suzhou) Co., Ltd. Facility located at D8 Building, No.2 Tian'edang Rd., Wuzhong Economic Development Zone, Suzhou, China. The measurement facility compliant with the test site requirements specified in ANSI C63.4-2014.



2. PRODUCT INFORMATION

2.1. Equipment Description

Product Name:	EZCast Ultra Wireless Display Receiver
Model No.:	EZCast Ultra U1
Serial Model No.:	EZCast Ultra U2, MagicUltra U1, MagicUltra U2
Brand Name:	EZCast Ultra, Magic Ultra
Wi-Fi Specification:	802.11a/b/g/n/ac
Bluetooth Version:	v5.0 single mode (Bluetooth-LE Only)
Power Supply:	5V==2A

Note 1: The different models and brands are only for marketing different clients, others are the same.

Note 2: The product does not come with adapter for marketing, and it's powered by adapter (model: FJ-SW266B50502000U) supplied by MRT for testing.

2.2. Product Specification Subjective to this Report

Frequency Range:	802.11b/g/n-HT20: 2412 ~ 2462MHz 802.11n-HT40: 2422 ~ 2452MHz
Channel Number:	802.11b/g/n-HT20: 11 802.11n-HT40: 7
Type of Modulation:	802.11b: DSSS 802.11g/n: OFDM
Data Rate:	802.11b: 1/2/5.5/11Mbps 802.11g: 6/9/12/18/24/36/48/54Mbps 802.11n: up to 150Mbps
Maximum Peak Output Power:	802.11b: 26.01dBm 802.11g: 26.55dBm 802.11n-HT20: 26.49dBm 802.11n-HT40: 26.47dBm
Antenna Type:	Shrapnel Antenna
Antenna Gain:	1.68dBi

Note: For other features of this EUT, test report will be issued separately.

2.3. Working Frequencies for this report

802.11b/g/n-HT20

Channel	Frequency	Channel	Frequency	Channel	Frequency
01	2412 MHz	02	2417 MHz	03	2422 MHz
04	2427 MHz	05	2432 MHz	06	2437 MHz
07	2442 MHz	08	2447 MHz	09	2452 MHz
10	2457 MHz	11	2462 MHz	--	--

802.11n-HT40

Channel	Frequency	Channel	Frequency	Channel	Frequency
03	2422 MHz	04	2427 MHz	05	2432 MHz
06	2437 MHz	07	2442 MHz	08	2447 MHz
09	2452 MHz	--	--	--	--

2.4. Test Mode

Test Mode	Mode 1: Transmit by 802.11b (1Mbps)
	Mode 2: Transmit by 802.11g (6Mbps)
	Mode 3: Transmit by 802.11n-HT20 (MCS0)
	Mode 4: Transmit by 802.11n-HT40 (MCS0)

2.5. Description of Test Software

The test utility software used during testing was “MPTool”, and the version was 0.0003.07.20190211.

Power Parameter Value

Test Mode	Test Channel No.	Test Frequency (MHz)	Power Parameter Value
802.11b	01	2412	55
	06	2437	54
	11	2462	53
802.11g	01	2412	53
	06	2437	55
	11	2462	54
802.11n-HT20	01	2412	51
	06	2437	55
	11	2462	53
802.11n-HT40	03	2422	47
	06	2437	55
	09	2452	49

2.6. Device Capabilities

This device contains the following capabilities:

2.4GHz WLAN (DTS) & 5GHz WLAN (UNII) & Bluetooth v5.0 single mode (DTS).

Note: 2.4GHz WLAN (DTS) operation is possible in 20MHz channel bandwidths. The maximum achievable duty cycles for all modes were determined based on measurements performed on a spectrum analyzer in zero-span mode with RBW = 8MHz, VBW = 50MHz. The RBW and VBW were both greater than 50/T, where T is the minimum transmission duration, and the number of sweep points across T was greater than 100. The duty cycles are as follows:

Test Mode	Duty Cycle
802.11b	100.00%
802.11g	100.00%
802.11n-HT20	100.00%
802.11n-HT40	100.00%

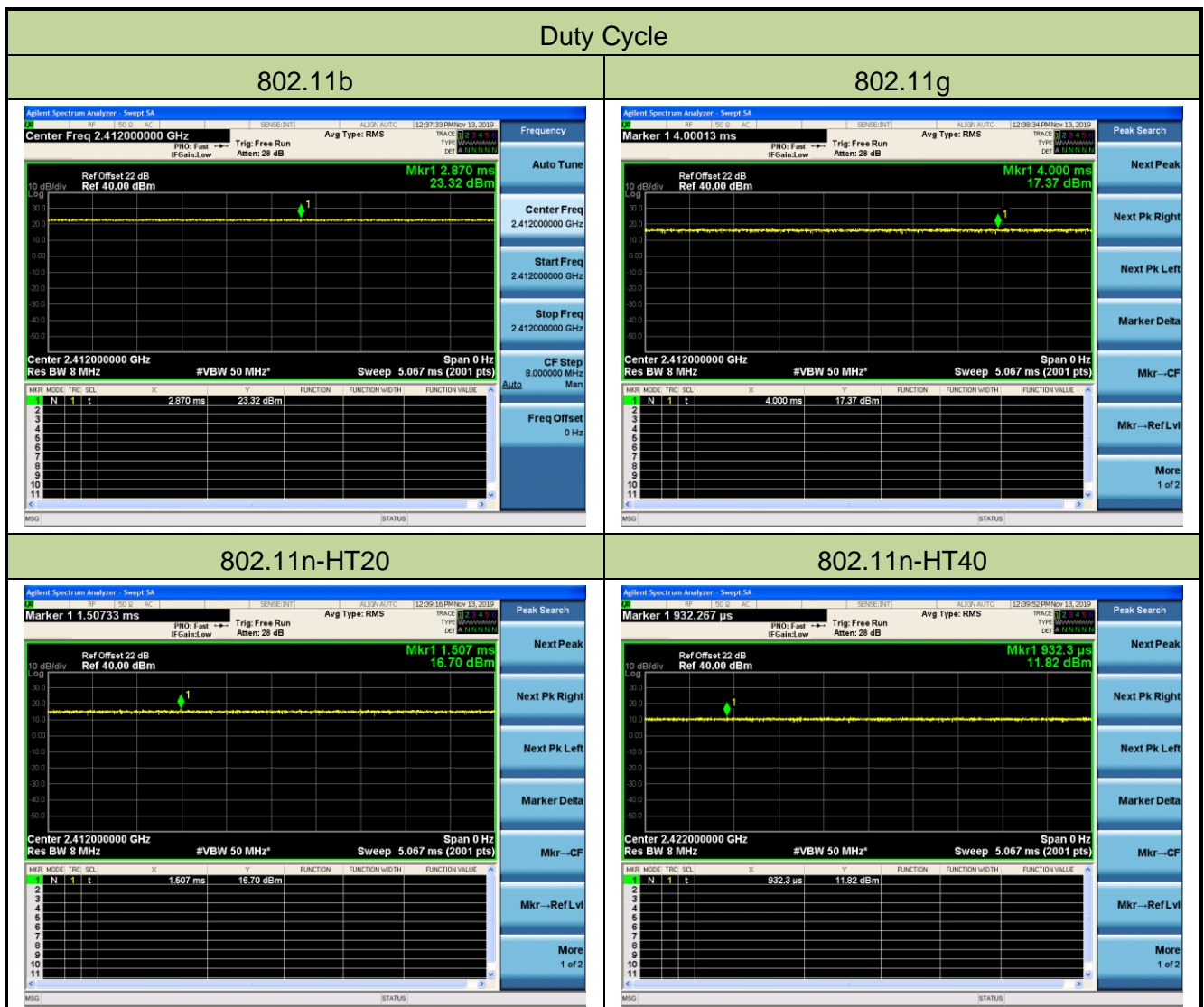

2.7. Test Configuration

The device was tested per the guidance of ANSI C63.10-2013. ANSI C63.10-2013 was used to reference the appropriate EUT setup for radiated spurious emissions testing and AC line conducted testing.

2.8. EMI Suppression Device(s)/Modifications

No EMI suppression device(s) were added and/or no modifications were made during testing.

2.9. Labeling Requirements

Per 2.1074 & 15.19; Docket 95-19

The label shall be permanently affixed at a conspicuous location on the device; instruction manual or pamphlet supplied to the user and be readily visible to the purchaser at the time of purchase. However, when the device is so small wherein placement of the label with specified statement is not practical, only the FCC ID must be displayed on the device per Section 15.19(a)(5). Please see attachment for FCC ID label and label location.

3. DESCRIPTION of TEST

3.1. Evaluation Procedure

The measurement procedures described in the American National Standard of Procedures for Compliance Testing of Unlicensed Wireless Devices (ANSI C63.10-2013), and the guidance provided in ANSI C63.10-2013 were used in the measurement.

Deviation from measurement procedure.....None

3.2. AC Line Conducted Emissions

The line-conducted facility is located inside an 8'x4'x4' shielded enclosure. A 1m x 2m wooden table 80cm high is placed 40cm away from the vertical wall and 80cm away from the sidewall of the shielded room. Two 10kHz-30MHz, 50Ω/50uH Line-Impedance Stabilization Networks (LISNs) are bonded to the shielded room floor. Power to the LISNs is filtered by external high-current high-insertion loss power line filters. These filters attenuate ambient signal noise from entering the measurement lines. These filters are also bonded to the shielded enclosure.

The EUT is powered from one LISN and the support equipment is powered from the second LISN. All interconnecting cables more than 1 meter were shortened to a 1 meter length by non-inductive bundling (serpentine fashion) and draped over the back edge of the test table. All cables were at least 40cm above the horizontal reference ground-plane. Power cables for support equipment were routed down to the second LISN while ensuring that that cables were not draped over the second LISN.

Sufficient time for the EUT, support equipment, and test equipment was allowed in order for them to warm up to their normal operating condition. The RF output of the LISN was connected to the receiver and exploratory measurements were made to determine the frequencies producing the maximum emission from the EUT. The receiver was scanned from 150kHz to 30MHz. The detector function was set to peak mode for exploratory measurements while the bandwidth of the analyzer was set to 9kHz. The EUT, support equipment, and interconnecting cables were arranged and manipulated to maximize each emission. Each emission was also maximized by varying: power lines, the mode of operation or data exchange speed, or support equipment which determined the worst-case emission. Once the worst case emissions have been identified, the one EUT cable configuration/arrangement and mode of operation that produced these emissions are used for final measurements on the same test site. The analyzer is set to CISPR quasi-peak and average detectors with a 9kHz resolution bandwidth for final measurements.

An extension cord was used to connect to a single LISN which powered by EUT. The extension cord was calibrated with LISN, the impedance and insertion loss are compliance with the requirements as stated in ANSI C63.10-2013.

3.3. Radiated Emissions

The radiated test facilities consisted of an indoor 3 meter semi-anechoic chamber used for final measurements and exploratory measurements, when necessary. The measurement area is contained within the semi-anechoic chamber which is shielded from any ambient interference. For measurements above 1GHz absorbers are arranged on the floor between the turn table and the antenna mast in such a way so as to maximize the reduction of reflections. For measurements below 1GHz, the absorbers are removed. A MF Model 210SS turntable is used for radiated measurement. It is a continuously rotatable, remote controlled, metallic turntable and 2 meters (6.56 ft.) in diameter. The turn table is flush with the raised floor of the chamber in order to maintain its function as a ground plane. An 80cm high PVC support structure is placed on top of the turntable.

For all measurements, the spectrum was scanned through all EUT azimuths and from 1 to 4 meter receive antenna height using a broadband antenna from 30MHz up to the upper frequency shown in 15.33(b)(1) depending on the highest frequency generated or used in the device or on which the device operates or tunes. For frequencies above 1GHz, linearly polarized double ridge horn antennas were used. For frequencies below 30MHz, a calibrated loop antenna was used. When exploratory measurements were necessary, they were performed at 1 meter test distance inside the semi-anechoic chamber using broadband antennas, broadband amplifiers, and spectrum analyzers to determine the frequencies and modes producing the maximum emissions. Sufficient time for the EUT, support equipment, and test equipment was allowed in order for them to warm up to their normal operating condition. The test set-up for frequencies below 1GHz was placed on top of the 0.8 meter high, 1 x 1.5 meter table; and test set-up for frequencies 1-40GHz was placed on top of the 1.5 meter high, 1 x 1.5 meter table. The EUT, support equipment, and interconnecting cables were arranged and manipulated to maximize each emission. Appropriate precaution was taken to ensure that all emissions from the EUT were maximized and investigated. The system configuration, clock speed, mode of operation or video resolution, if applicable, turntable azimuth, and receive antenna height was noted for each frequency found.

Final measurements were made in the semi-anechoic chamber using calibrated, linearly polarized broadband and horn antennas. The test setup was configured to the setup that produced the worst case emissions. The spectrum analyzer was set to investigate all frequencies required for testing to compare the highest radiated disturbances with respect to the specified limits. The turntable containing the EUT was rotated through 360 degrees and the height of the receive antenna was varied 1 to 4 meters and stopped at the azimuth and height producing the maximum emission. Each emission was maximized by changing the orientation of the EUT through three orthogonal planes and changing the polarity of the receive antenna, which produced the worst-case emissions. According to 3dB Beam-Width of horn antenna, the horn antenna should be always directed to the EUT when rising height.

4. ANTENNA REQUIREMENTS

Excerpt from §15.203 of the FCC Rules/Regulations:

“An intentional radiator antenna shall be designed to ensure that no antenna other than that furnished by the responsible party can be used with the device. The use of a permanently attached antenna or of an antenna that uses a unique coupling to the intentional radiator shall be considered sufficient to comply with the provisions of this section.”

- The antenna of the device is **permanently attached**.
- There are no provisions for connection to an external antenna.

Conclusion:

The unit complies with the requirement of §15.203.

5. TEST EQUIPMENT CALIBRATION DATE

Conducted Emission - SR2

Instrument	Manufacturer	Type No.	Asset No.	Cali. Interval	Cali. Due Date
EMI Test Receiver	R&S	ESR3	MRTSUE06185	1 year	2020/04/15
Two-Line V-Network	R&S	ENV 216	MRTSUE06002	1 year	2020/06/13
Two-Line V-Network	R&S	ENV 216	MRTSUE06003	1 year	2020/06/13
Thermohygrometer	Testo	608-H1	MRTSUE06404	1 year	2020/08/08
Shielding Room	MIX-BEP	Chamber-SR2	MRTSUE06215	N/A	N/A

Radiated Emission - AC1

Instrument	Manufacturer	Type No.	Asset No.	Cali. Interval	Cali. Due Date
EMI Test Receiver	R&S	ESR7	MRTSUE06001	1 year	2020/08/01
PXA Signal Analyzer	Keysight	9030B	MRTSUE06395	1 year	2020/09/03
Loop Antenna	Schwarzbeck	FMZB 1519	MRTSUE06025	1 year	2020/11/10
Bilog Period Antenna	Schwarzbeck	VULB 9168	MRTSUE06172	1 year	2020/03/31
Broad Band Horn Antenna	Schwarzbeck	BBHA 9120D	MRTSUE06023	1 year	2020/10/13
Broad Band Horn Antenna	Schwarzbeck	BBHA 9170	MRTSUE06024	1 year	2019/12/17
Microwave System Amplifier	Agilent	83017A	MRTSUE06076	1 year	2019/11/16
Preamplifier	Schwarzbeck	BBV 9721	MRTSUE06121	1 year	2020/06/11
Thermohygrometer	Testo	608-H1	MRTSUE06403	1 year	2020/08/08
Anechoic Chamber	TDK	Chamber-AC1	MRTSUE06212	1 year	2020/04/30

Radiated Emission - AC2

Instrument	Manufacturer	Type No.	Asset No.	Cali. Interval	Cali. Due Date
Spectrum Analyzer	Keysight	N9038A	MRTSUE06125	1 year	2020/08/01
Loop Antenna	Schwarzbeck	FMZB 1519	MRTSUE06025	1 year	2020/11/10
Bilog Period Antenna	Schwarzbeck	VULB 9162	MRTSUE06022	1 year	2020/10/13
Horn Antenna	Schwarzbeck	BBHA9120D	MRTSUE06171	1 year	2020/10/27
Broad Band Horn Antenna	Schwarzbeck	BBHA 9170	MRTSUE06024	1 year	2019/12/17
Broadband Coaxial Preamplifier	Schwarzbeck	BBV 9718	MRTSUE06176	1 year	2020/11/15
Preamplifier	Schwarzbeck	BBV 9721	MRTSUE06121	1 year	2020/06/11
Temperature/Humidity Meter	Minggao	ETH529	MRTSUE06170	1 year	2019/12/13
Anechoic Chamber	RIKEN	Chamber-AC2	MRTSUE06213	1 year	2020/04/30

Conducted Test Equipment - TR3

Instrument	Manufacturer	Type No.	Asset No.	Cali. Interval	Cali. Due Date
EXA Signal Analyzer	Agilent	N9020A	MRTSUE06106	1 year	2020/04/15
EXA Signal Analyzer	Keysight	N9010B	MRTSUE06452	1 year	2020/07/11
Signal Analyzer	R&S	FSV40	MRTSUE06218	1 year	2020/04/15
Power Meter	Agilent	U2021XA	MRTSUE06030	1 year	2019/11/16
USB wideband power sensor	Keysight	U2021XA	MRTSUE06446	1 year	2020/06/30
USB wideband power sensor	Keysight	U2021XA	MRTSUE06447	1 year	2020/06/30
Bluetooth Test Set	Anritsu	MT8852B-042	MRTSUE06389	1 year	2020/06/13
Audio Analyzer	Agilent	U8903B	MRTSUE06143	1 year	2020/06/13
Modulation Analyzer	HP	8901A	MRTSUE06098	1 year	2020/10/10
Wideband Radio Communication Tester	R&S	CMW 500	MRTSUE06243	1 year	2020/11/07
DC Power Supply	GWINSTEK	DPS-3303C	MRTSUE06064	N/A	N/A
Temperature & Humidity Chamber	BAOYT	BYH-150CL	MRTSUE06051	1 year	2020/11/07
Thermohygrometer	testo	608-H1	MRTSUE06401	1 year	2020/08/08

Software	Version	Function
EMI Software	V3	EMI Test Software

6. MEASUREMENT UNCERTAINTY

Where relevant, the following test uncertainty levels have been estimated for tests performed on the EUT as specified in CISPR 16-4-2. This uncertainty represents an expanded uncertainty expressed at approximately the 95% confidence level using a coverage factor of $k = 2$.

AC Conducted Emission Measurement - SR2
Measurement Uncertainty for a Level of Confidence of 95% ($U=2Uc(y)$): 9kHz~150kHz: 3.84dB 150kHz~30MHz: 3.46dB
Radiated Emission Measurement - AC1
Measurement Uncertainty for a Level of Confidence of 95% ($U=2Uc(y)$): Horizontal: 30MHz~300MHz: 4.07dB 300MHz~1GHz: 3.63dB 1GHz~18GHz: 4.16dB Vertical: 30MHz~300MHz: 4.18dB 300MHz~1GHz: 3.60dB 1GHz~18GHz: 4.76dB
Radiated Emission Measurement - AC2
Measurement Uncertainty for a Level of Confidence of 95% ($U=2Uc(y)$): Horizontal: 30MHz~300MHz: 3.75dB 300MHz~1GHz: 3.53dB 1GHz~18GHz: 4.28dB Vertical: 30MHz~300MHz: 3.86dB 300MHz~1GHz: 3.53dB 1GHz~18GHz: 4.33dB

7. TEST RESULT

7.1. Summary

FCC Part Section(s)	Test Description	Test Limit	Test Condition	Test Result	Reference
15.247(a)(2)	6dB Bandwidth	$\geq 500\text{kHz}$	Conducted	Pass	Section 7.2
15.247(b)(3)	Output Power	$\leq 1\text{Watt}$		Pass	Section 7.3
15.247(e)	Power Spectral Density	$\leq 8\text{dBm} / 3\text{kHz}$		Pass	Section 7.4
15.247(d)	Band Edge / Out-of-Band Emissions	$\geq 20\text{dBc (Peak)}$		Pass	Section 7.5
15.205 15.209	General Field Strength Limits (Restricted Bands and Radiated Emission Limits)	Emissions in restricted bands must meet the radiated limits detailed in 15.209	Radiated	Pass	Section 7.6 Section 7.7
15.207	AC Conducted Emissions 150kHz - 30MHz	$< \text{FCC } 15.207 \text{ limits}$	Line Conducted	Pass	Section 7.8

Notes:

- 1) The analyzer plots shown in this section were all taken with a correction table loaded into the analyzer. The correction table was used to account for the losses of the cables and attenuators used as part of the system to connect the EUT to the analyzer at all frequencies of interest.
- 2) All modes of operation and data rates were investigated. For radiated emission test, every axis (X, Y, Z) was also verified. The test results shown in the following sections represent the worst case emissions.

7.2. 6dB Bandwidth Measurement

7.2.1. Test Limit

The minimum 6dB bandwidth shall be at least 500 kHz.

7.2.2. Test Procedure used

ANSI C63.10-2013 - Section 11.8 (6dB bandwidth)

7.2.3. Test Setting

1. The Spectrum's automatic bandwidth measurement capability was used to perform the 6dB bandwidth measurement. The "X" dB bandwidth parameter was set to $X = 6$. The bandwidth measurement was not influenced by any intermediate power nulls in the fundamental emission.
2. Set RBW = 100 kHz
3. VBW $\geq 3 \times$ RBW
4. Detector = Peak
5. Trace mode = Max hold
6. Sweep = Auto couple
7. Allow the trace was allowed to stabilize

7.2.4. Test Setup

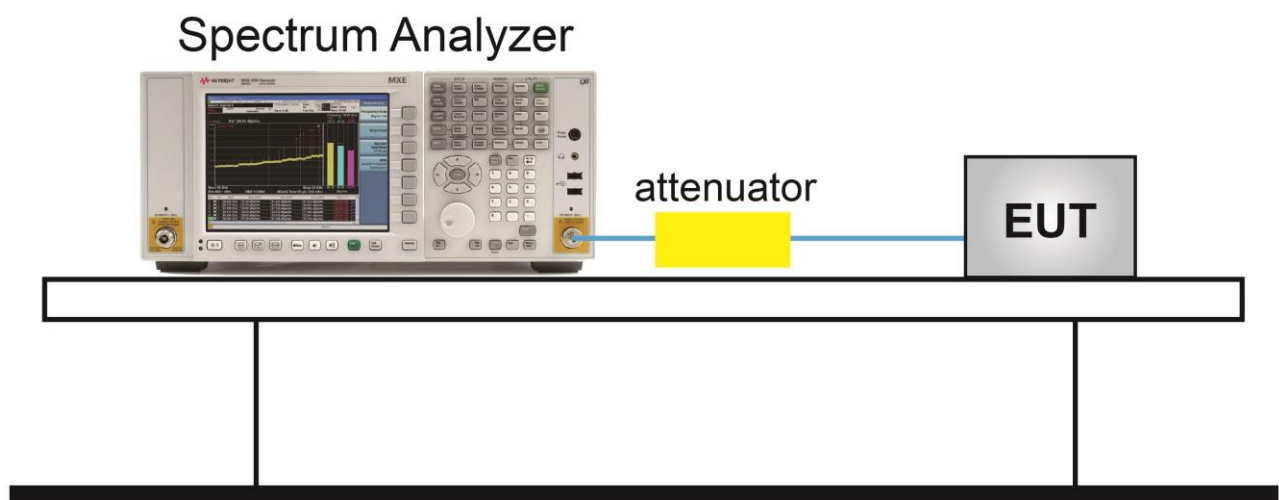

7.2.5. Test Result

Product	EZCast Ultra Wireless Display Receiver	Temperature	25°C
Test Engineer	Flay Yang	Relative Humidity	52%
Test Site	TR3	Test Date	2019/11/12 ~ 2019/12/10

Test Mode	Data Rate / MCS	Channel No.	Frequency (MHz)	6dB Bandwidth (MHz)	Limit (MHz)	Result
802.11b	1Mbps	01	2412	10.17	≥ 0.5	Pass
802.11b	1Mbps	06	2437	10.16	≥ 0.5	Pass
802.11b	1Mbps	11	2462	10.16	≥ 0.5	Pass
802.11g	6Mbps	01	2412	16.53	≥ 0.5	Pass
802.11g	6Mbps	06	2437	16.55	≥ 0.5	Pass
802.11g	6Mbps	11	2462	16.56	≥ 0.5	Pass
802.11n-HT20	MCS0	01	2412	17.70	≥ 0.5	Pass
802.11n-HT20	MCS0	06	2437	17.72	≥ 0.5	Pass
802.11n-HT20	MCS0	11	2462	17.69	≥ 0.5	Pass
802.11n-HT40	MCS0	03	2422	36.49	≥ 0.5	Pass
802.11n-HT40	MCS0	06	2437	36.48	≥ 0.5	Pass
802.11n-HT40	MCS0	09	2452	36.46	≥ 0.5	Pass

802.11b 6dB Bandwidth

Channel 01 (2412MHz)

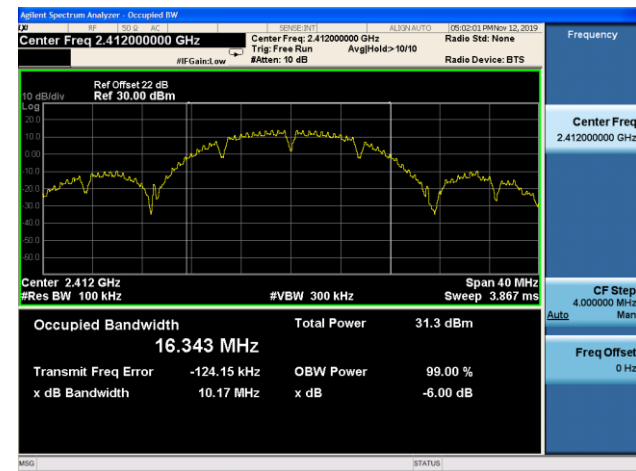

Channel 06 (2437MHz)

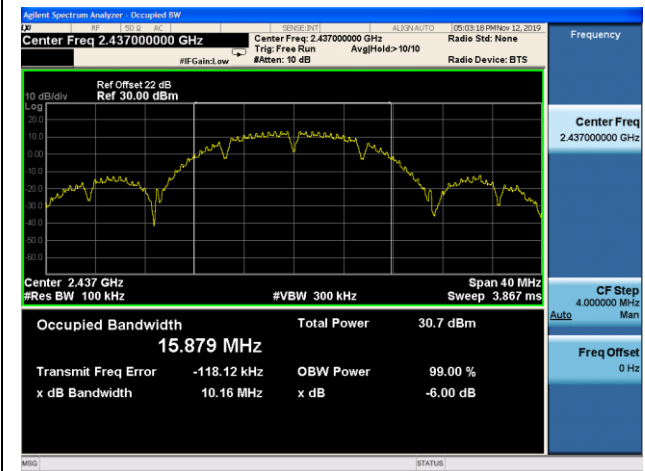

Channel 11 (2462MHz)

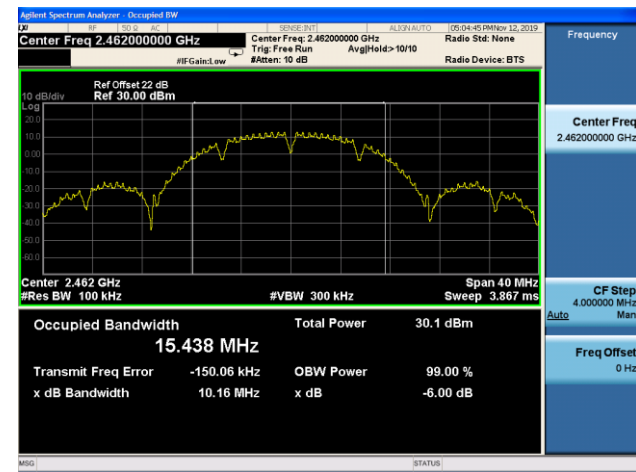

802.11g 6dB Bandwidth

Channel 01 (2412MHz)

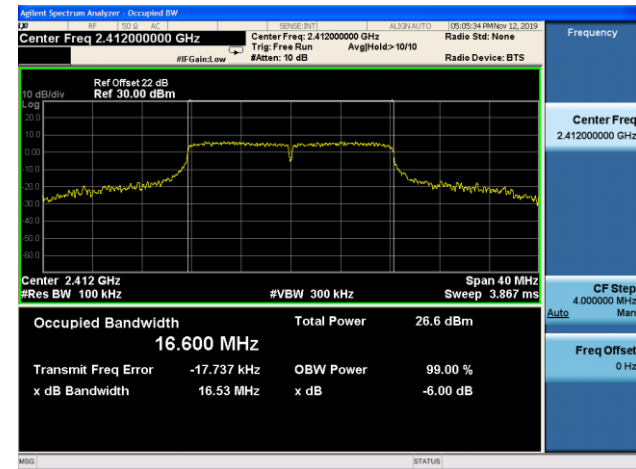

Channel 06 (2437MHz)



Channel 11 (2462MHz)

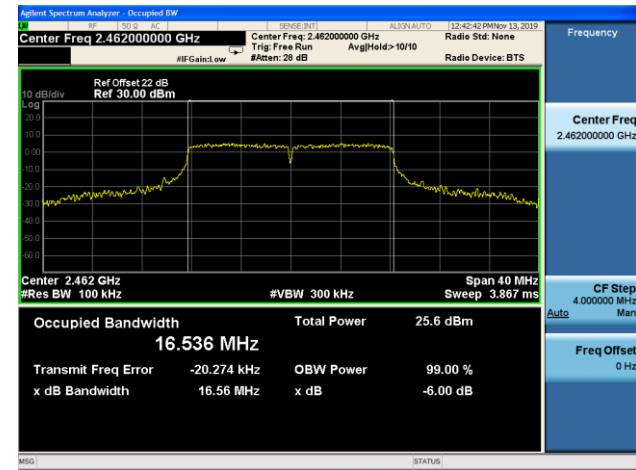

802.11n-HT20 6dB Bandwidth

Channel 01 (2412MHz)

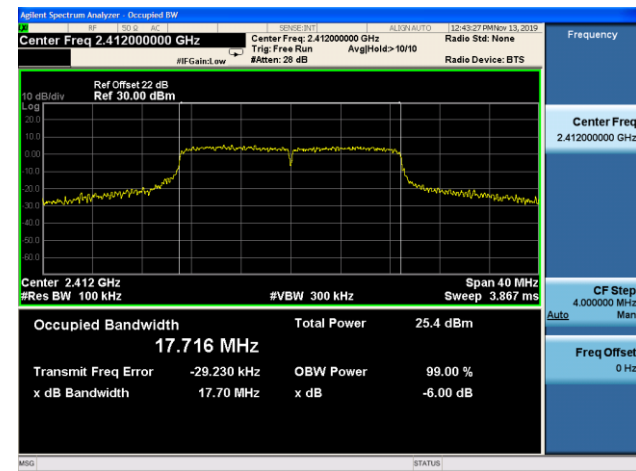

Channel 06 (2437MHz)

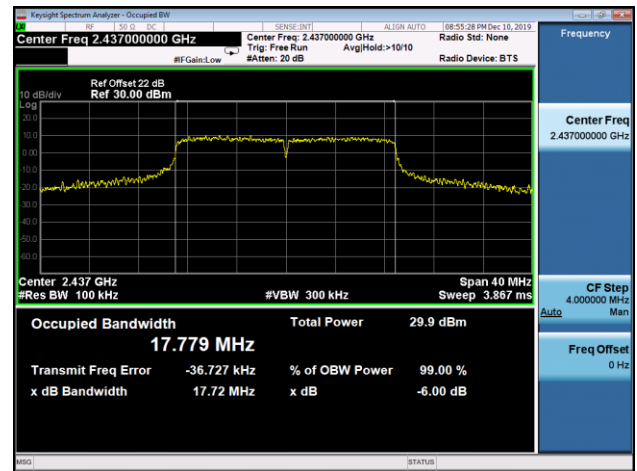

Channel 11 (2462MHz)

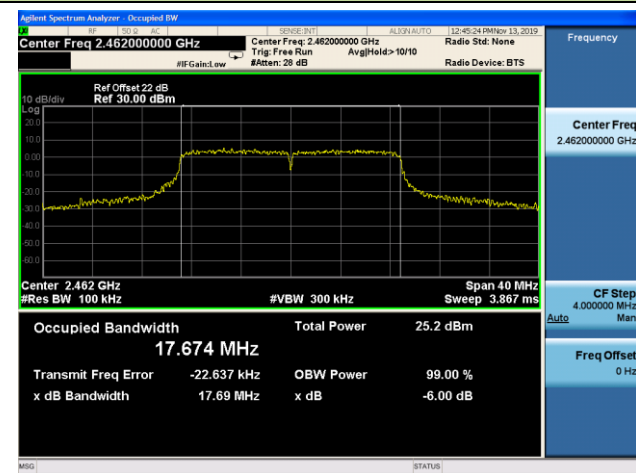

802.11n-HT40 6dB Bandwidth

Channel 03 (2422MHz)

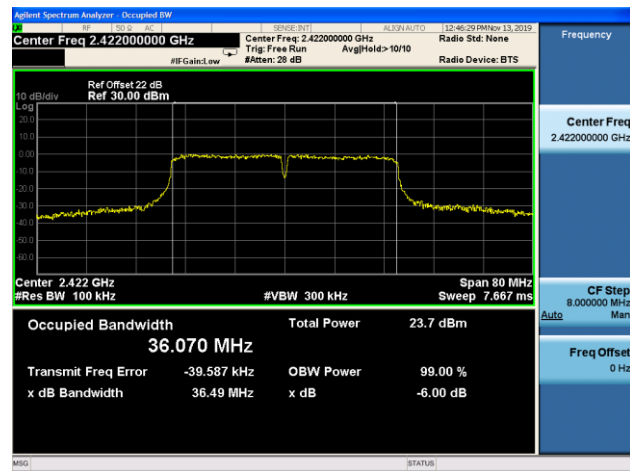

Channel 06 (2437MHz)

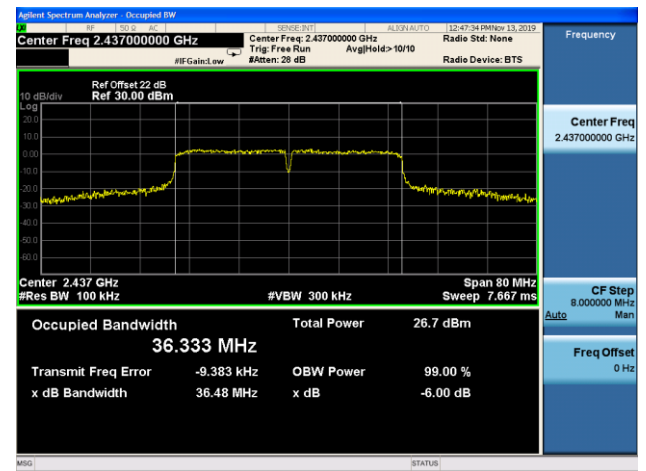

Channel 09 (2452MHz)

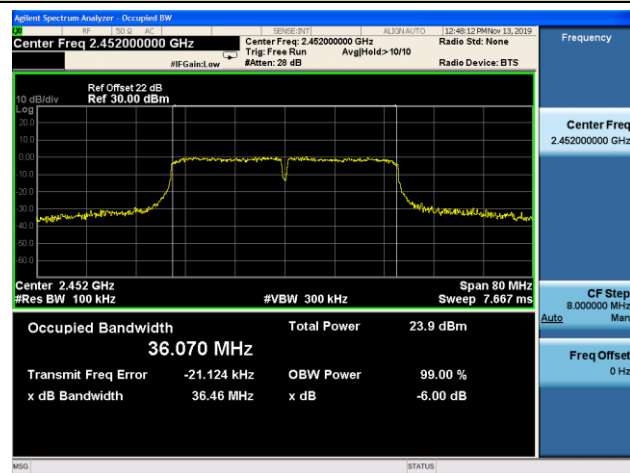

7.3. Output Power Measurement

7.3.1. Test Limit

The maximum conducted output power shall be less 1 Watt (30dBm).

7.3.2. Test Procedure Used

ANSI C63.10-2013 - Section 11.9.1.3

ANSI C63.10-2013 - Section 11.9.2.3

7.3.3. Test Setting

Method PKPM1 (Peak Power Measurement)

Peak power measurements were performed only when the EUT was transmitting at its maximum power control level using a broadband power meter with a pulse sensor. The pulse sensor employs a VBW = 50MHz so this method was only used for signals whose DTS bandwidth was less than or equal to 50MHz.

Method AVGPM-G (Measurement using a gated RF average-reading power meter)

Measurements may be performed using a wideband gated RF power meter provided that the gate parameters are adjusted such that the power is measured only when the EUT is transmitting at its maximum power control level. Since this measurement is made only during the ON time of the transmitter, no duty cycle correction is required.

7.3.4. Test Setup

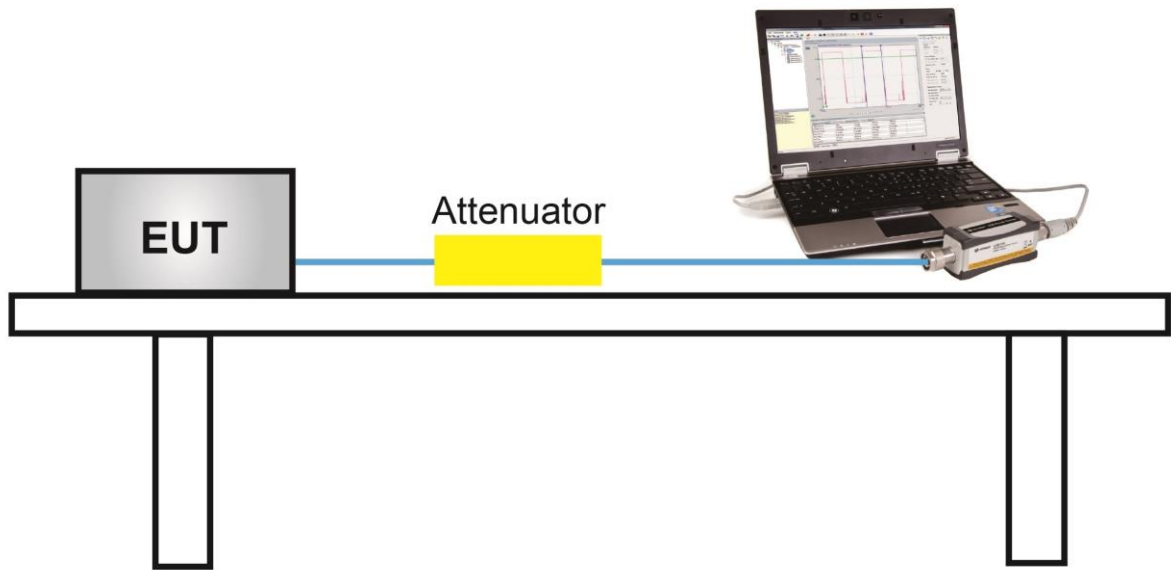

7.3.5. Test Result of Output Power

Power output test was verified over all data rates of each mode shown as below, and then choose the maximum peak power output (gray marker) for final test of each channel.

Test Mode	Bandwidth (MHz)	Channel No.	Frequency (MHz)	Data Rate / MCS	Peak Power (dBm)
802.11b	20	6	2437	1Mbps	25.63
				5.5Mbps	25.34
				11Mbps	25.10
802.11g	20	6	2437	6Mbps	26.55
				24Mbps	26.31
				54Mbps	26.18
802.11n	20	6	2437	MCS0	26.49
				MCS3	26.23
				MCS7	26.10
802.11n	40	6	2437	MCS0	26.47
				MCS3	26.28
				MCS7	26.12

Product	EZCast Ultra Wireless Display Receiver	Temperature	25°C
Test Engineer	Flay Yang	Relative Humidity	52%
Test Site	TR3	Test Date	2019/11/10

Test Result of Peak Output Power

Test Mode	Data Rate / MCS	Channel No.	Frequency (MHz)	Peak Power (dBm)	Limit (dBm)	Result
11b	1Mbps	01	2412	26.01	≤ 30.00	Pass
11b	1Mbps	06	2437	25.63	≤ 30.00	Pass
11b	1Mbps	11	2462	25.20	≤ 30.00	Pass
11g	6Mbps	01	2412	26.13	≤ 30.00	Pass
11g	6Mbps	06	2437	26.55	≤ 30.00	Pass
11g	6Mbps	11	2462	26.47	≤ 30.00	Pass
11n-HT20	MCS0	01	2412	25.95	≤ 30.00	Pass
11n-HT20	MCS0	06	2437	26.49	≤ 30.00	Pass
11n-HT20	MCS0	11	2462	25.82	≤ 30.00	Pass
11n-HT40	MCS0	03	2422	25.46	≤ 30.00	Pass
11n-HT40	MCS0	06	2437	26.47	≤ 30.00	Pass
11n-HT40	MCS0	09	2452	25.44	≤ 30.00	Pass

Test Result of Average Output Power (Reporting Only)

Test Mode	Data Rate / MCS	Channel No.	Frequency (MHz)	Average Power (dBm)	Limit (dBm)	Result
11b	1Mbps	01	2412	24.44	≤ 30.00	Pass
11b	1Mbps	06	2437	23.92	≤ 30.00	Pass
11b	1Mbps	11	2462	23.24	≤ 30.00	Pass
11g	6Mbps	01	2412	20.52	≤ 30.00	Pass
11g	6Mbps	06	2437	20.14	≤ 30.00	Pass
11g	6Mbps	11	2462	19.92	≤ 30.00	Pass
11n-HT20	MCS0	01	2412	19.72	≤ 30.00	Pass
11n-HT20	MCS0	06	2437	19.94	≤ 30.00	Pass
11n-HT20	MCS0	11	2462	19.42	≤ 30.00	Pass
11n-HT40	MCS0	03	2422	17.79	≤ 30.00	Pass
11n-HT40	MCS0	06	2437	18.68	≤ 30.00	Pass
11n-HT40	MCS0	09	2452	18.36	≤ 30.00	Pass

Note: The result of average output power is only for MPE evaluation.

7.4. Power Spectral Density Measurement

7.4.1. Test Limit

The maximum permissible power spectral density is 8dBm in any 3 kHz band.

The same method of determining the conducted output power shall be used to determine the power spectral density.

7.4.2. Test Procedure Used

ANSI C63.10-2013 - Section 11.10.2

7.4.3. Test Setting

1. Analyzer was set to the center frequency of the DTS channel under investigation
2. Span = 1.5 times the DTS channel bandwidth
3. RBW = 3kHz
4. VBW = 10kHz
5. Detector = Peak
6. Sweep time = Auto couple
7. Trace mode = Max hold
8. Trace was allowed to stabilize

7.4.4. Test Setup

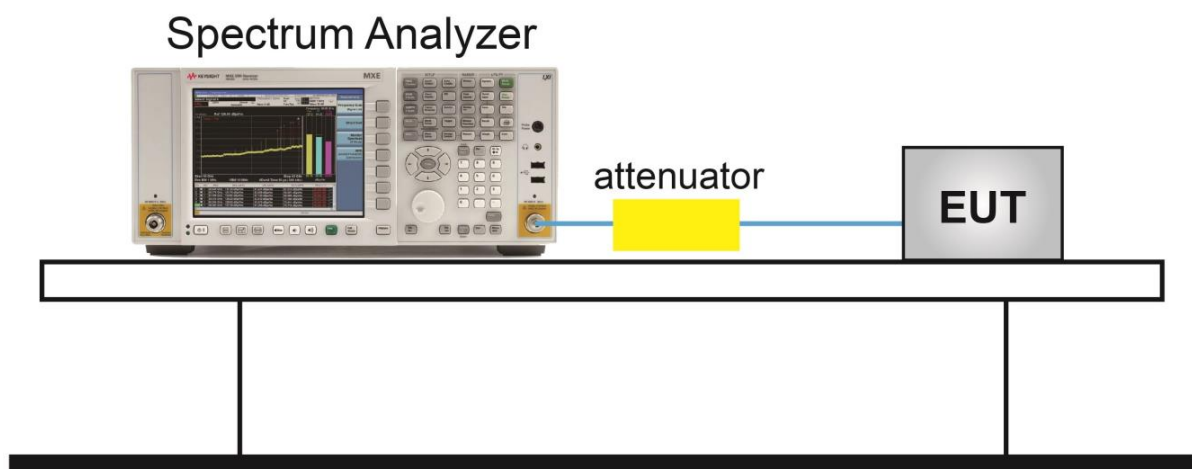

7.4.5. Test Result

Product	EZCast Ultra Wireless Display Receiver	Temperature	25°C
Test Engineer	Flay Yang	Relative Humidity	52%
Test Site	TR3	Test Date	2019/11/14

Test Mode	Data Rate / MCS	Channel No.	Frequency (MHz)	PK PSD (dBm / 3kHz)	Limit (dBm / 3kHz)	Result
11b	1Mbps	01	2412	-6.28	≤ 8.00	Pass
11b	1Mbps	06	2437	-6.90	≤ 8.00	Pass
11b	1Mbps	11	2462	-7.28	≤ 8.00	Pass
11g	6Mbps	01	2412	-8.20	≤ 8.00	Pass
11g	6Mbps	06	2437	-5.20	≤ 8.00	Pass
11g	6Mbps	11	2462	-8.50	≤ 8.00	Pass
11n-HT20	MCS0	01	2412	-8.36	≤ 8.00	Pass
11n-HT20	MCS0	06	2437	-4.62	≤ 8.00	Pass
11n-HT20	MCS0	11	2462	-9.15	≤ 8.00	Pass
11n-HT40	MCS0	03	2422	-12.85	≤ 8.00	Pass
11n-HT40	MCS0	06	2437	-9.99	≤ 8.00	Pass
11n-HT40	MCS0	09	2452	-11.69	≤ 8.00	Pass

802.11b PK PSD

Channel 01 (2412MHz)

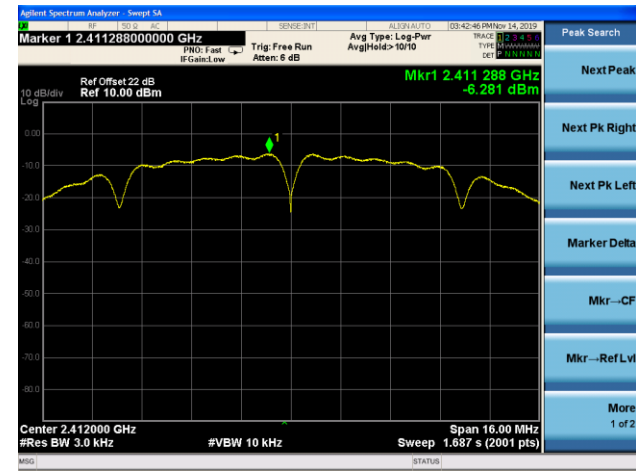

Channel 06 (2437MHz)

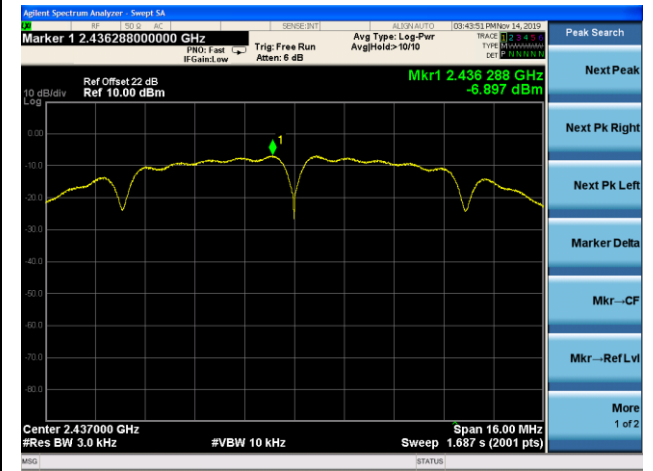

Channel 11 (2462MHz)

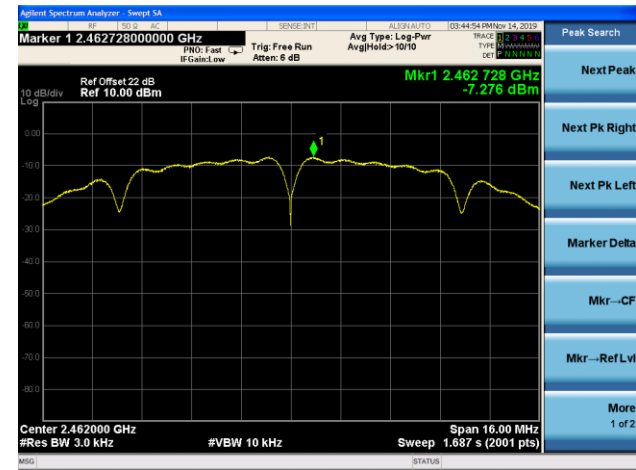

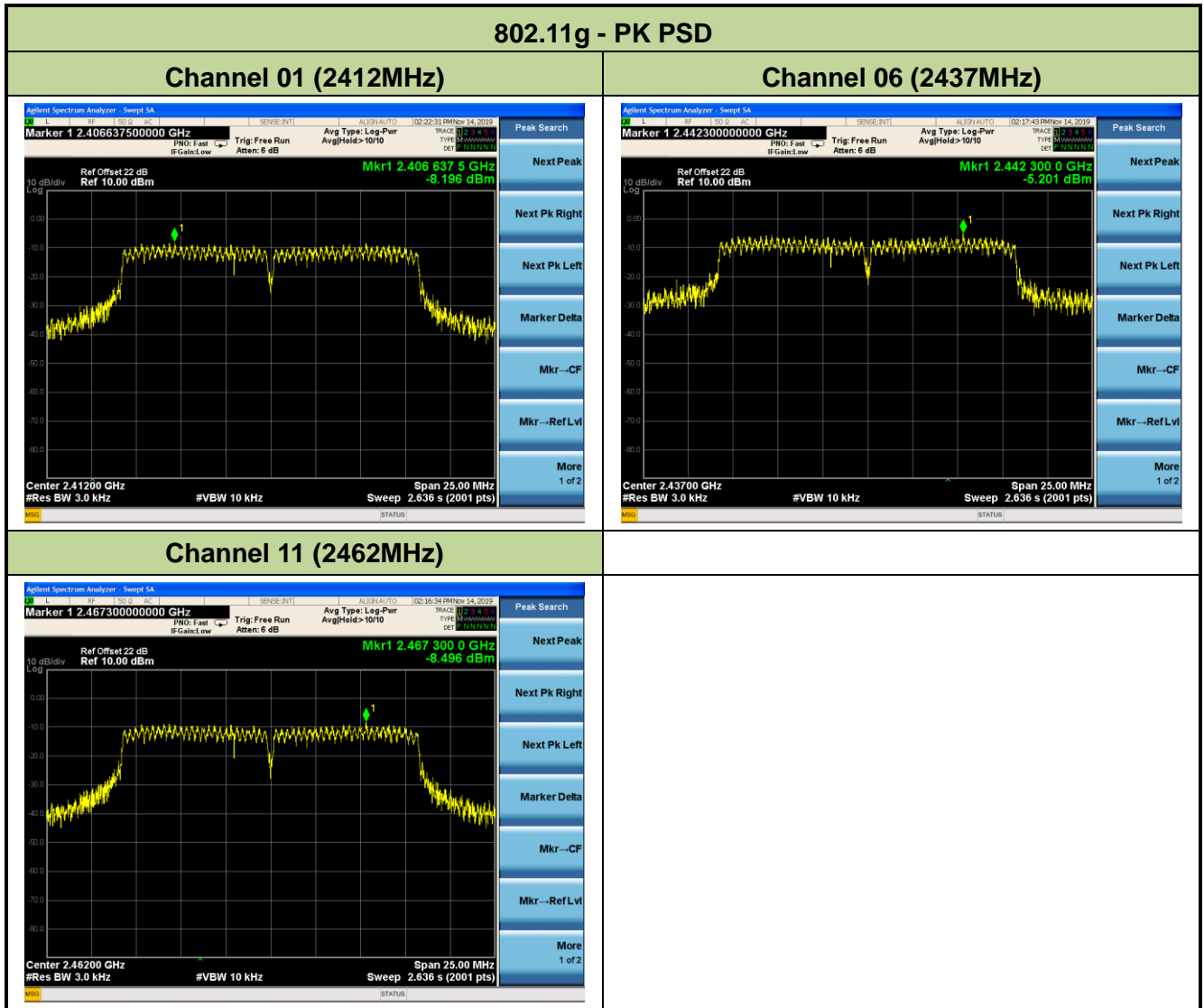

802.11n-HT20 - PK PSD

Channel 01 (2412MHz)

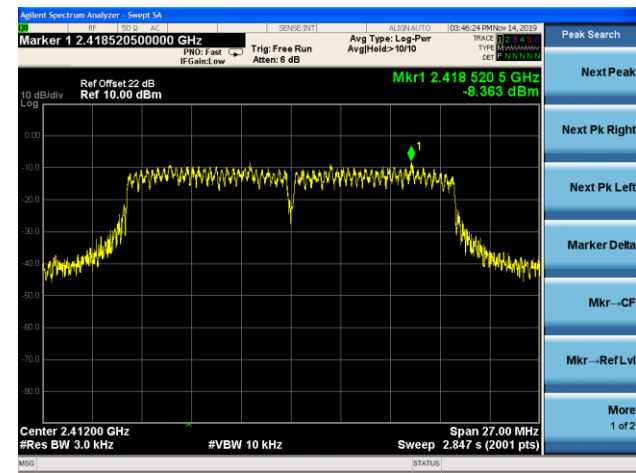

Channel 06 (2437MHz)

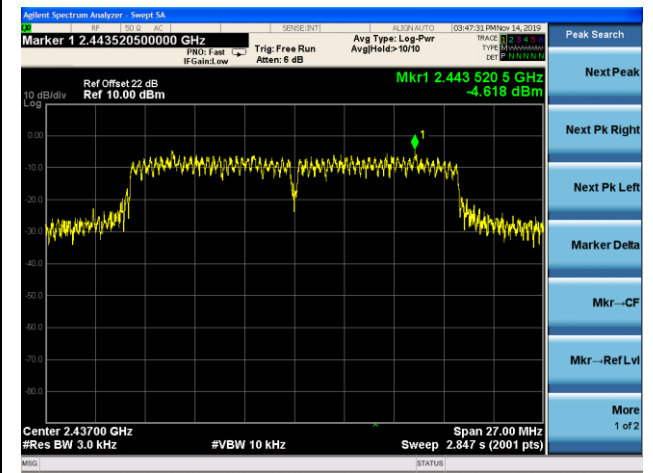

Channel 11 (2462MHz)

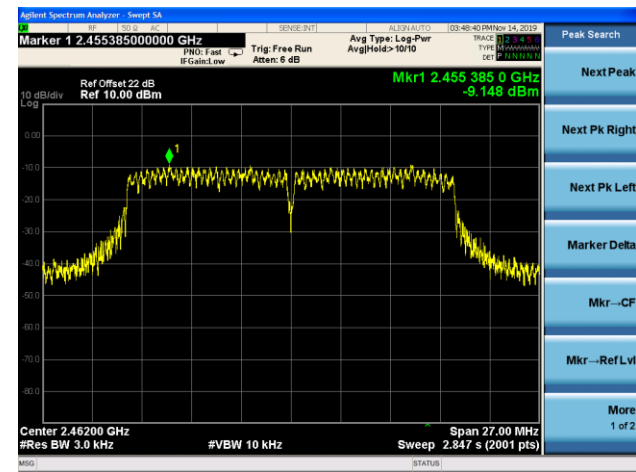

802.11n-HT40 - PK PSD

Channel 03 (2422MHz)

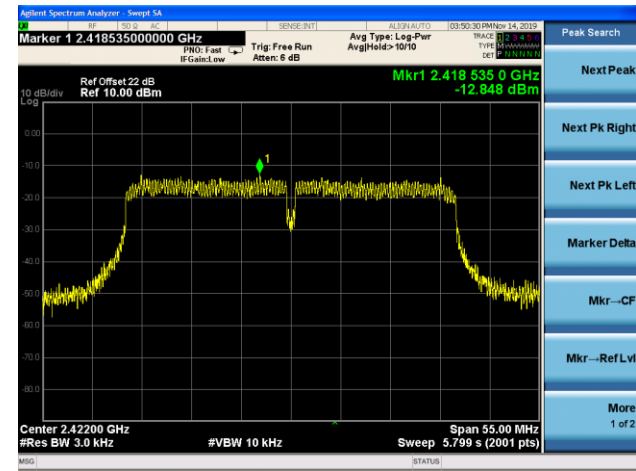

Channel 06 (2437MHz)

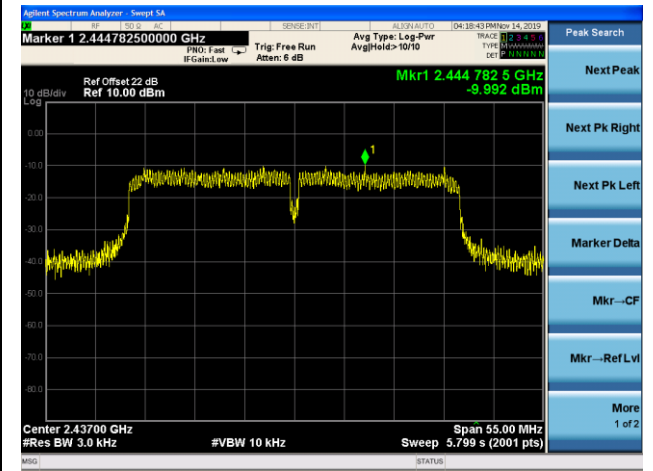

Channel 09 (2452MHz)

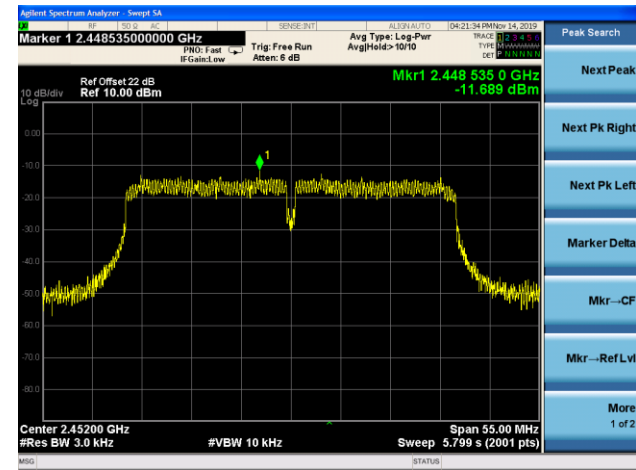

7.5. Conducted Band Edge and Out-of-Band Emissions

7.5.1. Test Limit

The limit for out-of-band spurious emissions at the band edge is 20dB below the fundamental emission level, as determined from the in-band power measurement of the DTS channel performed in a 100 kHz bandwidth per the PSD procedure.

7.5.2. Test Procedure Used

ANSI C63.10-2013 - Section 11.11

7.5.3. Test Setting

Reference level measurement

1. Set instrument center frequency to DTS channel center frequency
2. Set the span to ≥ 1.5 times the DTS bandwidth
3. Set the RBW = 100 kHz
4. Set the VBW $\geq 3 \times$ RBW
5. Detector = Peak
6. Sweep time = Auto couple
7. Trace mode = Max hold
8. Allow trace to fully stabilize

Emission level measurement

1. Set the center frequency and span to encompass frequency range to be measured
2. RBW = 100kHz
3. VBW = 300kHz
4. Detector = Peak
5. Trace mode = Max hold
6. Sweep time = Auto couple
7. The trace was allowed to stabilize

7.5.4. Test Setup

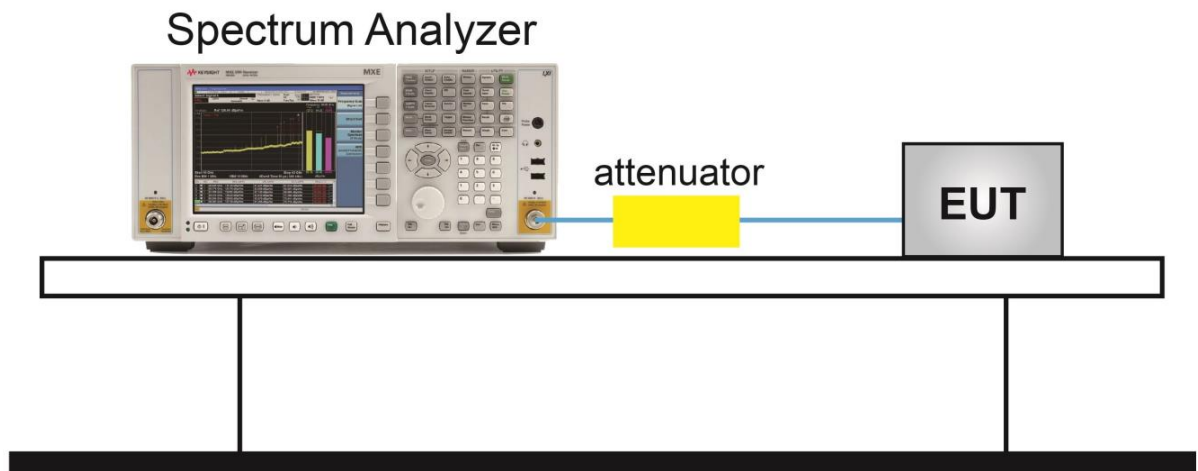

7.5.5. Test Result

Product	EZCast Ultra Wireless Display Receiver	Temperature	25°C
Test Engineer	Flay Yang	Relative Humidity	52%
Test Site	TR3	Test Date	2019/11/14

Test Mode	Data Rate / MCS	Channel No.	Frequency (MHz)	Limit	Result
802.11b	1Mbps	01	2412	20dBc	Pass
802.11b	1Mbps	06	2437	20dBc	Pass
802.11b	1Mbps	11	2462	20dBc	Pass
802.11g	6Mbps	01	2412	20dBc	Pass
802.11g	6Mbps	06	2437	20dBc	Pass
802.11g	6Mbps	11	2462	20dBc	Pass
802.11n-HT20	MCS0	01	2412	20dBc	Pass
802.11n-HT20	MCS0	06	2437	20dBc	Pass
802.11n-HT20	MCS0	11	2462	20dBc	Pass
802.11n-HT40	MCS0	03	2422	20dBc	Pass
802.11n-HT40	MCS0	06	2437	20dBc	Pass
802.11n-HT40	MCS0	09	2452	20dBc	Pass

802.11b Out-of-Band Emissions

Channel 01 (2412MHz)

100kHz PSD Reference Level

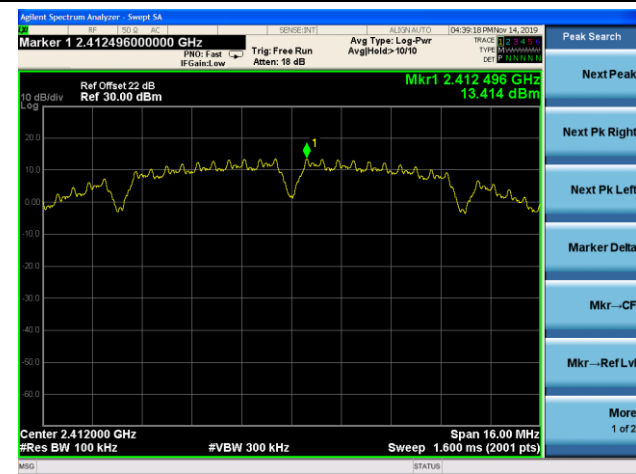

Low Band Edge

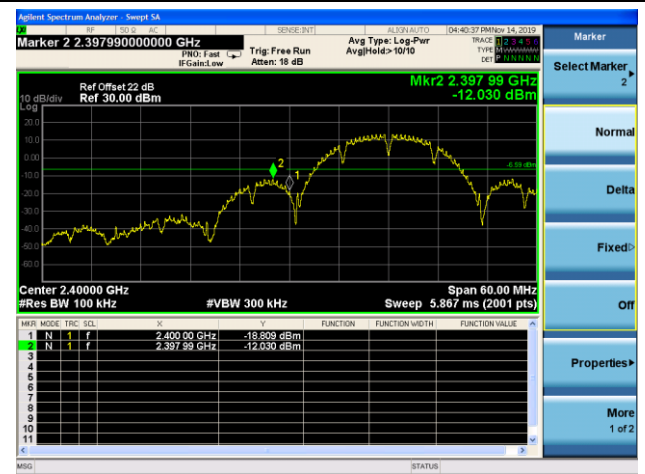

Spurious Emission

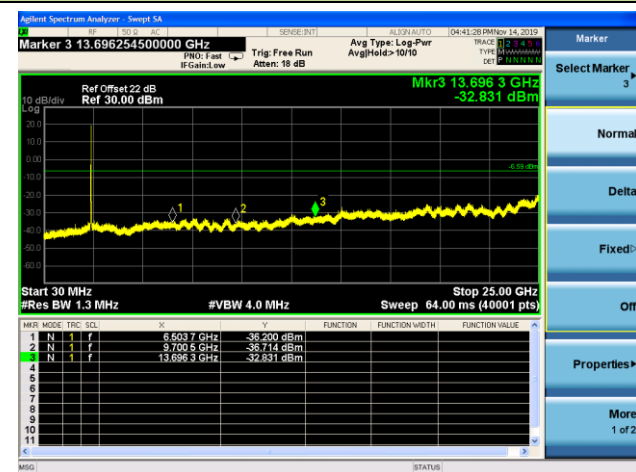

Channel 06 (2437MHz)

100kHz PSD Reference Level



Spurious Emission

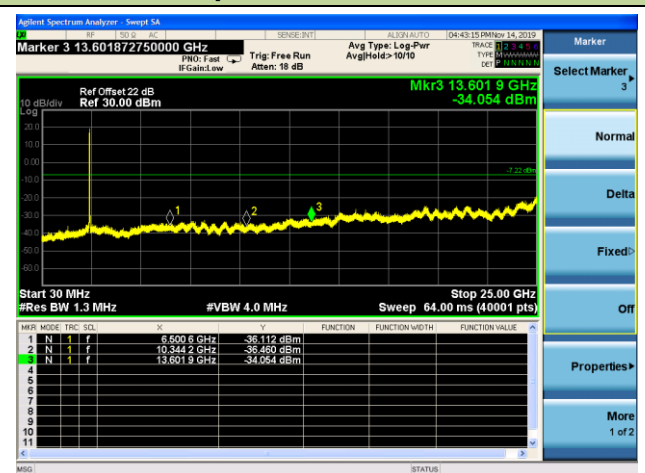

802.11b Out-of-Band Emissions Channel 11 (2462MHz)

100kHz PSD Reference Level



High Band Edge



Spurious Emission

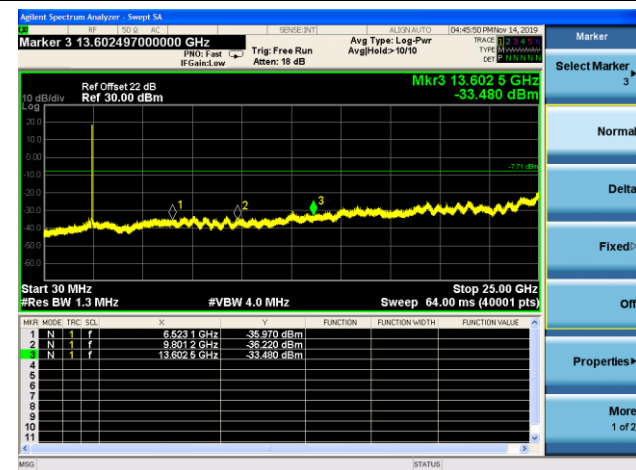

802.11g Out-of-Band Emissions

Channel 01 (2412MHz)

100kHz PSD Reference Level

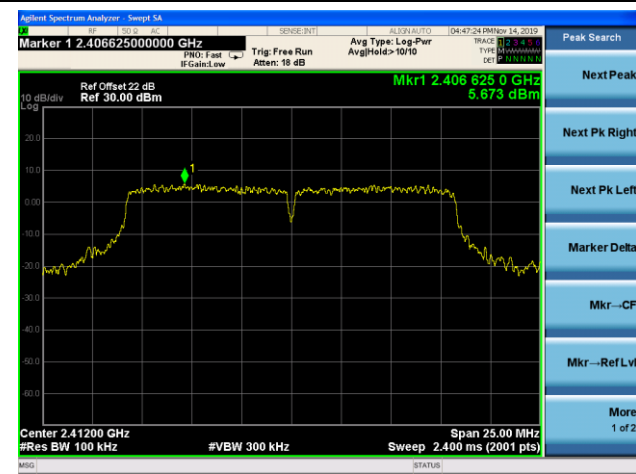

Low Band Edge

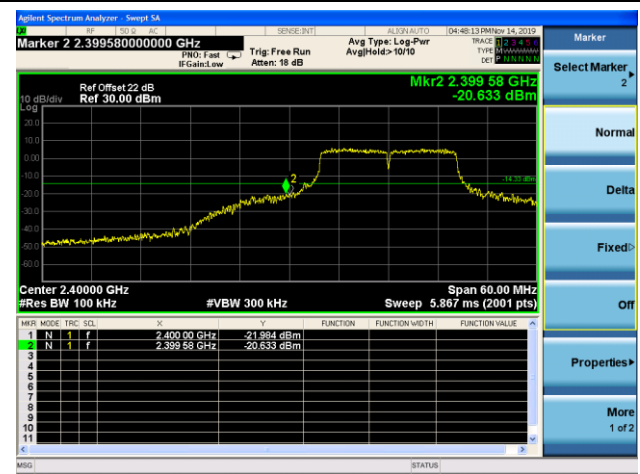

Spurious Emission

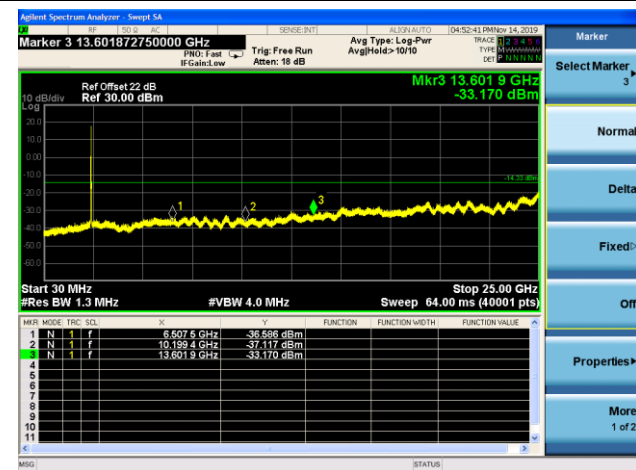

Channel 06 (2437MHz)

100kHz PSD Reference Level

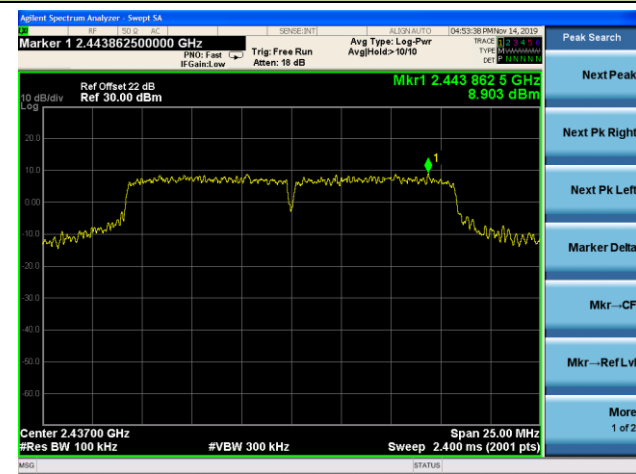

Spurious Emission

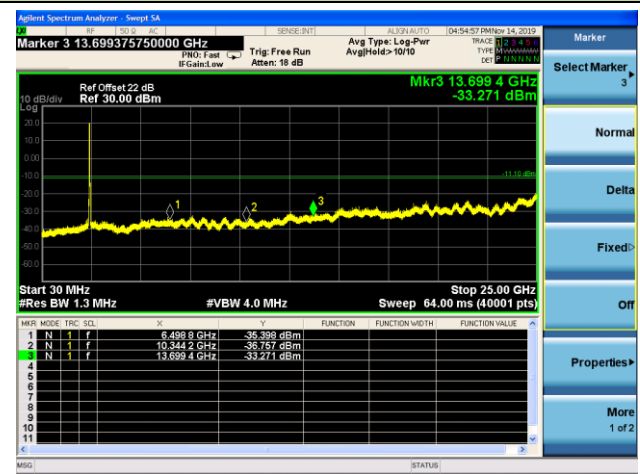

802.11g Out-of-Band Emissions Channel 11 (2462MHz)

100kHz PSD Reference Level

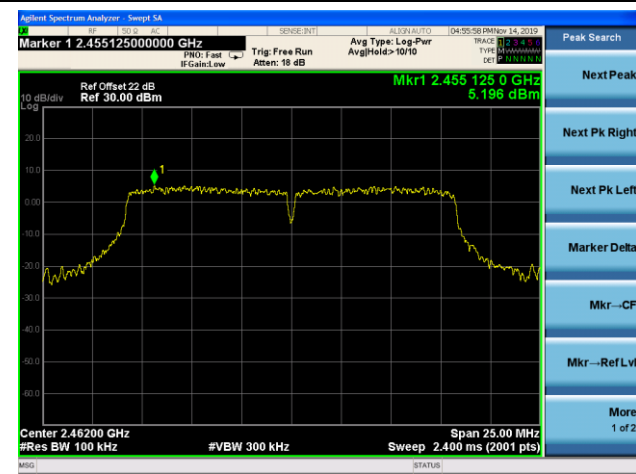

High Band Edge

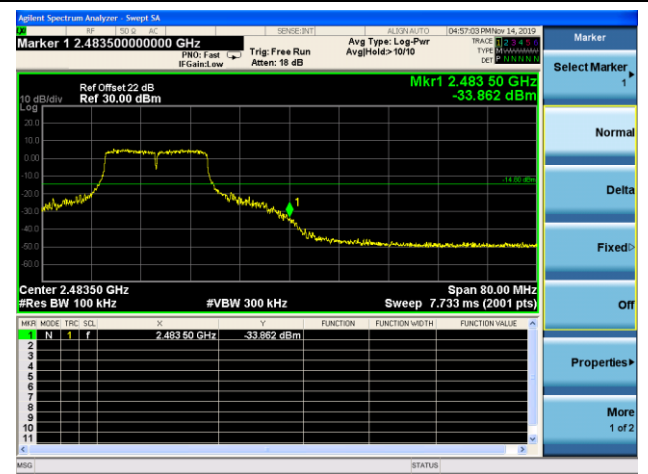

Spurious Emission

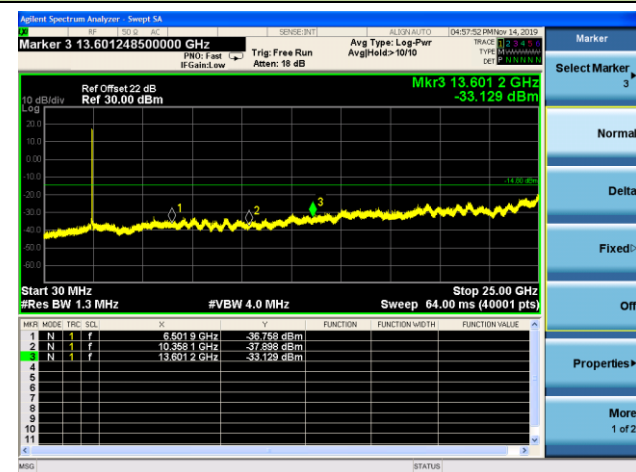

802.11n-HT20 Out-of-Band Emissions

Channel 01 (2412MHz)

100kHz PSD Reference Level

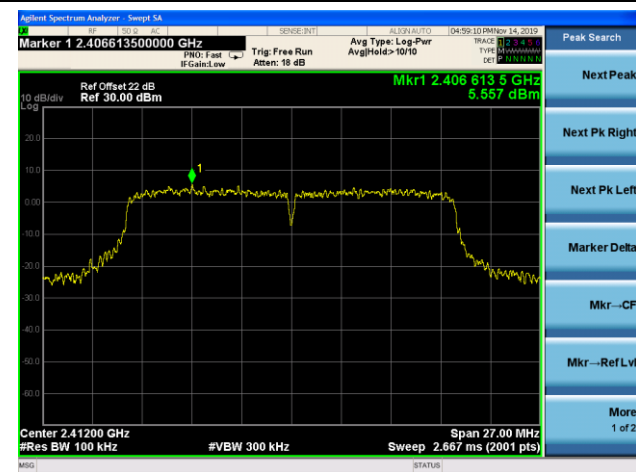

Low Band Edge

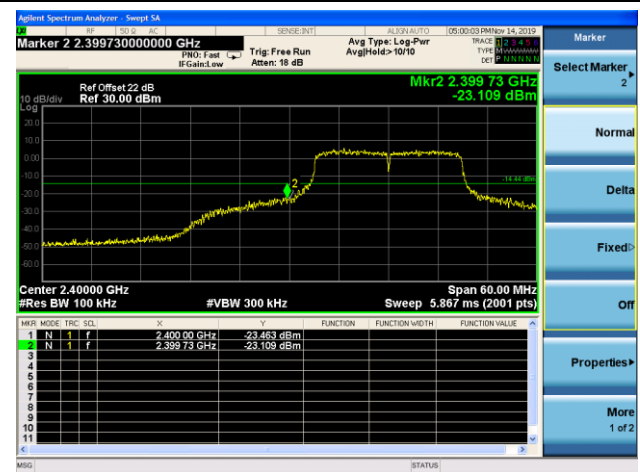

Spurious Emission

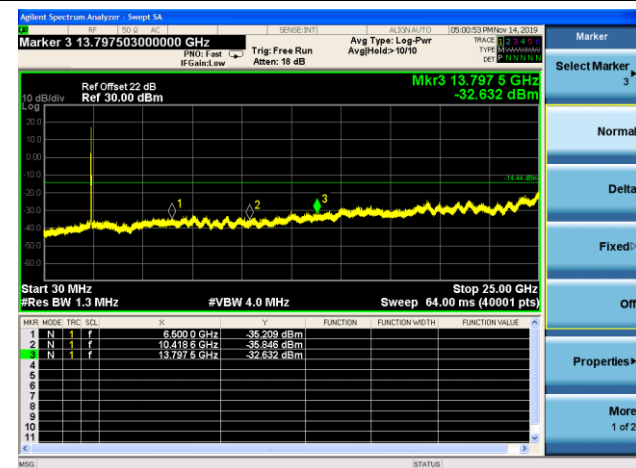

Channel 06 (2437MHz)

100kHz PSD Reference Level

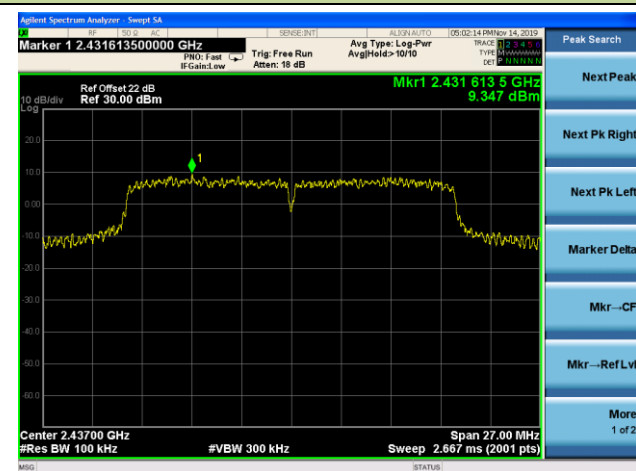

Spurious Emission

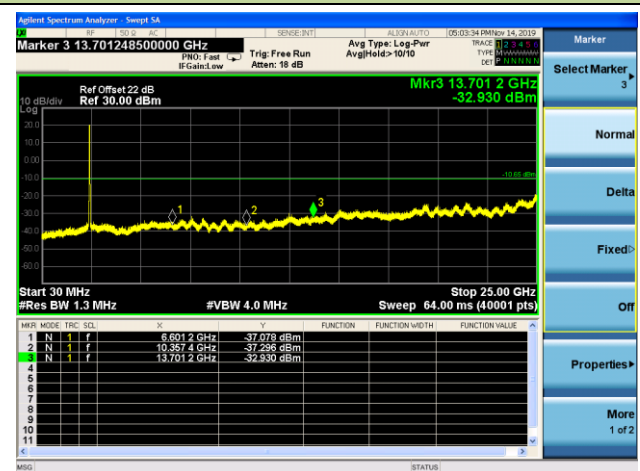

802.11n-HT20 Out-of-Band Emissions

Channel 11 (2462MHz)

100kHz PSD Reference Level

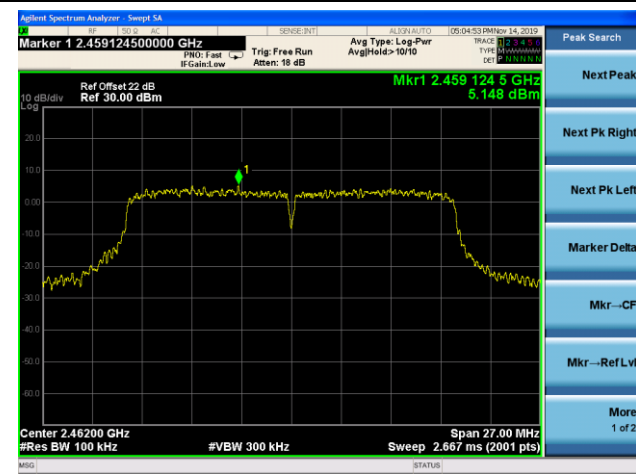

High Band Edge

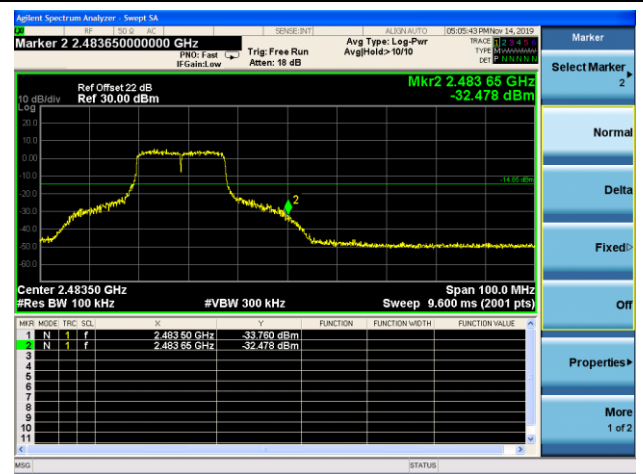

Spurious Emission

