

**Technical Manual of  
Century AM-EAS Systems  
Based on CAB68  
V1.0**



Copyright © 2019 Hangzhou Century Co., Ltd. All rights reserved.

# Table of Contents

<b>1</b>	<b>SYSTEM OVERVIEW</b> .....	<b>2</b>
1.1	The Main Features of Century AM-EAS Systems .....	2
1.2	Important Safety Precautions .....	3
<b>2</b>	<b>SYSTEM CONCEPTS</b> .....	<b>4</b>
<b>3</b>	<b>CONFIGURATION</b> .....	<b>5</b>
3.1	Hardware .....	5
3.1.1	<b>Volume</b> .....	5
3.2	Configuring System by Software .....	5
3.3	Configuring Communication Module .....	5
<b>4</b>	<b>INSTALLATION</b> .....	<b>6</b>
4.1	Connection .....	6
5.1.1LC/XC and LS/XS	.....	6
4.2	Modes of Combinations .....	7
4.2.1	<b>Single-Antenna</b> .....	7
4.2.2	<b>Dual-Antenna</b> .....	7
4.2.3	<b>Tri-Antenna</b> .....	7
5.2.5	<b>Checkout Control</b> .....	8
5.2.6	<b>Detect Ranges</b> .....	8
4.3	Installation Notes .....	9
4.3.1	<b>Requirements on Environment</b> .....	9
4.3.2	<b>Requirements on Power Source</b> .....	9
<b>5</b>	<b>TROUBLESHOOTING</b> .....	<b>9</b>
5.1	External Environment .....	9
5.2	System .....	9
<b>6</b>	<b>Specifications</b> .....	<b>10</b>
<b>7</b>	<b>Technical Support</b> .....	<b>14</b>

# 1 SYSTEM OVERVIEW

CENTURY Acoustic-Magnetic (AM)EAS systems introduced in the manual are all based on CAB58 electronics – the latest development based on 20-year experience in EAS industry and 10-year experience in R&D and production of EAS systems.

## 1.1 The Main Features of Century AM-EAS Systems

(1) Complying with worldwide practical requirement on frequency and operating principle in EAS industry.

- No special interfere to the other AM systems to obtain unfair advantages.
- Work with all tags with 58 KHz central frequency.

(2) Complying with corresponding CE directives.

- Safe in application.
- Legal to promote in EU countries.

(3) Integrate all electronics inside the antennas.

- No external/separate controller required
- One antenna can work independently.
- Real plug-n-play.

(4) Air synchronization

- No need for synchronization among nearby antennas by cables.
- Simple installation. Saving installation cost tremendously.

(5) Energy efficient

- Low power consumption

(6) Multi-window verification

- Enhanced noise immunity

(7) Tag-Too-Close alert

- Identifying reason of false alarm caused by nearby tag simply. Saving service cost.

(8) Relay outputs for CCTV application (normally open)

(9) Alarm messages can be pushed to management platform

(10) Background light (permanent)

- Attractive and strong alert to potential thefts.

(11) Adjustable alarm sound speed and duration.

(12) One master antenna can work with two slave antennas

(13) Remote tuning/service

- Responding to clients' service request quickly.
- Enhancing clients' satisfaction.
- Saving service cost tremendously.

(14) System status monitoring (online & offline)

- Guaranteeing continuous operation of the system.

(15) Alarm counting.

- Following handling results.
- Finding possible defects of the system.





(16) Oscilloscope in tuning software

- No need to bring physical oscilloscope for installation and service.
- Intuitively help technicians to set parameters properly.
- Help technicians to identify source of interference.







(17) Remote controller for the simplest adjustment

- Easy to bring with.
- Most of parameters can be set with.
- Experienced technicians can use it for tuning of 95% of systems on sites.

## 1.2 Important Safety Precautions

 <b>WARNING</b>	<p>The electronics inside antennas are extremely sensitive to electrostatic discharges. Always discharge yourself by touching a ground point before touching any of the electronics to avoid damaging the circuits.</p>
 <b>WARNING</b>	<p>Some parts of AM electronics are with high voltage. When power is on, do not touch metal parts; solder points, PCB radiator or other non-isolated places.</p>
 <b>PRECAUTION</b>	<p>All AMS devices should be powered from the mains supplied by power plants. The power generated by self-owned generator may result in bad synchronization among systems. Also, the outlet must have high quality grounding.</p>
 <b>PRECAUTION</b>	<p>The electricity supplied to the systems shall not be shared with other electronic or electric loads, e.g. electronic transformers, neon/spot lights, electrical engines, computers, LCD screens and cash registers, etc.</p>
 <b>PRECAUTION</b>	<p>“Dead” (not working) antenna(s) close to working antenna(s) will cause serious interference to the working antenna(s). To avoid the interference, RX- and RX+ of the “dead” antenna(s) must be short circuited. The use of the prepared short-circuit connector is shown as below.</p>

## 2 SYSTEM CONCEPTS

<b>Antenna frame</b>	Atento Classic (CA78L/F1)		Vista 2.1 Classic ( CA79L/F2)	
				
	Atento Grand (CA78X/F1)		Vista 2.1 Grand ( CA79X/F2)	
				
<b>Cables</b>	Power cable for LC/XC: 3m	Cable between LC/XC and LS/XS: 5m		Configuration cable: 2.4m
				
Note: The configuration cable between LC/XC and LS/XS includes a 4-core cable and a net cable.				

### 3 CONFIGURATION

#### 3.1 Hardware

##### 3.1.1 Volume

Description	VR1	VR2
Function	Potentiometer for adjusting buzzer's sound level of LC/XC. Clockwise for louder sound, and anti-clockwise for lighter sound.	Potentiometer for adjusting buzzer's sound level of LS/XS. Clockwise for louder sound, and anti-clockwise for lighter sound.

#### 3.2 Configuring System by Software

Please refer to "AMC-G58 User Manual".

#### 3.3 Configuring Communication Module

Please refer to "Communication Module Configuration".

## 4 INSTALLATION

There are different modes of combinations of antennas. The most commonly used mode of installation is transceiver antenna installation. So, it will be mainly introduced in this manual.

### 4.1 Connection

#### 5.1.1 LC/XC and LS/XS

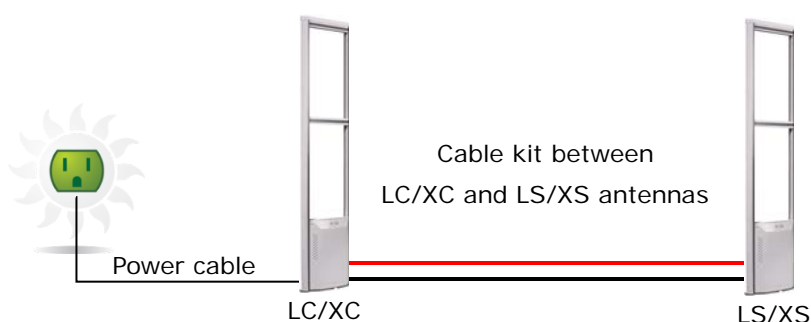

#### Attention:

- If the power cable between antennas is not long enough, the length of cable can be increased according to technical specifications. The maximum length is 50 meters.
- When the power cable, which is used to connect master antennas to 220V/110V power socket, needs to be buried under the ground, it has to be protected by metal or PVC pipe, complying with the installation requirements in different countries.
- If the cable kit for connecting LC/XC and LS/XS antennas is not long enough, the length of cable kit can be increased according to technical specifications. The maximum length is 10 meters.
- When the cable kit, which is used to connect LC/XC and LS/XS antennas, needs to be buried under the ground, it has to be protected by metal or PVC pipe, complying with the installation requirements in different countries.
- For re-assembling the connection plug, please follow the instruction of section 3.4.2.
- The recommended distance between antennas has considered certain level of environmental interference when two yellow LEDs light up.
- When both labels and hard tags are used, the recommended distance between antennas shall be based on performance of labels.

## 4.2 Modes of Combinations

### 4.2.1 Single-Antenna

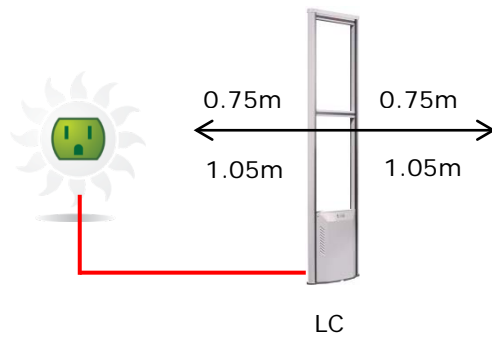

### 4.2.2 Dual-Antenna

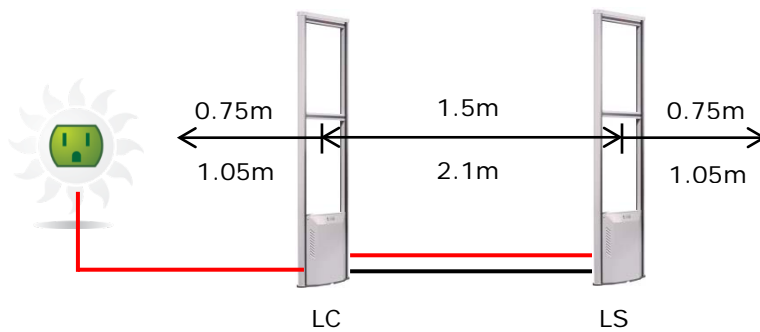

### 4.2.3 Tri-Antenna

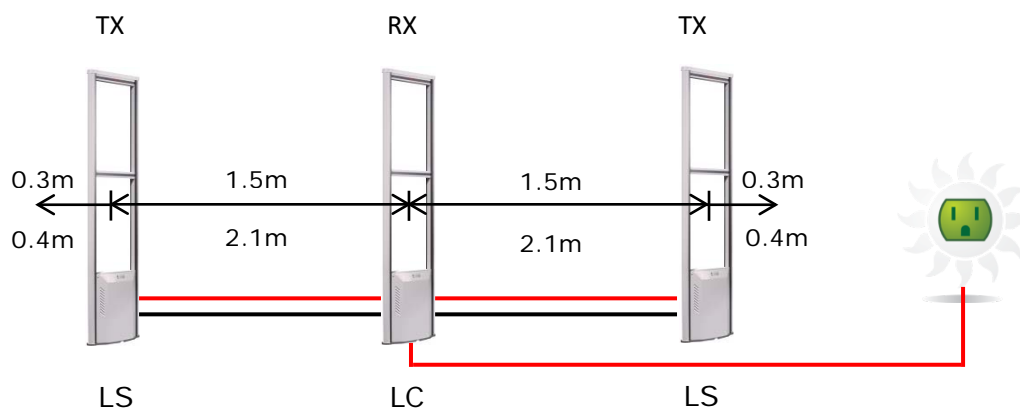



## 5.2.4 Multi-Channel

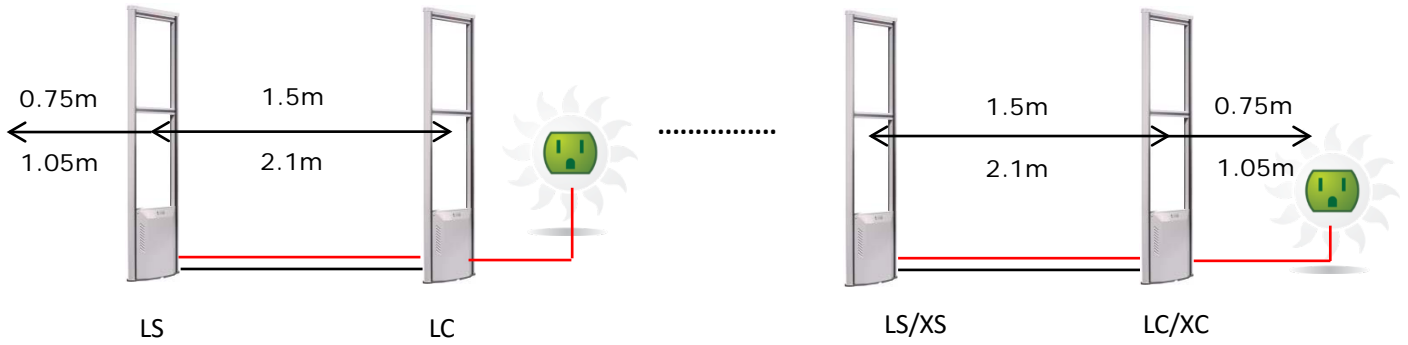

## 5.2.5 Checkout Control

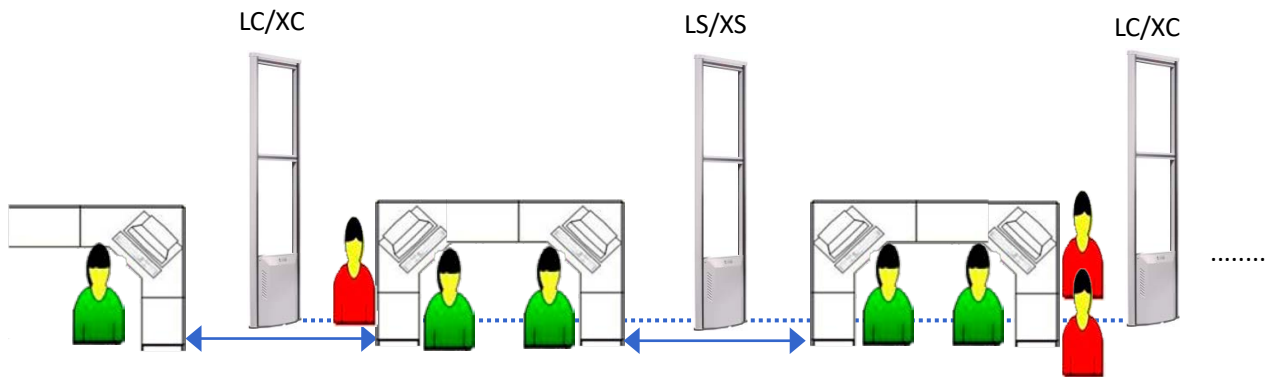

## 5.2.6 Detect Ranges

Antenna	Soft label (RS01)		Hard label (T041)	
	Detection on both sides(cm)	Detection in between(cm)	Detection on both sides(cm)	Detection in between(cm)
CA78	75	150	105	210
CA78X	90	180	110	220
CA79L/F2	75	150	105	210
CA79X/F2	90	180	110	220

## 4.3 Installation Notes

### 4.3.1 Requirements on Environment

- 1 Ensure the antenna is installed in environment with good ventilation.
- 2 Ensure the environment is clean and dry.
- 3 Ensure there is no possibility for water to enter into the antenna frame.
- 4 Ensure there is no large metal object, such as metal door frame, cabinet or shopping cart close to antenna.
- 5 Ensure that there is no 58KHz tag close to the antenna.

### 4.3.2 Requirements on Power Source

1. All antennas within 40m shall use the same 220VAC power source, and the neutral wire and live wire must be at the same position, i.e. neutral on the left and live on the right.
2. High quality grounding (at distribution box): the voltage between live and ground shall be 220VAC.
3. Power supplied by UPS or private generator is not acceptable.
4. The live wire shall not connect to any dynamic electricity. The live wire is better to use the same power source for lighting systems.

## 5 TROUBLESHOOTING

### 5.1 External Environment

1. Make sure that the power supply of the socket is independent (do not share with other electrical equipment), and the power socket has a good grounding (can use multimeter to test the voltage between phase wire and the ground which should be 110V or 220V).
2. Make sure the voltage of power supply is normal.
3. 58KHz tags must be 3m or further from the antenna.

### 5.2 System

Please refer to "AMC-G58 User Manual".

# 6 Specifications

Dimensions(mm)

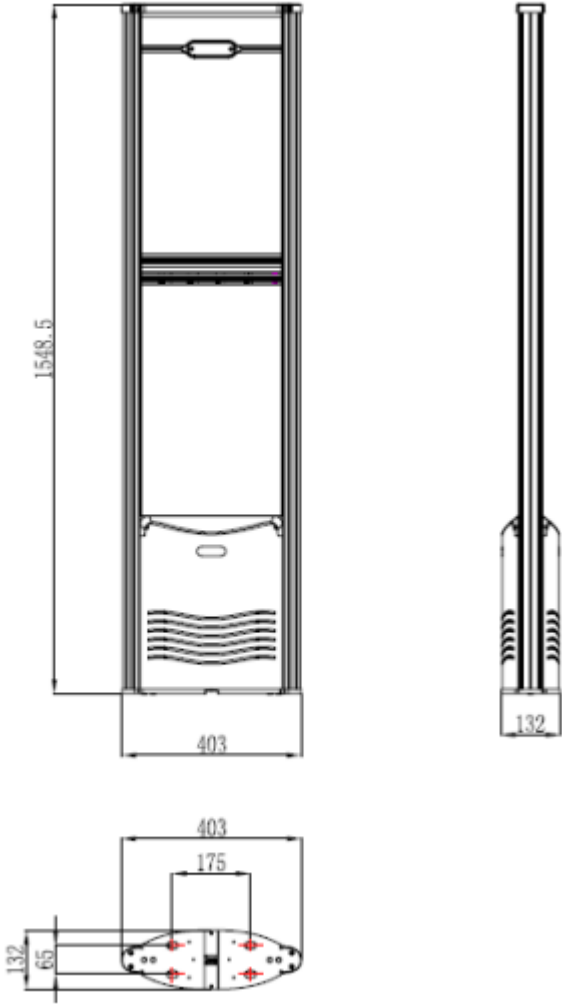

CA78

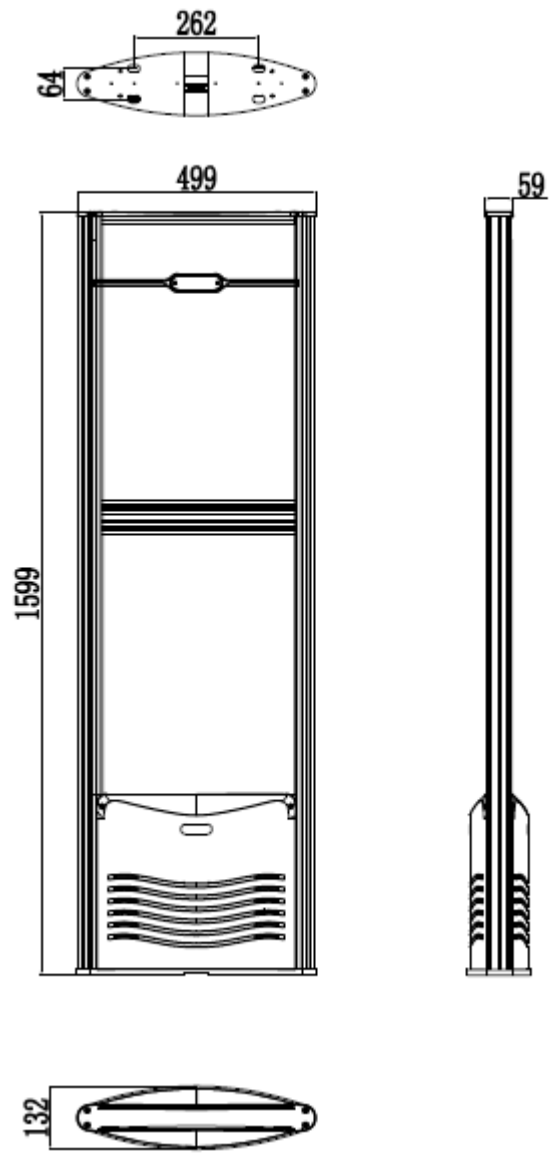

CA78X

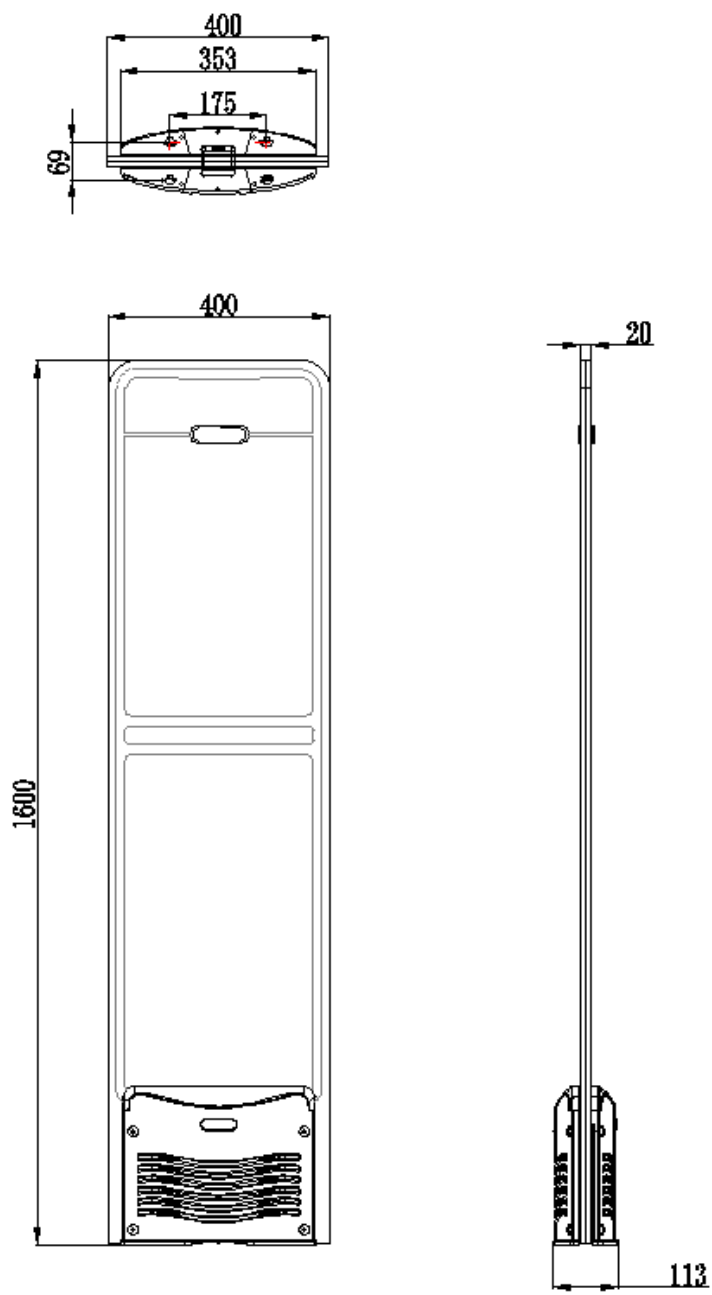

CA79L/F2

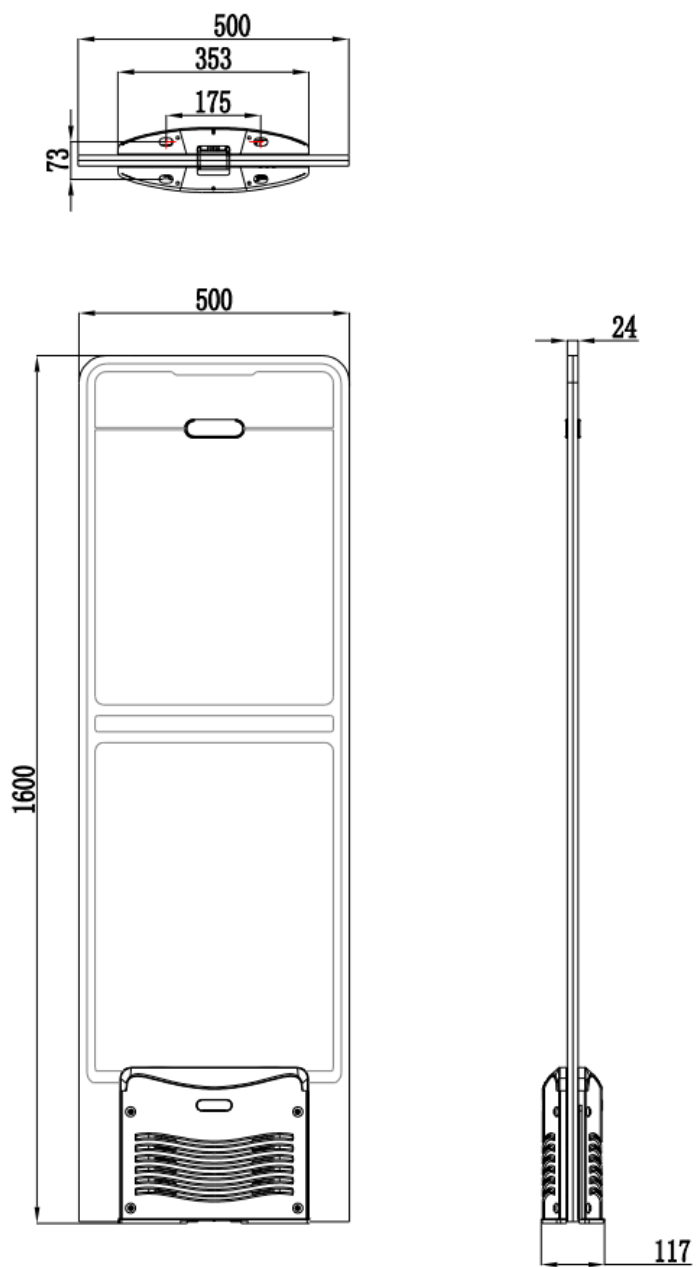

CA79X/F2

## 7 Technical Support

If you have any questions or suggestions about the Essential Series of Century AM systems, please do not hesitate to contact our technical support by email [technicalsupport@century-cn.com](mailto:technicalsupport@century-cn.com), or our salespersons directly.

### FCC

This device contains FCC ID: 2AP7X-DRM3

This device complies with part 15 of the FCC Rules. Operation is subject to the following two conditions:

- (1) This device may not cause harmful interference.
- (2) This device must accept any interference received, including interference that may cause undesired operation.

Caution the user that changes or modifications not expressly approved by the party responsible for compliance could void the user's authority to operate the equipment.

#### IMPORTANT NOTE:

##### FCC Radiation Exposure Statement:

This equipment complies with FCC radiation exposure limits set forth for an uncontrolled environment. This equipment should be installed and operated with a minimum distance of 20mm between the radiator & your body. This transmitter must not be co-located or operating in conjunction with any other antenna or transmitter.

This equipment has been tested and found to comply with the limits for a Class B digital device, pursuant to part 15 of the FCC Rules. These limits are designed to provide reasonable protection against harmful interference in a residential installation. This equipment generates, uses and can radiate radio frequency energy and, if not installed and used in accordance with the instructions, may cause harmful interference to radio communications. However, there is no guarantee that interference will not occur in a particular installation. If this equipment does cause harmful interference to radio or television reception, which can be determined by turning the equipment off and on, the user is encouraged to try to correct the interference by one or more of the following measures:

- Reorient or relocate the receiving antenna.
- Increase the separation between the equipment and receiver.
- Connect the equipment into an outlet on a circuit different from that to which the receiver is connected.
- Consult the dealer or an experienced radio/TV technician for help