

Prüfbericht-Nr.: <i>Test Report No.:</i>	50187794 001	Auftrags-Nr.: <i>Order No.:</i>	114081766	Seite 1 von 37 <i>Page 1 of 37</i>
Kunden-Referenz-Nr.: <i>Client Reference No.:</i>	N/A	Auftragsdatum: <i>Order date:</i>	03-Sep-2018	
Auftraggeber: <i>Client:</i>	WONDERCISE LIMITED 15/F LOCKHART CTR 301-307, LOCKHART RD WANCHAI, Hong Kong			
Prüfgegenstand: <i>Test item:</i>	Wondercise			
Bezeichnung / Typ-Nr.: <i>Identification / Type No.:</i>	WDC-012			
Auftrags-Inhalt: <i>Order content:</i>	FCC Part 15C / IC RSS-247 Test report (BLE)			
Prüfgrundlage: <i>Test specification:</i>	FCC 47CFR Part 15: Subpart C Section 15.247(DTS) RSS-247 (02-2017)			
Wareneingangsdatum: <i>Date of receipt:</i>	10-Sep-2018			
Prüfmuster-Nr.: <i>Test sample No.:</i>	A000805353-003 A000805353-004			
Prüfzeitraum: <i>Testing period:</i>	20-Sep-2018 – 28-Sep-2018			
Ort der Prüfung: <i>Place of testing:</i>	EMC/RF Laboratory Taipei			
Prüflaboratorium: <i>Testing laboratory:</i>	TUV Rheinland Taiwan Ltd.			
Prüfergebnis*: <i>Test result*:</i>	Pass			
Report date / tested by:		kontrolliert von / reviewed by:		
05-Oct-2018 Jack Chang/Project Manager		05-Oct-2018 Arvin Ho/Vice General Manager		
Datum <i>Date</i>	Name / Stellung <i>Name / Position</i>	Unterschrift <i>Signature</i>	Datum <i>Date</i>	Name / Stellung <i>Name / Position</i>
				Unterschrift <i>Signature</i>
Sonstiges / Other:				
Zustand des Prüfgegenstandes bei Anlieferung: <i>Condition of the test item at delivery:</i>		Prüfmuster vollständig und unbeschädigt <i>Test item complete and undamaged</i>		
* Legende:	1 = sehr gut P(ass) = entspricht o.g. Prüfgrundlage(n)	2 = gut F(ail) = entspricht nicht o.g. Prüfgrundlage(n)	3 = befriedigend N/A = nicht anwendbar	4 = ausreichend N/T = nicht getestet
Legend:	1 = very good P(ass) = passed a.m. test specification(s)	2 = good F(ail) = failed a.m. test specification(s)	3 = satisfactory N/A = not applicable	4 = sufficient N/T = not tested
<p>Dieser Prüfbericht bezieht sich nur auf das o.g. Prüfmuster und darf ohne Genehmigung der Prüfstelle nicht auszugsweise vervielfältigt werden. Dieser Bericht berechtigt nicht zur Verwendung eines Prüfzeichens. <i>This test report only relates to the a. m. test sample. Without permission of the test center this test report is not permitted to be duplicated in extracts. This test report does not entitle to carry any test mark.</i></p>				

TEST SUMMARY

5.1.1 ANTENNA REQUIREMENT

RESULT: *Passed*

5.1.2 PEAK OUTPUT POWER

RESULT: *Passed*

5.1.3 6dB BANDWIDTH AND 99% BANDWIDTH

RESULT: *Passed*

5.1.4 POWER DENSITY

RESULT: *Passed*

5.1.5 CONDUCTED SPURIOUS EMISSIONS AND FREQUENCY BAND EDGE MEASURED IN 100KHZ BANDWIDTH

RESULT: *Passed*

5.1.6 SPURIOUS EMISSION

RESULT: *Passed*

5.2.1 MAINS CONDUCTED EMISSIONS

RESULT: *Passed*

6.1.1 ELECTROMAGNETIC FIELDS

RESULT: *Passed*

Contents

1.	GENERAL REMARKS	5
1.1	COMPLEMENTARY MATERIALS.....	5
2.	TEST SITES	6
2.1	TEST LABORATORY	6
2.2	TEST FACILITY.....	6
2.3	LIST OF TEST AND MEASUREMENT INSTRUMENTS.....	7
2.4	TRACEABILITY	8
2.5	CALIBRATION	8
2.6	MEASUREMENT UNCERTAINTY	8
3.	GENERAL PRODUCT INFORMATION.....	9
3.1	PRODUCT FUNCTION AND INTENDED USE	9
3.2	SYSTEM DETAILS AND RATINGS.....	9
3.3	INDEPENDENT OPERATION MODES.....	10
3.4	NOISE GENERATING AND NOISE SUPPRESSING PARTS	10
3.5	SUBMITTED DOCUMENTS.....	10
4.	TEST SET-UP AND OPERATION MODES.....	11
4.1	PRINCIPLE OF CONFIGURATION SELECTION	11
4.2	TEST OPERATION AND TEST SOFTWARE.....	11
4.3	SPECIAL ACCESSORIES AND AUXILIARY EQUIPMENT	11
4.4	COUNTERMEASURES TO ACHIEVE EMC COMPLIANCE.....	12
4.5	TEST SETUP DIAGRAM	12
5.	TEST RESULTS	14
5.1	TRANSMITTER REQUIREMENT & TEST SUITES.....	14
5.1.1	<i>Antenna Requirement</i>	<i>14</i>
5.1.2	<i>Peak Output Power</i>	<i>15</i>
5.1.3	<i>6dB Bandwidth and 99% Bandwidth.....</i>	<i>16</i>
5.1.4	<i>Power Density</i>	<i>21</i>
5.1.5	<i>Conducted spurious emissions and Frequency Band Edge measured in 100kHz Bandwidth.....</i>	<i>24</i>
5.1.6	<i>Spurious Emission</i>	<i>28</i>
5.2	MAINS EMISSIONS.....	29
5.2.1	<i>Mains Conducted Emissions.....</i>	<i>29</i>
6.	SAFETY HUMAN EXPOSURE	30

6.1	RADIO FREQUENCY EXPOSURE COMPLIANCE	30
6.1.1	<i>Electromagnetic Fields.....</i>	<i>30</i>
7.	PHOTOGRAPHS OF THE TEST SET-UP.....	31
8.	LIST OF TABLES	37
9.	LIST OF PHOTOGRAPHS.....	37

1. General Remarks

1.1 Complementary Materials

The following attachments are integral parts of this test report:

Appendix P: Photo Documentation internal view
(File Name: 50187794 001 APPENDIXP)

Appendix D: Test Result of Radiated Emissions
(File Name: 50187794 001 APPENDIXD)

Test Specifications

The following standards were applied.

Table 1: Applied Standard and Test Levels

Radio
FCC 47CFR Part 15: Subpart C Section 15.247 FCC 47CFR Part 2: Subpart J Section 2.1091 RSS-247 Issue 2 (Feb 2017) RSS-102 Issue 5 RSS-Gen, Issue 5, April 2018 ANSI C63.10:2013 KDB558074 D01 DTS Meas Guidance v05 KDB447498 D01 General RF Exposure Guidance v06

2. Test Sites

2.1 Test Laboratory

TUV Rheinland Taiwan Ltd.
Taichung Branch Office

No.9, Lane 36, Minsheng Rd., Sec. 3, Daya District,
Taichung City 428
Taiwan (R.O.C.)

2.2 Test Facility

TUV Rheinland Taiwan Ltd.
Taipei Office

11F. No.758, Sec. 4, Bade Rd., Songshan Dist.
Taipei City 105
Taiwan (R.O.C.)

FCC RegistrationNo.: 340738
IC Canada Registration No.: 9465A-1
TAF Accredited NCC Test Lab. No.:0759
TAF ISO17025 Certification effective period: 2016-Jul-1st to 2019-Jun-30th



Testing Laboratory
0759

2.3 List of Test and Measurement Instruments

Table 2: List of Test and Measurement Equipment

Kind of Equipment	Manu-facturer	Type	S/N	Last Calibration	Next Calibration
Test Software	Farad	EZ_EMC	Ver. TUV3A1	N/A	N/A
EMI Test Receiver	R&S	ESCI 7	100797	2018/01/08	2019/01/08
Spectrum Analyzer	R&S	FSV 40	100921	2018/05/02	2019/05/02
Spectrum Analyzer	Agilent	N9010A	MY52221334	2018/02/05	2019/02/05
Preamplifier (30MHz -1GHz)	HP	8447F	2805A03335	2018/08/22	2019/08/22
Preamplifier (18 GHz -40 GHz)	COM-POWER	PAM-840	461257	2018/01/18	2019/01/18
Pre-Amplifier (1GHz~18GHz)	EM Electronics	EM01G18G	060558	2017/11/21	2018/11/21
Bilog Antenna	TESEQ	CBL6111D	29802	2018/08/22	2019/08/22
Horn Antenna	ETS-Lindgren	3117	00138160	2018/06/01	2019/06/01
Horn Antenna (18GHz~40GHz)	COM-POWER	AH-840	101029	2017/11/28	2018/11/28
Loop Antenna	Schwarzbeck	FMZB 1513	1513-076	2018/06/21	2019/06/21
Temp. & Humid. Chamber	Giant Force	GCT-099-40-S	MAF0103-007	2017/03/09	2019/03/09
LISN (1 phase)	R&S	ENV216	101243	2018/06/15	2019/06/15
LISN	R&S	ENV216	101262	2018/07/10	2019/07/10

2.4 Traceability

All measurement equipment calibrations are traceable to NML(Taiwan)/NIST(USA) or where calibration is performed outside Taiwan, to equivalent nationally recognized standards organizations.

2.5 Calibration

Equipment requiring calibration is calibrated periodically in a suitably accredited Calibration Lab. Additionally all equipment is verified for proper performance on a regular schedule using in house standards or comparisons.

2.6 Measurement Uncertainty

The estimated combined standard uncertainty for radiated emissions and conducted emissions measurements .

Table 3: Emission Measurement Uncertainty

Parameter	Uncertainty
Radio Frequency	$\pm 1 \times 10^{-7}$
RF power, conducted	± 1.5 dB
RF power density, conducted	± 3 dB
spurious emissions, conducted	± 3 dB
all emissions, radiated	± 6 dB
Temperature	± 1 °C
Humidity	± 5 %
DC and low frequency voltages	± 3 %

3. General Product Information

3.1 Product Function and Intended Use

The EUT is a SmartWatch. The Module has RF Shield and u.FL connector for External Antenna(s).

For details refer to the User Guide, Data Sheet and Circuit Diagram.

3.2 System Details and Ratings

Table 4: Basic Information of EUT

Item	EUT information
Kind of Equipment/Test Item	Wondercise
Type Designation	WDC-012
FCC ID	2AQIRWDC012
IC ID	24078-WDC012
HVIN	WDC012

Table 5: Technical Specification of EUT

Technical Specification	Value
Operating Frequencies	2402~2480MHz
Channel number	40
Operation Voltage	3.6V to 4.2V
Modulation	GFSK
Antenna gain	2.9338dBi

3.3 Independent Operation Modes

Basic operation modes are:

- A. Transmitting
 - 1. Low channel
 - 2. Middle channel
 - 3. High channel
- B. Receiving
- C. Standby
- D. Off

3.4 Noise Generating and Noise Suppressing Parts

Refer to the Circuit Diagram.

3.5 Submitted Documents

- Circuit Diagram
- Blocking Diagram
- Rating Label
- Technical Description

4. Test Set-up and Operation Modes

4.1 Principle of Configuration Selection

The equipment under test (EUT) was configured to measure its maximum power level. The test modes were adapted accordingly in reference to the instructions for use.

4.2 Test Operation and Test Software

Setup for testing: Test samples are provided with a UART-USB interface which makes it possible to control them through the test software installed on a notebook computer.

This software was running on the laptop computer connected to the EUT. It was used to enable the operation modes listed in section 3.3 as appropriate.

The samples were used as follows:

Conducted: A000805353-003

Radiation: A000805353-004

Full test was applied on all test modes, but only worst case was shown

BLE mode:

Channel Low (2402MHz), Channel Mid (2440MHz) and Channel High (2480MHz) were chosen for full testing.

4.3 Special Accessories and Auxiliary Equipment

The product has been tested together with the following additional accessories:

Description	Manufacturer	Model No.	Serial No.
Notebook(EMC-06)	Lenovo	TP00048A	PB-0F8B2
Test tool	TI	SmartRF Studio 7	v.2.6.0

4.4 Countermeasures to achieve EMC Compliance

The test sample which has been tested contained the noise suppression parts as described in the Constructional Data Form or the Technical Construction File. No additional measures were employed to achieve compliance.

4.5 Test Setup Diagram

Diagram of Measurement Configuration for Radiation Test

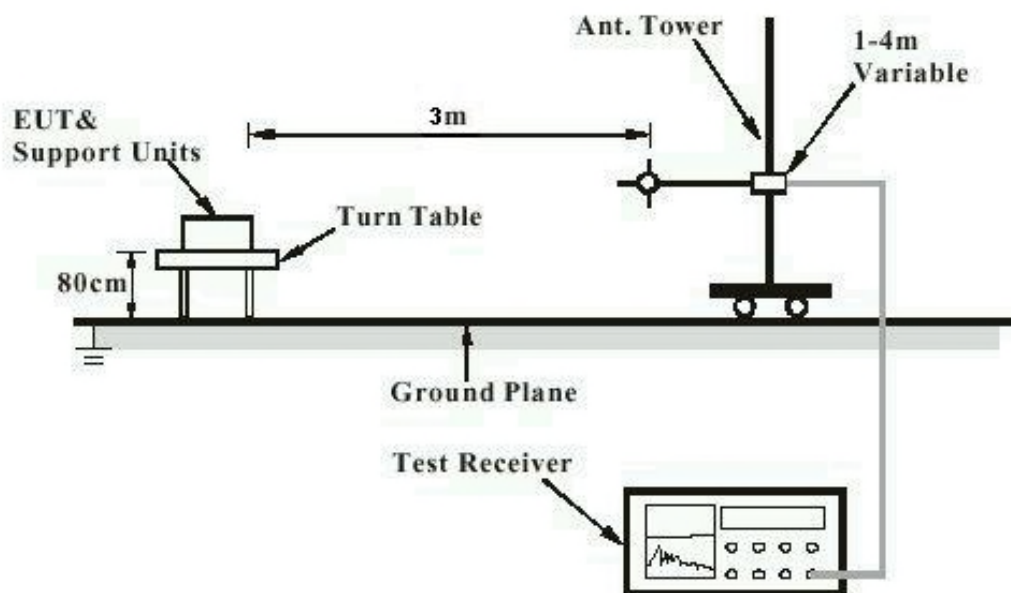

Note: Measurements above 1 GHz are done with a table height of 1.5m

Diagram of Measurement Equipment Configuration for Mains Conduction Measurement (if applicable)

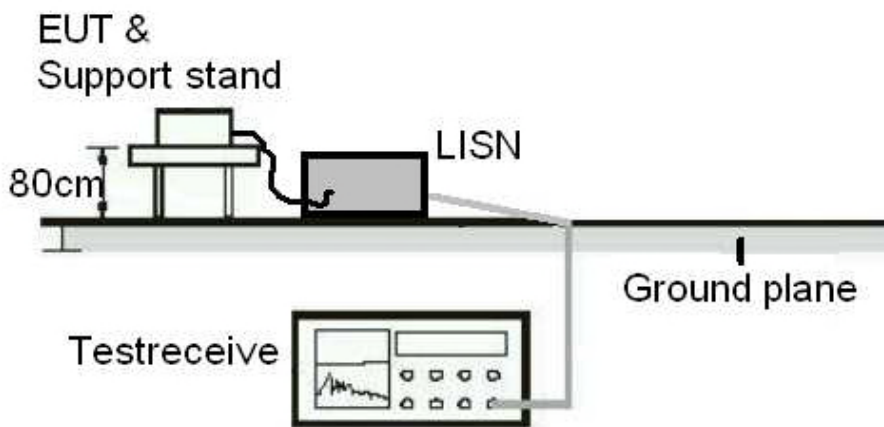
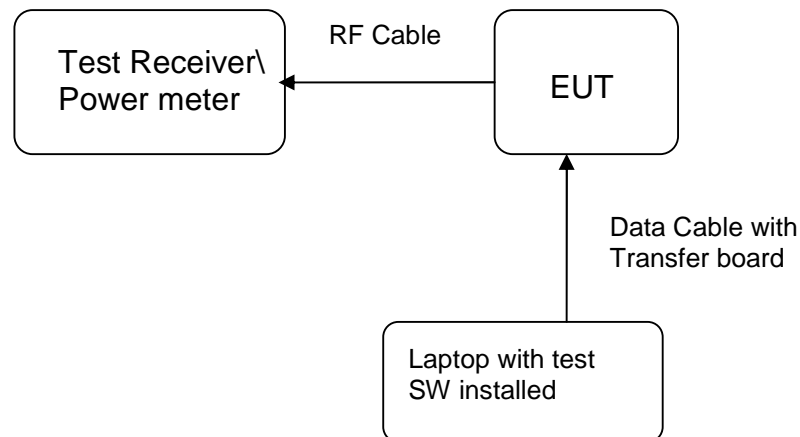

Diagram of Measurement Equipment Configuration for Conducted Transmitter Measurement



5. Test Results

5.1 Transmitter Requirement & Test Suites

5.1.1 Antenna Requirement

RESULT: **Passed**

Test standard	:	LP0002(2016): 2.2, 3.10.1, (3) FCC Part 15.247(b)(4), Part 15.203 and RSS- Gen 8.3
Requirement	:	use of approved antennas only with directional gains that do not exceed 6 dBi

According to the manufacturer declaration, the EUT has an antenna with Max directional gain of 2.9338dBi. The antenna a FPC antenna with no possibility of replacement with a non-approved antenna by the end-user. Therefore, the EUT is considered to comply with this provision.

Refer to EUT photo for details.

5.1.2 Peak Output Power

RESULT:
Passed

Test standard : LP0002(2016): 3.10.1, (2)
 FCC Part 15.247(b)(3), RSS-247 5.4(4)
 Basic standard : ANSI C63.10:2013, KDB558074
 Limit : 1 Watt
 Kind of test site : Shielded room

Test setup

Test Channel : Low/ Middle/ High
 Operation Mode : A
 Ambient temperature : 20-24 °C
 Relative humidity : 50-65 %
 Atmospheric pressure : 100-103 kPa

Table 6: Test result of Peak Output Power

Channel	Channel Frequency (MHz)	Output Power		Limit
		(dBm)	(W)	(W)
Low Channel	2402	0.82	0.001208	1
Middle Channel	2440	-0.01	0.000998	1
High Channel	2480	-0.85	0.000822	1

Pmax: 0.82dBm, 1.21mW

5.1.3 6dB Bandwidth and 99% Bandwidth

RESULT:
Passed

Test standard : LP0002(2016): 3.10.1, (5)
 FCC Part 15.247(a)(2), RSS-247 5.2(1)
 RSS-Gen (Issue 5)
 Basic standard : ANSI C63.10:2013, KDB558074
 Kind of test site : Shielded room

Test setup

Test Channel : Low/ Middle/ High
 Operation Mode : A
 Ambient temperature : 20-24°C
 Relative humidity : 50-65%
 Atmospheric pressure : 100-103 kPa

Table 7: Test result of 6dB Bandwidth

Channel	Channel Frequency (MHz)	6dB Bandwidth (kHz)	Limit (kHz)	Result
Low Channel	2402	701.8	>500	Pass
Mid Channel	2440	711.5	>500	Pass
High Channel	2480	713.4	>500	Pass

Table 8: Test result of 99% Bandwidth,

Channel	Channel Frequency (MHz)	99% Bandwidth (MHz)
Low Channel	2402	1.0456
Mid Channel	2440	1.0528
High Channel	2480	1.0478

Test Plot of 6dB Bandwidth

Low Channel

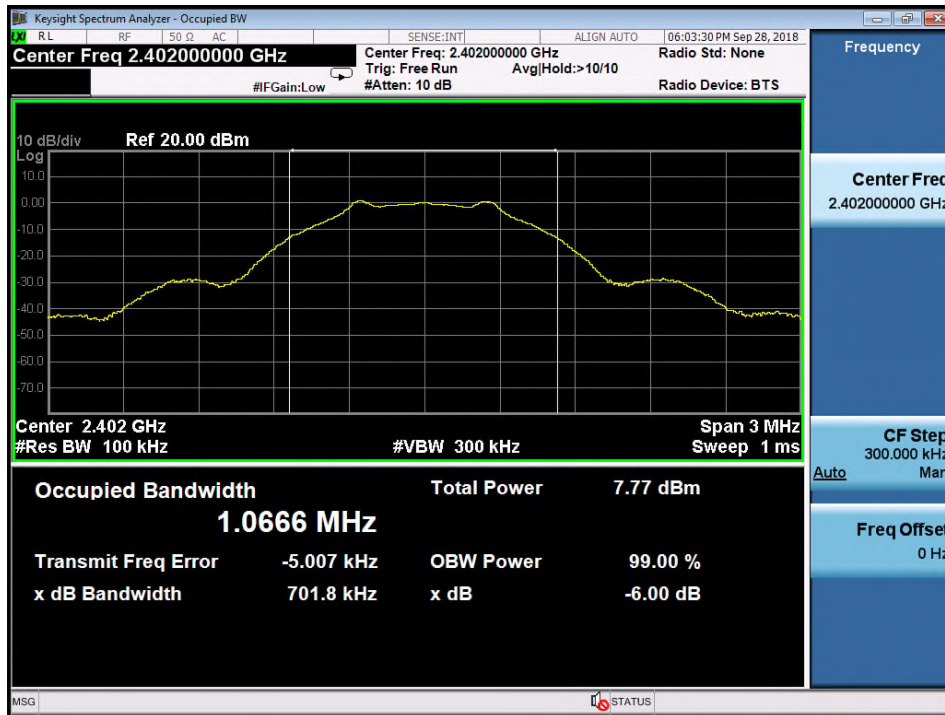

Middle Channel

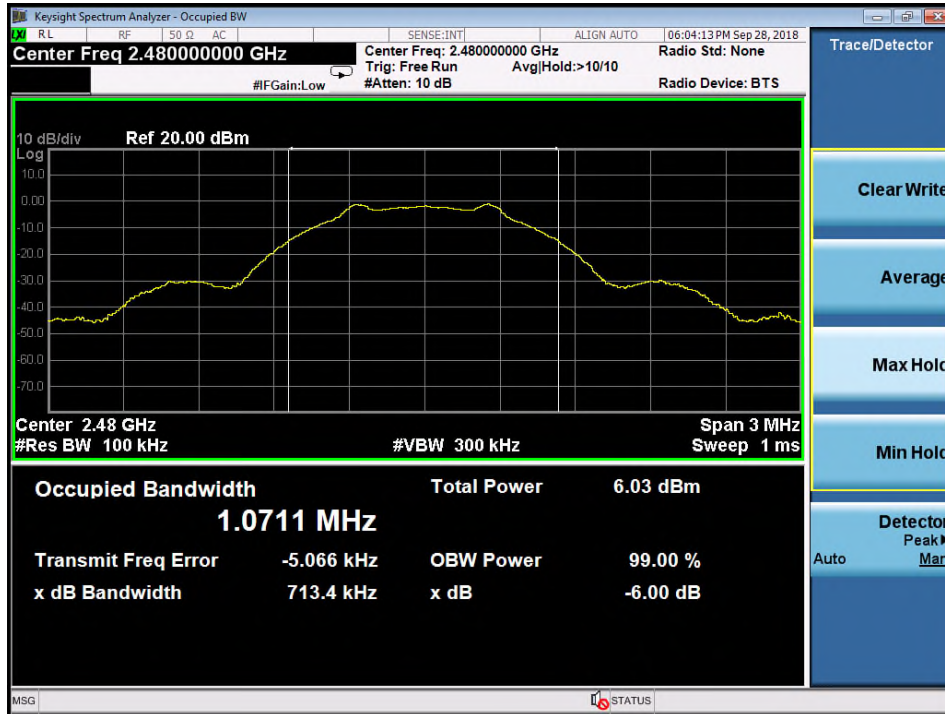

High Channel

Test Plot of 99% Bandwidth

Low Channel

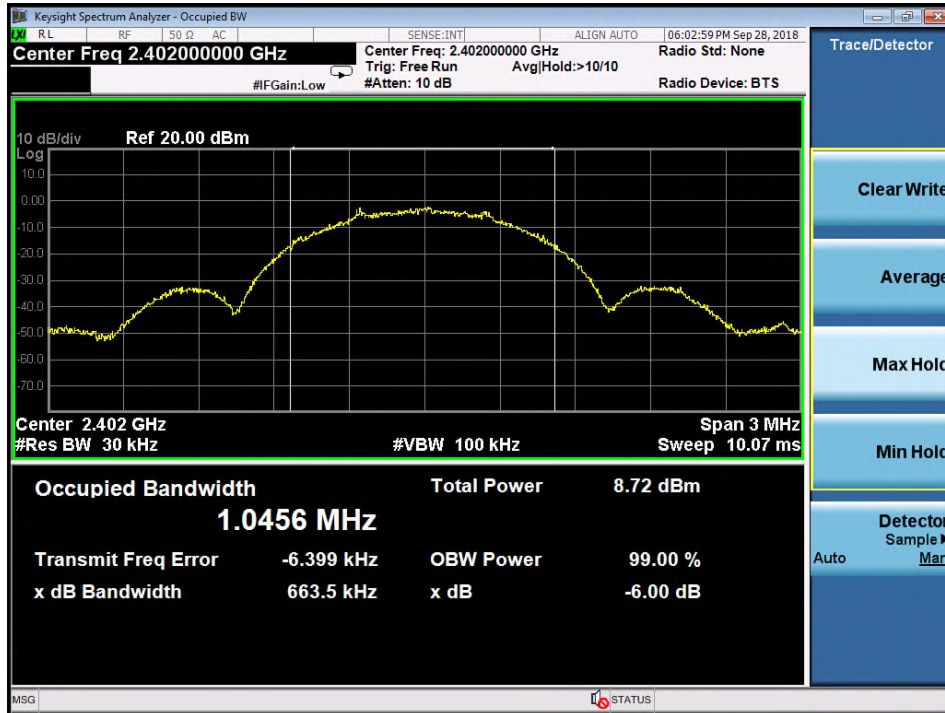

Middle Channel

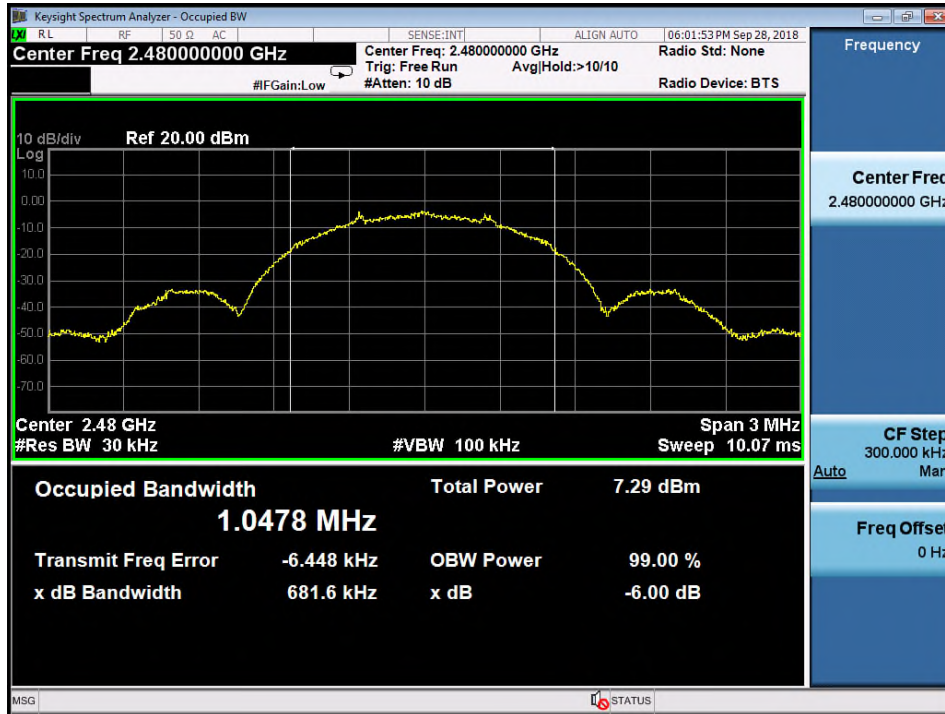

High Channel

5.1.4 Power Density

RESULT:
Passed

Test standard : LP0002(2016): 3.10.1, (6.2.2)
 FCC Part 15.247(e) , RSS-247 5.2(2)
 Basic standard : ANSI C63.10:2013, KDB558074
 Kind of test site : Shielded room

Test setup

Test Channel : Low/ Middle/ High
 Operation Mode : A
 Ambient temperature : 20-24°C
 Relative humidity : 50-65%
 Atmospheric pressure : 100-103 kPa

Table 9: Test result of Power Density

Channel	Channel Frequency (MHz)	Power Density	Limit
		(dBm)	(dBm)
Low Channel	2402	-9.28	8
Middle Channel	2440	-8.08	8
High Channel	2480	-9.71	8

Test Plot of Power Density

Low Channel

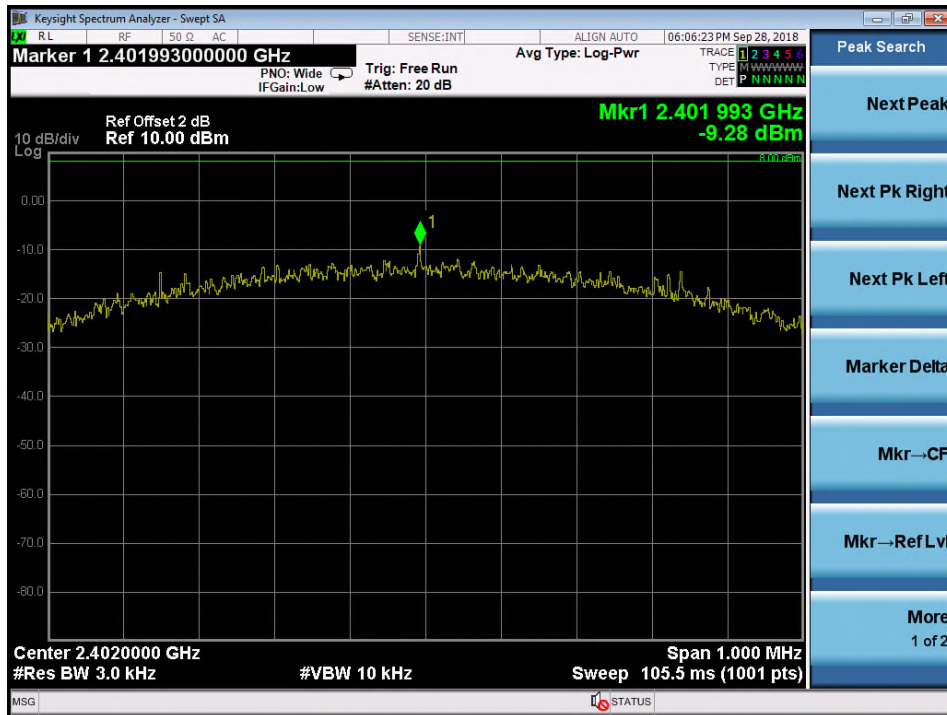

Middle Channel

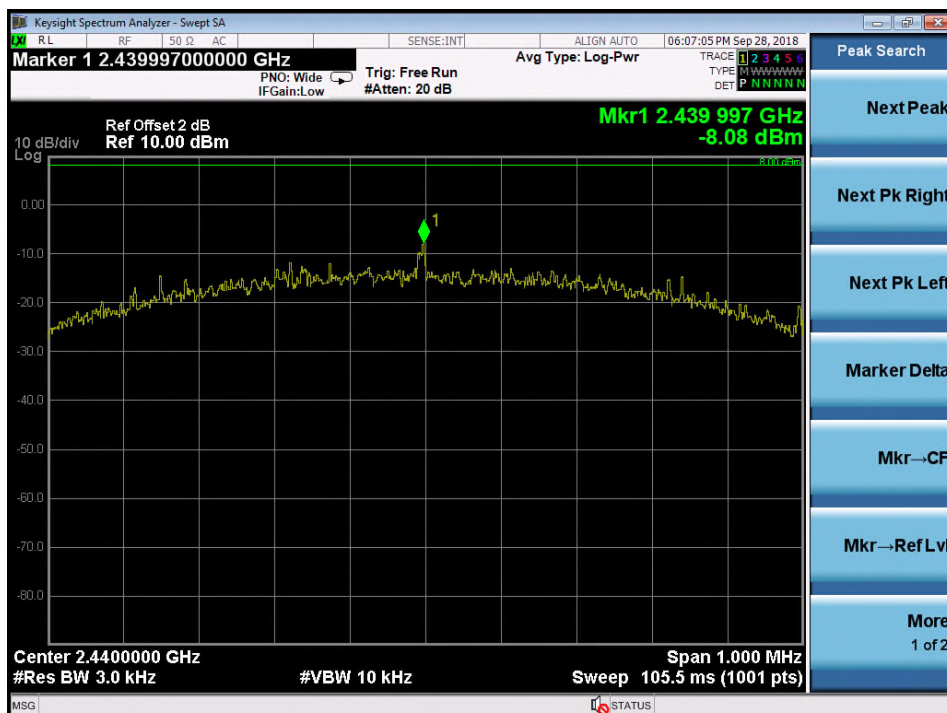

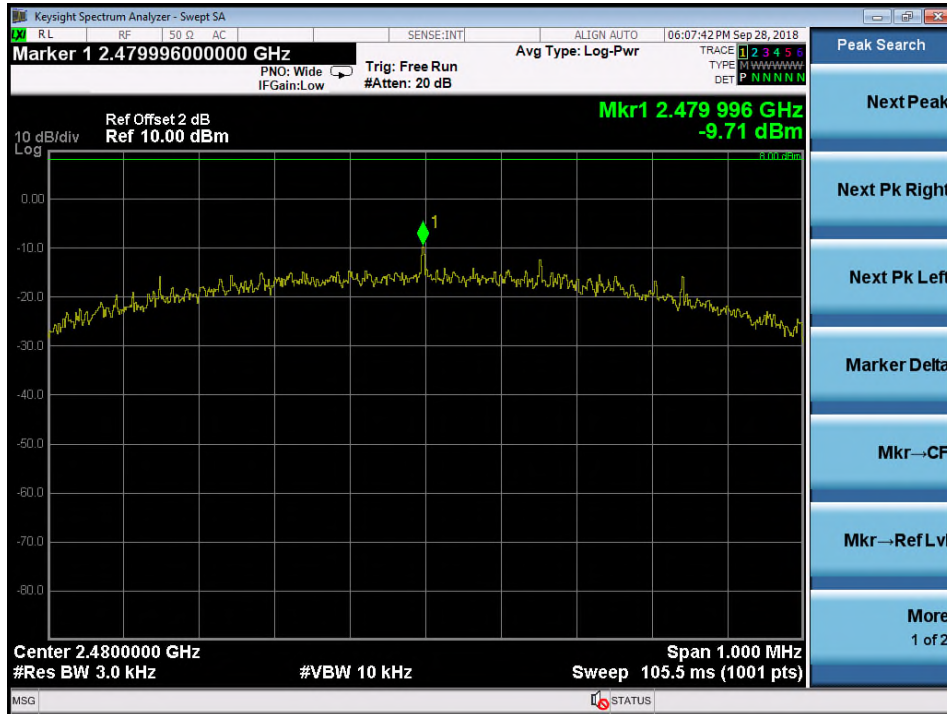
High Channel

5.1.5 Conducted spurious emissions and Frequency Band Edge measured in 100kHz Bandwidth

RESULT: **Passed**

Test standard : LP0002(2016): 3.10.1, (5)
FCC part 15.247(d), RSS-247 5.5
Basic standard : ANSI C63.10:2013, KDB558074
Limit : 20dB (below that in the 100kHz bandwidth within the
band that contains the highest level of the desired power)
Kind of test site : Shielded room

Test setup

Test Channel : Low/ Mid/ High for spurious, Low/ High for
Band Edge
Operation mode : A
Ambient temperature : 20-24°C
Relative humidity : 50-65%
Atmospheric pressure : 100-103 kPa

All emissions are more than 20dB below fundamental, details refer to following test plot, and compliance is achieved as well.

Due to the small size of the product and that there are no inductive components of significant size, 9kHz to 30MHz frequency range is not tested based on technical judgment.

Test Plot 100kHz Conducted Emissions

Low Channel



Middle Channel



High Channel

Test Plot 100kHz RBW of Band Edge

Low Channel

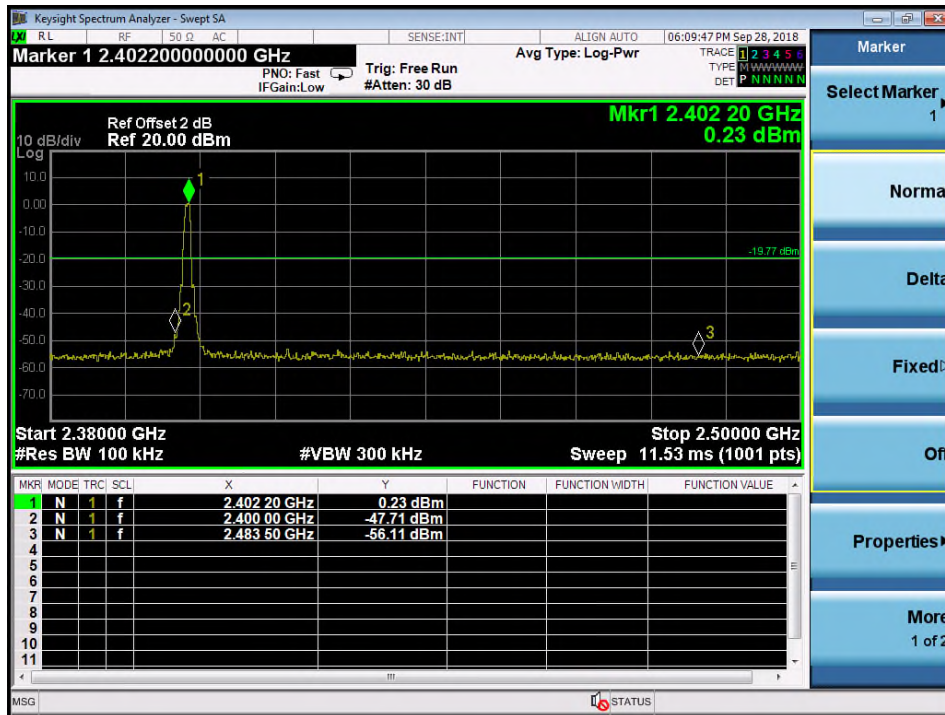

High Channel

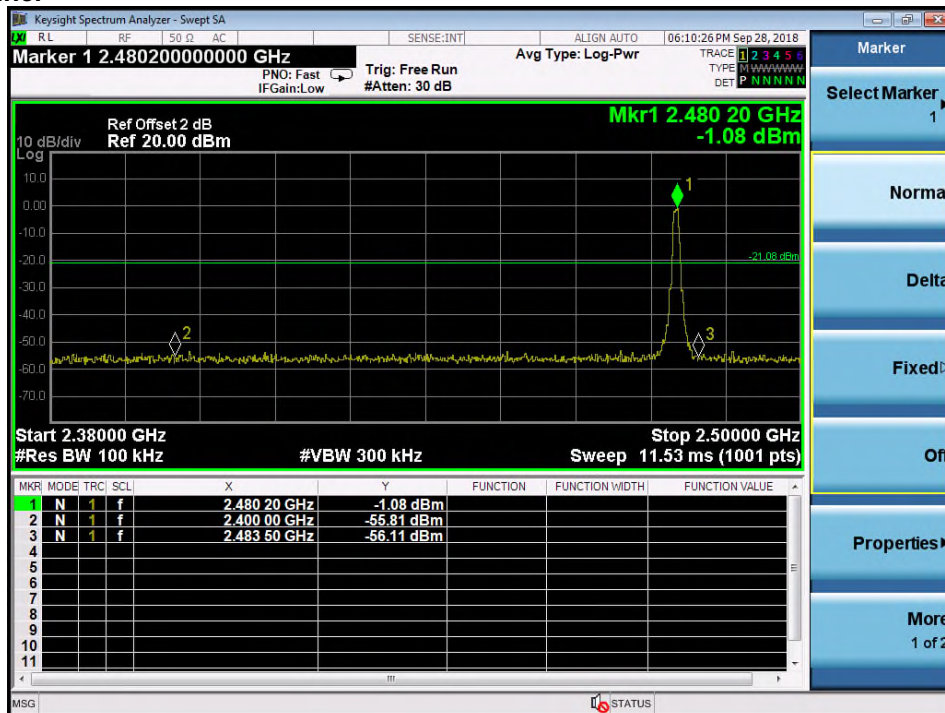

5.1.6 Spurious Emission

RESULT:**Passed**

Test standard	:	FCC part 15.247(d), FCC 15.205, FCC 15.209, RSS-247 5.5 and RSS-Gen 8.9 LP0002(2016): 3.10.1, (5)
Basic standard	:	ANSI C63.10: 2013
Limits	:	Radiated emissions which fall in the restricted bands, as defined in FCC 15.205(a) and RSS-Gen i5, 8.10 (Table 7), must comply with the radiated emission limits specified in FCC 15.209(a) and RSS-Gen i5, 8.9 (Table 5 and 6). Radiated emissions which fall in the restricted bands, as defined in LP0002(2016): 2.7 , must comply with the radiated emission limits specified in LP0002(2016): 2.8 Emission radiated outside the specified frequency bands must comply with the radiated emission limits specified in FCC 15.209(a) and FCC 15.249(a), RSS-Gen i5, 8.9 (Table 5 and 6). Emission radiated outside the specified frequency bands must comply with the radiated emission limits specified in LP0002(2016): 2.8
Kind of test site	:	3m Semi-Anechoic Chamber

Test setup

Test Channel	:	Low/ Middle/ High
Operation mode	:	A, B

For details refer to Appendix D.

The Radiated Emissions testing was performed in the X, Y and Z axis orientation. The worst-case Axis orientation is recorded in this test report.

5.2 Mains Emissions

5.2.1 Mains Conducted Emissions

RESULT:**Passed**

Test standard : FCC Part 15.207
FCC Part 15.107
RSS-Gen 8.8
LP0002: 2.3

Limits : Mains Conducted emissions as defined in
above test standards must comply with the
mains conducted emission limits specified

Kind of test site : Shielded Room

Test setup

Test Channel : Middle
Operation mode : A

Remark: For details refer to Appendix D.

6. Safety Human exposure

6.1 Radio Frequency Exposure Compliance

6.1.1 Electromagnetic Fields

RESULT:**Passed**

Test standard : FCC KDB Publication 447498 D01 v06
47CFR 1.1310
47CFR 2.1091
RSS-102 issue 5

FCC:

Therefore the maximum output power of the transmitter is $1.21\text{mW} < 10\text{mW}$ (Distance: 5 mm), hence the EUT is excluded from SAR evaluation according to FCC KDB publication 447498 D01: Mobile Portable RF Exposure.

Canada:

Maximum conducted peak power: 1.21 mW
Antenna Gain: 2.9338 dbi
Maximum EIRP available 2.37 mW

Since maximum output power of the transmitter is $2.37\text{mW} < 10\text{mW}$ (distance ≤ 5 mm), hence the EUT is excluded from SAR evaluation according to Table 1 in RSS-102, For limb-worn devices where the 10 gram value applies, the exemption limits for routine evaluation in Table 1 of RSS-102 are multiplied by a factor of 2.5.

---End---

7. Photographs of the Test Set-Up

Photograph 1: Set-up for Spurious Emissions (Front View 1)



Photograph 2: Set-up for Spurious Emissions (Front View 2)



Photograph 3: Set-up for Spurious Emissions (Back View 1)

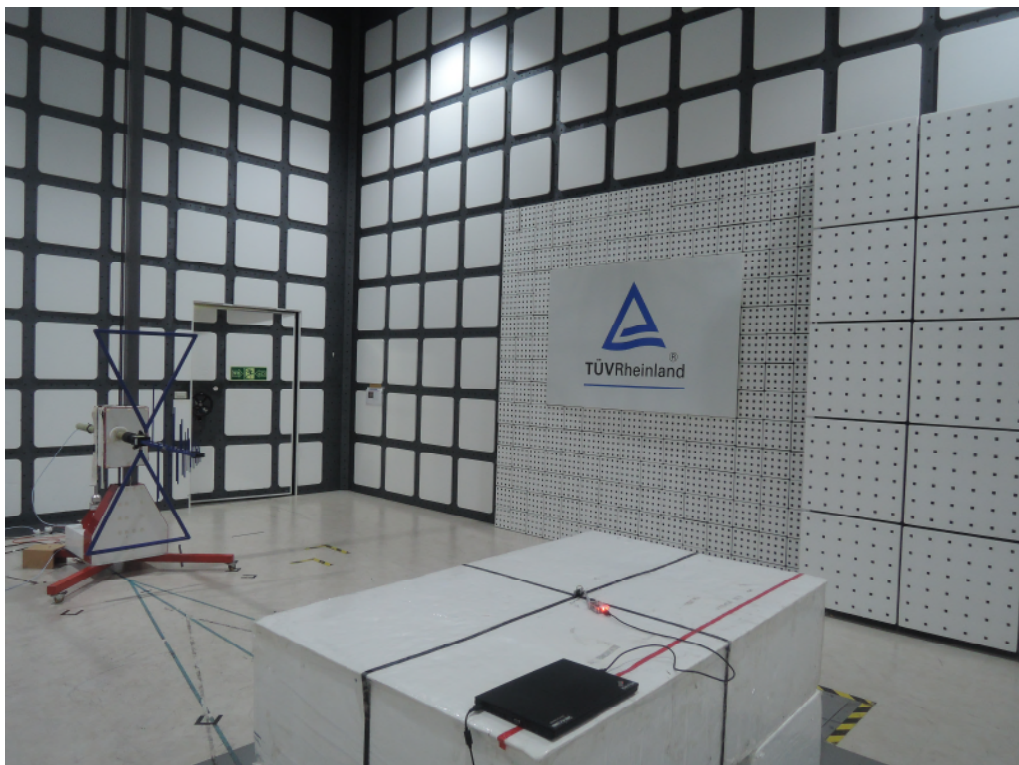

Photograph 4: Set-up for Spurious Emissions (Back View 2)

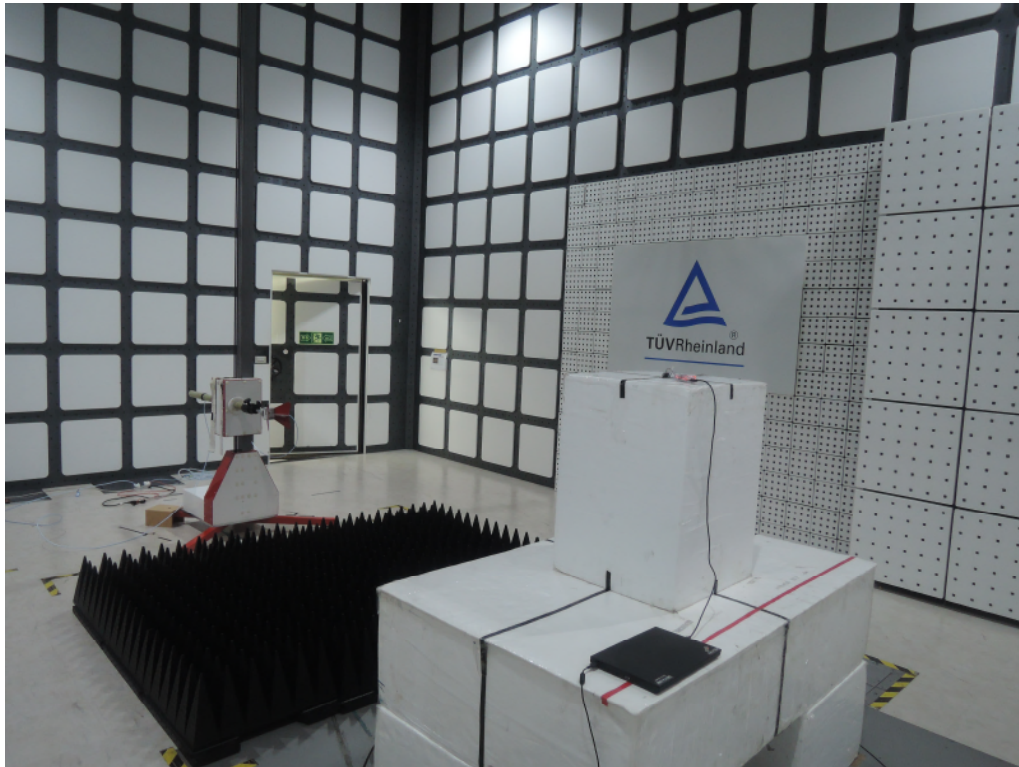

Photograph 5: Set-up for Spurious Emissions (Back View 3)



Photograph 6: Set-up for Spurious Emissions (Back View 4)

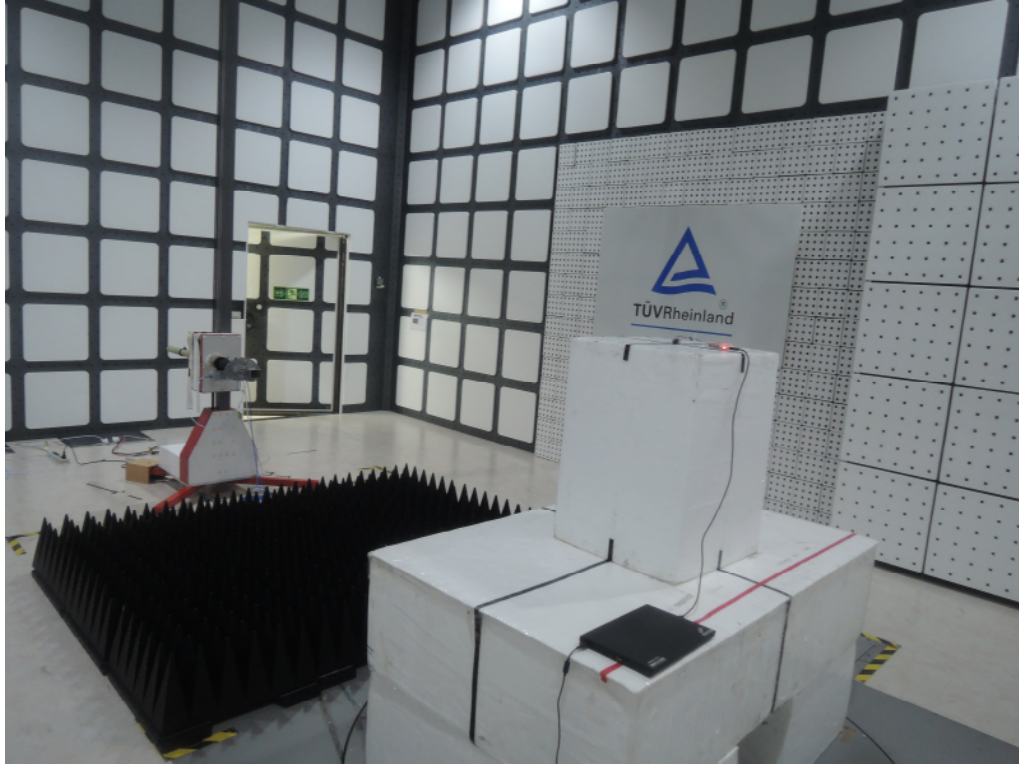

Photograph 7: Set-up for Conducted testing

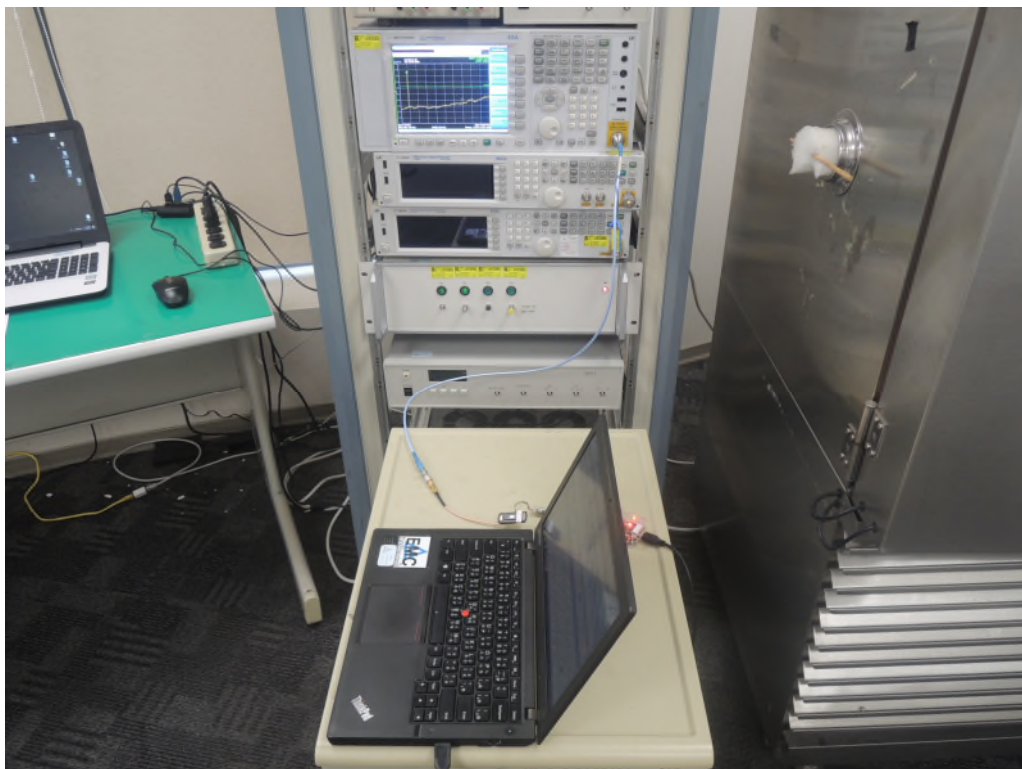

Photograph 8: Set-up for Conducted testing

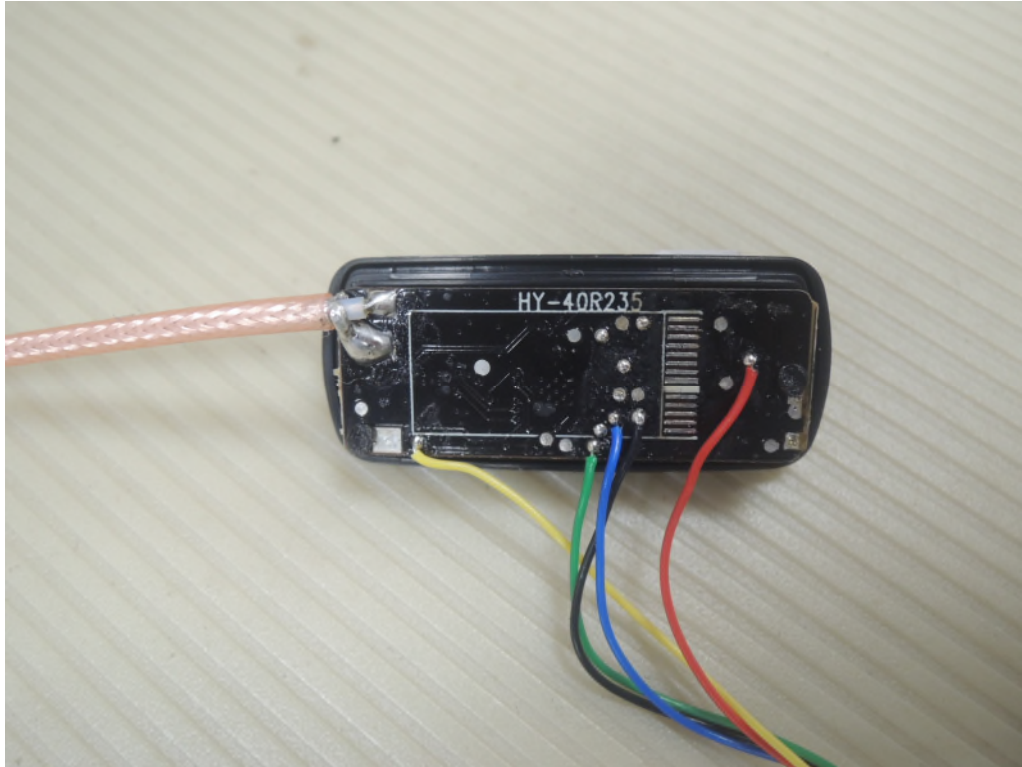

Photograph 9: Set-up for Mains Conducted testing Front



Photograph 10: Set-up for Mains Conducted testing Back

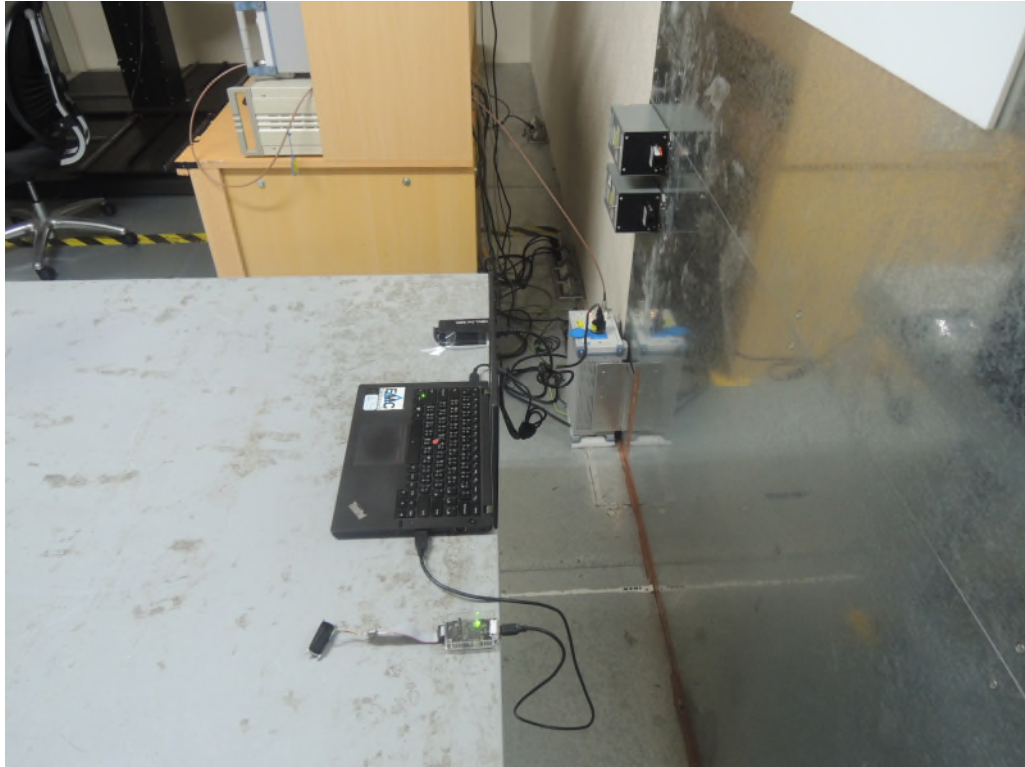

8. List of Tables

Table 1: Applied Standard and Test Levels	5
Table 2: List of Test and Measurement Equipment	7
Table 3: Emission Measurement Uncertainty.....	8
Table 4: Basic Information of EUT	9
Table 5: Technical Specification of EUT	9
Table 6: Test result of Peak Output Power	15
Table 7: Test result of 6dB Bandwidth	16
Table 8: Test result of 99% Bandwidth,.....	16
Table 9: Test result of Power Density	21

9. List of Photographs

Photograph 1: Set-up for Spurious Emissions (Front View 1).....	31
Photograph 2: Set-up for Spurious Emissions (Front View 2).....	32
Photograph 3: Set-up for Spurious Emissions (Back View 1).....	32
Photograph 4: Set-up for Spurious Emissions (Back View 2).....	33
Photograph 5: Set-up for Spurious Emissions (Back View 3).....	33
Photograph 6: Set-up for Spurious Emissions (Back View 4).....	34
Photograph 7: Set-up for Conducted testing	34
Photograph 8: Set-up for Conducted testing	35
Photograph 9: Set-up for Mains Conducted testing Front.....	35
Photograph 10: Set-up for Mains Conducted testing Back	36