

# Specification For Approval Earphone

Manufacturer: SHENZHEN ZHIZE TECHNOLOGY CO., LTD.

Address: No. 13, Baoke Industrial Park, Langkou Community, Dalang Street, Longhua District, Shenzhen, China

Model Name: SG-A11-6. 3UH

We statement that All measurements were performed radiated and therefore additional antenna gain documentation is not required.

## Coil Dimensions

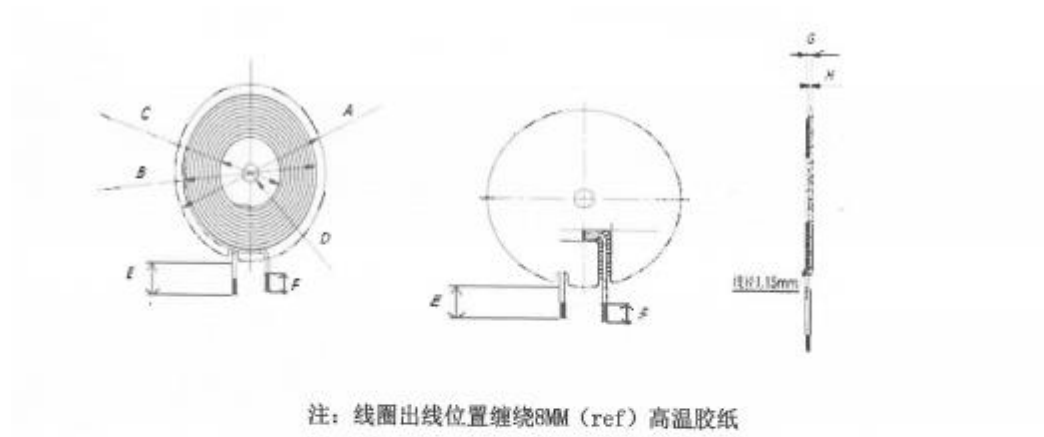

标准	A	B	C	D	E	F	G	H	
STD	50.0±1	42.5±1.5	20.5±1.5	5±0.5	20±2	2-5	2.6Max	1.0±0.15	

# Specification For Approval Watch

Manufacturer: Shenzhen Shengguang Electronic Technology Co., LTD

Address: 1165 Guanguan Road, Guanlan Street, Longhua District, Shenzhen, China

Model Name: Coil G50 6.3UH

We statement that All measurements were performed radiated and therefore additional antenna gain documentation is not required.

## Coil Dimensions

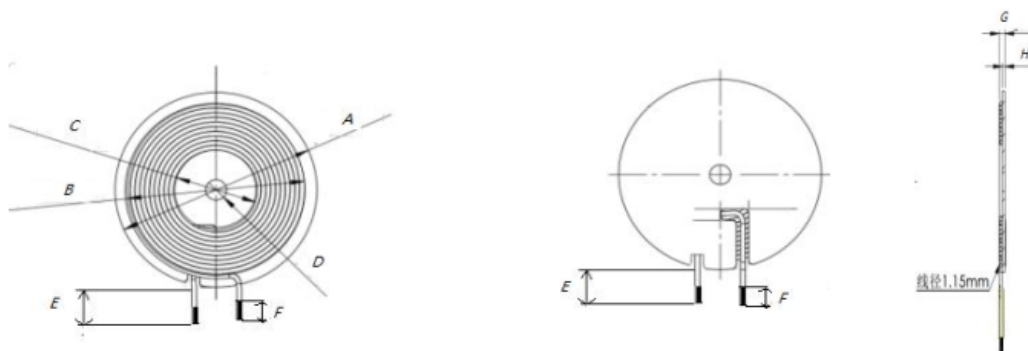

Note: Wrap 6MM (Min) high-temperature adhesive tape around the coil outlet position

STD	A	B	C	D	E	F	G	H	
STD	50.0 ± 1	42.5 ± 1.5	20.5 ± 1.5	5 ± 0.5	20 ± 2	2-5	2.6Max	1.0 ± 0.15	

# Specification For Approval Phone

Manufacturer: Shenzhen Shengguang Electronic Technology Co., LTD

Address: 1165 Guanguan Road, Guanlan Street, Longhua District, Shenzhen, China

Model Name: 4.0UH-9TS

We statement that All measurements were performed radiated and therefore additional antenna gain documentation is not required.

## Coil Dimensions

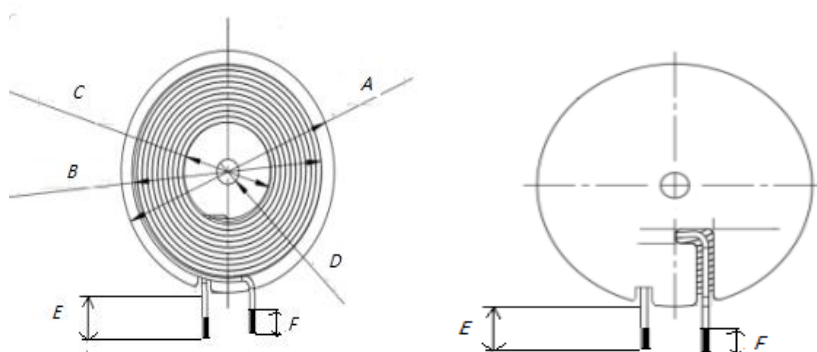

STD	A	B	C	D	E	F
STD	$25 \pm 1$	$21 \pm 1.5$	$15 \pm 1.5$	$8 \pm 0.5$	$4 \pm 1$	2-1