

# User Manual

Govee Smart Humidifier

# Table of Contents

<b>Safety Instructions</b>	<b>01</b>
<b>Package Includes</b>	<b>03</b>
<b>Specifications</b>	<b>03</b>
<b>Getting to Know Your Smart Humidifier</b>	<b>03</b>
<b>Operate the Humidifier</b>	<b>05</b>
<b>Getting Started</b>	<b>07</b>
<b>Using Your Smart Humidifier</b>	<b>10</b>
<b>Pairing Your Smart Humidifier with Govee Home App</b>	<b>11</b>
<b>Using the Aroma Box</b>	<b>12</b>
<b>Care &amp; Maintenance</b>	<b>13</b>
<b>Descaling the Humidifier</b>	<b>14</b>
<b>Cleaning the Aroma Pad</b>	<b>16</b>
<b>Troubleshooting</b>	<b>17</b>

# READ AND SAVE THESE INSTRUCTIONS

## Safety Instructions

### General Safety

- Only use the humidifier as described in this manual.
- When not in use for an extended period, turn the humidifier off and disconnect the plug from the outlet.
- Do not use the humidifier in wet environments.
- Keep the humidifier out of reach from children.
- Do not attempt to disassemble the humidifier or its components.
- Always unplug the humidifier from power before cleaning it or detaching the water tank from the humidifier base.
- Always place the humidifier on a flat, horizontal surface before using.
- Only fill the water tank with clean water. Never fill the water tank with any other liquids.
- Do not place the humidifier near heat sources such as stovetops, ovens, or radiators.
- Do not place the humidifier directly on carpets or rugs.
- Do not use non-Govee humidifier parts as replacement parts for this product.
- Do not cover the nozzle while the humidifier is on, as this may damage the humidifier.
- Remove the water tank from the base before moving the humidifier.
- Do not immerse the humidifier base, power cord, or power plug in water.
- If the humidifier is damaged or is not functioning properly, stop using it and contact Customer Support immediately.
- Not for commercial use. Household use only.
- To reduce the risk of fire, electric shock, or other injury, always follow all instructions and safety guidelines.

### Power Cord & Plug

- Ensure that the plug fits properly into a polarized outlet.
- Do not handle the power cord or plug with wet hands. Keep the power cord and plug away from liquids.
- Your humidifier has a polarized plug (one prong is wider than the other), which fits into a polarized outlet in only one orientation. This is a safety feature to reduce the risk of electric shock. If the plug does not fit, reverse the plug to the correct orientation. If it still does not fit, do not bypass this safety feature and try forcing the plug into the outlet; instead, do not use it with the outlet.

### Risk of Leaks and Electric Shock

- Do not add essential oils, supplemental water treatment liquids, or water filters into the water tank or base chamber, as this may damage the humidifier and cause leaks.
- Only add essential oils to the aroma pad.

# LIRE ET CONSERVER CES INSTRUCTIONS

## La consignes de sécurité

### La sécurité générale

- Utilisez l'humidificateur seulement comme décrit dans ce manuel.
- Lorsqu'il n'est pas utilisé pendant une période prolongée, éteignez l'humidificateur et débranchez la fiche de la prise.
- N'utilisez pas l'humidificateur dans des environnements humides.
- Gardez l'humidificateur hors de la portée des enfants.
- N'essayez pas de démonter l'humidificateur ou ses composants.
- Débranchez toujours l'humidificateur du secteur avant de le nettoyer ou de détacher le réservoir d'eau de la base de l'humidificateur.
- Placez toujours l'humidificateur sur une surface plat et horizontale avant de l'utiliser.
- Ne remplissez le réservoir d'eau qu'avec de l'eau propre. Ne remplissez jamais le réservoir d'eau avec d'autres liquides.
- Ne placez pas l'humidificateur à proximité de sources de chaleur telles que des fourneaux de cuisine, des fours ou des radiateurs.
- Ne placez pas l'humidificateur directement sur des tapis ou des moquettes.
- N'utilisez pas de pièces d'humidificateur autres que Govee comme pièces de rechange pour ce produit.
- Ne couvrez pas la buse lorsque l'humidificateur est allumé, car cela pourrait endommager l'humidificateur.
- Retirez le réservoir d'eau de la base avant de déplacer l'humidificateur.
- N'immergez pas la base de l'humidificateur, le cordon d'alimentation ou la fiche dans l'eau. Si l'humidificateur est endommagé ou ne fonctionne pas correctement, arrêtez de l'utiliser et contactez immédiatement le service client
- Pas pour un usage commercial. Usage domestique uniquement.
- Pour réduire le risque d'incendie, de choc électrique ou d'autres blessures, suivez toujours toutes les instructions et consignes de sécurité.

### Le cordon d'alimentation & la fiche

- Assurez-vous que la fiche s'insère correctement dans une prise polarisée.
- Ne manipulez pas le cordon d'alimentation ou la fiche avec les mains mouillées. Gardez le cordon d'alimentation et la fiche à l'écart des liquides.
- Votre humidificateur a une fiche polarisée (une broche est plus large que l'autre), qui s'insère dans une prise polarisée dans un seul sens. Il s'agit d'une fonction de sécurité pour réduire le risque de choc électrique. Si la fiche ne rentre pas, inversez la fiche dans le bon sens. S'il ne rentre toujours pas, ne contournez pas cette fonction de sécurité et essayez de forcer la fiche dans la prise. Au lieu de cela, ne l'utilisez pas avec la prise.

### Le risque de fuites et de choc électrique

- N'ajoutez pas d'huiles essentielles, de liquides de traitement d'eau supplémentaires ou de filtres à eau dans le réservoir d'eau ou la chambre de base. Cela pourrait endommager l'humidificateur et provoquer des fuites.
- N'ajoutez que des huiles essentielles au coussin aromatique.

# Package Includes

Item	Quantity
Smart Humidifier	1
Cleaning Brush	1
Aroma Pads (1 Pre-Installed)	3
Quick Start Guide	1
User Manual	1

# Specifications

Power Supply	AC 120V, 60Hz
Rated Power	26W
Water Tank Capacity	1.5gal/6L
Max Run Time (low mist setting)	60 Hours <b>Note:</b> The humidifier may run for a longer or shorter time depending on the environmental temperature and humidity.
Noise Level	≤30dB
Effective Range	≤602ft <sup>2</sup> /56 m <sup>2</sup>
Dimensions	7.28X7.28X18.27 inch/ 18.5X18.5X46.4cm
Weight	5.07lb/2.3kg

# Getting to Know Your Smart Humidifier

- a. Mist Nozzle
- b. Water Tank Cover
- c. Handle
- d. Mist Tube
- e. Max Water Line
- f. Water Tank
- g. Water Outlet Valve
- h. Cleaning Brush
- i. UVC Light
- j. Float
- k. Baffle
- l. Air Outlet
- m. Transducer
- n. Aroma Box
- o. Aroma Pad
- p. Power Cord
- q. Air Inlet
- r. Non-slip Pad
- s. Night Light

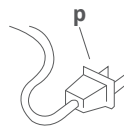
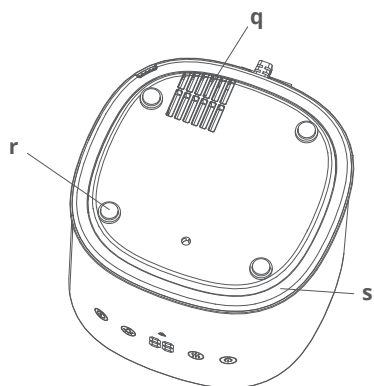
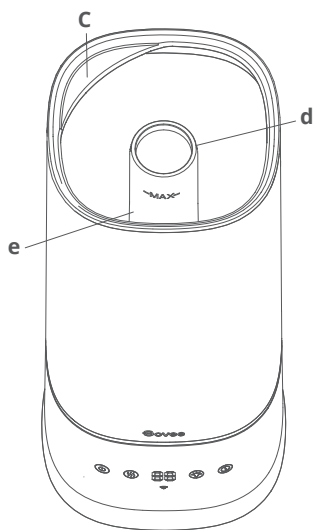
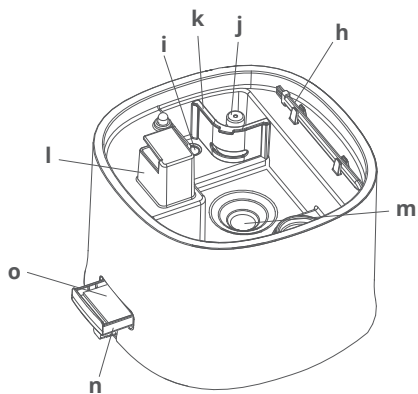
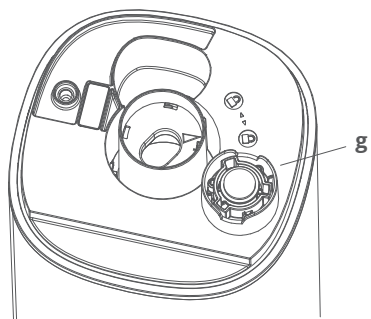
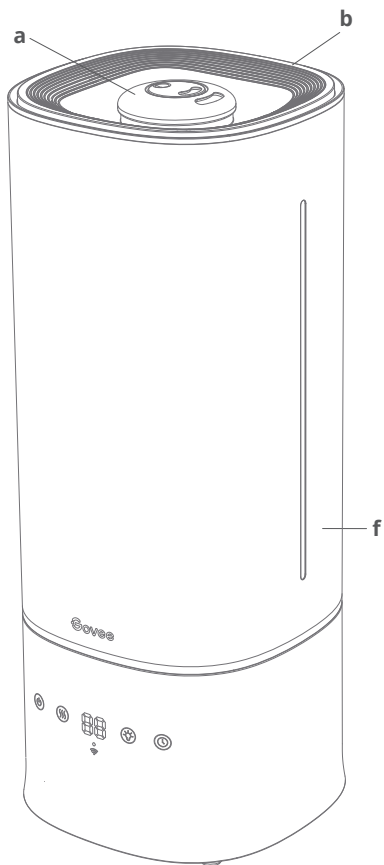

# Operate the Humidifier

Besides the on-device buttons, Govee Home App can also be used to control the below functions (as well as other app functions).

## 1.Controls



### Power Button

Press to power on the humidifier.

**Note:** When the humidifier is powered off, its fan will continue spinning for 15 seconds to clear away internal mist to avoid water vapor accumulation that may affect the life of the humidifier.



### Mist Level Button

Press repeatedly to cycle through mist settings: Auto Mode, Mist Level 1, Mist Level 2, Mist Level 3.

**Note:** The default target ambient humidity of Auto Mode is 60% when the humidifier is not connected to Govee Home App.

You can set the target humidity for Auto Mode via Govee Home App.

The Custom Mode can only be set and activated via Govee Home App and not directly on the humidifier.



### Night Light Button

Press to turn on the night light.

**Note:** The brightness and color of the night light can be adjusted via Govee Home App.



### Timer Button

Press repeatedly to select a timer for the humidifier.

## 2. Display & LED Indicators

On-Device Display		
Button	Display	Status
Mist Level Button	AU	Auto Mode
	01	Mist Level 1
	02	Mist Level 2
	03	Mist Level 3
Timer Button	01-24	Length of Timer Setting
	Humidity Level	Current Humidity
Wi-Fi Indicator / Color / Status		
Wi-Fi Indicator	Slowly Flashes Blue	Ready to Connect
	Quickly Flashes Blue	Wi-Fi Connecting
	Solid Blue	Wi-Fi Connected
Button Indicator Status		
Button Indicator	Color	Status
Power Button Indicator	Solid White	Power On
	Dim	Power Off
	Solid Red	Water Shortage
	Flashes Red	Water Tank is not Positioned Correctly

## 3. Memory Function

The humidifier will remember its previous mist level, night light color/brightness, and Wi-Fi connection settings when powered off. These settings will become active again when the humidifier is turned back on.



# Getting Started

1. Remove all packaging and protective foams.
2. Place the humidifier on a hard, flat, water-resistant surface. The humidifier should be least 12 inches/30 cm away from any walls.

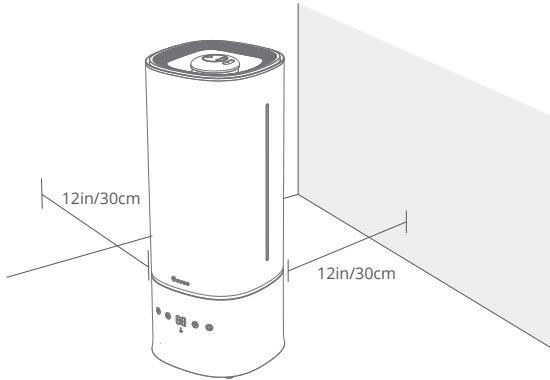

3. Mist should be directed away from walls, furniture, bedding, and appliances.

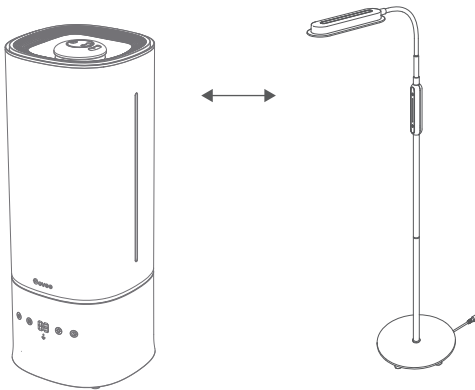

# Filling with Water

1. Remove the water tank cover using the small tab and add water directly into the tank. The tank can also be lifted off the based using the interior tank handle.

**Note:**

- Fill the tank with room-temperature water. Do not fill with hot water.
- It is recommended to fill the tank with purified or distilled water.
- Do not fill past the tank's max water line.

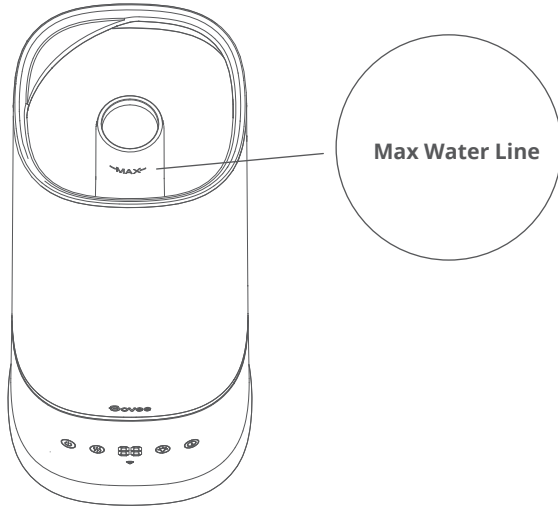

- Do not add water or essential oils directly into the base chamber.

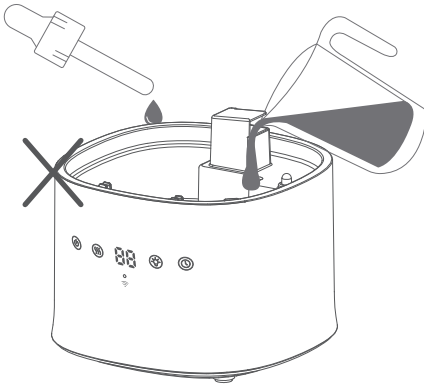

- Do not add water or essential oils into the mist tube.

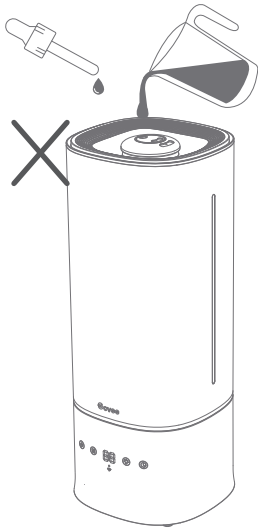

- Do not add essential oils directly into the humidifier. Only add essential oils to the aroma pad.

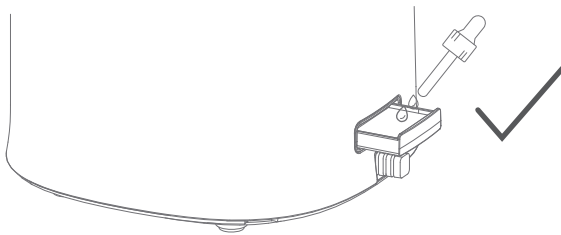

- Do not use water treatment liquids or third-party water filters with this humidifier.

2. Reattach the water tank cover and place the tank back on the base.

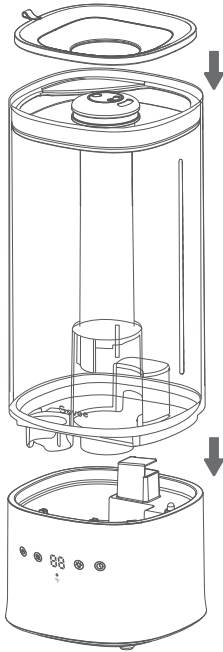

## Using Your Smart Humidifier

**Note:** Besides the on-device buttons, Govee Home App can also be used to control the below functions (as well as other app functions).

### Functions & Controls

Plug in your humidifier and press the Power Button to turn it on. Press the Mist Level Button repeatedly to cycle through Auto Mode and the three mist levels.

- **Auto Mode:** The humidifier will automatically adjust mist level according to the ambient humidity target set in-app, or 60% humidity when not connected to the app.
- **Custom Mode:** You can customize this setting (running time & mist level) via the app. You can create up to 3 custom presets in the app.
- **9 Levels of Mist Adjustment:** You can access up to 9 levels of mist via Govee Home App for even finer control of mist release.
- **UVC Light:** Turn on the interior UVC light via Govee Home App to kill most bacteria and mold in the base, making for cleaner mist.
- **Night Light:** Adjust the color and brightness of the integrated night light via the app.

- **360° Double Mist Nozzle:** Adjust the mist direction by rotating the two mist nozzles.

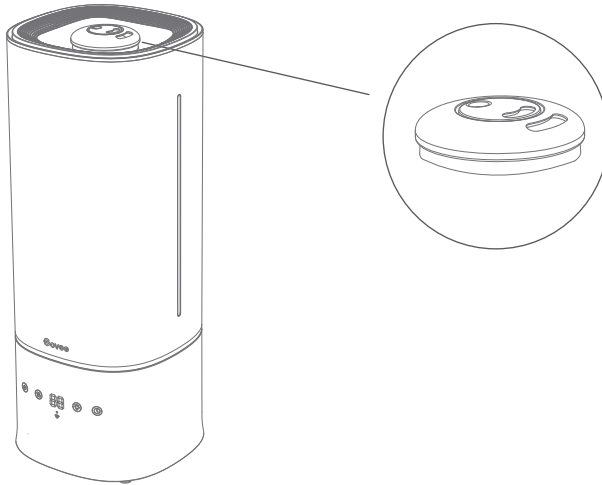

- **Humidity Monitor:** You can check the current environmental humidity via the on-device display or in Govee Home App.
- **Timers:** You can set a 1-to-24-hour timer via the Timer Button or Govee Home App.
- **Scheduling:** You can create up to 10 all-day schedules (power on/off & mist levels) via Govee Home App.
- **Third-party Voice Assistants:** You can control this humidifier via third-party voice control assistants such as Alexa and Google Assistant.

**Note:**

- **When the tank is detached from the base:** The humidifier's fan will stop within 5 seconds and mist will stop being produced. If the tank is properly placed back onto the base within 3 minutes, the humidifier will continue working; if not, the humidifier will automatically turn off.
- **No water left in the tank:** The humidifier will stop producing mist when there is not enough water in the tank. The indicator light will show solid red and the fan will stop working within 5 seconds. Once sufficient water is added back into the tank, the humidifier will restart after pressing the Power Button.

## Pairing Your Smart Humidifier with Govee Home App

Due to ongoing updates and improvements, Govee Home App's interface and features may be slightly different than those shown in the manual. In case of differences, follow the in-app instructions.

1. To download Govee Home App, scan the QR code or search for “GOVEE” in the Apple App Store (iOS) or Google Play Store (Android)



Govee Home App



**Note:** For Android users, choose to “Allow” permissions to use Govee Home App.

2. Turn on your smartphone’s Bluetooth.
3. Open Govee Home App, tap the “+” icon in the top right corner, and search for “H7142 .”
4. Tap the device icon and follow the on-screen instructions to complete pairing.

**Note:** You can use Govee Home App to connect your smart humidifier to Amazon Alexa or Google Assistant. Follow the in-app instructions to connect Govee Home App to each voice assistant.

## Using the Aroma Box

1. Press to pop out the aroma box from the back of the base.



2. Drip 8 to 10 drops of essential oil on the aroma pad.



3. Push the aroma box back into the humidifier.
4. Turn on the humidifier. The humidifier will automatically diffuse the aroma when used.

**Note:**

- Do not add essential oils, water treatment liquids, or third-party water filters directly into the water tank or base chamber. Only add essential oils to the aroma pad.
- The aroma pads can be cleaned and reused after diffusing essential oils.
- The aroma effect is intended to be light. This humidifier is not a dedicated aroma diffuser.

## Care & Maintenance

### Cleaning the Humidifier

The humidifier should be cleaned after being used for a week or before being stored.

#### Cleaning Steps

1. Unplug the humidifier.
2. Remove and rinse the water tank cover.

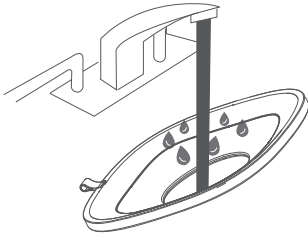

3. Remove the water tank from the base and pour out any water from the tank and base chamber.

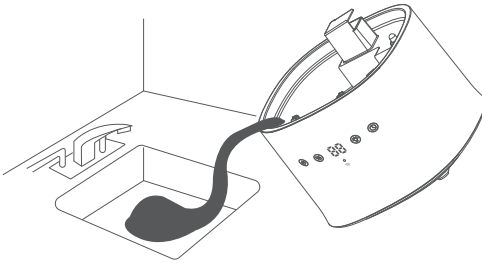

4. Rinse the tank and base chamber with room temperature water.

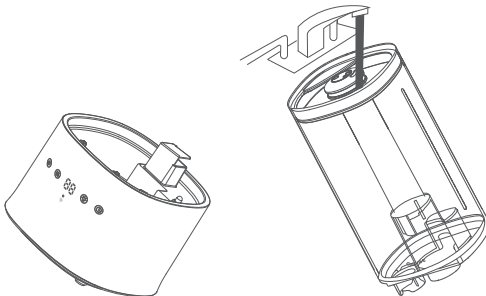

**Note:**

- Keep the air inlet and outlet dry when cleaning the base with running water. Internal components may be damaged if water enters the air inlet or outlet.
- If water does accidentally enter the base's inlet or outlet, place the humidifier base in a ventilated place to dry before using.

## Descaling the Humidifier

1. Fill the tank with 3 cups/710 mL of distilled white vinegar.

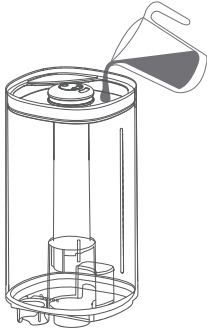

2. Put the tank cover on and swish the vinegar around the tank.

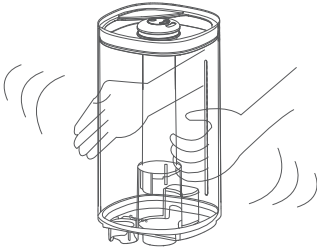

3. Place the tank on the base and soak for 15–20 minutes. Vinegar will drain into the base chamber and loosen scale (mineral buildup) in the tank and in the base chamber.

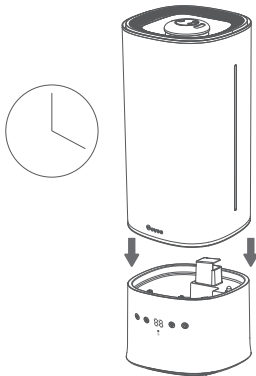



4. Remove the tank, remove the tank cover, and pour out all vinegar.

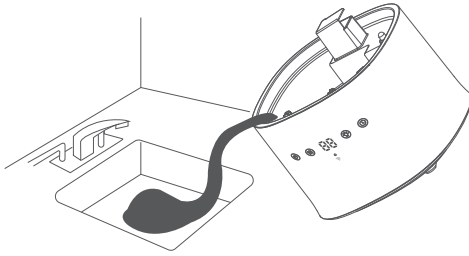

5. Remove the baffle and lift up the float. Use the cleaning brush to clean.

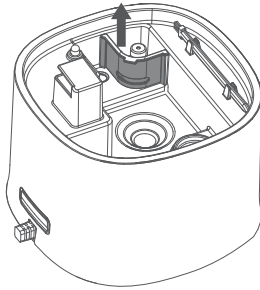

**Note:**

- Put the floating baffle back in place after removing it.

6. Use a soft cloth and the included cleaning brush to remove limescale from all parts.

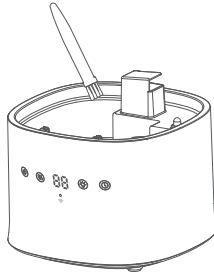

7. Rinse all parts until the vinegar smell is completely gone.

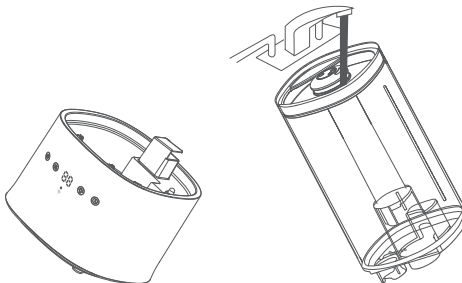

8. Dry all parts with a cloth. Make sure all parts are completely dry before reassembling or storing the humidifier.

## Cleaning the Aroma Pad

1. Press and pop out the aroma box from the back of the base.

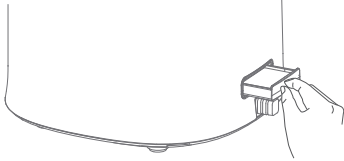

2. Remove the pad and rinse it under warm running water.

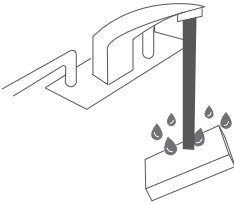

3. Dry the pad with a clean cloth and place it back into the aroma box.

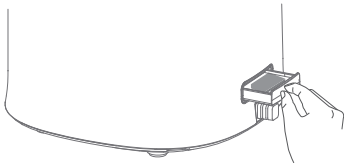

**Note:** Do not pour liquid cleaners or detergents into the aroma pad or box.

## Storing

Follow the cleaning instructions and allow all parts to dry completely before storing the humidifier in a cool, dry place.

# Troubleshooting

Problem	Possible Solution
Humidifier doesn't turn on or it powers off frequently.	Make sure the power cable is securely connected and press Power Button again.
	Check to see if the humidifier is in Auto Mode. If so, the humidifier may automatically turn off when the humidity level is above the target level.
Little or no mist comes out.	Add at least 1L purified or distilled water to the water tank.
	Turn the mist level to a higher setting.
	There may be too much water in the base chamber. Empty the base chamber and refill the water tank (not the base chamber) and place the water tank properly onto the base.
	Make sure the air inlet on the bottom of the base is not blocked. The humidifier should not be set on carpet or other surfaces that may block the air inlet.
	Make sure the nozzle is not blocked or clogged.
	Make sure the humidifier is on a level surface.
	Water temperature may be too low. Turn the mist level to the highest setting and let the humidifier run for a while, then adjust to the desired setting.
	The water temperature may be too low. Use room temperature water.
	If the water tank or base was washed with detergent, it should be rinsed thoroughly with clean water to remove residual detergent.
Humidifier uses water too fast.	The humidifier uses up water based on the environmental temperature and humidity. If the environment is cold and/or dry, the humidifier will run out of water faster.
Humidifier produces an unusual smell.	If the humidifier is new, unplug and rinse all parts, then place it in a cool and dry place for 12 hours.
	If essential oils were placed on the aroma pad, the pad should be rinsed with clean water and left to dry.
	Clean the water tank and base chamber.
Humidifier makes a loud or unusual noise.	Set the mist level to a lower setting.
	The humidifier may be malfunctioning. Stop using it and contact Govee Customer Support.
White dust appears around the humidifier.	We recommend using purified or distilled water to fill the humidifier. Avoid using water with high mineral content.
	Clean the water tank and base chamber.
	Make sure the silicone sealing ring around the water outlet valve is secure.

Water leaks from the humidifier.	Avoid running the humidifier in a room with over 60% relative humidity.
	Do not shake the humidifier.
	Make sure to place the humidifier on a flat, level surface.
	Check the water tank for leaks. If there are leaks, contact Govee Customer Support.
Condensation forms around humidifier or windows.	Humidity may be too high. Turn down the mist level, turn off the humidifier, or open a door or window to the room.
Mold grows inside the humidifier.	Clean the water tank and base chamber regularly.
Essential oil has little or no smell.	Add more essential oil. For best results, use pure essential oil.
Power indicator light shows solid red.	The tank is short of water. Please refill the tank.
Power indicator flashes red.	The water tank is not properly positioned. Please place the water tank correctly on the base.
The humidity shown on the display or in the app is not accurate.	The space the humidifier is being used in may be larger than that intended for this product. Please use the humidifier in a space less than 602ft <sup>2</sup> /56 m <sup>2</sup> .
	The humidity sensor at the bottom of the humidifier may be damp. Please turn off the humidifier and dry the base.
The night light cannot be turned on or adjusted via the app.	Check whether the app is connected to the humidifier.
	If the night light still cannot be operated when the app and the humidifier are connected, please contact Govee Customer Support.

# For App & Connectivity

## 1. Cannot connect to Govee Home App.

- Make sure the Bluetooth of your smartphone is enabled and your smartphone is not connected with other Bluetooth Humidifiers.
- Enable the smartphone's Location Services.
- Try connecting with another smartphone.
- Make sure your app is updated to the latest version.
- Make sure you have connected to the 2.4GHz network, and confirm the network is working correctly.
- Make sure the Wi-Fi password you entered is correct.
- Shorten the distance between the humidifier, Wi-Fi router, and the smartphone.
- Make sure your humidifier and the Wi-Fi router are not placed near appliances that produce electromagnetic radiation (e.g. microwave ovens, refrigerators, etc.).
- If you are using a VPN, try turning it off and then connecting the humidifier. Disable portal authentication for your Wi-Fi network. If portal authentication is enabled, this humidifier will not be able to access your Wi-Fi network, and setup will fail. Portal authentication means that you need to sign in to your Wi-Fi network through a web page before you can use the Internet.

## 2. Cannot find the humidifier within in nearby Bluetooth humidifiers list.

- The humidifier may be connected with another smartphone. Disconnect it from the other smartphone first.

## 3. The humidifier is offline.

- Make sure the humidifier is plugged in and powered on, then refresh "My Humidifiers" in Govee Home App by swiping down on the screen.
- Make sure your router is connected to the internet, and your phone's network connection is working.
- If the Wi-Fi password has changed, the humidifier will automatically go offline. Try connecting it to the network again.
- Delete the offline humidifier from Govee Home App, then add and reconfigure the humidifier again in the app.

# FCC Statement

This device complies with Parts 15 & 18 of the FCC Rules. Operation is subject to the following two conditions:

- (1) This device may not cause harmful interference, and
- (2) This device must accept any interference received, including interference that may cause undesired operation.

**Warning:** Changes or modifications not expressly approved by the party responsible for compliance could void the user's authority to operate the equipment.

**Note:** This equipment has been tested and found to comply with the limits for a Class B digital device, pursuant to Parts 15 & 18 of the FCC Rules. These limits are designed to provide reasonable protection against harmful interference in a residential installation.

This equipment generates uses and can radiate radio frequency energy and, if not installed and used in accordance with the instructions, may cause harmful interference to radio communications. However, there is no guarantee that interference will not occur in a particular installation. If this equipment does cause harmful interference to radio or television reception, which can be determined by turning the equipment off and on, the user is encouraged to try to correct the interference by one or more of the following measures:

- (1) Reorient or relocate the receiving antenna.
- (2) Increase the separation between the equipment and receiver.
- (3) Connect the equipment into an outlet on a circuit different from that to which the receiver is connected.
- (4) Consult the dealer or an experienced radio/TV technician for help.

# FCC Radio Frequency Exposure Statement

The device has been evaluated to meet general RF exposure requirements. The device can be used in fixed/mobile exposure condition. The min separation distance is 20cm.

FCC ID:2AQA6-H7142

The following importer is the responsible party

Responsible party :

Name: GOVEE MOMENTS(US) TRADING LIMITED

Address: 13013 WESTERN AVE STE 5 BLUE ISLAND IL 60406-2448

Email: support@govee.com

Contact information: <https://www.govee.com/support>

# IC Statment

This device complies with Industry Canada licence-exempt RSS standard(s). Operation is subject to the following two conditions:

- (1) This device may not cause interference, and
- (2) This device must accept any interference, including interference that may cause undesired operation of the device."

Le présent appareil est conforme aux CNR d'Industrie Canada applicables aux appareils radio exempts de licence. L'exploitation est autorisée aux deux conditions suivantes:

- (1) l'appareil nedoit pas produire de brouillage, et
- (2) l'utilisateur de l'appareil doit accepter tout brouillage radioélectrique subi, même si le brouillage est susceptible d'en compromettre le fonctionnement.

This Class B digital apparatus complies with Canadian ICES-001.

Cet appareil numérique de la classe B est conforme à la norme NMB-001 du Canada.

IC RF Statement:

When using the product, maintain a distance of 20cm from the body to ensure compliance with RF exposure requirements.

Lors de l'utilisation du produit, maintenez une distance de 20 cm du corps afin de vous conformer aux exigences en matière d'exposition RF.

The Bluetooth® word mark and logos are registered trademarks owned by Bluetooth SIG, Inc. and any use of such marks by Shenzhen Intellirocks Tech. Co., Ltd. is under license.

# Customer Service



 Warranty: 12-Month Limited Warranty

 Support: Lifetime Technical Support

 Email: support@govee.com

 Official Website: [www.govee.com](http://www.govee.com)

 @Govee  @goveeofficial  @govee.official

 @GoveeOfficial  @GoveeOfficial



Govee Home App

For FAQs and more information,  
please visit: [www.govee.com](http://www.govee.com)