

**Govee**

**Model:** H7123

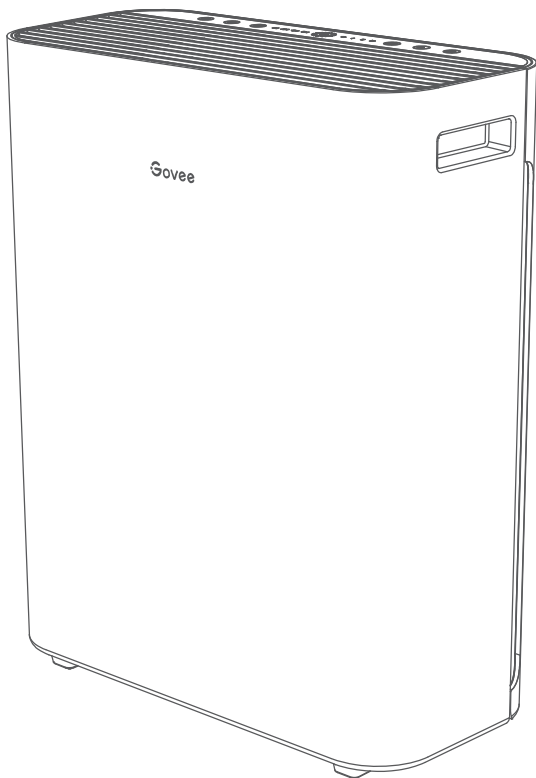

# **User Manual**

Govee Smart Pet Air Purifier



# Contents

**Safety Instructions** 01

**Included in the Box** 03

**Introduction** 04

**Getting Started** 08

**Govee Home App** 10

**Using the Filters** 11

**Care & Maintenance** 12

**Storing** 15

**Troubleshooting** 15

**Appendix** 19

# Govee Smart Pet Air Purifier User Manual

## READ AND SAVE THESE INSTRUCTIONS

### Safety Instructions

#### General Safety

- Only use the air purifier as described in this manual.
- Do not use the air purifier without removing the plastic wrap from the filter. If not removed, the air purifier will not filter air, and may overheat, causing a fire hazard.
- Do not use the air purifier outdoors.
- Keep the air purifier away from water or wet, damp areas. Never submerge it in water or liquid.
- Do not use the air purifier in excessively humid areas.
- Keep the air purifier away from heat sources such as stovetops, ovens, or radiators.
- Do not use the air purifier in places where combustible gases, vapors, metallic dust, aerosol (spray) products, or fumes from industrial oil are present.
- Keep the air purifier 5ft (1.5m) away from where oxygen is being administered.
- Supervise children when they are near the air purifier.
- Do not place anything into the openings of the air purifier.
- Do not place heavy objects on the air purifier.
- Keep the inside of the air purifier dry. To prevent moisture build up, avoid placing it in rooms with major temperature changes or underneath air conditioners.
- Always unplug the air purifier before servicing (such as changing the filter).
- Do not use the air purifier if it is damaged or not functioning well, or if the power cord or plug is damaged. Do not risk repairing the air purifier by yourself. Contact customer support for assistance.
- Not for commercial use. Household use only.

**WARNING:** To reduce the risk of fire or electric shock, do not use this air purifier in combination with any third party controls (such as a dimmer switch).

## Power Cord & Plug

- Place the air purifier near the electrical outlet it is plugged into.
- Never place the power cord near any heat sources.
- Do not cover the power cord with a rug, carpet, or other covering. Do not place the cord under furniture or appliances.
- Keep the power cord out of areas where people frequently move around. Place the cord in places where it will not be tripped over.
- The air purifier has a polarized plug (one prong is wider than the other), which fits into a polarized outlet in only one orientation. This is a safety feature to reduce the risk of electric shock. If the plug does not fit, reverse the plug to the correct orientation. If it still does not fit, do not bypass this safety feature and do not try forcing the plug into the outlet. Instead, do not use it with the outlet.
- This air purifier uses standard US 120V, 60Hz outlets. If using it outside the US, check the compatibility.

## LIRE ET CONSERVER CES INSTRUCTIONS

### La consignes de sécurité

- Utilisez le purificateur d'air intelligent seulement comme décrit dans ce manuel.
- Ne pas utiliser sans retirer le film plastique du filtre. S'il n'est pas retiré, le purificateur d'air ne filtrera pas l'air et peut surchauffer, provoquant un risque d'incendie.
- N'utilisez pas le purificateur d'air à l'extérieur.
- Gardez le purificateur d'air loin de l'eau ou des zones humides. Ne jamais placer dans l'eau ou dans un liquide.
- Ne pas utiliser dans des zones excessivement humides.
- Gardez le purificateur d'air éloigné des sources de chaleur telles que les fourneaux de cuisine, les fours ou les radiateurs.
- Ne pas utiliser là où des gaz combustibles, des vapeurs, des poussières métalliques, des produits en aérosol (la pulvérisation) ou des fumées d'huile industrielle sont présents.
- Gardez 5 pieds / 1,5 mètres de l'endroit où l'oxygène est administré.
- Surveillez les enfants lorsqu'ils sont à proximité du purificateur d'air.
- Ne placez rien dans les ouvertures du purificateur d'air.
- Ne placez pas d'objets lourds sur le purificateur d'air.
- Gardez l'intérieur du purificateur d'air sec. Pour éviter l'accumulation d'humidité, évitez de placer dans des pièces avec des changements de température importants ou sous des climatiseurs.

- Débranchez toujours le purificateur d'air avant l'entretien (comme lors du changement de filtre).
- N'utilisez pas le purificateur d'air s'il est endommagé ou ne fonctionne pas correctement, ou si le cordon d'alimentation ou la fiche est endommagé. Ne vous réparez pas vous-même. Contactez immédiatement le service client.
- Pas pour un usage commercial. Usage domestique uniquement.

**AVERTISSEMENT:** Pour réduire le risque d'incendie ou de choc électrique, n'utilisez pas ce purificateur d'air en combinaison avec des commandes tierces (telles qu'un gradateur).

## Le cordon d'alimentation & la fiche

- Placez le purificateur d'air près de la prise électrique dans laquelle il est branché.
- Ne placez jamais le cordon d'alimentation à proximité de sources de chaleur.
- Ne couvrez pas le cordon d'alimentation avec un tapis, une moquette ou un autre revêtement. Ne placez pas le cordon sous des meubles ou des appareils électroménagers.
- Gardez le cordon d'alimentation hors des zones où les gens marchent fréquemment. Placez le cordon là où il ne risque pas de trébucher.
- Ce purificateur d'air a une fiche polarisée (une broche est plus large que l'autre), qui s'insère dans une prise polarisée dans une seule orientation. Il s'agit d'une fonction de sécurité pour réduire le risque de choc électrique. Si la fiche ne rentre pas, inversez la fiche dans le bon sens. S'il ne rentre toujours pas, ne contournez pas cette fonction de sécurité et ne forcez pas la fiche dans la prise. Au lieu de cela, ne l'utilisez pas avec la prise.
- Ce purificateur d'air utilise des prises standard US 120V, 60Hz. Si vous utilisez en dehors des États-Unis, vérifiez la compatibilité.

## Included in the Box

Item	Quantity
Smart Pet Air Purifier	1
True HEPA Filter (Pre-Installed)	1
Quick Start Guide	1
User Manual	1

# Introduction

## Part Names

- A. Touch Control Panel
- B. Air Outlet
- C. Built-in Handle (Both sides)
- D. Housing
- E. Filter Cover
- F. Open Slot (Both sides)
- G. Air Inlet
- H. Power Cord
- I. Power Plug
- J. Filter Tab
- K. 4-Stage True HEPA Filter
- L. Particle Sensor

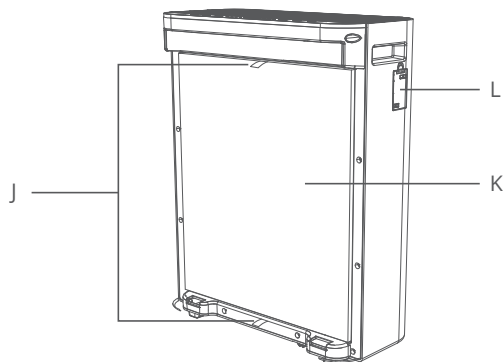
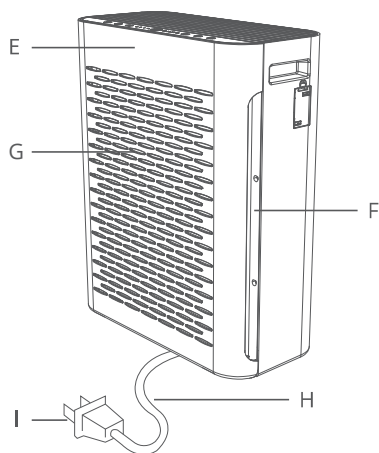
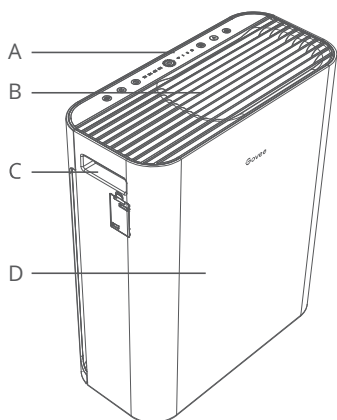

## Controls & Function

You can access additional features using Govee Home App.



### On/Off Button

Touch to turn on/off.

**Note:** When the device is turned on, its particle sensor needs 40s to preprocess and the air quality indicator is breathing white.



### Fan Speed Button

Touch to cycle through fan speeds: I (low), II (medium), and III (high).

**Note:** When the air purifier is in Auto Mode or Sleep Mode, touching the Fan Speed Button will exit those modes (if the screen display is on).



### Timer Button

Touch to cycle through the following timer options: 1H, 2H, 4H, and 8H. The purifier will turn off automatically when the set timer expires.



### Sleep Mode Button

Touch to turn Sleep Mode on or off. When Sleep Mode is on, the air purifier will work at its lowest noise setting and the panel will dim its brightness for more comfortable use at night.





### Auto Mode Button

Touch to turn Auto Mode on or off. When Auto Mode is on, the purifier will automatically adjust its fan speed based on the air quality.

**Note:** More settings can be accessed in the app.



### Pet Lock Button

Long press for 3s to lock/unlock the panel buttons. When locked, the buttons do not respond to any touch, preventing children or pets from accidentally changing any settings.

**Note:** The Lock Mode Indicator will flash 3 times to indicate it is still enabled when any other button is touched.



### Filter Change Indicator Button

Long press for 3s to reset the filter after replacing the old filter with a new one. If the change indicator flashes 3 times, the reset is completed. When the filter expires, the change indicator will light red.

**Note:**

- After the filter is reset, its usage time will be recalculated.
- The change indicator can also be reset by pressing the button for 3s even if it does not light up.
- For the best performance, use Govee filters that are adaptable to H7123 air purifiers.

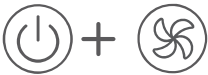

### Recovery Button

Long press for 10s until all indicators flash once to restore the air purifier to factory settings if it cannot function well. The air purifier will disconnect from Wi-Fi and Bluetooth and automatically reboot.

**Note:** After restoring the air purifier to factory settings, go to “My Devices” page on the app to delete this air purifier first. Otherwise, it cannot be added to the app again.

### Memory Function

The air purifier will save its previous settings when powered off (such as speed, mode, and Wi-Fi connection). When it is powered back on, the settings will resume.

## Indicator Status

Indicator	Working Status	Light Status
I	Low Speed	Solid White
II	Medium Speed	Solid White
III	High Speed	Solid White
1H	Auto-Off in 1 Hour	Solid White
2H	Auto-Off in 2 Hours	Solid White
4H	Auto-Off in 4 Hours	Solid White
8H	Auto-Off in 8 Hours	Solid White
	Fan Speed Mode is On	Solid White
	Sleep Mode is On	Dim
	Auto Mode is On	Solid White
	Locked	Solid White
	Unlocked	Off
	Locking Reminder	Triple Flashes
	Filter is Expired	Solid Red
	Filter Reset Successfully	Triple Flashes
	Ready for Wi-Fi Connection	Slowly Flashes White
	Wi-Fi is Connecting	Quickly Flashes White
	Wi-Fi is Connected	Solid White
	Particle Sensor Preprocessing	Breathing White
	Air Quality is Excellent	Green
	Air Quality is Good	Blue
	Air Quality is Moderate	Yellow
	Air Quality is Poor	Red

## Getting Started

1. Use the open slot on both sides to remove the purifier's filter cover and take the True HEPA filter out of the plastic packaging.

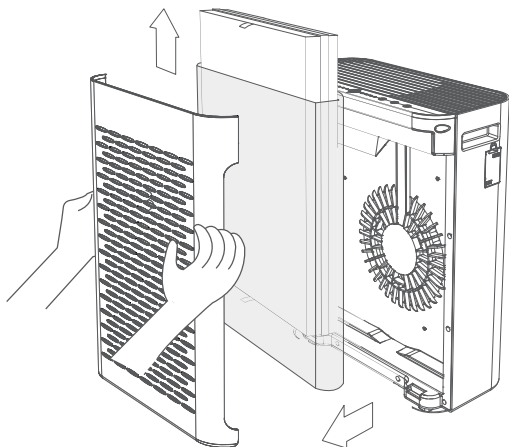

2. Place the filter back into the purifier with the filter tabs facing out.

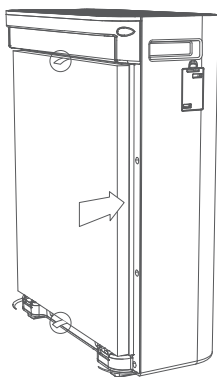

3. Replace the back cover by lining up the cover's feet with matching slots on the housing and push the cover closed.

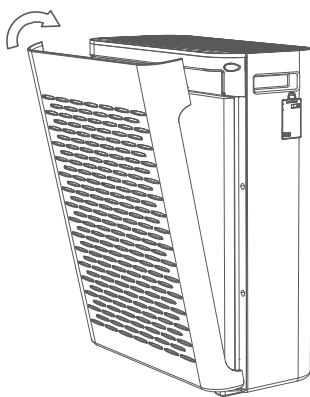

4. Place the purifier on a hard, flat surface. Leave 15 inches/38 cm of clearance to allow air to pass through the air inlets.

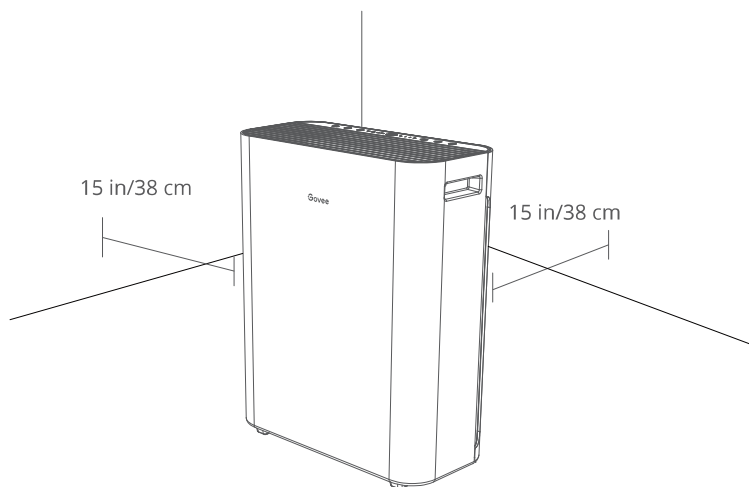

# Govee Home App

You can access more features using Govee Home App.

## Downloading Govee Home App

To download Govee Home App, scan the QR code or search for “Govee” in the Apple App Store® (iOS) or Google Play Store (Android).



Govee Home App



### Note:

- Choose “Allow” to the permissions requested when opening Govee Home App for the first time. These permissions allow the app’s features to function normally and are not used to record personal, private information.
- Due to ongoing updates, Govee Home App may be slightly different than shown in this manual. In case of any differences, always follow the in-app instructions.

## Pairing with Govee Home App

1. Turn on your smartphone’s Bluetooth.
2. Open Govee Home App, tap the “+” icon in the top right corner and search for “H7123”.
3. Tap the device icon and follow the in-app instructions to press the Power Button to complete the Bluetooth connection with your phone and connect your device with Govee Home App.

### Note:

- Method to turn off Bluetooth and Wi-Fi connection: Press and hold the Power Button and Fan Speed Button for 10s to restore the device to factory settings, then go to “My Devices” page on the app to delete this air purifier first. Otherwise, it cannot be added to the app again.
- You can use Govee Home App to connect your air purifier to Amazon Alexa or Google Assistant. Follow the in-app instructions to connect to each voice assistant.
- Govee Home App is being continually updated and its features do expand.

# Using the Filters

## 4-Stage Filtration System

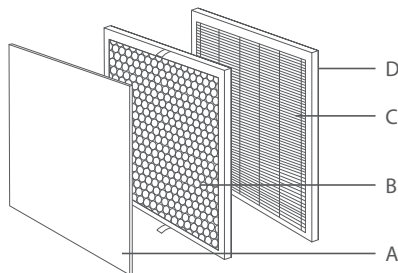

### A. Washable Pre-Filter

- Captures large particles such as dust, lint, fibers, hair, and pet fur.
- Maximizes the filter's life by protecting it from large debris.

### B. Modified High-Efficiency Activated Carbon Filter

- Physically absorbs smoke, odors, and fumes.
- Decomposes pet odors through chemical reaction.
- Filters compounds such as formaldehyde, benzene, ammonia, hydrogen sulfide, and volatile organic compounds (VOCs).

### C. H13 True HEPA Filter

- Captures at least 99.97% of airborne particles 0.3 microns ( $\mu\text{m}$ ) in size.
- Filters small particles such as fine dust, smoke particles, pollen, and pet dander.

### D. Low Resistance Nonwoven Fabrics

- Further blocks large particles, improves the effect of primary filtration, protects HEPA filter, and increases filter life.

## Clean Air Delivery Rate

- Clean Air Delivery Rate (CADR) measures the efficiency of an air purifier by indicating the volume of clean air that it produces per minute, which is based on the removal of three most common indoor air pollutants including dust, pollen, and smoke. The higher the CADR, the more particles the air purifier will remove and the larger the area it can clean.

**Note:**

- This air purifier has a Clean Air Delivery Rate of 135 cubic feet per minute (CFM), or 230 m<sup>3</sup>/h. The rating is measured at the air purifier's highest speed.
- The higher the CADR, the more particles the air purifier will remove and the larger the area it can clean.
- To effectively clean the air, keep windows and doors closed when the air purifier is on.

## Standard Environment Precautions

### Humidity

- Moisture may damage the filters. This air purifier should be used in an area with a humidity level below 85% RH. If you use the air purifier in excessively humid areas, the surface of the filter will become moldy.

### Essential Oils

- Do not add essential oils into the air purifier or filter. The filter will become damaged by the oil and will eventually release an unpleasant smell.
- Do not use diffusers near the air purifier.

## Care & Maintenance

**Caution:** Do not clean with abrasive chemicals or flammable cleaning agents.

## Cleaning the Smart Pet Air Purifier

1. Unplug the purifier from power before cleaning.
2. Wipe the outside of the air purifier with a soft, dry cloth. If necessary, wipe the housing with a damp cloth and leave it to dry.
3. Vacuum the inside of the air purifier.

## Cleaning the Particle Sensor Lens

1. Unplug the purifier from power.
2. Open the particle sensor cover.
3. Use a cotton swab dipped in water to clean the particle sensor lens.

4. Wipe the lens dry with a dry cotton swab.

**Note:** Do not remove the foam piece attached to the particle sensor cover unless instructed by customer support.

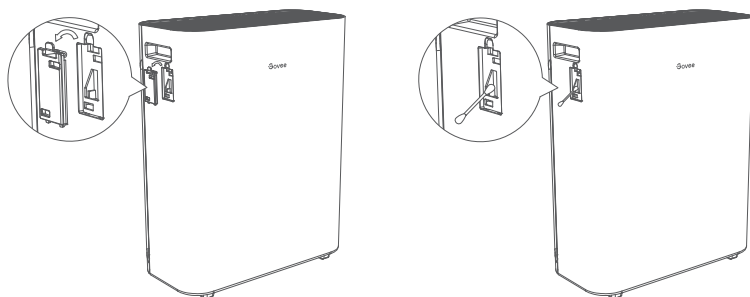

## Cleaning the Pre-Filter

The outer pre-filter should be cleaned to increase its efficiency and service life.

1. Carefully peel the pre-filter away from the True HEPA and Modified Activated Carbon Filters.
2. Clean the pre-filter with a soft brush or vacuum hose to remove hair, dust, and large particles.
3. Gently rinse the pre-filter with water and dry it completely before putting it back in place.
4. Replace the filter in housing.

**Note:** Do not clean the True HEPA and Activated Carbon Filters.

Filter	When to Clean	When to Replace
Washable Pre-Filter	Vacuum Every 2-4 weeks	6-8 months
	Wash Every 1-2 months	
True HEPA & High-Efficiency Activated Carbon Filter	Do Not Clean	

## Replacing The Filter

1. Unplug the air purifier.
2. Remove the old filter.



3. Clean out any remaining dust or hair inside the air purifier using a vacuum hose.  
Do not use water or liquids to clean the air purifier.
4. Unwrap the new filter and place it into the housing.
5. Reattach the cover. Plug in the air purifier.
6. Reset the Filter Change Indicator.

**Note:**

- To ensure the performance of your air purifier, only use official Govee filters. To buy replacement filters, visit Govee's online store.
- Remember to reset the Filter Change Indicator after changing the filter.

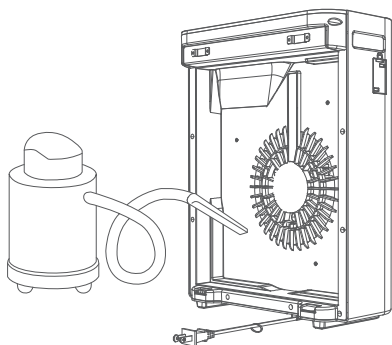





## Filter Change Time Period

The filter should be replaced every 6–8 months, depending on how often you use it. If you always use your purifier in a relatively high pollution environment, you may need to change the filter more frequently, even if the change indicator does not light up. Any of the following situations may indicate that you need to change your filter:

- Increased noise
- Decreased airflow
- Unusual odors
- A visibly clogged filter

## Resetting the Filter Change Indicator

When the Filter Change Indicator lights red, it indicates that the filter life needs to be reset.

- Long press  for 3s.  will flash 3 times and then die out once the filter life is successfully reset.
-  will light up as a reminder to replace the filter. The indicator will light up when you use the purifier for 6 to 8 months. When  turns on, you may not need to replace your filter immediately, but you should check the filter and plan to replace it soon.
- After you replace the filter, remember to reset the Filter Change Indicator.

## Storing

If not using the air purifier for an extended period of time, wrap both the air purifier and the filter in plastic packaging and store in a dry place to avoid moisture damage.







## Troubleshooting

The troubleshooting section below is for solving frequently asked questions for the purifier unit. If your problem persists, please contact customer support.

### For Smart Pet Air Purifier

Problem	Possible Solution
Air purifier cannot turn on or respond to button controls.	Plug the air purifier into power.
	Check if the power cord is damaged. If so, stop using the air purifier and contact Customer Support.
	Plug the air purifier into a different outlet.
	The air purifier may be malfunctioning. Contact Customer Support.
Airflow is significantly reduced.	Make sure the filter is removed from its packaging and properly in place.
	Tap  to increase the fan speed.

Problem	Possible Solution
Airflow is significantly reduced.	Ensure there are at least 15 inches / 38 cm of clearance on <b>all</b> sides of the air purifier.
	The pre-filter may be clogged by large particles such as hair or lint, blocking the air flow. Clean the pre-filter.
	Replace with a new filter.
Air purifier makes an unusual noise while the fan is on.	Make sure the filter is properly in place with plastic packaging removed.
	Make sure the air purifier is operating on a hard, flat, level surface.
	Replace the filter.
	The air purifier may be damaged, or a foreign object may be inside. Stop using the air purifier and contact Customer Support. Do not try to repair the air purifier.
Air quality indicator always stays red.	Clean the particle sensor lens.
	If you're using an ultrasonic humidifier near the air purifier, the mist may affect the accuracy of the particle sensor. The sensor will detect the large mist particles, and the air quality indicator may turn red. Avoid using an ultrasonic humidifier near the air purifier or avoid using Auto Mode.
Strange smell is coming from the air purifier or it has poor odor removal ability.	Clean the filter or replace if necessary.
	Make sure not to use your air purifier in an area with high humidity or while diffusing essential oils.
	Remove the filter and expose it to the sun, until the smell can be reduced from the activated carbon filter.

Problem	Possible Solution
Pet odor still exists after using the air purifier for a while.	Check if there is solid odor source and clean it. The purifier can only purify the air.
	The filter may be expired. Please change the filter.
	The room area might be too large. Use the filter within the effective range (312 ft <sup>2</sup> / 29 m <sup>2</sup> ).
Poor air purification quality.	Tap  to increase the fan speed.
	Make sure no objects are blocking the sides or the top of the air purifier (the inlet or outlet).
	Make sure the filter is fully removed from its packaging and is properly secured in place.
	Close doors and windows while using the air purifier.
	If the room is larger than 312 ft <sup>2</sup> / 29 m <sup>2</sup> , air purification will take longer. The air purifier may not be as effective in significantly larger rooms.
	Replace the filter.
Filter Change Indicator is still on after replacing the filter.	Press and hold  for 3s.  will flash 3 times and turn off once successfully reset.
Filter Change Indicator does not light up within 8 months.	 is a reminder for you to check the filter and will light up based on how frequently the air purifier has been used. If you don't use your air purifier often,  will take longer to turn on.
Filter Change Indicator lights up before 6 months.	 is a reminder for you to check the filter and will light up based on how long the air purifier has been used. If you run your air purifier frequently,  will turn on sooner.

## For App & Connectivity

1. Cannot connect to Govee Home App.
  - Make sure your smartphone is powered on and is not connected with other Bluetooth devices.
  - Enable the smartphone's Location Services.
  - Try connecting with another smartphone.
  - Make sure your app is updated to the latest version.
  - Make sure you connect to your Wi-Fi router's 2.4GHz network and that the network is working correctly.
  - Make sure the Wi-Fi password you entered is correct.
  - Shorten the distance between the air purifier, Wi-Fi router, and the smartphone.
  - Make sure your air purifier and the Wi-Fi router are located away from appliances that produce electromagnetic radiation (e.g. microwave ovens, refrigerators, etc).
  - If you are using a VPN, try turning it off and then connecting the air purifier.
  - Disable portal authentication for your Wi-Fi network. If portal authentication is enabled, this air purifier will not be able to access your Wi-Fi network and setup will fail. Portal authentication means that you need to sign in to your Wi-Fi network through a web page before you can use the Internet.
2. Cannot find the device on Bluetooth Device Nearby page of the app.
  - The air purifier may be connected with another smartphone. Disconnect it from the other smartphone first.
3. The air purifier is offline.
  - Make sure the air purifier is plugged in and powered on, then refresh "My Devices" in Govee Home App by swiping down on the screen.
  - Make sure your router is connected to the internet and your phone's network connection is working.
  - If the Wi-Fi password has been changed, the air purifier will automatically go offline. Try connecting it to the network again.
  - Delete the offline air purifier from Govee Home App, then add and reconfigure the air purifier again in the app.

# Appendix

## After-Sales Service

**Warranty:** 12-Month Limited Warranty

**Support:** Lifetime Technical Support

**Email:** support@govee.com

**Official Website:** www.govee.com

## Specifications

Adapter Input	120V~ 60Hz
Purifier Rated Power	31W
Effective Range	312 ft <sup>2</sup> / 29 m <sup>2</sup> <b>Note:</b> Effective for larger rooms, but purification will take longer.
CADR	135 cfm / 230 m <sup>3</sup> /h
Noise Level	24~52 dB
Air Purifier Dimensions	16 x 12.8 x 5.9 in / 40.6 x 32.5 x 15 cm
Air Purifier Weight	7.47lb / 3.39kg
Operating Conditions	Temperature: 14° to 104°F / -10° to 40°C
	Humidity: < 85% RH

## Compliance Information

### FCC Statement

This device complies with Part 15 of the FCC Rules. Operation is subject to the following two conditions: (1) this device may not cause harmful interference, and (2) this device must accept any interference received, including interference that may cause undesired operation.

**Warning:** Any Changes or modifications not expressly approved by the party responsible for compliance could void the user's authority to operate the equipment.

**Note:** This equipment has been tested and found to comply with the limits for a Class B digital device, pursuant to Part 15 of the FCC Rules. These limits are designed to provide reasonable protection against harmful interference in a residential installation.

This equipment generates uses and can radiate radio frequency energy and, if not installed and used in accordance with the instructions, may cause harmful interference to radio communications. However, there is no guarantee that interference will not occur in a particular installation. If this equipment does cause harmful interference to radio or television reception, which can be determined by turning the equipment off and on, the user is encouraged to try to correct the interference by one or more of the following measures:

- (1) Reorient or relocate the receiving antenna.
- (2) Increase the separation between the equipment and receiver.
- (3) Connect the equipment into an outlet on a circuit different from that to which the receiver is connected.
- (4) Consult the dealer or an experienced radio/TV technician for help.

## **FCC Radio Frequency Exposure Statement**

This equipment complies with FCC radiation exposure limits set forth for an uncontrolled environment. This equipment should be installed and operated with minimum distance 20cm between the radiator & your body.

The following importer is the responsible party

Name: GOVEE MOMENTS(US) TRADING LIMITED

Address: 13013 WESTERN AVE STE 5 BLUE ISLAND IL 60406-2448

Email: support@govee.com

Contact information: <https://www.govee.com/support>

## **Energy Star**

The energy efficiency of this ENERGY STAR certified model is measured based on a ratio between the model's CADR for Smoke and the electrical energy it consumes, or CADR/Watt.

The Bluetooth® word mark and logos are registered trademarks owned by Bluetooth SIG, Inc. and any use of such marks by Shenzhen Intellirocks Tech. Co., Ltd. is under license.



Govee Home App

For FAQs and more information,  
please visit: [www.govee.com](http://www.govee.com)