

Govee

Model: H7120

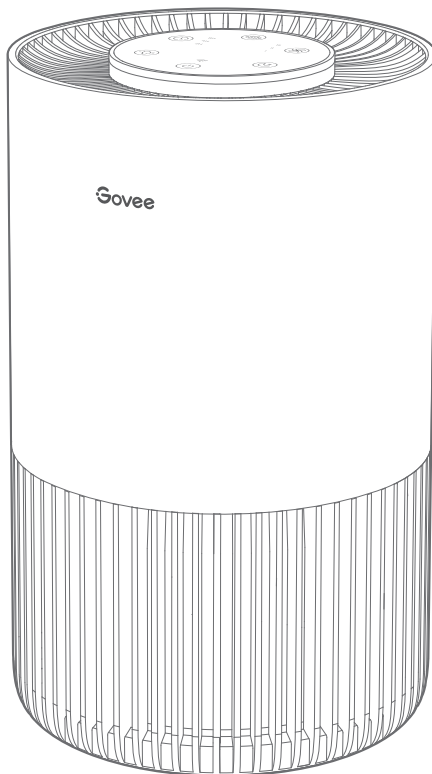

User Manual

Govee Air Purifier

Contents

Safety Instructions	01
Included in the Box	02
Introduction	03
Getting Started	06
Govee Home App	07
Using the Filters	08
Care & Maintenance	10
Storing	12
Troubleshooting	12
Appendix	14

READ AND SAVE THESE INSTRUCTIONS

Safety Instructions

General Safety

- Only use the air purifier as described in this manual.
- Do not use the air purifier without removing the plastic wrap from the filter. If not removed, the air purifier will not filter air, and may overheat, causing a fire hazard.
- Do not use the air purifier outdoors.
- Keep the air purifier away from water or wet, damp areas. Never submerge it in water or liquid.
- Do not use the air purifier in excessively humid areas.
- Keep the air purifier away from heat sources such as stovetops, ovens, or radiators.
- Do not use the air purifier in places where combustible gases, vapors, metallic dust, aerosol (spray) products, or fumes from industrial oil are present.
- Keep the air purifier 5ft (1.5m) away from where oxygen is being administered.
- Supervise children when they are near the air purifier.
- Do not place anything into the openings of the air purifier.
- Do not place heavy objects on the air purifier.
- Keep the inside of the air purifier dry. To prevent moisture build up, avoid placing it in rooms with major temperature changes or underneath air conditioners.
- Always unplug the air purifier before servicing (such as changing the filter).
- Do not use the air purifier if it is damaged or not functioning well, or if the cord or adapter is damaged. Do not risk repairing the air purifier by yourself. Contact customer support for assistance.
- Not for commercial use. Household use only.

WARNING: To Reduce The Risk Of Fire Or Electric Shock, Do Not Use This Air Purifier With Any Solid-State Speed Control Device.

Power Adapter & Cord

- Place the air purifier near the electrical outlet it is plugged into.
- Never place the cord near any heat sources.
- Do not cover the cord with a rug, carpet, or other covering. Do not place the cord under furniture or appliances.
- Keep the cord out of areas where people frequently move around. Place the cord in places where it will not be tripped over.

If the power adapter cord is damaged, it must be replaced by qualified persons in order to avoid an electric or fire hazard.

Included in the Box

Item	Quantity
Air Purifier	1
HEPA Filter (Pre-Installed)	1
Aroma Pad	1 (In the Aroma Box) 2 (External)
Quick Start Guide	1
User Manual	1

Note: Essential oils are not included.

Introduction

Part Names

- a. Air Outlet
- b. Touch Control Panel
- c. Aroma Pad
- d. Aroma Box
- e. Housing
- f. DC Input Port
- g. Air Inlet
- h. Filter Cover Handle
- i. Non-Slip Pads
- j. 3-in-1 HEPA Filter
- k. Adapter Output Cable
- l. Power Adapter

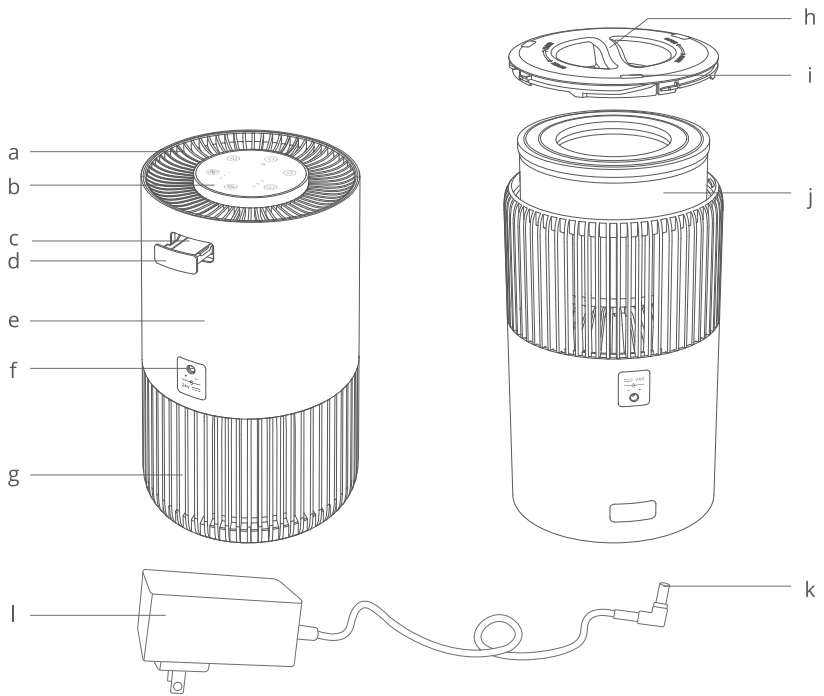

Control

You can access additional features using Govee Home App.

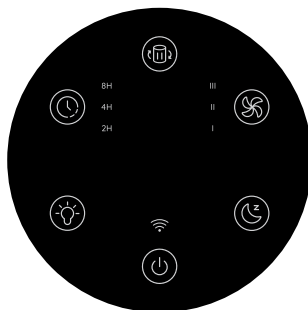

1.Controls & Functions



On/Off Button

Touch to turn on/off.



Fan Speed Button

Touch to cycle through fan speeds: I (low), II (medium), and III (high).

Note: When the air purifier is in Sleep Mode, touching the Fan Speed Button will exit those modes (if the screen display is on).



Timer Button

Touch to cycle through the following timer options: 2H, 4H, and 8H. The air purifier will turn off automatically when the set timer expires.



Sleep Mode Button

Touch to turn Sleep Mode on or off. When Sleep Mode is on, the air purifier will work at its lowest noise setting and the panel will dim its brightness for more comfortable use at night.



Night Light Button

Touch to turn the Night Light on or off

Note:

- Please open Govee Home App to access more settings of the night light about brightness, colors, lighting effects etc. The parameters will be saved and will restore automatically when the night light is turned on next time.
- The night light will turn off automatically when the air purifier is turned off.
- The night light can still be turned on when the air purifier is on the Off mode.



Filter Change Indicator Button

Long press for 3s to reset the filter after replacing the old filter with a new one. If the filter change indicator flashes 3 times, the reset is completed. When the filter expires, the change indicator will light red.

Note:

- After the filter is reset, its usage time will be recalculated.
- The filter change indicator can also be reset by pressing the button for 3s even if it does not light up.
- For the best performance, use Govee filters that are adaptable to H7120 air purifier.

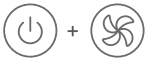

Recovery Button

Long press for 5s until all indicators flash once to restore the air purifier to factory settings if it cannot function well. The air purifier will disconnect from Wi-Fi and Bluetooth and automatically reboot.

Note: After restoring the air purifier to factory settings, go to “My Devices” page on the app to delete this air purifier first, otherwise, it cannot be added to the app again.

Memory Function

The air purifier will save its previous settings when powered off (such as speed, mode, and Wi-Fi connection). When it is powered back on, the settings will resume.

Indicator Status

Indicator	Working Status	Light Status
I	Low Speed	Solid White
II	Medium Speed	Solid White
III	High Speed	Solid White
2H	Auto-Off in 2 Hours	Solid White
4H	Auto-Off in 4 Hours	Solid White
8H	Auto-off in 8 Hours	Solid White
	Night Light is On	Solid White
	Sleep Mode is On	Dim
	Filter is Expired	Solid Red
	Filter Reset Successfully	Triple Flashes
	Ready for Wi-Fi Connection	Slowly Flashes White
	Wi-Fi is Connecting	Quickly Flashes White
	Wi-Fi is Connected	Solid White

Getting Started

Using the Air Purifier

1. Rotate the bottom filter cover counterclockwise and take it out

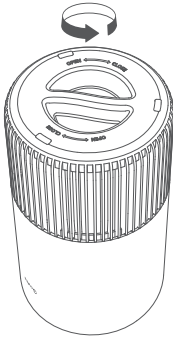

2. Remove the filter from its plastic packaging and place it back into the air purifier.

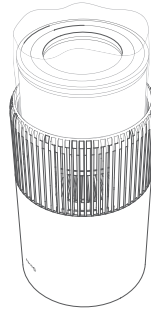

3. Reattach the filter cover and rotate clockwise to lock. The sound of "dah" indicates the filter cover is tightened up.

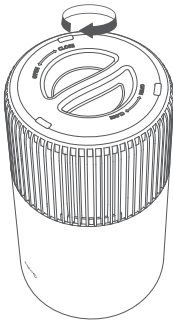

4. Place the air purifier on a flat, stable surface with the panel facing up. Allow at least 8in/20cm of clearance on all sides of the air purifier. Keep away from anything that would block airflow, such as curtains and cabinets.

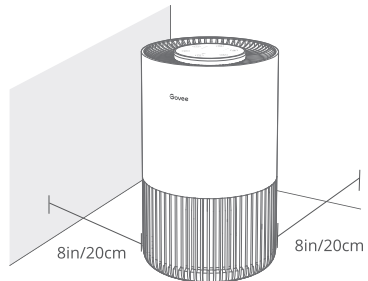

5. Insert the adapter output cable into the DC input port, then plug the power adapter into a 120V socket. Now your purifier is ready to use!

Using the Aroma Box

1. Press to pop out the aroma box from the back of the base.

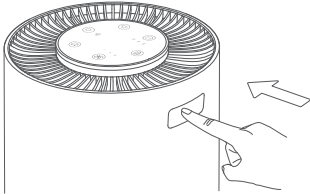

2. Add 8 to 10 drops of essential oil on the aroma pad. Be careful not to spill essential oil out of the aroma box to avoid contaminating the inside of the product.

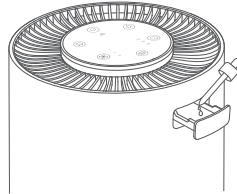

3. Push the aroma box back into the air purifier.

4. Turn on the air purifier. The air purifier will automatically diffuse the aroma when using.

Note: For better aromatherapy, always clean the aroma pad before adding new essential oils. Do not mix essential oils.

Govee Home App

You can access more features using Govee Home App.

Downloading Govee Home App

To download Govee Home App, scan the QR code or search for “Govee” in the Apple App Store® (iOS) or Google Play Store (Android).



Govee Home App



Note:

- Choose “Allow” to the permissions requested when opening Govee Home App for the first time. These permissions allow the app’s features to function normally and are not used to record personal, private information.
- Due to ongoing updates, Govee Home App may be slightly different than shown in this manual. In case of any differences, always follow the in-app instructions.

Pairing with Govee Home App

1. Turn on your smartphone's Bluetooth.
2. Open Govee Home App, tap the "+" icon in the top right corner and search for "H7120".
3. Tap the device icon and follow the in-app instructions to complete the Bluetooth and Wi-Fi connection.

Note:

- Method to turn off Bluetooth and Wi-Fi connection: Press and hold the Power Button and Fan Speed Button for 5s to restore the device to factory settings, then go to "My Devices" page on the app to delete this air purifier first, otherwise it cannot be added to the app again.
- You can use Govee Home App to connect your air purifier to Amazon Alexa or Google Assistant. Click the icon on right upper corner of the details page of the device to follow the in-app instructions to connect to each voice assistant.
- Govee Home App is being continually updated and its features do expand.

Using the Filters

3-Stage Filtration System

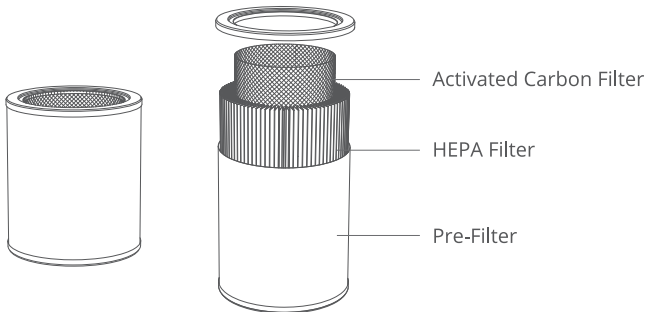

A. Pre-Filter

- Captures large particles such as dust, lint, fibers, hair, and pet fur.
- Maximizes the filter's life by protecting it from large debris.

B. HEPA Filter

- Captures 0.3 microns (μm) airborne particles.
- Filters small particles such as fine dust, smoke particles, pollen, and pet dander.

C. Activated Carbon Filter

- Physically adsorbs smoke, odors, and fumes.
- Filters compounds such as formaldehyde, benzene, ammonia, hydrogen sulfide, and volatile organic compounds (VOCs).

Essential Oils

- Only add essential oils to the aroma pad located in the aroma box near the top of the air purifier.
- Do not add essential oils to the air purifier or filter. The filter will become damaged by the oil and will eventually release an unpleasant smell.

Clean Air Delivery Rate

- Clean Air Delivery Rate (CADR) measures the efficiency of an air purifier by indicating the volume of clean air that it produces per minute, which is based on the removal of three most common indoor air pollutants including dust, pollen, and smoke. The higher the CADR, the more particles the air purifier will remove and the larger the area it can clean.
- This air purifier has a Clean Air Delivery Rate of 70 cubic feet per minute (CFM), or 119 m³/h, which is measured at the air purifier's highest speed.

Note:

- This air purifier has a Clean Air Delivery Rate of 70 cubic feet per minute (CFM), or 119 m³/h. The rating is measured at the air purifier's highest speed.
- The higher the CADR, the more particles the air purifier will remove and the larger the area it can clean.
- To effectively clean the air, keep windows and doors closed when the air purifier is on.

Standard Environment Precautions

Humidity

Moisture may damage the filters. This air purifier should be used in an area with a humidity level below 85% RH. If you use the air purifier in excessively humid areas, the surface of the filter will become moldy.

Care & Maintenance

Caution: Do not clean with abrasive chemicals or flammable cleaning agents.

Cleaning the Air Purifier

1. Unplug the purifier from power before cleaning.
2. Wipe the outside of the air purifier with a soft, dry cloth. If necessary, wipe the housing with a damp cloth and leave it to dry.
3. Vacuum the inside of the air purifier.

Cleaning the Pre-Filter

Do not clean the filter with water or other liquids. The outer pre-filter should be cleaned every 2-4 weeks to increase its efficiency and extend its lifespan. The pre-filter should be cleaned by a soft brush or vacuum hose to remove hair, dust, and large particles.

Filter	When to Clean	When to Replace
Pre-Filter	Vacuum Every 2-4 Weeks	6-8 Months
True HEPA & High-Efficiency Activated Carbon Filter	Do Not Clean	

Note: A 3-stage filter includes a Nylon Pre-Filter, HEPA Filter, and Carbon Filter. The three parts of the filter should be replaced as a single unit.

Replacing the Filter

1. Unplug the air purifier.
2. Remove the old filter.
3. Clean out any remaining dust or hair inside the air purifier using a vacuum hose. Do not use water or liquids to clean the air purifier.
4. Unwrap the new filter and place it into the housing.
5. Reattach the cover. Plug in the air purifier.
6. Reset the Filter Change Indicator.

Note:

- To ensure the best performance of your air purifier, only use official Govee filters. To buy replacement filters, visit Govee's online store.
- Remember to reset the Filter Change Indicator after changing the filter.

Filter Change Time Period





The filter should be replaced every 6–8 months, depending on how often you use it. If you always use your purifier in a relatively high pollution environment, you may need to change the filter more frequently, even if the change indicator does not light up.

Any of the following situations may indicate that you need to change your filter:

- Increased noise when the air purifier is on
- Decreased airflow
- Unusual odors
- A visibly clogged filter

Resetting the Filter Change Indicator

When the Filter Change Indicator lights red, it indicates that the filter life needs to be reset.

- Long press  for 3s.  will flash 3 times and then die out once the filter life is successfully reset.
-  will light up as a reminder to replace the filter. The indicator will light up when you use the purifier for 6 to 8 months. When  turns on, you may not need to replace your filter immediately, but you should check the filter and plan to replace it soon.
- After you replace the filter, remember to reset the Filter Change Indicator.

Cleaning the Aroma Pad

1. Press to pop out the aroma box and take it out.
2. Take the aroma pad and wash it with warm water.
3. Clean it with a clean cloth and put it back into the aroma box.
4. Push the aroma box back into the air purifier.

Note: Do not pour liquid cleaners or detergents onto the aroma pad or into the aroma box.

Replacing the Aroma Pad

- The aroma pad might need to be changed if it is deformed or damaged after repetitive washing.
- If you are refilling the same fragrance oil onto the pad then you probably will have to change pads during a 90–120 day period.
- To ensure better effects of the aromatherapy, only use official Govee aroma pads.

Storing







If not using the air purifier for an extended period of time, wrap both the air purifier and the filter in plastic packaging and store in a dry place to avoid moisture damage.

Troubleshooting

The troubleshooting section below is for solving frequently asked questions for the purifier unit. If your problem persists, please contact customer support.

For Air Purifier

Problem	Possible Solution
Air purifier cannot turn on or respond to button controls.	Plug in the air purifier.
	Check to see if the power cord is damaged. If so, stop using the air purifier and contact Customer Support.
	Plug the air purifier into a different outlet.
	The air purifier may be malfunctioning. Contact Customer Support.
Airflow is significantly reduced.	Make sure the filter is removed from its packaging and properly in place.
	Tap  to increase the fan speed.
	Make sure there are at least 8in/20cm of clearance on all sides of the air purifier.
	The pre-filter may be clogged by large particles such as hair or lint, blocking the air flow. Clean the pre-filter.
	Replace with a new filter.
Air purifier makes an unusual noise while the fan is on.	Make sure the filter is properly in place with plastic packaging removed.
	Make sure the air purifier is operating on a hard, flat, level surface. Replace the filter.
	The air purifier may be damaged, or a foreign object may be inside. Stop using the air purifier and contact Customer Support. Do not try to repair the air purifier.
Strange smell is coming from the air purifier or it has poor odor removal ability.	Clean the filter and aroma pad or replace if necessary.
	Make sure not to use your air purifier in an area with high humidity.
	Remove the filter and expose it to the sun, until the smell can be reduced from the activated carbon filter.

Poor air purification quality.	Tap  to increase the fan speed.
	Make sure no objects are blocking the sides or the top of the air purifier (the inlet or outlet).
	Make sure the filter is fully removed from its packaging and is properly secured in place.
	Close doors and windows while using the air purifier.
	If the room is larger than 150ft ² /14m ² , air purification will take longer. The air purifier may not be as effective in significantly larger rooms.
	Replace the filter.
Filter Change Indicator is still on after replacing the filter.	Press and hold  for 3s.  will flash 3 times and turn off once successfully reset.
Filter Change Indicator does not light up within 8 months.	 is a reminder for you to check the filter and will light up based on how frequently the air purifier has been used. If you don't use your air purifier often,  will take longer to turn on.
Filter Change Indicator lights up before 6 months.	 is a reminder for you to check the filter and will light up based on how long the air purifier has been used. If you run your air purifier frequently,  will turn on sooner.

For App & Connectivity

- Cannot connect to Govee Home App.
 - Make sure your smartphone is powered on and is not connected with other Bluetooth devices.
 - Enable the smartphone's Location Services.
 - Try connecting with another smartphone.
 - Make sure your app is updated to the latest version.
 - Make sure you connect to your Wi-Fi router's 2.4GHz network and that the network is working correctly.
 - Make sure the Wi-Fi password you entered is correct.
 - Shorten the distance between the air purifier, Wi-Fi router, and the smartphone. Make sure your air purifier and the Wi-Fi router are located away from appliances that produce electromagnetic radiation (e.g. microwave ovens, refrigerators, etc).

- If you are using a VPN, try turning it off and then connecting the air purifier.
 - Disable portal authentication for your Wi-Fi network. If portal authentication is enabled, this air purifier will not be able to access your Wi-Fi network and setup will fail. Portal authentication means that you need to sign in to your Wi-Fi network through a web page before you can use the Internet.
2. Cannot find the device on Bluetooth Device Nearby page of the app.
- The air purifier may be connected with another smartphone. Disconnect it from the other smartphone first.
3. The air purifier is offline.
- Make sure the air purifier is plugged in and powered on, then refresh “My Devices” in Govee Home App by swiping down on the screen.
 - Make sure your router is connected to the internet and your phone’s network connection is working.
 - If the Wi-Fi password has been changed, the air purifier will automatically go offline. Try connecting it to the network again.
 - Delete the offline air purifier from Govee Home App, then add and reconfigure the air purifier again in the app.

Appendix

After-Sales Service

 Warranty: 12-Month Limited Warranty

 Support: Lifetime Technical Support

 Email: support@govee.com

 Official Website: www.govee.com

 @Govee  @goveeofficial  @govee.official

 @GoveeOfficial  @GoveeOfficial

Specifications

Power Input(Adapter)	100-240V AC 50/60Hz
Power Input(Air Purifier)	24VDC
Rated Power	11.5W
Effective Range	150ft ² /14m ² Note: <ul style="list-style-type: none">● Effective for larger rooms, but purification will take longer.● Determined by CADR.
CADR	Smoke: 52.9cfm/90m ³ /h
	Dust: 72.9cfm/124m ³ /h
	Pollen: 82.2cfm/140m ³ /h
	PM2.5: 62.1cfm/106m ³ /h
Noise Level	24~46 dB
Air Purifier Dimensions	6.9*6.9*11in/17.5*17.5*28.1cm
Air Purifier Weight	3lb/1.4kg
Working Temperature	14° to 104°F/-10° to 40°C
Working Humidity	< 85% RH

Compliance Information

FCC Statement

This device complies with Part 15 of the FCC Rules. Operation is subject to the following two conditions:

- (1) This device may not cause harmful interference, and
- (2) This device must accept any interference received, including interference that may cause undesired operation.

Warning: Any Changes or modifications not expressly approved by the party responsible for compliance could void the user's authority to operate the equipment.

Note: This equipment has been tested and found to comply with the limits for a Class B digital device, pursuant to Part 15 of the FCC Rules. These limits are designed to provide reasonable protection against harmful interference in a residential installation.

This equipment generates uses and can radiate radio frequency energy and, if not installed and

used in accordance with the instructions, may cause harmful interference to radio communications. However, there is no guarantee that interference will not occur in a particular installation. If this equipment does cause harmful interference to radio or television reception, which can be determined by turning the equipment off and on, the user is encouraged to try to correct the interference by one or more of the following measures:

- (1) Reorient or relocate the receiving antenna.
- (2) Increase the separation between the equipment and receiver.
- (3) Connect the equipment into an outlet on a circuit different from that to which the receiver is connected.
- (4) Consult the dealer or an experienced radio/TV technician for help.

FCC Radio Frequency Exposure Statement

This equipment complies with FCC radiation exposure limits set forth for an uncontrolled environment. This equipment should be installed and operated with minimum distance 20cm between the radiator & your body.

The following importer is the responsible party

Name: GOVEE MOMENTS(US) TRADING LIMITED

Address: 13013 WESTERN AVE STE 5 BLUE ISLAND IL 60406-2448

Email: support@govee.com

Contact information: <https://www.govee.com/support>

Energy Star

The energy efficiency of this ENERGY STAR certified model is measured based on a ratio between the model's CADR for Smoke and the electrical energy it consumes, or CADR/Watt.

The Bluetooth® word mark and logos are registered trademarks owned by Bluetooth SIG, Inc. and any use of such marks by Shenzhen Intellirocks Tech. Co., Ltd. is under license.

Govee is a trademark of Shenzhen Intellirocks Tech. Co., Ltd.

Copyright ©2021 Shenzhen Intellirocks Tech. Co., Ltd. All Rights Reserved.



Govee Home App

For FAQs and more information,
please visit: www.govee.com