

H6054说明书

版本:1.0

料号:836-6054-23501

折叠尺寸:105×145 (mm)

展开尺寸:630×145 (mm)

材质:80G书页纸

工艺:四色印刷

折叠方式:风琴页

Safety Instructions

Read and follow the safety instructions below:

- The light bars are not waterproof. Avoid exposing them to splashes or drops of water.
- The working temperature should be between -10° to 45°C (14° to 113°F).
- The internal light source of the light bars cannot be replaced. If damaged, the light bars must be replaced.
- Do not let children install the light bars alone.
- Avoid installing the light bars near heat sources.
- External dimmers cannot be used with the light bars.
- Avoid installing the light bars near potentially dangerous sources (e.g., candles, liquid-filled objects).

Introduction

Thank you for choosing the Govee Flow Pro. The ColorSense camera technology can capture colors onscreen automatically, and then apply them to your light bars. This lighting effect syncs perfectly with your movies and gaming worlds, bringing you an immersive experience. The Flow Pro also supports voice control, allowing you to light up your life hands-free.

What You Get

| | |
|-------------------------|---|
| Light Bar | 2 |
| Control Box | 1 |
| Camera | 1 |
| Adapter | 1 |
| Table Mounting Bracket | 2 |
| Screen Mounting Bracket | 2 |
| Foam Sticker | 7 |
| User Manual | 1 |
| Service Card | 1 |

01

At a Glance

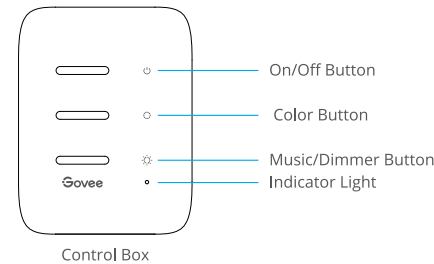

| | |
|----------------------------|---|
| On/Off Button | Press to turn On/Off. |
| Color Button | Press to adjust the color. |
| Music/Dimmer Button | Press to enter Music mode. |
| Button | Long press to adjust the brightness. |
| Indicator Light | a. A red light indicates the device is not connected to the network. |
| | b. A blue light indicates the device has successfully connected to the network. |
| | c. No light indicates the device is not powered on or might be broken. |

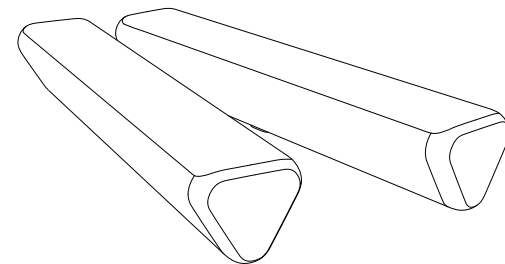

02

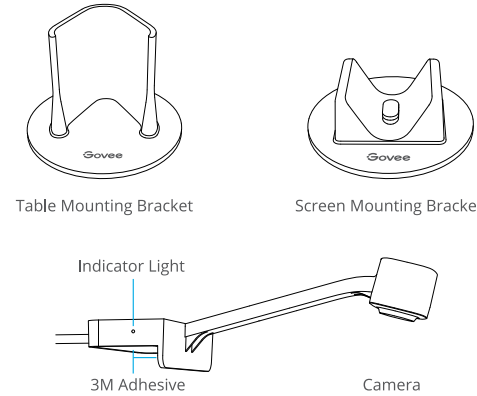

| | |
|------------------------|---|
| Indicator Light | a. A blue light indicates the camera is powered on. |
| | b. A dim light indicates the camera is not powered on or might be broken. |

Installing Your Device

- 1 Place the light bars on both sides of the table or mount them to the TV screen with the mounting bracket.

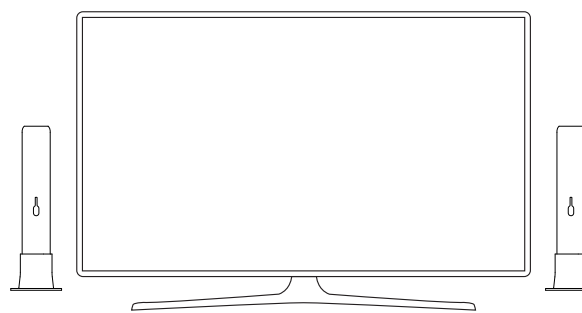

03

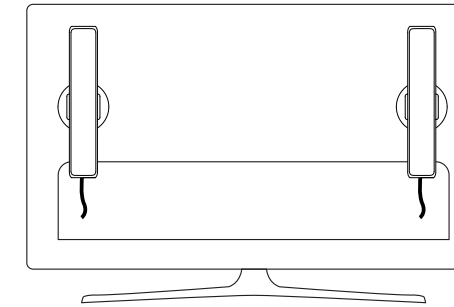

- 2 Position the camera in the center either above or below the screen.

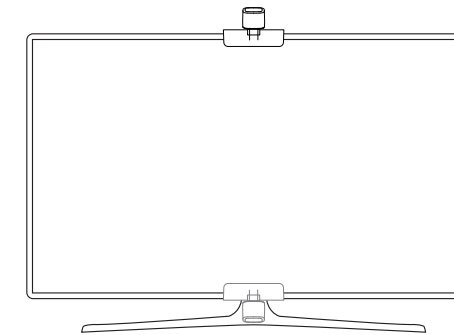

- 3 Insert the light bar and the camera cable into the corresponding control box sockets.
- 4 Power on the adapter, and then connect it to the control box.
- 5 Installation completed!

04

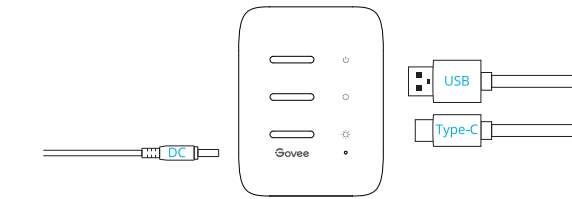

Pairing Your Device with the Govee Home App

What You Need:

- A Wi-Fi router supporting the 2.4GHz and 802.11 b/g/n bands. 5GHz is not supported.
 - A smartphone or tablet running iOS 8.0 (or above) or Android 4.3 (or above).
- 1 Download the Govee Home app from the App Store (iOS devices) or Google Play (Android devices).
 - 2 Open the app, tap the "+" icon in the top right corner and search for "H6054".
 - 3 Tap the device icon and follow the onscreen instructions to complete pairing.

Calibrating the Camera with the Govee Home App

- 1 Ensure the camera is positioned in the top-center or bottom-center of the screen.

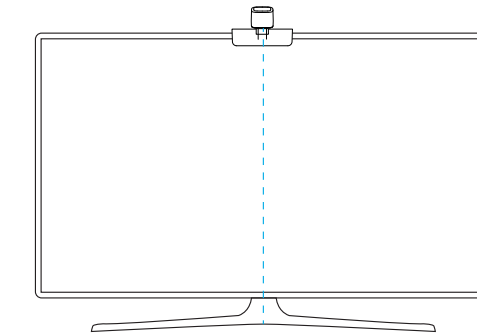

05

- 2 Stick the provided foam stickers to the 7 position points on the screen.

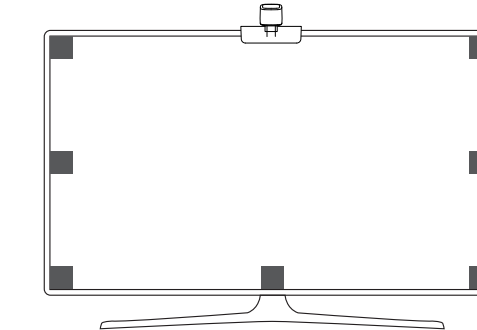

- 3 Open the Govee Home app, go to the Settings page, then tap "Calibration". Begin calibration by following the app instructions.

What You Need:

- a. Drag the calibration points to the position points.

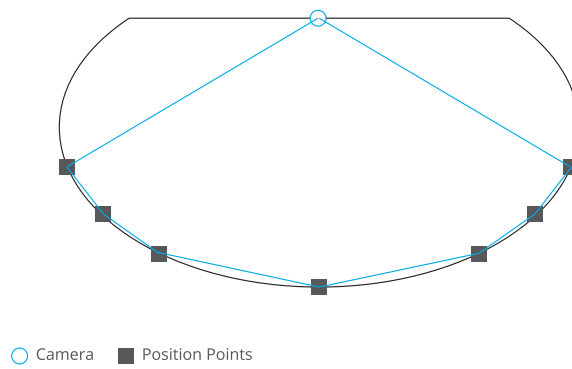

06

b. The picture may be distorted under the fish eye camera. Ensure the calibration point is chosen correctly, and the calibration lines do not overlap or cross each other.

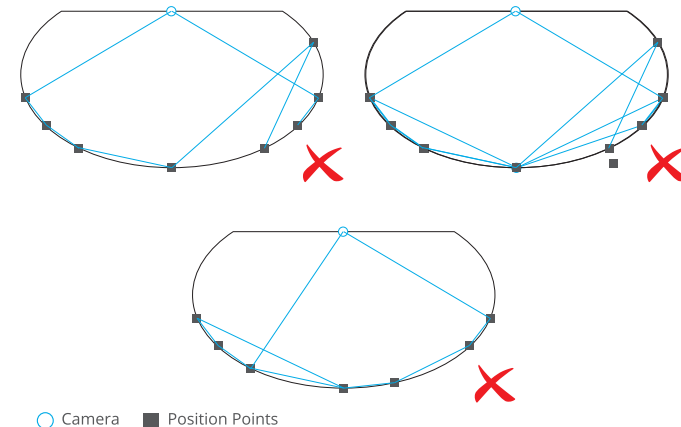

Specifications

| | |
|---------------------|-----------------------------|
| Working Voltage | AC 100-240V |
| Input | 12V/2A |
| Lumen | 400lm |
| Color | RGBWW |
| Color Temperature | 2200-6500K |
| Camera Pixel | 2M pixels |
| Working Temperature | -10° to 45°C (14° to 113°F) |



Govee Home App

For FAQs and more information, please visit: www.govee.com

Troubleshooting

- Cannot connect to Wi-Fi.
 - Check if the camera is powered on. A blue indicator light means it is powered on.
 - Do not skip the Wi-Fi connection steps during the device pairing process.
 - Ensure your Wi-Fi router is 2.4GHz (5GHz is not supported).
 - Ensure you entered the correct Wi-Fi password during the Wi-Fi set up process.
 - Use another smartphone to pair with the device to check if your network works.
 - Shorten the distance between the device and the Wi-Fi router to less than 50ft, then reconnect.
- Video mode, the light color is not consistent with the colors onscreen.
 - Ensure there are no strong, external lights affecting the camera.
 - Ensure the camera is installed at the top-center or bottom-center of the screen.
 - Calibrate the camera again by following the instructions provided previously.
- Calibration failed.
 - Check the stability of the Wi-Fi connection. A stable Wi-Fi connection is required for successful calibration.
 - Follow the app instructions to calibrate.
- Cannot pair or connect with Alexa or Google Assistant.
 - Ensure the Wi-Fi connection is stable and working properly.
 - Go to the app Settings page and follow the instructions under "User Guide" to pair the device again.
- The synchronization effect for Music mode does not work properly.
 - Ensure the control box is close to the music source, which will help the mic pick up sounds better.
- The 3M adhesive tape behind the camera or screen mounting bracket is not sticking.
 - Wipe the surface of the wall to ensure it is dry and clean.
 - After attaching the camera or mounting bracket, firmly press down several times to ensure it sticks completely.

- Can multiple users control one device?
 - Each device can only be controlled by one account.
 - If multiple users want to control the same device, ensure that they are all using the same account.

Customer Service

Warranty: 12-Month Limited Warranty

Support: Lifetime Technical Support

Email: support@govee.com

Official Website: www.govee.com

@Govee @govee_official @govee.official

@Goveeofficial @Govee.smarthome

FCC Statement

This device complies with Part 15 of the FCC Rules. Operation is subject to the following two conditions:
 (1) This device may not cause harmful interference, and (2) This device must accept any interference received, including interference that may cause undesired operation.
 Warning: Changes or modifications not expressly approved by the party responsible for compliance could void the user's authority to operate the equipment.

NOTE: This equipment has been tested and found to comply with the limits for a Class B digital device, pursuant to Part 15 of the FCC Rules.

These limits are designed to provide reasonable protection against harmful interference in a residential installation. This equipment generates uses and can radiate radio frequency energy and, if not installed and used in accordance with the instructions, may cause harmful interference to radio communications. However, there is no guarantee that interference will not occur in a particular installation. If this equipment does cause harmful interference to radio or television reception, which can be determined by turning the equipment off and on, the user is encouraged to try to correct the interference by one or more of the following measures:

1. Reorient or relocate the receiving antenna.
2. Increase the separation between the equipment and receiver.
3. Connect the equipment into an outlet on a circuit different from that to which the receiver is connected.
4. Consult the dealer or an experienced radio/TV technician for help.

FCC Radiation Exposure Statement

This equipment complies with FCC radiation exposure limits set forth for an uncontrolled environment. This equipment should be installed and operated with minimum distance 20cm between the radiator & your body.

Govee is a trademark of Shenzhen Intellirocks Tech Co.Ltd.
 Copyright ©2020 Shenzhen Intellirocks Tech Co.Ltd. All Rights Reserved.

User Manual



Model: H6054
 Flow Pro Light Bar