

3.2 x 1.6 x 0.5(mm) WiFi/Bluetooth Ceramic Chip Antenna (FH100G) Engineering Specification

1. Product Number

FH	3216	D1	R	2445	01
1	2	3	4	5	
1	2	3	4	5	



(1)Product Type	Chip Antenna
(2)Size Code	3.2x1.6mm
(3)Type Code	H5
(4)Packing	Paper Tape
(5)Frequency	2.45GHz



深圳福汇科技有限公司
Shenzhen Fuhui Technology Co. Ltd

Prepared by : **harry**

Designed by : **andy**

Checked by : **andy**

Approved by : **oliver**

TITLE : 3.2x1.6 x 0.5mm) WiFi/Bluetooth Ceramic Chip Antenna (YF400B) Engineering Specification

DOCUMENT NO.

FH3216D1R244501

REV.
A

2. Features

- *Stable and reliable in performances
- *Low temperature coefficient of frequency
- *Low profile, compact size
- *RoHS compliance
- *SMT processes compatible

3. Applications

- *Bluetooth earphone systems
- *Hand-held devices when WiFi /Bluetooth functions are needed, e.g., Smart phone.
- *IEEE802.11 b/g/n
- *ZigBee
- *Wireless PCMCIA cards or USB dongle

4. Description

Fu hui chip antenna series are specially designed for WiFi/Bluetooth applications. Based on yingfeng proprietary design and processes, this chip antenna has excellent stability and sensitivity to consistently provide high signal reception efficiency.

5. Electrical Specifications (40 x 40 mm² ground plane)

5-1. Electrical Table

Characteristics		Specifications	Unit
Outline Dimensions		3.2x1.6x0.5	mm
Working Frequency		2400~2500	MHz
VSWR		2 Max.	
Impedance		50	Ω
Polarization		Linear Polarization	
Gain	Peak	2 (typical)	dBi
	Efficiency	75 (typical)	%

5-2. Return Loss & VSWR



深圳福汇科技有限公司
Shenzhen Fuhui Technology Co.Ltc

Prepared by : **harry**

Designed by : **andy**

Checked by : **andy**

Approved by : **oliver**

TITLE : 3.2x1.6 x 0.5mm) WiFi/Bluetooth Ceramic Chip
Antenna (YF400B) Engineering Specification

**DOCUMENT
NO.**

FH3216D1R244501

REV.
A

Return Loss (S₁₁)

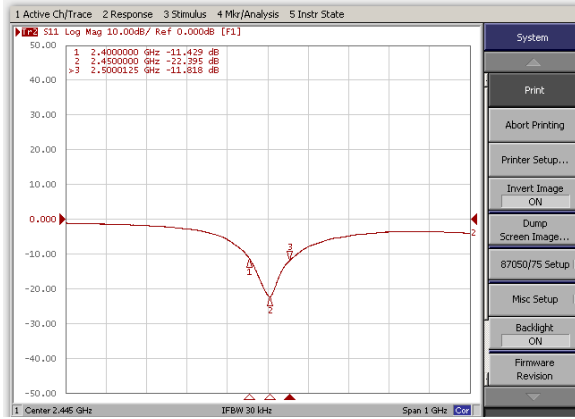

Smith Chart(S₁₁)

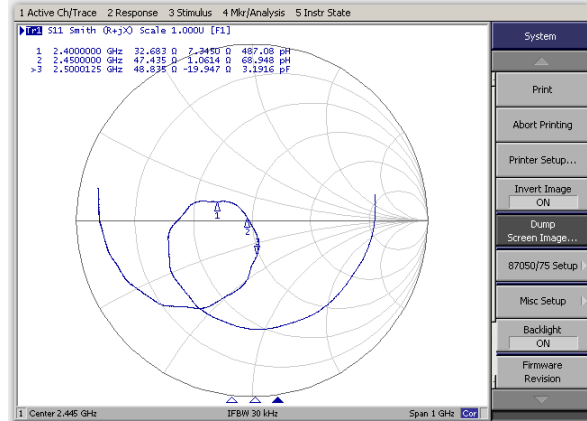

6 Outline Dimensions of Antenna & Evaluation Board (unit: mm)

6-1. Antenna Dimensions

Configuration and Dimensions:

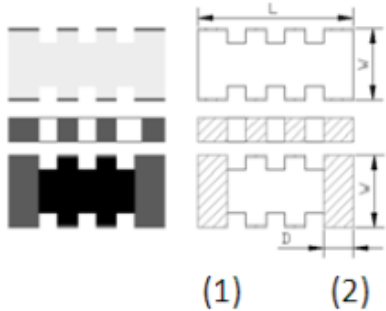

Dimension (mm)	
L	3.20±0.15
W	1.60±0.15
T	0.55±0.10
D	0.60±0.15

No.	Terminal Name
1	Feeding/Soldering
2	Soldering/Feeding

*P.S : Symmetrical,
No direction*



深圳福汇科技有限公司
Shenzhen Fuhui Technology Co.Ltc

Prepared by : **harry**

Designed by : **andy**

Checked by : **andy**

Approved by : **oliver**

**TITLE : 3.2x1.6 x 0.5mm) WiFi/Bluetooth Ceramic Chip
Antenna (YF400B) Engineering Specification**

**DOCUMENT
NO.**

FH3216D1R244501

**REV.
A**

6-2-2. Matching Circuit:

With the following recommended values of matching and tuning components, the center frequencies will be about 2450 MHz at our standard 40x40 mm² evaluation board. However, these are reference values, may need to be changed when the circuit boards or part vendors are different.

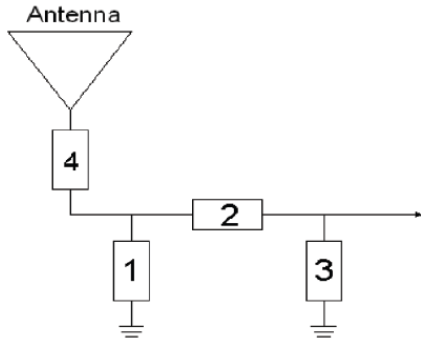

System Matching Circuit Component		
Location	Description	Vendor
1	N/A*	-
2	3.3nH, (0402)	DARFON
3	1.5pF, (0402)	MURATA
4	0Ω, (0402)	-

Evaluation Board Reference

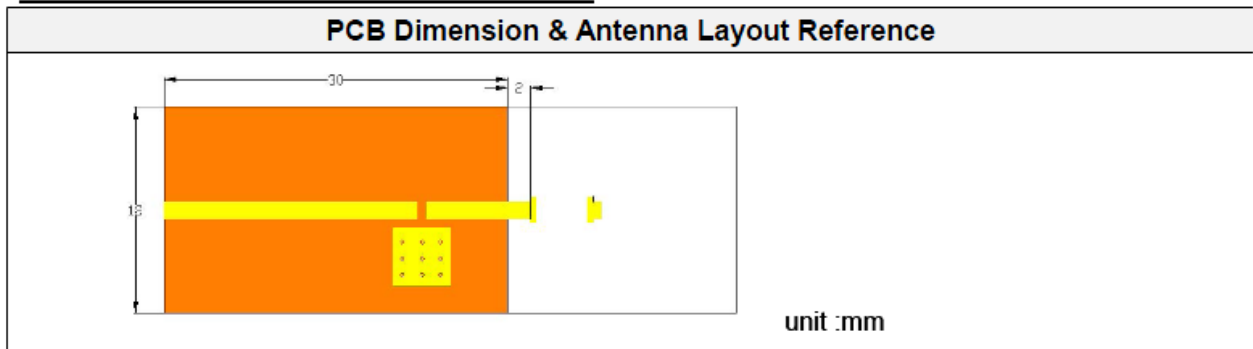

深圳福汇科技有限公司
Shenzhen Fuhui Technology Co.Ltc

Prepared by : **harry**

Designed by : **andy**

Checked by : **andy**

Approved by : **oliver**

TITLE : 3.2x1.6 x 0.5mm) WiFi/Bluetooth Ceramic Chip
Antenna (YF400B) Engineering Specification

DOCUMENT
NO.

FH3216D1R244501

REV.
A

7.Radiation Pattern (40x 40 mm² ground plane)

7-1. 3D Gain Pattern @ 2450 MHz

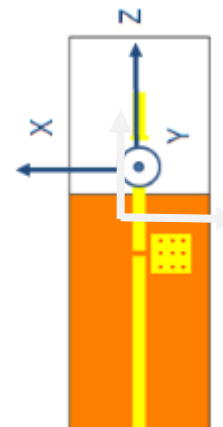
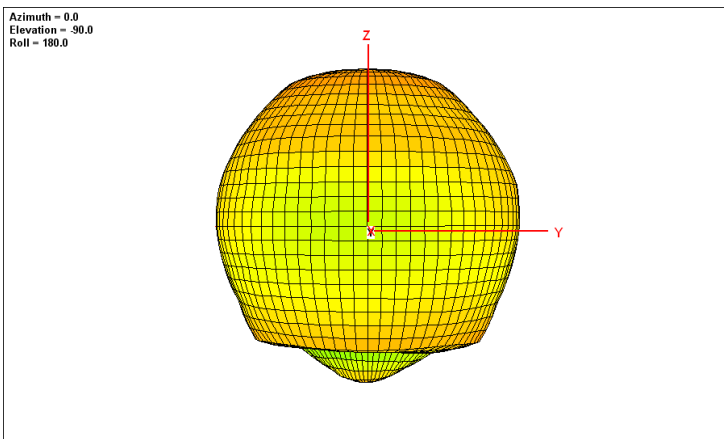
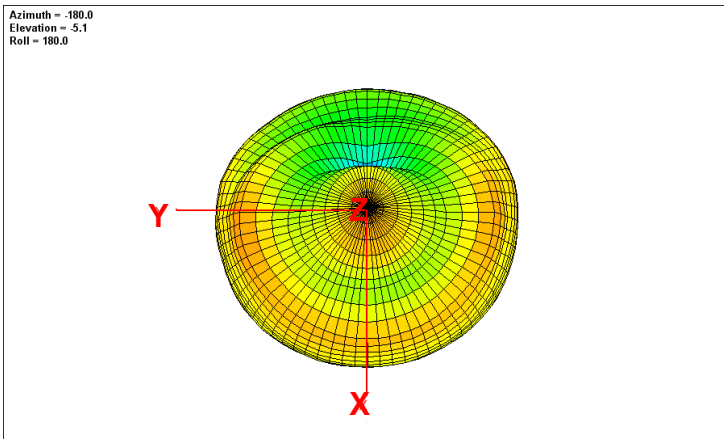
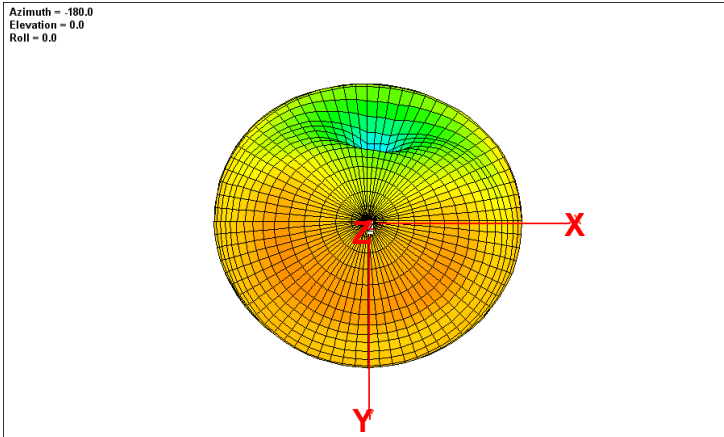

深圳福汇科技有限公司
Shenzhen Fuhui Technology Co.Ltc

Prepared by : **harry**

Designed by : **andy**

Checked by : **andy**

Approved by : **oliver**

TITLE : 3.2x1.6 x 0.5mm) WiFi/Bluetooth Ceramic Chip Antenna (YF400B) Engineering Specification

DOCUMENT NO.

FH3216D1R244501

REV.
A

Taping Specifications

Reel and Taping Specification

Reel Specification

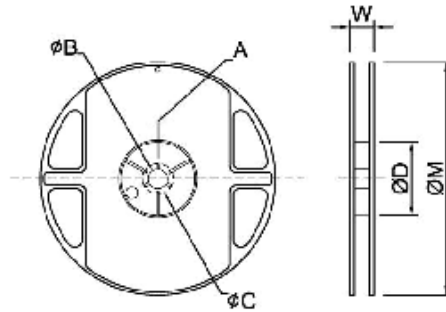

TYPE	SIZE	A	φB	φC	φD	W	φM
3216	7" 5K/Reel	2.0±0.5	13.5±1.0	21±1.0	60±1.0	11.5±2.0	178±2.0

Taping Specification

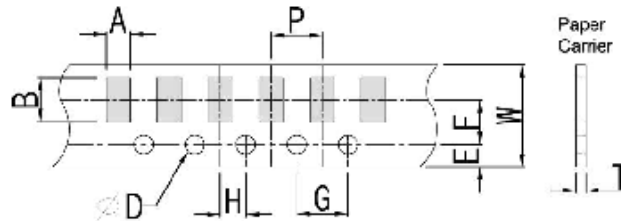

Packaging	Type	A	B	W	E	F	G	H	T	φD	P
Paper Type	3216	1.90±0.20	3.50±0.20	8.0±0.20	1.75±0.10	3.5±0.05	4.0±0.10	2.0±0.05	0.75±0.10	1.50 +0.10 -0	4.0±0.1

Reliability Table



深圳福汇科技有限公司
Shenzhen Fuhui Technology Co.Ltc

Prepared by : **harry**

Designed by : **andy**

Checked by : **andy**

Approved by : **oliver**

TITLE : 3.2x1.6 x 0.5mm) WiFi/Bluetooth Ceramic Chip
Antenna (YF400B) Engineering Specification

**DOCUMENT
NO.**

FH3216D1R244501

**REV.
A**

Reliability Table

Test Item	Procedure	Requirements Ceramic Type	Remark (Reference)
Electrical Characterization		Fulfill the electrical specification	User Spec.
Thermal Shock	<ol style="list-style-type: none"> 1. Preconditioning: $50 \pm 10^\circ\text{C}$ / 1 hr, then keep for 24 ± 1 hrs at room temp. 2. Initial measure: Spec: refer Initial spec. 3. Rapid change of temperature test: -30°C to $+85^\circ\text{C}$; 100 cycles; 15 minutes at Lower category temperature; 15 minutes at Upper category temperature. 	No Visible Damage. Fulfill the electrical specification.	MIL-STD-202 107
Temperature Cycling	<ol style="list-style-type: none"> 1. Initial measure: Spec: refer Initial spec. 2. 100 Cycles (-30°C to $+85^\circ\text{C}$), Soak Mode=1 (2 Cycle/hours). 3. Measurement at 24 ± 2 Hours after test condition. 	No Visible Damage. Fulfill the electrical specification.	JESD22 JA104
High Temperature Exposure	<ol style="list-style-type: none"> 1. Initial measure: Spec: refer Initial spec. 2. Unpowered; 500hours @ $T=+85^\circ\text{C}$. 3. Measurement at 24 ± 2 hours after test. 	No Visible Damage. Fulfill the electrical specification.	MIL-STD-202 108
Low Temperature Storage	<ol style="list-style-type: none"> 1. Initial measure: Spec: refer Initial spec. 2. Unpowered: 500hours @ $T= -30^\circ\text{C}$. 3. Measurement at 24 ± 2 hours after test. 	No Visible Damage. Fulfill the electrical specification.	MIL-STD-202 108
Solderability (SMD Bottom Side)	Dipping method: <ol style="list-style-type: none"> a. Temperature: $235 \pm 5^\circ\text{C}$ b. Dipping time: $3 \pm 0.5\text{s}$ 	The solder should cover over 95% of the critical area of bottom side.	IEC 60384-21/22 4.10
Soldering Heat Resistance (RSH)	Preheating temperature: $150 \pm 10^\circ\text{C}$. Preheating time: 1~2 min. Solder temperature: $260 \pm 5^\circ\text{C}$. Dipping time: $5 \pm 0.5\text{s}$	No Visible Damage.	IEC 60384-21/22 4.10
Vibration	5g 's for 20 min., 12 cycles each of 3 orientations Note: Use 8×5 " PCB .031" thick 7 secure points on, one long side and 2 secure points at corners of opposite sides. Parts mounted within 2" from any secure point. Test from 10-2000 Hz	No Visible Damage.	MIL-STD-202 Method 204
Mechanical Shock	Three shocks in each direction shall be applied along the three mutually perpendicular axes of the test specimen (18 shocks) Peak value: 1,500g's Duration: 0.5ms Velocity change: 15.4 ft/s Waveform: Half-sine	No Visible Damage.	MIL-STD-202 Method 213
Humidity Bias	<ol style="list-style-type: none"> 1. Humidity: 85% R.H., Temperature: $85 \pm 2^\circ\text{C}$. 2. Time: 500 ± 24 hours. 3. Measurement at 24 ± 2 hrs after test condition. 	No Visible Damage. Fulfill the electrical specification.	MIL-STD-202 Method 106



深圳福汇科技有限公司
Shenzhen Fuhui Technology Co.Ltc

Prepared by : **harry**

Designed by : **andy**

Checked by : **andy**

Approved by : **oliver**

TITLE : 3.2x1.6 x 0.5mm) WiFi/Bluetooth Ceramic Chip Antenna (YF400B) Engineering Specification

DOCUMENT NO.

FH3216D1R244501

REV.

A

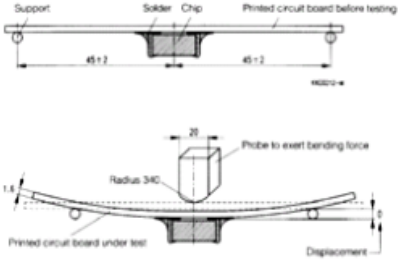
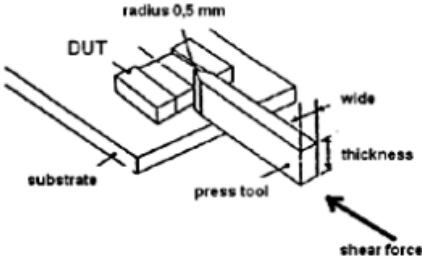
Board Flex (SMD)	<p>1. Mounting method: IR-Reflow. PCB Size (L:100 × W:40 × T:1.6mm)</p> <p>2. Apply the load in direction of the arrow until bending reaches 2 mm.</p> 	No Visible Damage.	AEC-Q200 005
Adhesion	<p>Force of 1.8Kg for 60 seconds.</p> 	No Visible Damage Magnification of 20X or greater may be employed for inspection of the mechanical integrity of the device body terminals and body/terminal junction.	AEC-Q200 006
Physical Dimension	Any applicable method using x10 magnification, micrometers, calipers, gauges, contour projectors, or other measuring equipment, capable of determining the actual specimen dimensions.	In accordance with specification.	JESD22 JB100



深圳福汇科技有限公司
Shenzhen Fuhui Technology Co.Ltc

Prepared by : **harry**

Designed by : **andy**

Checked by : **andy**

Approved by : **oliver**

TITLE : 3.2x1.6 x 0.5mm) WiFi/Bluetooth Ceramic Chip Antenna (YF400B) Engineering Specification

DOCUMENT NO.

FH3216D1R244501

REV.
A