

Hardware Block Diagram of TGBS900BA(Base station)

TriangleCNC Inc

Version: 1.04

Sep. 1, 2017

Hardware block diagram of TGBS900BA (Base station)

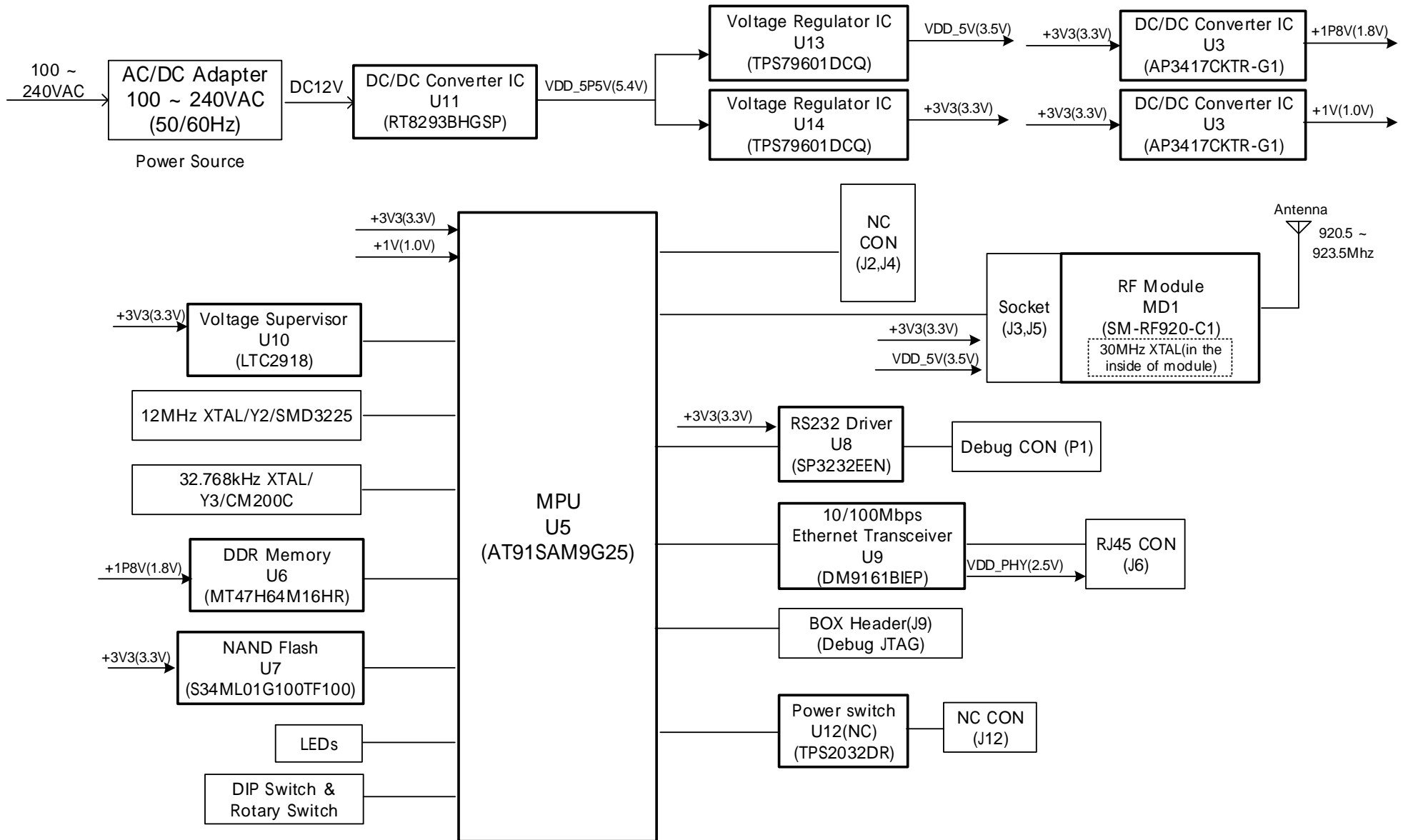

TGBS900BA(Base Station) Board Block Diagram

Hardware Block Diagram of RF Module(SM-RF920-C1)

TriangleCNC Inc

Version: 1.01

August 20, 2017

Hardware block diagram of RF module(SM-RF920-C1)

