

1. Overview

1.1 Scope of application

This ECU is designed mainly for overseas development, and is compatible with the MGT (High version) models.

2. Mechanical properties

2.1 Shape and Dimensions

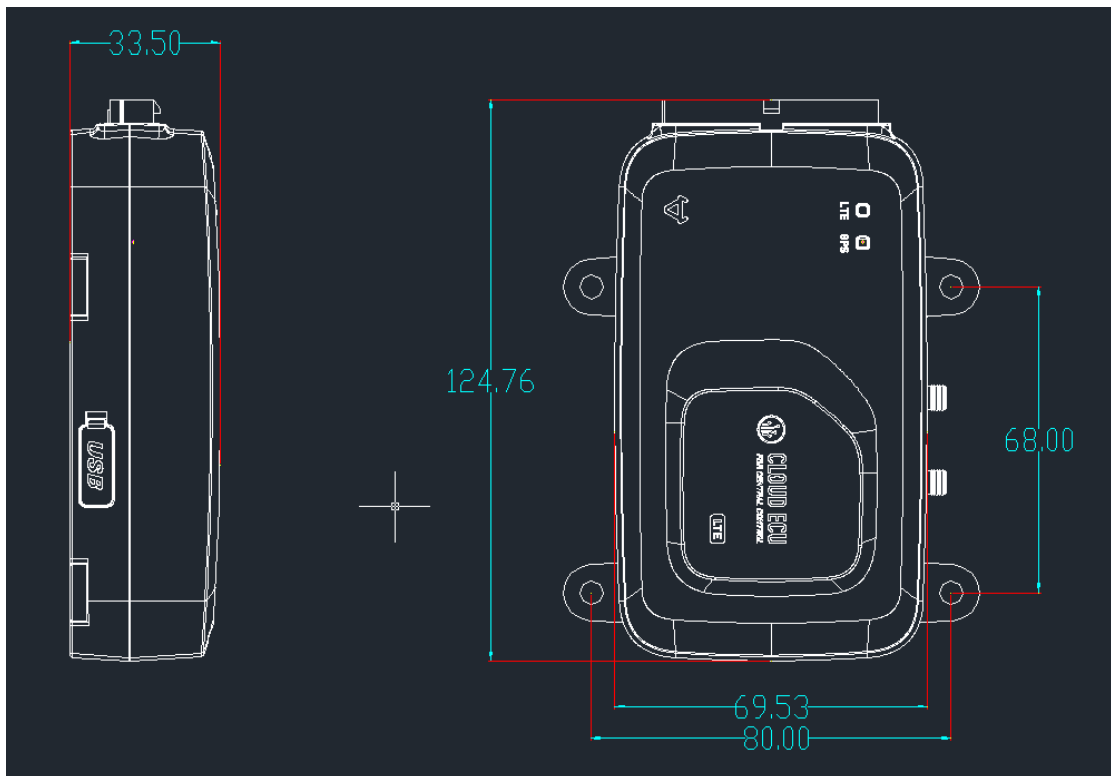

2.2 Exploded view

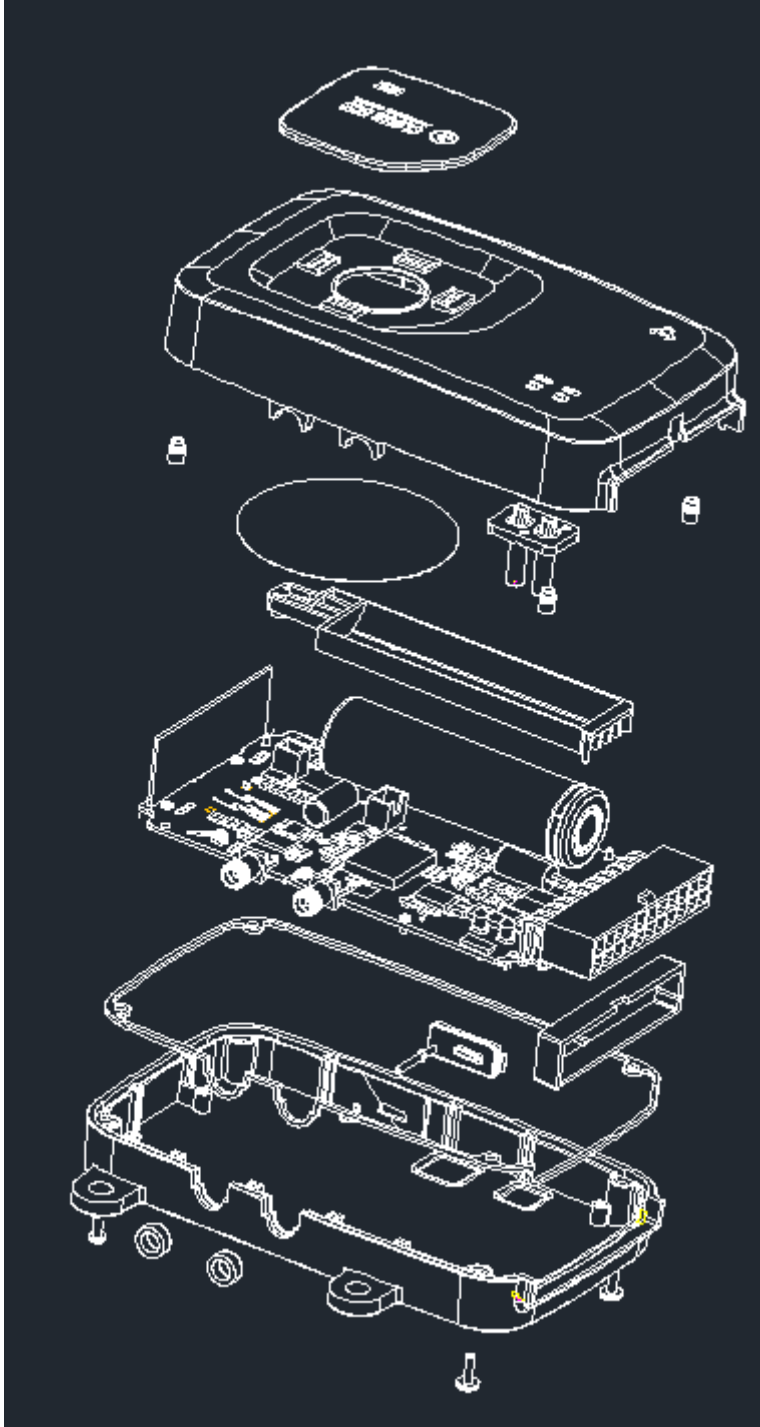

2. 3 Mechanical parameters

- Shell material, color code PP black
- PCB thickness: 1.2mm
- Type of fixing screw: black, cross recessed self-tapping screw

3 Electrical characteristics

3.1 Electrical parameters

3.1.1 power supply

Item	Value	Work scope	remark
Supply voltage	48V	36-100V	
Electric current	15mA	<200mA	48V

3.1.2 Signal

3.1.2.1 Electric door lock signal

Item	parameters
Signal type	High and low
Voltage scope	< 55V
logic	0 (0V~15V) 1 (37V~70V)
Input resistance	51K
Input current	>0.1mA
Logic trip voltage	20V

3.1.2.2 485 Circuit

Circuit diagram

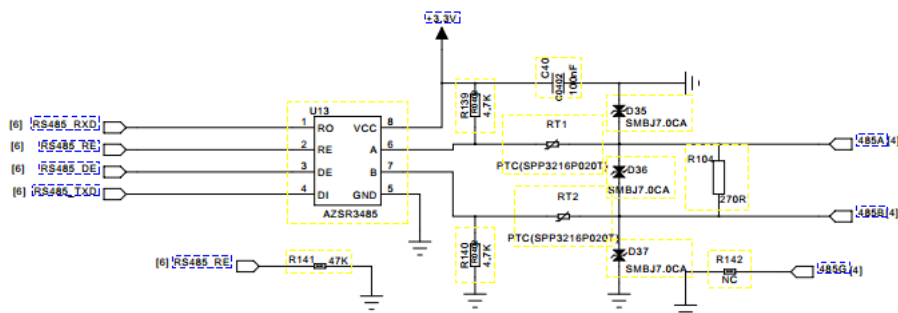

3.1.3 Battery and related circuits

3.1.3.1 Battery parameters

Item	Parameters
Nominal capacity	2200mAh
Model	18650
Rated voltage	3.7V
Charging cut-off voltage	4.2V
Discharge cut-off voltage	3V
Maximum charging current	1100mA
Standard continuous discharge current	440mA

3.1.3.2 Charging

Item	Parameters
Input power	5V
Input current	200mA
Trickle charge current	50mA
Constant current charging current	200mA
Constant voltage charging voltage	4.2V
Temperature protection	125°C

3.2 Module parameters

3.2.1 GPS Module

- Frequency range
- Supply voltage 3.3V
- Impedance 50Ω
- Gain
- Positioning time
- Cold start 40s(under open conditions)
- Hot start 5s(under open conditions)

3.2.2 4G Module

Module	LTE	UMTS	GSM
EC25-E	FDD: B1/B3/B5/B7/B8/B20 TDD: B38/B40/B41	WCDMA:B1/B5/B8	900/1800MHz
EC25-A	FDD: B2/B4/B12	WCDMA:B2/B4/B5	

3.2.3 433MHz Module

- Frequency range: central frequency band 433MHz
- Supply power voltage: 1.8~3.6V
- OOK demodulation
- Data rate: 1.0~5.0kbps
- Sensitivity: -109dBm(3.0kbps), 0.1%BER
- Receiver bandwidth: 330/200kHz
- Periodic operation (2s/3ms)

4 Features

4.1 Function Description

The ECU is the host on the vehicle, including 485 communication module, 4G communication module, GPS positioning module, ACC detection module, small battery charging module, power supply module, six-axis gyroscope module, power management module, which can realize GPS positioning, and Network communication between servers, charge and discharge management of small batteries in the central control, vehicle attitude, acceleration detection and vehicle power management.

4.2 Functional Overview

4.2.1 Interact with cloud server through 4G module

Receive remote cloud commands , Collect vehicle data, and send some or all of the data to the cloud when the event is triggered

4.2.2 Vehicle power management

The central control can directly manage the power supply of the vast majority of the equipment of the entire vehicle, and prohibit the operation of the vehicle under special circumstances such as theft

4.2.3 Motor controller control

The ECU can communicate with the motor controller through 485. When one key is started, the central control exchanges the verification code with the motor controller. If the verification code is out of date, the motor controller runs at full speed; during the driving process, the central control queries the motor controller in real time Data, and related calculations; when one-click is started, the central control uploads the motor controller serial number, and the server verifies whether the serial number is stolen through the product library.

4.2.4 BMS Control

The ECU uses different intervals to query BMS data when the vehicle is running or parking. During one-key activation, the central control uploads the BMS serial number, and the server verifies whether the serial number is stolen through the product library.

4.2.5 Display of Dashboard data

The ECU calculates the speed and mileage through the rotation speed, obtains the time through GPS and RTC, reads the SOC through BMS, and analyzes the status of BMS and motor controller, and controls the instrument to display the time, speed, mileage, SOC, driving status, and fault code.

4.2.6 Display of Charging Time

The central control judges whether to enter the charging state by current, time and BMS status, and displays the charging time on the instrument in time.

4.2.7 Low battery speed limit

When the power is less than 10%, the central control motor controller limits the speed to the first gear.

4.2.8 Remote Control Vehicle

The APP can control the central locking, unlocking, arming, disarming, starting, shutting down, car searching, alarming, etc. through the cloud remote command.

4.2.9 GPS Positioning

The ECU can be positioned through the GPS module, and obtain and upload the latitude and longitude, time, heading, positioning error, satellite data data.

4.2.10 Vehicle data transmission

The ECU can control the 4G module to transmit vehicle data to the remote server through the 4G network.

4.2.11 Transaction alarm

The ECU monitors the status of the vehicle in real-time in the parking state, and uploads the data in time when it is detected that the vehicle has fallen or moved.

4.2.12 Robbery data verification

The ECU can upload the serial number of BMS, motor controller, central control and SIM card when the electric door is opened. The server side matches the uploaded serial number with the robbery serial number. Send a car lock order.

4.2.13 Battery removal report

When the main battery is removed, the ECU uploads the battery removal information.

4.2.14 Main battery sleep

When the main battery is powered off, the ECU enters a low-power mode, controls the GPS, 4G module, and single-chip microcomputer to sleep to achieve the longest standby time.

4.2.15 A-gps

Automatically download ephemeris data to achieve seconds.

4.2.16 485 offline upgrade

Through H1 equipment, offline upgrade.

4.2.17 FOTA

Over-the-air upgrade through differential packages. Achieve faster upgrade speed.

4.2.18 Set upload template remotely

The server can arbitrarily define the rules for uploading data in the central control.

4.2.19 Update any data remotely

The server can remotely update any data in the central control data table.

4.2.20 Battery power-on prompt tone

A reminder tone is broadcast when the battery is connected to the vehicle.

4.2.21 Battery charging start tone

When the battery begins to enter the charging state, it will announce a sound.

4.2.22 Battery charging end sound

A reminder tone will be broadcast when the battery is fully charged.

4.2.23 Alarm status changes and uploads to the server actively

When the status of the alarm changes, it will actively trigger a synchronous update.

4.2.24 Shutdown without speed overtime

When ACC is turned on and there is no vehicle speed for 8 minutes, the central control controller automatically turns off ACC.

4.2.25 Bluetooth function

You can start, close, arm and release operations via Bluetooth.

4.2.26 Data storage

Server address, secret key, ESN, vibration detection threshold, mileage, low battery speed limit value data storage, alarm associated state, and will not be lost when

upgrading the version.

4.2.27 Charging is prohibited

4.2.28 The riding status does not respond to the remote control

4.2.29 Vibration detection

When vibration is detected in the central control, a vibration alarm is reported. The vibration detection threshold can be set.

4.2.30 Dump detection

Use Gsensor to determine whether the vehicle tilt exceeds 60 °, and when it exceeds 60 °, report a dump alarm.

4.2.31 Sheepfold (electronic fence)

After the electric door is closed, the central control records the latitude and longitude of the parking. When GPS wakes up, compare the distance between real-time positioning and parking latitude and longitude. When the distance exceeds the set value, an electronic fence alarm is reported.

4.2.32 Remote control to modify vibration sensitivity function

After long-pressing the start button for 5s, the 1-5 gear switches back and forth and the prompt sound.

4.2.33 Command code matching

Send commands via remote or 485, the central control enters the remote control code matching mode, press the remote control to perform code matching.

4.2.34 Battery warehouse inspection (Hall signal)

When detecting that the battery is absent, security information will be reported to the network.

4.2.35 Seat cushion detection (Hall signal)

When it is detected that the seat cushion is opened, security information will be reported to the network.

5 Status and Task Descriptions

5.1 Detailed status and description

Vehicle Status	Descriptions	4G Module	GPS	485
Ready to boot	When the remote control start-stop button is pressed, the central control will send data to the lock control and the whole machine enters the state of ready to start.			The ECU sends a command to the lock control(LKU) to make the LKU enter the ready-to-start state. 30s after entering the ready-to-start state, if the central control detects that the faucet lock is open at this time, it will power on, if it does not detect that the faucet lock is open after 30S, the central control will issue a command to the lock control to let the lock control exit the preparation Power on state.
Illegal electric door opened	After arming, if you don't press the remote control start-stop button, if you open the faucet lock directly, it will alarm.			
Power on	Motor controller serial number and central control verification	Upload vehicle serial number information (MEI, telephone number, motor controller serial number, BMS serial number, central control serial number)	Turn on	Communicate with the motor controller, query the serial number of the motor controller once every 100ms, check with the CRC algorithm after success, enter the main program after success, communicate with the BMS and motor controller, and obtain data.
Driving	Real-time query data, display instrument	Upload location information to the server every 5s and vehicle information every 60s	Turn on	Communicate with a device every 100ms (a total of 300ms is required for the instrument, motor controller, and BMS to complete a cycle).
Power off	After shutting down through the faucet lock, the central control will save the mileage and report the status	Upload vehicle status data	Turn on 90s before sending data, then turn off	Save mileage, clear the status bits of BMS and motor controller (see protocol for details)

parking	With	P	Real-time monitoring, reporting vehicle status and location	When not sending data, the 4G module enters low power consumption mode and exits low power consumption mode each time data is sent. Turn on the first 4h, then upload location information every 5min, and upload vehicle information every 15min.	Turn on	It communicates with the BMS every 5 minutes in the first 2 hours, and every 15 minutes thereafter.
		Alar	When proactively alarming, upload data quickly	Upload location information every 6s	Turn on	
		Tran	Anti-theft / reminder (when the electric door lock is closed, the central control is moved or dumped)	When dumping, the data is continuously uploaded 5 times every 15 minutes. When moving, it is detected that the data is uploaded once.	Turn on	
		Write	Communicate with the host computer through the data line	The state remains unchanged. After writing the data, the central control starts the network function and uploads the data.	Turn on	Become slave state. Can communicate with quality inspection software, production line software, and boot upgrade software.
		Remove	sleep	Lowest power consumption operation, guarantee the longest running time	Upload location information every 15min, then close	Turn on 60s after wake up, then turn off

5.2 Data upload frequency

Vehicle Status	Send Frequency	GPS switch
ACC ON	GPS data: 5 seconds, system data: 10 seconds	Keep on
ACC OFF	GPS data: 600 seconds, system data: 1200 seconds	Close after the data upload is completed, open the GPS 120s before uploading the data
Transaction alarm status	GPS data: 3 seconds, system data: none	Keep on
Alarm state	Alarm status changes, upload immediately, then 3 seconds	Turn on the GPS when you touch the alarm. After the alarm is over, restore the previous time setting
Pull out the battery alarm	GPS data 900 seconds; system data: none	After the central control wakes up, turn on for 60 seconds

5.3 Communication protocol

5.3.1 In-vehicle communication 485 communication protocol see, "Maverick Electric Communication Protocol", "Controller Command Table", "BMS Communication Protocol", "Instrument Communication Protocol"

5.3.2 For the network communication protocol, please refer to "Definition of Central Control Data Exchange"

5.4 Abnormal state

5.4.1 When the other electronic equipment of the vehicle is in an abnormal state, the central control instrument displays the fault code.

5.4.2 No card inserted, the central control setting instrument displays 60, and always displays

5.4.3 The SIM card is in arrears, the central control setting instrument displays 67, and the screen is cleared after 2S.

5.4.4 After being in the position without GPS signal for a long time, and the central control is completely powered off, the central control cannot get the correct time accurately.

5.4.5 Input overvoltage, undervoltage will cause the central control to burn out, or the power supply cannot be normally supplied

5.5 Light effect description

	Blue Light	Green Light	Blue and green light always on
Always on	Do not connect to the Internet	Positing Failure	Do not have SIM card
Always off	No such status	GPS closed	
Flash fast	No configuration file written (high priority)		100ms on, 1s off
Flash slow	Build internet	Positing success	100ms on, 3s off

5.6 Instrument icon effect description



GSM Icon	
L02 always on L2 on	Strong signal, signal>10
L02 always on L2 flash	Weak signal, signal 1~9
L02 flash L2 off	No signal, 0

GPS Icon	
L01 always on L1 on	Strong signal, signal >3
L01 always on L1 flash	Weak signal, signal 1~2
L01 flash L1 off	No signal, 0

6 Alarm and power management functions and sound and light effects

6.1 Description of vehicle status

Mode	Entry conditions	Perform action
Parking	<ol style="list-style-type: none"> 1. Turn on the faucet lock and enter 2. Enter by command 	<ol style="list-style-type: none"> 1. Play stop sound; 2. Turn off the 48V power output; 3. Cancel two 48V signal output; 4. Automatically enter arming state after 10s (automatic arming function)
Fortification	<ol style="list-style-type: none"> 1. 10S automatically enters from the end of the parking mode (automatic defense function) 2. In parking mode, press the remote control arming key to enter 3. When in parking mode, enter by command 	<ol style="list-style-type: none"> 1. Play a lock tone; 2. Flashing left and right turn signal prompts;
Unlock	<ol style="list-style-type: none"> 1. Under the defense state, press the remote control release key to enter 2. In the state of fortification, enter through the command 	<ol style="list-style-type: none"> 1. Play unlock tone; 2. Flashing left and right turn signal prompts; 3. Cancel two 48V signal outputs and turn off 48V power output at the same time
Start	<ol style="list-style-type: none"> 1. In other modes besides the start mode, press the start-stop button of the remote control to enter the ready-to-start state, and start the faucet lock within 30S 	<ol style="list-style-type: none"> 1. Play the start sound; 2. Enable two 48V signal outputs, turn on 48V power output at the same time, cancel the motor lock and phase
Search	<ol style="list-style-type: none"> 1. Enter by command 	<ol style="list-style-type: none"> 1. Blink left and right turn signal to prompt 10s, and then play car search sound for 20s
Vibration alarm	<ol style="list-style-type: none"> 1. Under the state of fortification, illegally touch the vehicle 2. Enter by command 	<ol style="list-style-type: none"> 1. Play the alarm tone and flash the left and right turn lights to alarm; 2. Enable the 48V signal output of the control machine, and at the same time lock the motor signal enable, lock the motor and cancel another 48V signal output; 3. Turn off the 48V power output; 4. Cancel the above 3 items 10 seconds after the alarm is cleared; 5. Exit the alarm mode by command during the alarm; 6. Press the remote control release button during the alarm to exit the alarm mode;

Wheel alarm	<p>1. In the fortified state, the hub rotation triggers</p> <p>* Note: The wheel motion alarm detects the motor phase input signal. When the hub is stationary, the motor phase signal does not change. After the lock motor signal is enabled, the motor phase signal fluctuates, and the phase signal detection should be stopped</p>	<ol style="list-style-type: none"> 1. Play the alarm tone and flash the left and right turn lights to alarm; 2. Enable the 48V signal output of the control machine, and at the same time lock the motor signal enable, lock the motor and cancel another 48V signal output; 3. Turn off the 48V power output; 4. Cancel the above 3 items 10 seconds after the alarm is cleared; 5. Exit the alarm mode by command during the alarm 6. Press the remote control release button during the alarm to exit the alarm mode
Illegal electric door opened Call the police	<p>1. Under the fortified state, the mechanical electric door lock is triggered to open</p>	<ol style="list-style-type: none"> 1. Play the alarm tone and flash the left and right turn lights to alarm; 2. Enable the 48V signal output of the control machine, and at the same time lock the motor signal enable, lock the motor and cancel another 48V signal output; 3. Turn off the 48V power output; 4. Cancel the above 3 items 10 seconds after the alarm is cleared; 5. Exit the alarm mode by command during the alarm

6.2 Sound effect definition

Name	Description
Start tone	1kHz 0.05s + pause 0.04s + 1.35kHz-0.05s + pause 0.04s + 1.55kHz 0.05s
Parking sound	1.55kHz 0.05s + pause 0.02s + 1.35kHz 0.05s + pause 0.02s + 1kHz 0.05s
Lock tone	1kHz 0.05s + 1.5kHz 0.05s + 1kHz 0.05s;
Unlock tone	(1kHz 0.05s + 1.2kHz 0.05s + 1.2kHz 0.05s + pause 0.1s) Loop 2 times;
Search tone	(1.5kHz 0.05s + 1kHz 0.05s + 1.5kHz 0.05s + pause 0.1s) loop: (Once double flash once)
Alarm tone	(1.5kHz 0.05s + 1kHz 0.05s + 1.5kHz 0.05s + pause 0.1s) Loop 20 times;
Operation prompt tone	(1kHz 0.05s + pause 0.03s) Loop 2 times

6.3 Lighting definition

Status	Left/right turn light	Headlight / tail lights	Buzzer sound effect
Fortification	Turns off after 3s	Turns off after 3s	The same as the sound effect of the specification
Disarm	Flashes 2 times at 1s intervals and goes off	Turns off after 2s	The same as the sound effect of the specification

Vibration / wheel alarm	Flashes 10 times at 1s intervals and goes off	Steady off after 10s	The same as the sound effect of the specification, stop after 10s
Search	Blink 20 times at 1s intervals, off	Turns off after 20s	There is no sound in the first 10s, and the sound effect in the second 10s is the same as the specification, and the 10s stops
Turn on	off	off	The same as the sound effect of the specification
Turn off	off	off	The same as the sound effect of the specification

7 Notes on OTA upgrade function

When using H1 or other tools for OTA offline upgrade, please close the door lock to operate, otherwise it will cause unpredictable failure.

8 Performance requirements

8.1 Temperature

-20 ~ + 50 °C, the central control unit can run continuously for a long time

-30 ~ + 80 °C, the central control unit can store for a long time

8.2 Humidity

It can work normally when the relative humidity does not exceed 100%. The central control unit should work safely when the surface temperature is lower than the dew point, even if condensation occurs on the surface.

8.3 Salt spray

Meet the relevant regulations in GB / T2423.17.

8.4 Fixed frequency vibration and sweep frequency vibration

Fix the central control unit on the vibration test platform, and perform the vibration test according to the conditions specified in the table below. During the test, there shall be no loose or damaged parts. The performance is intact after the test.

Frequency sweep range (Hz)	Double amplitude (mm)	Frequency sweep	Period (min)
10~25	1.5	16	45

8.5 Waterproof and dustproof

When raining or high-pressure water washing, the construction, installation and ventilation of the central control unit shall ensure that it will not be damaged. The central control unit shall meet the protection level requirements of IP54 products in GB / T 4942.2.

8.6 Temperature insulation resistance

In the dry environment, the insulation resistance of the central control unit is not less than 20MΩ.

8.7 Constant damp heat

The central control unit should be able to withstand a constant humid heat test at $40\text{ }^{\circ}\text{C} \pm 2\text{ }^{\circ}\text{C}$, a relative humidity of 90% to 95% and a duration of 4 days. The appearance should be free of obvious corrosion and spots, the functions of the central control unit should be normal, the insulation resistance should not be less than 1 MΩ, and should comply with the provisions of e, f of this chapter.

8.8 Electrostatic discharge immunity

The table shall comply with the Class B classification specified in GB / T 17626.2.

8.9 Electromagnetic compatibility

Meet GB / T18655-2002, GB / T17619-1998.

This device complies with part 15 of the FCC Rules. Operation is subject to the condition that this device does not cause harmful interference.

This device is verified to comply with part 15 of the FCC Rules for use with cable television service.

This device complies with part 15 of the FCC Rules. Operation is subject to the following two conditions:

- (1) This device may not cause harmful interference, and*
- (2) this device must accept any interference received, including interference that may cause undesired operation.*

Please note that changes or modifications not expressly approved by the party responsible for compliance could void the user's authority to operate the equipment.

Note: This equipment has been tested and found to comply with the limits for a Class B digital device, pursuant to part 15 of the FCC Rules. These limits are designed to provide reasonable protection against harmful interference in a residential installation. This equipment generates, uses and can radiate radio frequency energy and, if not installed and used in accordance with the instructions, may cause harmful interference to radio communications. However, there is no guarantee that interference will not occur in a particular installation. If this equipment does cause harmful interference to radio or television reception, which can be determined by turning the equipment off and on, the user is encouraged to try to correct the interference by one or more of the following measures:

- Reorient or relocate the receiving antenna.*
- Increase the separation between the equipment and receiver.*
- Connect the equipment into an outlet on a circuit different from that to which the receiver is connected.*
- Consult the dealer or an experienced radio/TV technician for help.*

This equipment complies with radio frequency exposure limits set forth by the FCC for an uncontrolled environment.

*This equipment should be installed and operated with a minimum distance of **20 cm** between the device and the user or bystanders.*

This device must not be co-located or operating in conjunction with any other antenna or transmitter.