

FCC CFR47 PART 24E, 27 CERTIFICATION TEST REPORT FCC ID: 2AQ8SPRIMEA1PRO

Product: Mobile Phone
Trade Mark: Easyfone
Model Number: Prime-A1 Pro
Family Model: N/A
Report No.: STR210915001004E

Prepared for

Shen Zhen Yixun Electronic Technology Co., Ltd.
14D, HuaqiaoXinyuan, WanzhongCity, Xinniu Community, Minzhi St., Longhua
Dist., Shenzhen, Guangdong, China

Prepared by

Shenzhen NTEK Testing Technology Co., Ltd.
1/F, Building E, Fenda Science Park, Sanwei Community, Xixiang Street
Bao'an District, Shenzhen 518126 P.R. China
Tel. 400-800-6106, 0755-2320 0050, 0755-2320 0090
Website:<http://www.ntek.org.cn>

TEST RESULT CERTIFICATION

Applicant's name	Shen Zhen Yixun Electronic Technology Co., Ltd.
Address	14D, HuaqiaoXinyuan, WanzhongCity, Xinniu Community, Minzhi St., Longhua Dist., Shenzhen, Guangdong, China
Manufacturer's Name	Shen Zhen Yixun Electronic Technology Co., Ltd.
Address	14D, HuaqiaoXinyuan, WanzhongCity, Xinniu Community, Minzhi St., Longhua Dist., Shenzhen, Guangdong, China
Product name.....	Mobile Phone
Model and/or type reference ...:	Prime-A1 Pro
Family Model:	N/A
Standards	FCC CFR 47 Part 24E, Part 27
Test procedure	ANSI C63.26:2015 ANSI/TIA-603-E-2016

This device described above has been tested by NTEK, and the test results show that the equipment under test (EUT) is in compliance with the FCC requirements. And it is applicable only to the tested sample identified in the report.

This report shall not be reproduced except in full, without the written approval of NTEK, this document may be altered or revised by NTEK, personal only, and shall be noted in the revision of the document.

Date of Test	
Date (s) of performance of tests	Sep 15, 2021 ~Oct 26, 2021
Date of Issue	Oct 26, 2021
Test Result	Pass

Testing Engineer : 

 (Mary Hu)

Authorized Signatory : 

 (Alex Li)

TABLE OF CONTENTS

1. GENERAL INFORMATION	6
1.1 PRODUCT DESCRIPTION	6
1.2 RELATED SUBMITTAL(S) / GRANT (S).....	6
1.3 TEST METHODOLOGY.....	6
1.4 TEST FACILITY.....	7
MEASUREMENT UNCERTAINTY	7
1.5 SPECIAL ACCESSORIES.....	7
1.6 WORST-CASE CONFIGURATION AND MODE.....	7
1.6 SUMMARY OF TEST RESULTS	8
2. SYSTEM TEST CONFIGURATION	9
2.1 EUT CONFIGURATION.....	9
2.2 EUT EXERCISE	9
2.3 CONFIGURATION OF EUT SYSTEM.....	9
2.4 TEST SETUP	10
3.TEST AND MEASUREMENT EQUIPMENT	11
4. OUTPUT POWER.....	13
4.1 OUTPUT POWER MEASUREMENT	13
6. BANEDGE AND EMISSION MASK	16
7. OUT OF BAND EMISSIONS.....	17
7.1 MEASUREMENT METHOD	18
8. RADIATED MEASUREMENT	19
8.1. RADIATED POWER (ERP & EIRP).....	19
8.2 LTE BAND 2	20
8.3 LTE BAND 4	24
9. SPURIOUS RADIATION EMISSION	28

9.1 LTE BAND 2 30
9.2 LTE BAND 4 32
10. FREQUENCY STABILITY 34
10.1 LTE BAND 2 35
10.2 LTE BAND 4 37
11. PEAK-TO-AVERAGE RATIO 39
11.1 Description of the PAR Measurement 39
11.2 Measuring Instruments 39
11.3 Test Procedures 39
11.4 Test Setup 39

1. GENERAL INFORMATION

1.1 PRODUCT DESCRIPTION

A major technical description of EUT is described as following:

Product Designation:	Mobile Phone
Trade Mark	Easyfone
Model Name	Prime-A1 Pro
Family Model	N/A
Model Difference	N/A
FCC ID:	2AQ8SPRIMEA1PRO
Frequency Bands:	U.S. Bands: <input checked="" type="checkbox"/> LTE FDD Band 2, 4
Frequency Range:	LTE FDD Band 2 Uplink: 1850MHz-1910MHz, Downlink: 1930MHz-1990MHz; LTE FDD Band 4 Uplink: 1710MHz-1755MHz, Downlink: 2110MHz-2155MHz;
Type of Modulation:	QPSK/16QAM
Power Class	Class 3
Antenna:	FPC Antenna
Antenna gain:	0.5dBi
Power Supply:	DC 3.7V, 1500mAh,5.55Wh from battery or DC 5V from Adapter.
Adapter:	Model: ES007-U050055XOF Input: AC 100-240V~50/60Hz 0.3A Output: DC 5.0V---0.55A
Extreme Vol. Limits:	DC 3.2V to DC 4.2V (Nominal DC 3.7V) (Note 1)
HW Version	GS052 V1.0
SW Version	GS052-Easyfone-Prime-A1-4G-20210830-LC-V1.02
** Note1: The High Voltage 4.2V and Low Voltage 3.2V was declared by manufacturer, The EUT couldn't be operate normally with higher or lower voltage.	

1.2 RELATED SUBMITTAL(S) / GRANT (S)

This submittal(s) (test report) is intended for **FCC ID: 2AQ8SPRIMEA1PRO** filing to comply with the FCC Part 24E &27.

1.3 TEST METHODOLOGY

The tests documented in this report were performed in accordance with ANSI/TIA-603-E-2016, FCC CFR 47 Part 2, Part 24, Part 27, ANSI C63.26:2015.

1.4 TEST FACILITY

The test site used to collect the radiated data is located at:

ShenZhen NTEK Testing Technology Co., Ltd.

1/F, Building E, Fenda Science Park, Sanwei Community, Xixiang Street, Bao'an District, Shenzhen 518126 P.R.China.

The test site is constructed and calibrated to meet the FCC requirements in documents ANSI C63.26:2015& ANSI C63.4: 2014.

FCC Registration No.:463705

IC Registration No.:9270A-1,

CNAS Registration No.:L5516

MEASUREMENT UNCERTAINTY

The reported uncertainty of measurement, where expended uncertainty U is based on a standard uncertainty multiplied by a coverage factor of k=2, providing a level of confidence of approximately 95 %.

No.	Item	Uncertainty
1	Measuring Uncertainty for a Level of Confidence of 95% ($U = 2Uc(y)$)	2.5dB
2	Conducted Emission Test	± 1.38 dB
3	RF power, conducted	± 0.16 dB
4	Spurious emissions, conducted	± 0.21 dB
5	All emissions, radiated(<1G)	± 4.68 dB
6	All emissions, radiated(>1G)	± 4.89 dB
7	Temperature	± 0.5 °C
8	Humidity	± 2 %
9	Frequency error, conducted	± 0.19 ppm

1.5 SPECIAL ACCESSORIES

The battery and the charger, earphone supplied by the applicant were used as accessories and being tested with EUT intended for FCC grant together.

1.6 WORST-CASE CONFIGURATION AND MODE

The worst-case scenario for all measurements is based on the investigation results.

The device has LTE Bands of: Band 2, Band 4

The RB Size was selected to measure for peak or average ERP and EIRP, which was based on the conducted power verification baseline data.

For the fundamental investigation of radiated emissions, the EUT is investigated for vertical and horizontal antenna orientations and X Y and Z orientations of the EUT alone. After the investigations the worst case was determined to be at X orientation for all LTE bands.

1.6 SUMMARY OF TEST RESULTS

FCC Part24, Subpart E, FCC Part27, Subpart L, KDB 971168 D01 Power Meas License Digital Systems v03			
FCC Rule	Test Item	Verdict	Remark
2.1046	Conducted Output Power	PASS	
24.232(d) 27.50(d)(5) KDB 971168 D01 Clause 5.7	Peak-to-Average Ratio	PASS	
2.1049 24.238(b) KDB 971168 D01 Clause 4.2	Occupied Bandwidth	PASS	
2.1051 24.238(a) 27.53(h) KDB 971168 D01 Clause 6	Band Edge	PASS	
24.232(c) 27.50 (d)(4) KDB 971168 D01 Clause 5.6	Equivalent Isotropic Radiated Power	PASS	
2.1053 24.238(a) 27.53 (h) KDB 971168 D01 Clause 7	Field Strength of Spurious Radiation	PASS	
2.1055 24.235 27.54 KDB 971168 D01 Clause 9	Frequency Stability for Temperature & Voltage	PASS	
2.1051 24.238(a) 27.53 (h) KDB 971168 D01 Clause 6	Conducted Emission	PASS	
<p>Remark:</p> <ol style="list-style-type: none"> 1. "N/A" denotes test is not applicable in this Test Report. 2. All test items were verified and recorded according to the standards and without any deviation during the test. 3. No modifications are made to the EUT during all test items. 			

2. SYSTEM TEST CONFIGURATION

2.1 EUT CONFIGURATION

The EUT configuration for testing is installed on RF field strength measurement to meet the Commission's requirement and operating in a manner which intends to maximize its emission characteristics in a continuous normal application.

2.2 EUT EXERCISE

The Transmitter was operated in the maximum output power mode through Communication Tester. The TX frequency was fixed which was for the purpose of the measurements.

2.3 CONFIGURATION OF EUT SYSTEM

Table 2-1 Equipment Used in EUT System

Item	Equipment	Model No.	ID or Specification	Note
1	Mobile Phone	Prime-A1 Pro	FCC ID: 2AQ8SPRIMEA1PRO	EUT

*Note: All the accessories have been used during the test.
the following "EUT" in setup diagram means EUT system.*

2.4 TEST SETUP

For Radiated Test Cases

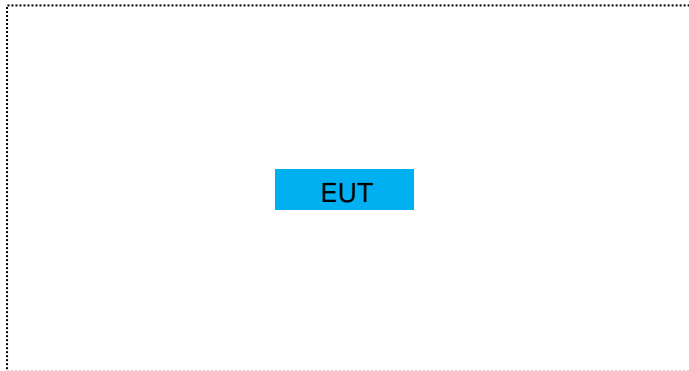

For Conducted Output Power

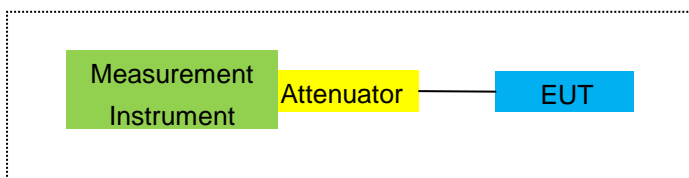

For Peak-to Average Ratio, Occupied Bandwidth, Conducted Band edge and Conducted Spurious Emission

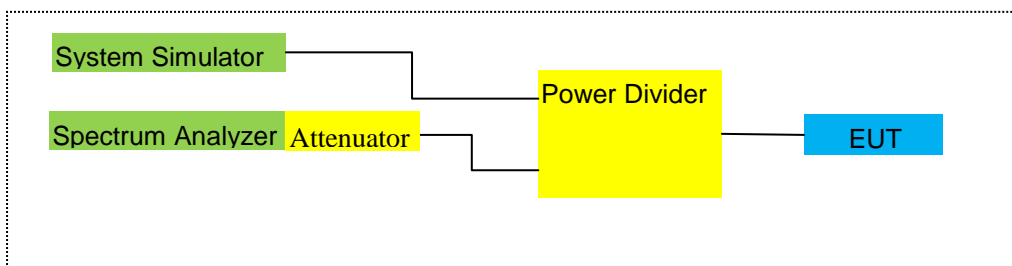

For Frequency Stability

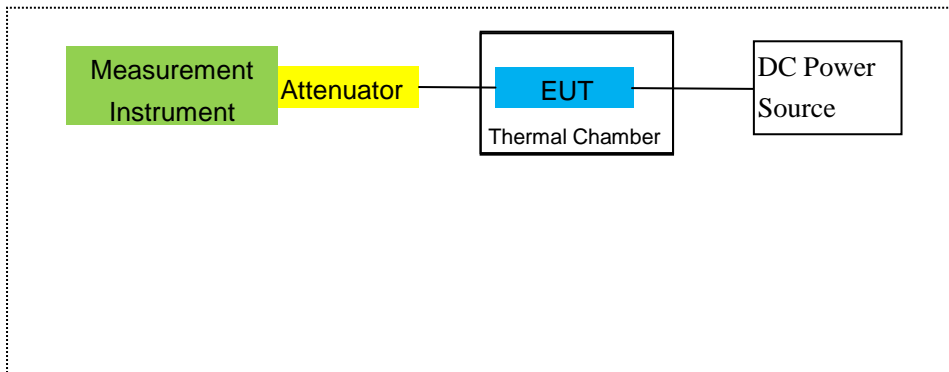

Note: EUT built-in battery-powered, the battery is fully-charged.

3. TEST AND MEASUREMENT EQUIPMENT

The following test and measurement equipment was utilized for the tests documented in this report:

Item	Kind of Equipment	Manufacturer	Type No.	Serial No.	Last calibration	Calibrated until	Calibration period
1	MXA Signal Analyzer	Agilent	N9020A	MY49100060	2021.07.01	2022.06.30	1 year
2	Test Receiver	R&S	ESPI	101318	2021.04.27	2022.04.26	1 year
3	Bilog Antenna	TESEQ	CBL6111D	31216	2021.03.29	2022.03.28	1 year
4	50Ω Coaxial Switch	Anritsu	MP59B	6200983705	2020.05.11	2023.05.10	3 year
5	Horn Antenna	EM	EM-AH-10180	2011071402	2021.03.29	2022.03.28	1 year
6	Horn Ant	Schwarzbeck	BBHA 9170	9170-181	2020.11.20	2021.11.19	1 year
7	Amplifier	EM	EM-30180	060538	2021.07.01	2022.06.30	1 year
8	Loop Antenna	ARA	PLA-1030/B	1029	2021.04.27	2022.04.26	1 year
9	Power Meter	R&S	NRVS	100696	2021.07.01	2022.06.30	1 year
10	Power Sensor	R&S	URV5-Z4	0395.1619.05	2021.04.27	2022.04.26	1 year
11	Test Cable	N/A	R-01	N/A	2019.08.06	2022.08.05	3 year
12	Test Cable	N/A	R-02	N/A	2019.08.06	2022.08.05	3 year
13	Test Cable	N/A	R-03	N/A	2019.06.28	2022.06.27	3 year
14	Test Receiver	R&S	ESCI	101160	2021.04.27	2022.04.26	1 year
15	LISN	R&S	ENV216	101313	2021.04.27	2022.04.26	1 year
16	LISN	EMCO	3816/2	00042990	2021.04.27	2022.04.26	1 year
17	50Ω Coaxial Switch	Anritsu	MP59B	6200264417	2021.04.27	2022.04.26	1 year
18	Passive Voltage Probe	R&S	ESH2-Z3	100196	2021.04.27	2022.04.26	1 year
19	Test Cable	N/A	C01	N/A	2020.05.11	2023.05.10	3 year
20	Test Cable	N/A	C02	N/A	2020.05.11	2023.05.10	3 year
21	Test Cable	N/A	C03	N/A	2020.05.11	2023.05.10	3 year
22	Attenuator	MCE	24-10-34	BN9258	2020.05.11	2021.05.10	1 year
23	Spectrum Analyzer	agilent	e4440a	us44300399	2021.04.27	2022.04.26	1 year
24	test receiver	R&S	ESCI	a0304218	2021.04.27	2022.04.26	1 year
25	Communication Tester	R&S	CMU200	A0304247	2021.07.01	2022.06.30	1 year
26	Thermal Chamber	Ten Billion	TTC-B3C	TBN-960502	2021.04.27	2022.04.26	1 year

27	DC Power Source	N/A	PS-6005D	2017040292 3	2020.05.11	2023.05.10	3 year
28	PSG Analog Signal Generator	Agilent	E8257D	MY51110112	2021.07.01	2022.06.30	1 year
29	Communication Tester	R&S	CMW500	148500	2021.07.01	2022.06.30	1 year
30	PSG Analog Signal Generator	Agilent	E8257D	MY51110112	2021.07.01	2022.06.30	1 year

Note: Each piece of equipment is scheduled for calibration once a year except the Test Cable& DC Power Source which is scheduled for calibration every 3 years.

4. OUTPUT POWER

4.1 OUTPUT POWER MEASUREMENT

LTE Measurement Procedure:

All LTE bands conducted power peak and average are obtained from the CMW500 telecommunication test set. The following tests were conducted according to the test requirements outlined in section 6.2 of the 3GPP TS36.101 specification.

UE Power Class: 3 (23 +/- 2dBm). The allowed Maximum Power Reduction (MPR) for the maximum output power due to higher order modulation and transmit bandwidth configuration (resource blocks) is specified in Table 6.2.3-1 of the 3GPP TS36.101.

Table 6.2.3-1: Maximum Power Reduction (MPR) for Power Class 3

Modulation	Channel bandwidth / Transmission bandwidth (RB)						MPR (dB)
	1.4 MHz	3.0 MHz	5 MHz	10 MHz	15 MHz	20 MHz	
QPSK	> 5	> 4	> 8	> 12	> 16	> 18	≤ 1
16 QAM	≤ 5	≤ 4	≤ 8	≤ 12	≤ 16	≤ 18	≤ 1
16 QAM	> 5	> 4	> 8	> 12	> 16	> 18	≤ 2

The allowed A-MPR values specified below in Table 6.2.4.-1 of 3GPP TS36.101 are in addition to the allowed MPR requirements. All the measurements below were performed with A-MPR disabled, by using Network Signaling Value of "NS_01".3

Table 6.2.4-1: Additional Maximum Power Reduction (A-MPR)

Network Signalling value	Requirements (sub-clause)	E-UTRA Band	Channel bandwidth (MHz)	Resources Blocks (N_{RB})	A-MPR (dB)
NS_01	6.6.2.1.1	Table 5.5-1	1.4, 3, 5, 10, 15, 20	Table 5.6-1	NA
NS_03	6.6.2.2.1	2, 4, 10, 23, 25, 35, 36	3	>5	≤ 1
			5	>6	≤ 1
			10	>6	≤ 1
			15	>8	≤ 1
			20	>10	≤ 1
NS_04	6.6.2.2.2	41	5	>6	≤ 1
			10, 15, 20	See Table 6.2.4-4	
NS_05	6.6.3.3.1	1	10, 15, 20	≥ 50	≤ 1
NS_06	6.6.2.2.3	12, 13, 14, 17	1.4, 3, 5, 10	Table 5.6-1	n/a
NS_07	6.6.2.2.3	13	10	Table 6.2.4-2	Table 6.2.4-2
	6.6.3.3.2				
NS_08	6.6.3.3.3	19	10, 15	> 44	≤ 3
NS_09	6.6.3.3.4	21	10, 15	> 40	≤ 1
				> 55	≤ 2
NS_10		20	15, 20	Table 6.2.4-3	Table 6.2.4-3
NS_11	6.6.2.2.1	23 ¹	1.4, 3, 5, 10	Table 6.2.4-5	Table 6.2.4-5
..					
NS_32	-	-	-	-	-

Note 1: Applies to the lower block of Band 23, i.e. a carrier placed in the 2000-2010 MHz region.

Test data reference attachment.

5. OCCUPIED BANDWIDTH

RULE PART(S)

FCC: §2.1049

LIMITS

For reporting purposes only

TEST PROCEDURE

The transmitter output was connected to a calibrated coaxial cable and coupler, the other end of which was connected to a spectrum analyzer. The occupied bandwidth was measured with the spectrum analyzer at the low, middle and high channel in each band. The -26dB bandwidth was also measured and recorded.

MODES TESTED

- LTE Band 2
- LTE Band 4

RESULTS

PASS

Test data reference attachment.

6. BANDEDGE AND EMISSION MASK

RULE PART(S)

FCC: §2.1051, §24.238(a), §27.53(h)

FCC: §2.1046, §24.232

LIMITS

The minimum permissible attenuation level of any spurious emission is $43 + \log_{10}(P[\text{Watts}])$, where P is the transmitter power in Watts.

The minimum permissible attenuation level for Band 7 is as following.

Per 27.53(g) for operations in the 698-746 MHz band, in the 100 kHz bands immediately outside and adjacent to the frequency block a resolution bandwidth of at least 30 kHz may be employed to demonstrate compliance with the out-of-band emissions limit.

Per 27.53(c.5) for operations in the 776-788 MHz band, in the 100 kHz bands immediately outside and adjacent to the frequency block a resolution bandwidth of at least 30 kHz may be employed to demonstrate compliance with the out-of-band emissions limit.

For all plots showing emissions in the 763 – 775MHz and 793 – 805MHz band, the FCC limit per 27.53(c.4) is $65 + 10\log_{10}(P) = -35\text{dBm}$ in a 6.25kHz bandwidth.

Per 27.53(m) for operations in the BRS/EBS bands, the attenuation factor shall be not less than $40 + 10 \log (P)$ dB on all frequencies between the channel edge and 5 megahertz from the channel edge, $43 + 10 \log (P)$ dB on all frequencies between 5 megahertz and X megahertz from the channel edge, and $55 + 10 \log (P)$ dB on all frequencies more than X megahertz from the channel edge, where X is the greater of 6 megahertz or the actual emission bandwidth.

TEST PROCEDURE

The transmitter output was connected to a CMW500Test Set and configured to operate at maximum power. The band edge emissions were measured at the required operating frequencies in each band on the Spectrum Analyzer.

For each band edge measurement:

Set the spectrum analyzer span to include the block edge frequency

Set a marker to point the corresponding band edge frequency in each test case.

Set display line

Set resolution bandwidth to at least 1% of emission bandwidth.

MODES TESTED

- LTE Band 2/4

RESULTS

Test data reference attachment.

7. OUT OF BAND EMISSIONS

RULE PART(S)

FCC: §2.1051, §24.238(a), §27.53 (h)

LIMITS

The minimum permissible attenuation level of any spurious emission is $43 + \log_{10}(P[\text{Watts}])$, where P is the transmitter power in Watts.

The minimum permissible attenuation level for Band 7 is as following.

Per 27.53(g) for operations in the 698-746 MHz band, in the 100 kHz bands immediately outside and adjacent to the frequency block a resolution bandwidth of at least 30 kHz may be employed to demonstrate compliance with the out-of-band emissions limit.

Per 27.53(c.5) for operations in the 776-788 MHz band, in the 100 kHz bands immediately outside and adjacent to the frequency block a resolution bandwidth of at least 30 kHz may be employed to demonstrate compliance with the out-of-band emissions limit.

For all plots showing emissions in the 763 – 775MHz and 793 – 805MHz band, the FCC limit per 27.53(c.4) is $65 + 10\log_{10}(P) = -35\text{dBm}$ in a 6.25kHz bandwidth.

Per 27.53(m) for operations in the BRS/EBS bands, the attenuation factor shall be not less than $40 + 10 \log (P)$ dB on all frequencies between the channel edge and 5 megahertz from the channel edge, $43 + 10 \log (P)$ dB on all frequencies between 5 megahertz and X megahertz from the channel edge, and $55 + 10 \log (P)$ dB on all frequencies more than X megahertz from the channel edge, where X is the greater of 6 megahertz or the actual emission bandwidth.

TEST PROCEDURE

The RF output of the transmitter was connected to a spectrum analyzer through a calibrated coaxial cable. Sufficient scans were taken to show the out-of-band Emissions, if any, up to 10th harmonic. Multiple sweeps were recorded in maximum hold mode using a peak detector to ensure that the worst-case emissions were caught.

For each out of band emissions measurement:

- Set display line
- Set RBW & VBW to 100 kHz for the measurement below 1 GHz, and 1 MHz for the measurement above 1 GHz.

MODES TESTED

- LTE Band2
- LTE Band 4

7.1 MEASUREMENT METHOD

The test set up and general procedure is similar to conducted peak output power test. Only different for setting the measurement configuration of the measuring instrument of Spectrum Analyzer.

Test data reference attachment.

Note: For LTE band 2/4, the frequency range above the 5th harmonic, the amplitude of spurious emission that is attenuated by more than 20dB below the permissible limit has no need to be reported.

8. RADIATED MEASUREMENT

8.1. RADIATED POWER (ERP & EIRP)

RULE PART(S)

FCC: §2.1046, §24.232(c) and §27.50 (d)(4)

LIMITS:

- 22.913(a) (2)- The ERP of mobile transmitters and auxiliary test transmitters must not exceed 7 Watts.
- 24.232 (c) Mobile and portable stations are limited to 2 watts EIRP.
- 27.50 (c) (10) the following power and antenna height requirements apply to stations transmitting in the 698–746 MHz band, the portable stations (hand-held devices) are limited to 3 watts ERP.
- 27.50 (b)(10) Portable stations (hand-held devices) transmitting in the 746–757 MHz, 758–763 MHz, 776–793 MHz, and 805–806 MHz bands are limited to 3 watts ERP.
- 27.50 (d)(4) The following power and antenna height requirements apply to stations transmitting in the 1710–1755 MHz and 2110–2155 MHz bands: Fixed, mobile, and portable (hand-held) stations operating in the 1710–1755 MHz band are limited to 1 watt EIRP.
- 27.50 (h)(2) Mobile and other user stations in the 2500–2570 MHz and 2620–2690 MHz bands. Mobile stations are limited to 2.0 watts EIRP. All user stations are limited to 2.0 watts transmitter output power.

TEST PROCEDURE

ANSI/TIA-603-E Clause 2.2.17

KDB 971168 v02r01 RF power output using broadband peak and average power meter method.

KDB 971168 D01 Power Meas License Digital Systems v02r01, “Measurement Guidance for Certification of Licensed Digital Transmitters”

MODES TESTED

- LTE Band2
- LTE Band 4

RESULTS

Pass

8.2 LTE BAND 2

Radiated Power (EIRP) for Band 2									
Mode	RB/RB SIZE	Frequency	Result					Polarization Of Max. ERP	Conclusion
			SG Level (dBm)	Cable Loss (dBm)	Antenna Gain (dB)	Max. EIRP Average (dBm)	Max. EIRP		
							Average (mW)		
1.4MHz Band QPSK	1/#Mid	1850.7	-2.09	3.76	28.24	22.39	173.38	Horizontal	Pass
		1880	-0.56	3.91	28.22	23.75	237.14	Horizontal	Pass
		1909.3	0.55	3.93	28.20	24.82	303.39	Horizontal	Pass
3.0MHz Band QPSK	1/#Mid	1851.5	-1.05	3.77	28.23	23.41	219.28	Horizontal	Pass
		1880	-1.27	3.91	28.24	23.06	202.30	Horizontal	Pass
		1908.5	-0.69	3.94	28.25	23.62	230.14	Horizontal	Pass
5.0MHz Band QPSK	1/#Mid	1852.5	-0.99	3.77	28.31	23.55	226.46	Horizontal	Pass
		1880	0.18	3.91	28.22	24.49	281.19	Horizontal	Pass
		1907.5	-3.95	3.94	28.20	20.31	107.40	Horizontal	Pass
10.0MHz Band QPSK	1/#Mid	1855	-3.82	3.79	28.33	20.72	118.03	Horizontal	Pass
		1880	-2.28	3.95	28.22	21.99	158.12	Horizontal	Pass
		1905	-0.41	3.97	28.19	23.81	240.44	Horizontal	Pass
15.0MHz Band QPSK	1/#Mid	1857.5	-1.37	3.79	28.34	23.18	207.97	Horizontal	Pass
		1880	0.30	3.95	28.22	24.57	286.42	Horizontal	Pass
		1902.5	-0.57	3.97	28.18	23.64	231.21	Horizontal	Pass
20.0MHz Band QPSK	1/#Mid	1860	-2.11	3.81	28.35	22.43	174.98	Horizontal	Pass
		1880	-0.53	3.96	28.22	23.73	236.05	Horizontal	Pass
		1900	-0.76	4.00	28.16	23.40	218.78	Horizontal	Pass
1.4MHz Band QPSK	1/#Mid	1850.7	-1.67	3.76	28.24	22.81	190.99	Vertical	Pass
		1880	-0.63	3.91	28.22	23.68	233.35	Vertical	Pass
		1909.3	-1.85	3.93	28.20	22.42	174.58	Vertical	Pass
3.0MHz Band QPSK	1/#Mid	1851.5	-0.54	3.77	28.23	23.92	246.60	Vertical	Pass
		1880	-0.53	3.91	28.24	23.80	239.88	Vertical	Pass
		1908.5	-1.44	3.94	28.25	22.87	193.64	Vertical	Pass
5.0MHz Band QPSK	1/#Mid	1852.5	-1.81	3.77	28.31	22.73	187.50	Vertical	Pass
		1880	0.80	3.91	28.22	25.11	324.34	Vertical	Pass
		1907.5	-0.41	3.94	28.20	23.85	242.66	Vertical	Pass
10.0MHz Band QPSK	1/#Mid	1855	-2.51	3.79	28.33	22.03	159.59	Vertical	Pass
		1880	-1.77	3.95	28.22	22.50	177.83	Vertical	Pass
		1905	-0.97	3.97	28.19	23.25	211.35	Vertical	Pass
15.0MHz Band QPSK	1/#Mid	1857.5	-0.04	3.79	28.34	24.51	282.49	Vertical	Pass
		1880	-0.47	3.95	28.22	23.80	239.88	Vertical	Pass
		1902.5	1.02	3.97	28.18	25.23	333.43	Vertical	Pass

20.0MHz		1860	1.15	3.81	28.35	25.69	370.68	Vertical	Pass
Band	1/#Mid	1880	1.72	3.96	28.22	25.98	396.28	Vertical	Pass
QPSK		1900	1.85	4.00	28.16	26.01	399.02	Vertical	Pass

Note:

SG Level= Signal generator output

Max. EIRP Average (dBm)= Antenna Gain(dB)+ SG Level (dBm)- Cable Loss(dBm)

Radiated Power (EIRP) for Band 2										
Mode	RB/RB SIZE	Frequency	Result					Max. EIRP Average (mW)	Polarization Of Max. ERP	Conclusion
			SG Level (dBm)	Cable Loss (dBm)	Antenna Gain (dB)	Max. EIRP Average (dBm)	Max. EIRP			
1.4MHz Band 16 QAM	1/#Mid	1850.7	-1.46	3.76	28.24	23.02	200.45	Horizontal	Pass	
		1880	-0.22	3.91	28.22	24.09	256.45	Horizontal	Pass	
		1909.3	-2.51	3.93	28.20	21.76	149.97	Horizontal	Pass	
3.0MHz Band 16 QAM	1/#Mid	1851.5	-2.46	3.77	28.23	22	158.49	Horizontal	Pass	
		1880	-2.05	3.91	28.24	22.28	169.04	Horizontal	Pass	
		1908.5	-1.90	3.94	28.25	22.41	174.18	Horizontal	Pass	
5.0MHz Band 16 QAM	1/#Mid	1852.5	-3.13	3.77	28.31	21.41	138.36	Horizontal	Pass	
		1880	-1.41	3.91	28.22	22.9	194.98	Horizontal	Pass	
		1907.5	-0.99	3.94	28.20	23.27	212.32	Horizontal	Pass	
10.0MHz Band 16 QAM	1/#Mid	1855	-0.29	3.79	28.33	24.25	266.07	Horizontal	Pass	
		1880	-0.55	3.95	28.22	23.72	235.50	Horizontal	Pass	
		1905	0.96	3.97	28.19	25.18	329.61	Horizontal	Pass	
15.0MHz Band 16 QAM	1/#Mid	1857.5	0.12	3.79	28.34	24.67	293.09	Horizontal	Pass	
		1880	-1.22	3.95	28.22	23.05	201.84	Horizontal	Pass	
		1902.5	-1.83	3.97	28.18	22.38	172.98	Horizontal	Pass	
20.0MHz Band 16 QAM	1/#Mid	1860	-1.11	3.81	28.35	23.43	220.29	Horizontal	Pass	
		1880	-0.15	3.96	28.22	24.11	257.63	Horizontal	Pass	
		1900	-0.57	4.00	28.16	23.59	228.56	Horizontal	Pass	
1.4MHz Band 16 QAM	1/#Mid	1850.7	-2.12	3.76	28.24	22.36	172.19	Vertical	Pass	
		1880	-0.23	3.91	28.22	24.08	255.86	Vertical	Pass	
		1909.3	-1.66	3.93	28.20	22.61	182.39	Vertical	Pass	
3.0MHz Band 16 QAM	1/#Mid	1851.5	-0.07	3.77	28.23	24.39	274.79	Vertical	Pass	
		1880	0.82	3.91	28.24	25.15	327.34	Vertical	Pass	
		1908.5	-0.50	3.94	28.25	23.81	240.44	Vertical	Pass	
5.0MHz Band 16 QAM	1/#Mid	1852.5	-1.67	3.77	28.31	22.87	193.64	Vertical	Pass	
		1880	-3.86	3.91	28.22	20.45	110.92	Vertical	Pass	
		1907.5	-3.13	3.94	28.20	21.13	129.72	Vertical	Pass	
10.0MHz Band 16 QAM	1/#Mid	1855	0.85	3.79	28.33	25.39	345.94	Vertical	Pass	
		1880	-2.40	3.95	28.22	21.87	153.82	Vertical	Pass	
		1905	1.01	3.97	28.19	25.23	333.43	Vertical	Pass	
15.0MHz Band 16 QAM	1/#Mid	1857.5	-0.46	3.79	28.34	24.09	256.45	Vertical	Pass	
		1880	-0.98	3.95	28.22	23.29	213.30	Vertical	Pass	
		1902.5	0.98	3.97	28.18	25.19	330.37	Vertical	Pass	

20.0MHz		1860	-1.00	3.81	28.35	23.54	225.94	Vertical	Pass
Band 16	1/#Mid	1880	1.69	3.96	28.22	25.95	393.55	Vertical	Pass
QAM		1900	-1.91	4.00	28.16	22.25	167.88	Vertical	Pass

Note:

SG Level= Signal generator output

Max. EIRP Average (dBm)= Antenna Gain(dB)+ SG Level (dBm)- Cable Loss(dBm)

8.3 LTE BAND 4

Radiated Power (EIRP) for Band 4									
Mode	RB/RB SIZE	Frequency	Result					Polarization Of Max. ERP	Conclusion
			SG Level (dBm)	Cable Loss (dBm)	Antenna Gain (dB)	Max. EIRP	Max. EIRP		
						Average (dBm)	Average (mW)		
1.4MHz Band QPSK	1/#Mid	1710.7	-0.15	3.12	27.58	24.31	269.77	Horizontal	Pass
		1732.5	-1.23	3.27	27.61	23.11	204.64	Horizontal	Pass
		1754.3	1.13	3.29	27.63	25.47	352.37	Horizontal	Pass
3.0MHz Band QPSK	1/#Mid	1711.5	-0.64	3.13	27.61	23.84	242.10	Horizontal	Pass
		1732.5	-0.58	3.27	27.61	23.76	237.68	Horizontal	Pass
		1753.5	0.26	3.30	27.62	24.58	287.08	Horizontal	Pass
5.0MHz Band QPSK	1/#Mid	1712.5	0.85	3.13	27.63	25.35	342.77	Horizontal	Pass
		1732.5	-0.31	3.27	27.61	24.03	252.93	Horizontal	Pass
		1752.5	0.95	3.30	27.60	25.25	334.97	Horizontal	Pass
10.0MHz Band QPSK	1/#Mid	1715	0.18	3.15	27.64	24.67	293.09	Horizontal	Pass
		1732.5	0.62	3.31	27.61	24.92	310.46	Horizontal	Pass
		1750	0.58	3.33	27.59	24.84	304.79	Horizontal	Pass
15.0MHz Band QPSK	1/#Mid	1717.5	-0.94	3.15	27.65	23.56	226.99	Horizontal	Pass
		1732.5	-0.50	3.31	27.61	23.8	239.88	Horizontal	Pass
		1747.5	-0.19	3.33	27.57	24.05	254.10	Horizontal	Pass
20.0MHz Band QPSK	1/#Mid	1720	-0.59	3.17	27.66	23.9	245.47	Horizontal	Pass
		1732.5	-0.56	3.32	27.61	23.73	236.05	Horizontal	Pass
		1745	0.15	3.36	27.56	24.35	272.27	Horizontal	Pass
1.4MHz Band QPSK	1/#Mid	1710.7	0.44	3.12	27.58	24.9	309.03	Vertical	Pass
		1732.5	0.08	3.27	27.61	24.42	276.69	Vertical	Pass
		1754.3	0.67	3.29	27.63	25.01	316.96	Vertical	Pass
3.0MHz Band QPSK	1/#Mid	1711.5	-0.01	3.13	27.61	24.47	279.90	Vertical	Pass
		1732.5	-0.36	3.27	27.61	23.98	250.03	Vertical	Pass
		1753.5	-0.26	3.30	27.62	24.06	254.68	Vertical	Pass
5.0MHz Band QPSK	1/#Mid	1712.5	0.10	3.13	27.63	24.6	288.40	Vertical	Pass
		1732.5	0.99	3.27	27.61	25.33	341.19	Vertical	Pass
		1752.5	0.82	3.30	27.60	25.12	325.09	Vertical	Pass
10.0MHz Band QPSK	1/#Mid	1715	-0.43	3.15	27.64	24.06	254.68	Vertical	Pass
		1732.5	0.19	3.31	27.61	24.49	281.19	Vertical	Pass
		1750	0.85	3.33	27.59	25.11	324.34	Vertical	Pass
15.0MHz Band QPSK	1/#Mid	1717.5	0.08	3.15	27.65	24.58	287.08	Vertical	Pass
		1732.5	0.27	3.31	27.61	24.57	286.42	Vertical	Pass
		1747.5	-0.23	3.33	27.57	24.01	251.77	Vertical	Pass

20.0MHz		1720	1.08	3.17	27.66	25.57	360.58	Vertical	Pass
Band	1/#Mid	1732.5	1.49	3.32	27.61	25.78	378.44	Vertical	Pass
QPSK		1745	0.19	3.36	27.56	24.39	274.79	Vertical	Pass

Note:

SG Level= Signal generator output

Max. EIRP Average (dBm)= Antenna Gain(dB)+ SG Level (dBm)- Cable Loss(dBm)

Radiated Power (EIRP) for Band 4									
Mode	RB/RB SIZE	Frequency	Result					Polarization Of Max. ERP	Conclusion
			SG Level	Cable Loss (dBm)	Antenna Gain (dB)	Max. EIRP	Max. EIRP		
			(dBm)			Average	Average		
						(dBm)	(mW)		
1.4MHz Band 16 QAM	1/#Mid	1710.7	0.05	3.12	27.58	24.51	282.49	Horizontal	Pass
		1732.5	-0.33	3.27	27.61	24.01	251.77	Horizontal	Pass
		1754.3	-0.50	3.29	27.63	23.84	242.10	Horizontal	Pass
3.0MHz Band 16 QAM	1/#Mid	1711.5	-0.57	3.13	27.61	23.91	246.04	Horizontal	Pass
		1732.5	1.12	3.27	27.61	25.46	351.56	Horizontal	Pass
		1753.5	0.95	3.30	27.62	25.27	336.51	Horizontal	Pass
5.0MHz Band 16 QAM	1/#Mid	1712.5	0.71	3.13	27.63	25.21	331.89	Horizontal	Pass
		1732.5	0.21	3.27	27.61	24.55	285.10	Horizontal	Pass
		1752.5	-0.20	3.30	27.60	24.10	257.04	Horizontal	Pass
10.0MHz Band 16 QAM	1/#Mid	1715	0.66	3.15	27.64	25.15	327.34	Horizontal	Pass
		1732.5	-0.92	3.31	27.61	23.38	217.77	Horizontal	Pass
		1750	-0.28	3.33	27.59	23.98	250.03	Horizontal	Pass
15.0MHz Band 16 QAM	1/#Mid	1717.5	0.52	3.15	27.65	25.02	317.69	Horizontal	Pass
		1732.5	-0.77	3.31	27.61	23.53	225.42	Horizontal	Pass
		1747.5	-0.91	3.33	27.57	23.33	215.28	Horizontal	Pass
20.0MHz Band 16 QAM	1/#Mid	1720	0.35	3.17	27.66	24.84	304.79	Horizontal	Pass
		1732.5	-0.17	3.32	27.61	24.12	258.23	Horizontal	Pass
		1745	0.64	3.36	27.56	24.84	304.79	Horizontal	Pass
1.4MHz Band 16 QAM	1/#Mid	1710.7	1.16	3.12	27.58	25.62	364.75	Vertical	Pass
		1732.5	0.13	3.27	27.61	24.47	279.90	Vertical	Pass
		1754.3	1.13	3.29	27.63	25.47	352.37	Vertical	Pass
3.0MHz Band 16 QAM	1/#Mid	1711.5	0.91	3.13	27.61	25.39	345.94	Vertical	Pass
		1732.5	0.69	3.27	27.61	25.03	318.42	Vertical	Pass
		1753.5	1.01	3.30	27.62	25.33	341.19	Vertical	Pass
5.0MHz Band 16 QAM	1/#Mid	1712.5	0.75	3.13	27.63	25.25	334.97	Vertical	Pass
		1732.5	0.87	3.27	27.61	25.21	331.89	Vertical	Pass
		1752.5	0.46	3.30	27.60	24.76	299.23	Vertical	Pass
10.0MHz Band 16 QAM	1/#Mid	1715	1.05	3.15	27.64	25.54	358.10	Vertical	Pass
		1732.5	0.33	3.31	27.61	24.63	290.40	Vertical	Pass
		1750	1.27	3.33	27.59	25.53	357.27	Vertical	Pass
15.0MHz Band 16 QAM	1/#Mid	1717.5	1.02	3.15	27.65	25.52	356.45	Vertical	Pass
		1732.5	-0.44	3.31	27.61	23.86	243.22	Vertical	Pass
		1747.5	0.48	3.33	27.57	24.72	296.48	Vertical	Pass

20.0MHz		1720	-0.30	3.17	27.66	24.19	262.42	Vertical	Pass
Band 16	1/#Mid	1732.5	1.39	3.32	27.61	25.68	369.83	Vertical	Pass
QAM		1745	0.92	3.36	27.56	25.12	325.09	Vertical	Pass

Note:

SG Level= Signal generator output

Max. EIRP Average (dBm)= Antenna Gain(dB)+ SG Level (dBm)- Cable Loss(dBm)

9. SPURIOUS RADIATION EMISSION

RULE PART(S)

FCC: §2.1051, §24.238(a), §27.53 (h)

LIMIT

For Band 7, the minimum permissible attenuation level of any spurious emission is $55 + \log_{10}(P)$ [Watts]).

The minimum permissible attenuation level of any spurious emission is $43 + \log_{10}(P)$ [Watts]), where P is the transmitter power in Watts.

TEST PROCEDURE

For Cellular equipment - Compliance with these rules is based on the use of measurement instrumentation employing a resolution bandwidth of 100 kHz or greater. In the 1 MHz bands immediately outside and adjacent to the frequency block a resolution bandwidth of at least one percent of the emission bandwidth of the fundamental emission of the transmitter may be employed. A narrower resolution bandwidth is permitted in all cases to improve measurement accuracy provided the measured power is integrated over the full required measurement bandwidth (i.e. 100 kHz or 1 percent of emission bandwidth, as specified). The emission bandwidth is defined as the width of the signal between two points, one below the carrier center frequency and one above the carrier center frequency, outside of which all emissions are attenuated at least 26 dB below the transmitter power.

For PCS equipment - Compliance with these rules is based on the use of measurement instrumentation employing a resolution bandwidth of 1 MHz or greater. However, in the 1 MHz bands immediately outside and adjacent to the frequency block a resolution bandwidth of at least one percent of the emission bandwidth of the fundamental emission of the transmitter may be employed. A narrower resolution bandwidth is permitted in all cases to improve measurement accuracy provided the measured power is integrated over the full required measurement bandwidth (i.e. 1 MHz or 1 percent of emission bandwidth, as specified). The emission bandwidth is defined as the width of the signal between two points, one below the carrier center frequency and one above the carrier center frequency, outside of which all emissions are attenuated at least 26 dB below the transmitter power.

The unwanted emission power shall be measured with a resolution bandwidth of at least 1% of the occupied bandwidth in the 1 MHz band immediately outside and adjacent to the channel edge of the equipment. Beyond the 1 MHz band immediately outside the channel edge of the equipment, a resolution bandwidth of 1 MHz shall be employed. A narrower resolution bandwidth is allowed to be used provided that the measured power is integrated over the full required measurement bandwidth of 1 MHz or 1% of the occupied bandwidth as applicable.

The power of any unwanted emissions measured from the channel edge of the equipment shall be attenuated below the transmitter power, P (dBW), as follows:

- a. for base station and subscriber equipment, other than mobile subscriber equipment, the attenuation shall not be less than $43 + 10 \text{ Log}_{10} (p)$, dB; and
- b. for mobile subscriber equipment, the attenuation shall not be less than $43 + 10 \text{ Log}_{10} (p)$, dB at the channel edges and $55 + 10 \text{ Log}_{10} (p)$ at 5.5 MHz away and beyond the channel edges where p in (a) and (b) is the transmitter power measured in watts.

MODES TESTED

- LTE Band 2
LTE Band 4
-

RESULTS

PASS

9.1 LTE BAND 2

QPSK EIRP POWER FOR LTE BAND 2 (1.4MHZ BANDWIDTH)

Test Results for Low Channel 1850.7MHz							
Frequency(MHz)	SG Level(dBm)	Cable Loss(dB)	Antenna Gain(dB)	Absolute Level(dBm)	Limit (dBm)	Margin(dBm)	Polarity
3701.4	-51.40	4.04	33.51	-21.93	-13	-8.93	Horizontal
3701.4	-50.92	4.04	33.51	-21.45	-13	-8.45	Vertical
5552.1	-55.04	5.24	35.84	-24.44	-13	-11.44	Vertical
5552.1	-65.13	5.24	35.84	-34.53	-13	-21.53	Horizontal
Test Results for Mid Channel 1880MHz							
3760	-51.30	4.04	33.56	-21.78	-13	-8.78	Horizontal
3760	-53.08	4.04	33.56	-23.56	-13	-10.56	Vertical
5640	-52.04	5.24	35.91	-21.37	-13	-8.37	Vertical
5640	-52.59	5.24	35.91	-21.92	-13	-8.92	Horizontal
Test Results for High Channel 1909.3MHz							
3818.6	-51.72	4.04	34.00	-21.76	-13	-8.76	Horizontal
3818.6	-52.44	4.04	34.00	-22.48	-13	-9.48	Vertical
5727.9	-57.30	5.24	36.04	-26.50	-13	-13.50	Vertical
5727.9	-54.40	5.24	36.04	-23.60	-13	-10.60	Horizontal

QPSK EIRP POWER FOR LTE BAND 2 (20.0MHZ BANDWIDTH)

Test Results for Low Channel 1860MHz							
Frequency(MHz)	SG Level(dBm)	Cable Loss(dB)	Antenna Gain(dB)	Absolute Level(dBm)	Limit (dBm)	Margin(dBm)	Polarity
3720	-54.11	4.07	33.54	-24.64	-13	-11.64	Horizontal
3720	-50.40	4.07	33.54	-20.93	-13	-7.93	Vertical
5580	-55.57	5.28	35.86	-24.99	-13	-11.99	Vertical
5580	-58.84	5.28	35.86	-28.26	-13	-15.26	Horizontal
Test Results for Mid Channel 1880MHz							
3760	-54.60	4.04	33.56	-25.08	-13	-12.08	Horizontal
3760	-49.87	4.04	33.56	-20.35	-13	-7.35	Vertical
5640	-55.08	5.24	35.91	-24.41	-13	-11.41	Vertical
5640	-55.93	5.24	35.91	-25.26	-13	-12.26	Horizontal
Test Results for High Channel 1900MHz							
3800	-51.50	4.04	34.00	-21.54	-13	-8.54	Horizontal
3800	-54.99	4.04	34.00	-25.03	-13	-12.03	Vertical
5700	-56.35	5.24	36.04	-25.55	-13	-12.55	Vertical
5700	-55.33	5.24	36.04	-24.53	-13	-11.53	Horizontal

Note: $P_{Mea}(dBm) = Power(dBm) + ARpl (dBm)$

Over Limit = $P_{Mea}(dBm) - Limit(dBm)$

Both QPSK and 16QAM has been tested, the worst case is QPSK mode, the report just reported the worst case.

9.2 LTE BAND 4

QPSK EIRP POWER FOR LTE BAND 4 (1.4MHZ BANDWIDTH)

Test Results for Low Channel 1710.7MHz							
Frequency(MHz)	SG Level(dBm)	Cable Loss(dB)	Antenna Gain(dB)	Absolute Level(dBm)	Limit (dBm)	Margin(dBm)	Polarity
3421.4	-55.94	4.02	29.80	-30.16	-13	-17.16	Horizontal
3421.4	-55.11	4.02	29.80	-29.33	-13	-16.33	Vertical
5132.1	-58.61	5.24	35.84	-28.01	-13	-15.01	Vertical
5132.1	-61.52	5.24	35.84	-30.92	-13	-17.92	Horizontal
Test Results for Mid Channel 1732.5MHz							
3465	-48.04	4.03	30.00	-22.07	-13	-9.07	Horizontal
3465	-51.79	4.03	30.00	-25.82	-13	-12.82	Vertical
5197.5	-53.76	5.25	35.86	-23.15	-13	-10.15	Vertical
5197.5	-54.20	5.25	35.86	-23.59	-13	-10.59	Horizontal
Test Results for High Channel 1754.3MHz							
3508.6	-48.12	4.05	30.01	-22.16	-13	-9.16	Horizontal
3508.6	-58.42	4.05	30.01	-32.46	-13	-19.46	Vertical
5262.9	-56.98	5.26	35.86	-26.38	-13	-13.38	Vertical
5262.9	-52.63	5.26	35.86	-22.03	-13	-9.03	Horizontal

QPSK EIRP POWER FOR LTE BAND 4 (20.0MHZ BANDWIDTH)

Test Results for Low Channel 1710.7MHz							
Frequency(MHz)	SG Level(dBm)	Cable Loss(dB)	Antenna Gain(dB)	Absolute Level(dBm)	Limit (dBm)	Margin(dBm)	Polarity
3440	-54.57	4.02	29.80	-28.79	-13	-15.79	Horizontal
3440	-55.86	4.02	29.80	-30.08	-13	-17.08	Vertical
5160	-58.03	5.24	35.84	-27.43	-13	-14.43	Vertical
5160	-61.31	5.24	35.84	-30.71	-13	-17.71	Horizontal
Test Results for Mid Channel 1732.5MHz							
3465	-48.33	4.03	30.00	-22.36	-13	-9.36	Horizontal
3465	-54.02	4.03	30.00	-28.05	-13	-15.05	Vertical
5197.5	-58.03	5.25	35.86	-27.42	-13	-14.42	Vertical
5197.5	-55.14	5.25	35.86	-24.53	-13	-11.53	Horizontal
Test Results for High Channel 1754.3MHz							
2490	-51.64	2.91	27.68	-26.87	-13	-13.87	Horizontal
3490	-53.94	2.91	27.68	-29.17	-13	-16.17	Vertical
5235	-56.95	5.26	35.86	-26.35	-13	-13.35	Vertical
5235	-56.21	5.26	35.86	-25.61	-13	-12.61	Horizontal

Note: $P_{Mea}(dBm) = Power(dBm) + ARpl(dBm)$

. Over Limit = $P_{Mea}(dBm) - Limit(dBm)$

. Both QPSK and 16QAM has been tested, the worst case is QPSK mode, the report just reported the worst case.

10. FREQUENCY STABILITY

RULE PART(S)

FCC: §2.1055, §24.235, §27.54

LIMITS

§24.235 - The frequency stability shall be sufficient to ensure that the fundamental emission stays within the authorized frequency block.

TEST PROCEDURE

Use CMW 500 with Frequency Error measurement capability.

- Temp. = -30° to +50°C
- Voltage =low voltage,DC 3.3V, Normal, DC 3.7V and High voltage, DC 4.2V.

Frequency Stability vs Temperature:

The EUT is place inside a temperature chamber. The temperature is set to -30°C and allowed to stabilize. After sufficient soak time, the transmitting frequency error is measured. The temperature is increased by 10 degrees, allowed to stabilize and soak, and then the measurement is repeated. This is repeated until +50°C is reached.

Frequency Stability vs Voltage:

The peak frequency error is recorded (worst-case).

MODES TESTED

- LTE Band 2
- LTE Band 4
-

RESULTS

See the following pages.

10.1 LTE BAND 2

Band 2 QPSK, (20MHz BANDWIDTH RB size 100 RB Offset 0)

Frequency error vs. Voltage

Voltage [Vdc]	Frequency [MHz]	Frequency* Error[Hz]	Frequency Error[ppm]	Limit [ppm]
3.2	1880	24	0.01277	2.5
3.7	1880	29	0.01543	2.5
4.2	1880	21	0.01117	2.5

Frequency error vs. Temperature

Temperature [° C]	Frequency [MHz]	Frequency* Error[Hz]	Frequency Error[ppm]	Limit [ppm]
Normal (25C)	1880	17	0.00904	2.5
Extreme (50C)	1880	13	0.00691	2.5
Extreme (40C)	1880	17	0.00904	2.5
Extreme (30C)	1880	13	0.00691	2.5
Extreme (10C)	1880	15	0.00798	2.5
Extreme (0C)	1880	18	0.00957	2.5
Extreme (-10C)	1880	14	0.00745	2.5
Extreme (-20C)	1880	16	0.00851	2.5
Extreme (-30C)	1880	12	0.00638	2.5

Band 2 16QAM, (20MHz BANDWIDTH RB size 100 RB Offset 0)

Frequency error vs. Voltage

Voltage [Vdc]	Frequency [MHz]	Frequency* Error[Hz]	Frequency Error[ppm]	Limit [ppm]
3.2	1880	18	0.00957	2.5
3.7	1880	26	0.01383	2.5
4.2	1880	14	0.00745	2.5

Frequency error vs. Temperature

Temperature [° C]	Frequency [MHz]	Frequency* Error[Hz]	Frequency Error[ppm]	Limit [ppm]
Normal (25C)	1880	12	0.00638	2.5
Extreme (50C)	1880	13	0.00691	2.5
Extreme (40C)	1880	14	0.00745	2.5
Extreme (30C)	1880	11	0.00585	2.5
Extreme (10C)	1880	12	0.00638	2.5
Extreme (0C)	1880	10	0.00532	2.5
Extreme (-10C)	1880	13	0.00691	2.5
Extreme (-20C)	1880	12	0.00638	2.5
Extreme (-30C)	1880	10	0.00532	2.5

*Note: Frequency error measurements were made by using the build-in capability of the Wireless Communication Test Set.

10.2 LTE BAND 4

Band 4 QPSK, (20MHz BANDWIDTH RB size 100 RB Offset 0)

Frequency error vs. Voltage

Voltage [Vdc]	Frequency [MHz]	Frequency* Error[Hz]	Frequency Error[ppm]	Limit [ppm]
3.2	1732.5	31	0.01789	2.5
3.7	1732.5	16	0.00924	2.5
4.2	1732.5	24	0.01385	2.5

Frequency error vs. Temperature

Temperature [°C]	Frequency [MHz]	Frequency* Error[Hz]	Frequency Error[ppm]	Limit [ppm]
Normal (25C)	1732.5	21	0.01212	2.5
Extreme (50C)	1732.5	28	0.01616	2.5
Extreme (40C)	1732.5	22	0.01270	2.5
Extreme (30C)	1732.5	20	0.01154	2.5
Extreme (10C)	1732.5	29	0.01674	2.5
Extreme (0C)	1732.5	26	0.01501	2.5
Extreme (-10C)	1732.5	24	0.01385	2.5
Extreme (-20C)	1732.5	27	0.01558	2.5
Extreme (-30C)	1732.5	23	0.01328	2.5

Band 4 16QAM, (20MHz BANDWIDTH RB size 100 RB Offset 0)

Frequency error vs. Voltage

Voltage [Vdc]	Frequency [MHz]	Frequency* Error[Hz]	Frequency Error[ppm]	Limit [ppm]
3.2	1732.5	28	0.01616	2.5
3.7	1732.5	32	0.01847	2.5
4.2	1732.5	29	0.01674	2.5

Frequency error vs. Temperature

Temperature [°C]	Frequency [MHz]	Frequency* Error[Hz]	Frequency Error[ppm]	Limit [ppm]
Normal (25C)	1732.5	26	0.01501	2.5
Extreme (50C)	1732.5	24	0.01385	2.5
Extreme (40C)	1732.5	23	0.01328	2.5
Extreme (30C)	1732.5	27	0.01558	2.5
Extreme (10C)	1732.5	23	0.01328	2.5
Extreme (0C)	1732.5	20	0.01154	2.5
Extreme (-10C)	1732.5	28	0.01616	2.5
Extreme (-20C)	1732.5	27	0.01558	2.5
Extreme (-30C)	1732.5	23	0.01328	2.5

***Note:** Frequency error measurements were made by using the build-in capability of the Wireless Communication Test Set.

11. Peak-to-Average Ratio

11.1 Description of the PAR Measurement

The peak-to-average ratio (PAR) of the transmission may not exceed 13 dB.

11.2 Measuring Instruments

See list of measuring instruments of this test report.

11.3 Test Procedures

1. The EUT was connected to Spectrum Analyzer and Base Station via power divider.
2. The RF output of EUT was connected to the spectrum analyzer by RF cable and attenuator. The path loss was compensated to the results for each measurement.
3. For LTE operating modes:
 - a. Set the CCDF (Complementary Cumulative Distribution Function) option in spectrum analyzer.
 - b. The highest RF powers were measured and recorded the maximum PAPR level associated with a probability of 0.1 %.

11.4 Test Setup

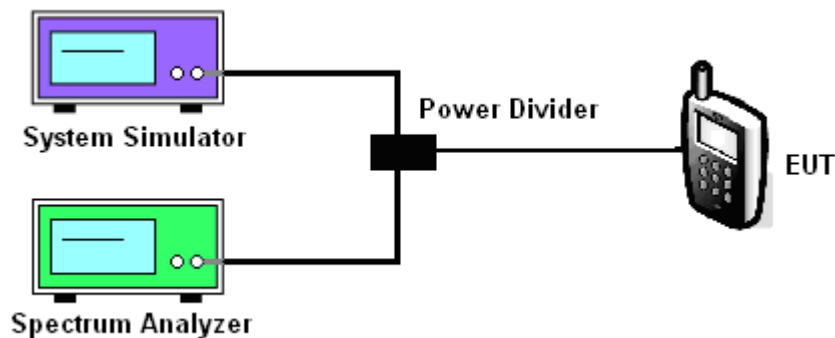

MODES TESTED

- LTE Band 2/4

Test data reference attachment.

----END OF REPORT----