

成品尺寸:420x128MM 105克铜版纸黑白正反面印刷

折叠成品尺寸: 105X128MM

Smart Outdoor Camera Users Manual

Model: IPC302

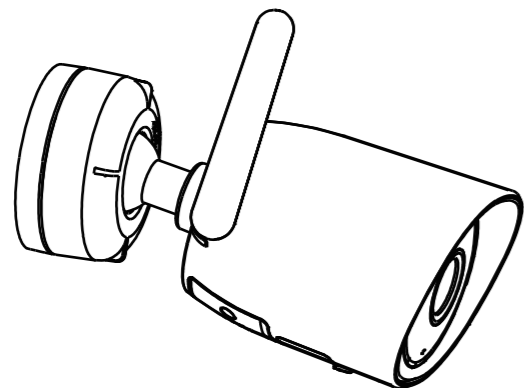

1 What's included

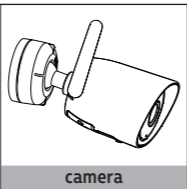
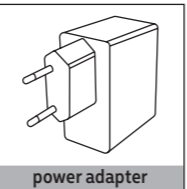
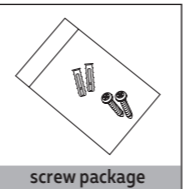
2 Parts of the Camera

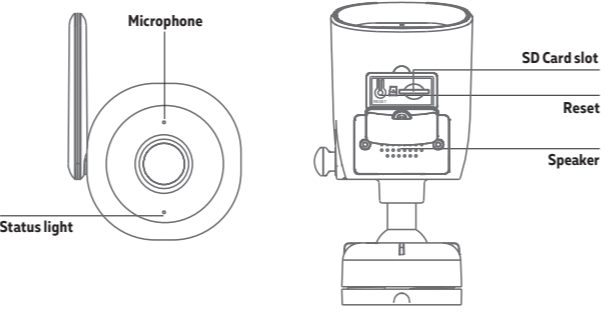

3 Initial Setup

DESCRIPTION:

Power DC 5V +/- 5%

Status lights:
Blue light solid on: system setup
Blue light blinking fast: waiting for the pairing
Blue light blinking slowly: waiting for the WiFi connection



Microphone Capture sound for your video
SD Card slot Support local micro SD Card storage (Max. 128GB)
Reset Press and hold the reset button for 5 seconds to reset the camera (if you have modified the settings, they will return to factory defaults)
 Before you start write down your network name & password.

Note: this item only works on a 2.4GHz Wi-Fi network, not on a 5GHz network. Please consult your router manual for settings. Please follow the instructions and make sure the passwords are correctly inputted.

One device can only be paired with one App account at a time, if the device has already been paired with another account, then it can't be paired to another account.



The device can be removed from the app account by being deleted from the app. The device will be reset automatically once the blue light changes to a solid on.

Preparations before use
 Mobile device system requirements:
 Android OS 4.4 or higher
 iOS 9.0 or higher

Install the App

Use your mobile phone or tablet to search for "TuyaSmart" in Google Play (for Android OS) or in the Apple app store (for iOS) to find the app, and install it according to the instructions.

Register an account

If this is the first time using the app, an account need to be registered as below:

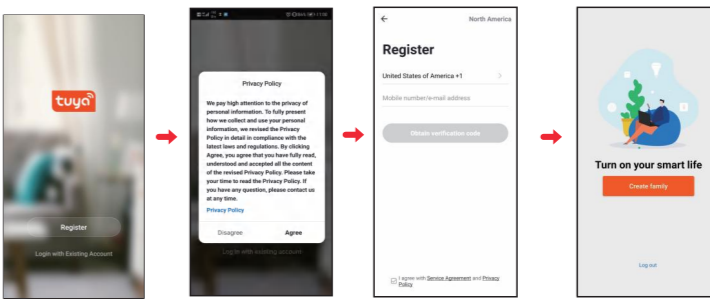

4 Connecting Your IP Camera with the App

Note: Your IPC Camera is supported only on a 2.4GHz Wi-Fi network. For setup, make sure your mobile device is connected to a 2.4GHz Wi-Fi network

- After installing the app 'Tuya Smart', open the app and follow the prompts to setup the app. Then tap '+' or 'Add Device' from the home page. Tap 'Security & Sensor', then choose 'Smart Camera'.
- Power the device on and hear the sound of 'camera start'. Make sure your smart device is connected to a 2.4G Wi-Fi network, then tap 'Confirm'.

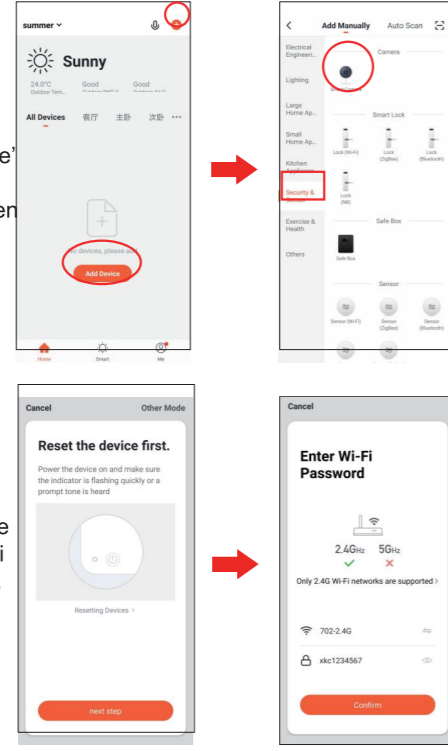

- The app will guide you to scan mobile device with the camera. When you tap 'Continue' the mobile phone displays a QR code. Hold the camera 15 to 20 cm in front of the mobile device for the camera to scan the QR code.
- In connecting, make sure your router, mobile and device are as close as possible. Once the camera get the information from mobile device, the camera will have a sound 'camera configured' which means the camera is connected successfully. Your camera's Live Camera view with streaming video will be opened.

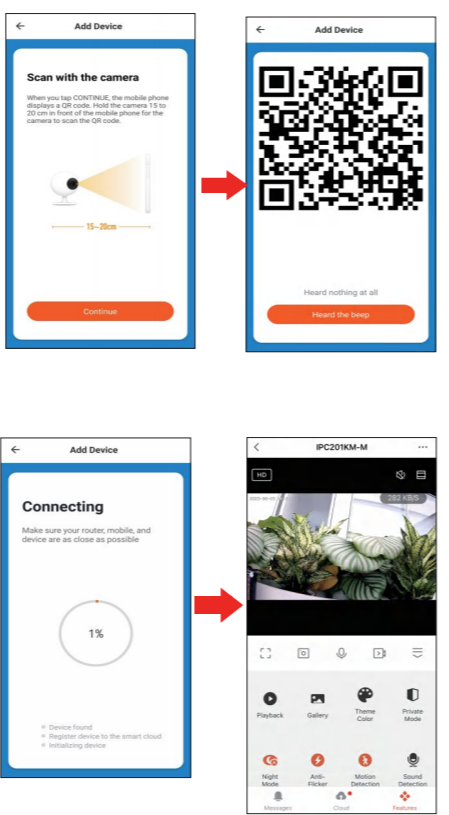

6 FAQ

PROBLEM	CORRECTIVE ACTION
Camera will not connect to my Wi-Fi network	<ol style="list-style-type: none"> Make sure the Wi-Fi signal is flashing. If the Wi-Fi signal is not flashing, you will need to press and hold Reset Button located at the back of the camera (see the Description section). Make sure the Wi-Fi network is a 2.4GHz network, device will not connect to a 5GHz network. Test your Wi-Fi network work with other devices such as your phone or computer to make sure it is operation properly. The Wi-Fi connection may be out of range during pairing. Use your phone to check range, it is recommended to have at least 2 signal bars showing for proper connection. Your Wi-Fi network password is case sensitive, make sure you are entering it correctly.
The camera is off-line	<ol style="list-style-type: none"> There could be a temporary issue with your internet connection (e.g., service disruption). Please try again in a few minutes. Make sure your Wi-Fi router is turned On. The camera may not have power to it, make sure the wall switch and breaker is in the On position. Make sure the camera is getting a good signal from your Wi-Fi router. Use your phone to check range, it is recommended to have at least 2 signal bars showing for proper connection. The camera may have been disconnected from your Wi-Fi network, press and hold Reset Button (see the Description section) until you hear an audible tone.
How to reset the camera to reenter pairing mode?	<ol style="list-style-type: none"> Press and hold reset button located at the back of the camera (see Description section) until you hear an audible tone.

FCC WARNING

This device complies with part 15 of the FCC Rules. Operation is subject to the following two conditions:
 (1) this device may not cause harmful interference, and (2) this device must accept any interference received, including interference that may cause undesired operation.

Any changes or modifications not expressly approved by the party responsible for compliance could void the user's authority to operate the equipment.

NOTE: This equipment has been tested and found to comply with the limits for a Class B digital device, pursuant to Part 15 of the FCC Rules. These limits are designed to provide reasonable protection against harmful interference in a residential installation.

This equipment generates, uses and can radiate radio frequency energy and, if not installed and used in accordance with the instructions, may cause harmful interference to radio communications. However, there is no guarantee that interference will not occur in a particular installation. If this equipment does cause harmful interference to radio or television reception, which can be determined by turning the equipment off and on, the user is encouraged to try to correct the interference by one or more of the following measures:

- Reorient or relocate the receiving antenna.
- Increase the separation between the equipment and receiver.
- Connect the equipment into an outlet on a circuit different from that to which the receiver is connected.
- Consult the dealer or an experienced radio/TV technician for help.

To maintain compliance with FCC's RF Exposure guidelines, This equipment should be installed and operated with minimum 20cm distance between the radiator and your body. Use only the supplied antenna.