

8110N-UR IOT MODULE

Data Sheet

V1.0

May.2017

8110N-UR Datasheet

Revision	Date	Description
V1.0	2017/05/05	Initial release

Copyright

© 2016-2017 YONGSHENHUI MATERIAL TECHNOLOGY CO., LTD.

This document is copyrighted with all rights reserved. No part of this publication may be reproduced, transmitted, transcribed, stored in a retrieval system, or translated into any language in any form by any means without the written permission of YONGSHENHUI MATERIAL TECHNOLOGY CO., LTD.

Notice

YONGSHENHUI MATERIAL TECHNOLOGY CO., LTD. reserves the right to change specifications without prior notice.

While the information in this manual has been compiled with great care, it may not be deemed an assurance of product characteristics. YONGSHENHUI MATERIAL TECHNOLOGY CO., LTD. shall be liable only to the degree specified in the terms of sale and delivery.

The reproduction and distribution of the documentation and software supplied with this product and the use of its contents is subject to written authorization from YONGSHENHUI MATERIAL TECHNOLOGY CO., LTD..

1. Introduction	4
2. Hardware Specification	6
2.1 8110N-UR module pinout	6
2.2 8110N-UR Interface summary	9
2.3 Bootstrap signals.....	9
2.4 Electrical characteristics.....	10
2.4.1 Absolute Maximum Ratings	10
2.4.2 Recommended Operating Conditions.....	10
2.4.3 General DC electrical characteristics	11
2.4.4 8110N-UR radio Rx characteristics.....	11
2.4.5 8110N-UR radio Tx characteristics	12
2.5 Timing specifications	13
2.5.1 SPI master interface timing.....	13
2.5.2 SPI slave interface timing	14
3. Mechanical Interface Specification	15
3.1 8110N-UR module dimensions	15
4. Manufacture information.....	16
4.1 Optical Inspection	16
4.2 Rework	16
4.3 Handling.....	16
4.4 Soldering Recommendations.....	16
5. Ordering Information.....	17

1. Introduction

8110N-UR Wi-Fi module provides a highly-integrated and flexible platform for developing and evaluating products and applications based on the QCA4010 SoC.

8110N-UR module includes the following components:

- QCA4010 chip
- An integrated Balun to save cost and size, minimize tuning and tolerance
- A printed antenna
- Apple MFI (optional)
- 2MB SPI Flash memory and etc.

The QCA4010 is a single band 1x1 802.11 b/g/n device optimized for low-power embedded applications with single-stream capability for both Tx and Rx. It has an integrated network processor with a large set of TCP/IP with IPv4/IPv6-based services. These services can be accessed via a serial SPI link or by a UART link connected to an external host CPU.

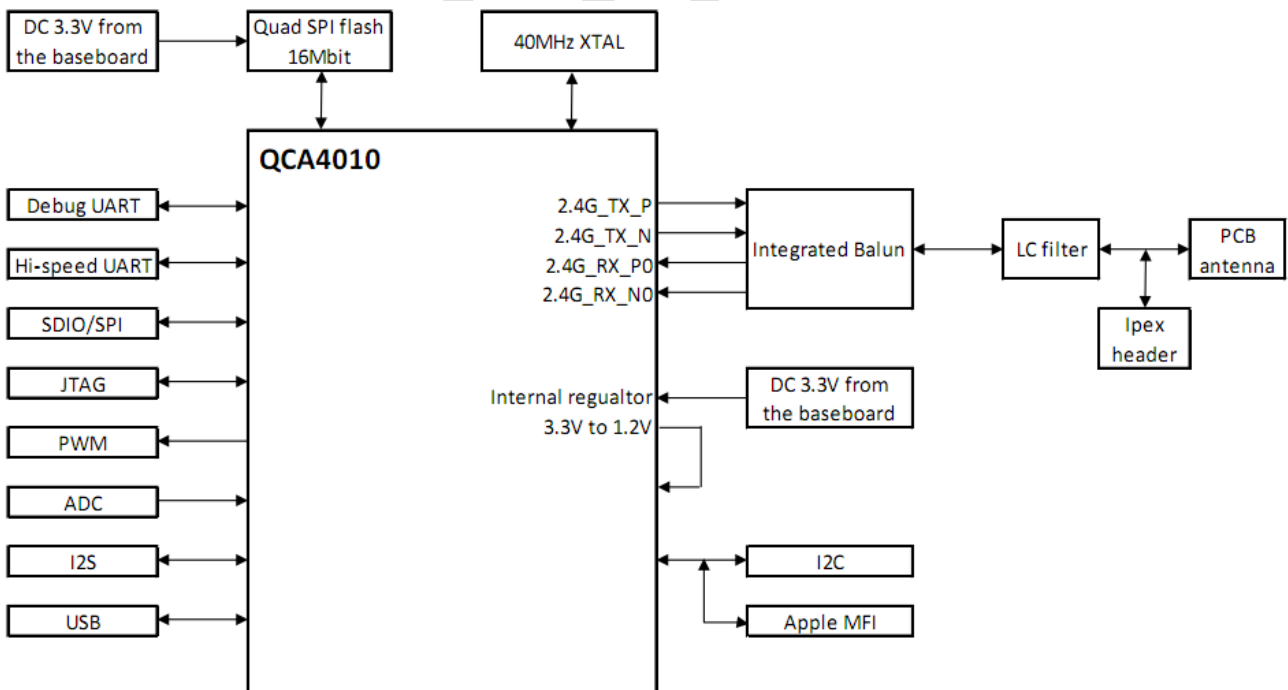

Figure 1-1 8110N-UR block diagram

8110N-UR Datasheet

8110N-UR Wi-Fi link features

- IEEE 802.11 b/g/n, single stream 1x1
- Single-band 2.4 GHz
- Integrated PA and LNA; support for external PA and external LNA
- Green Tx power saving mode
- Low power listen mode
- Four-layer PCB design
- Pre-certified FCC
- Data rates up to 150 Mbps
- Full security support: WPS,WEP, TKIP,WPA (personal),WPA2 (personal)

8110N-UR manufacturing interface

- USB 2.0 interface with integrated controller and PHY for manufacturing test and configuration

8110N-UR host interfaces

- UART host interface to a remote microcontroller with an AT style command set.

2. Hardware Specification

2.1 8110N-UR module pinout

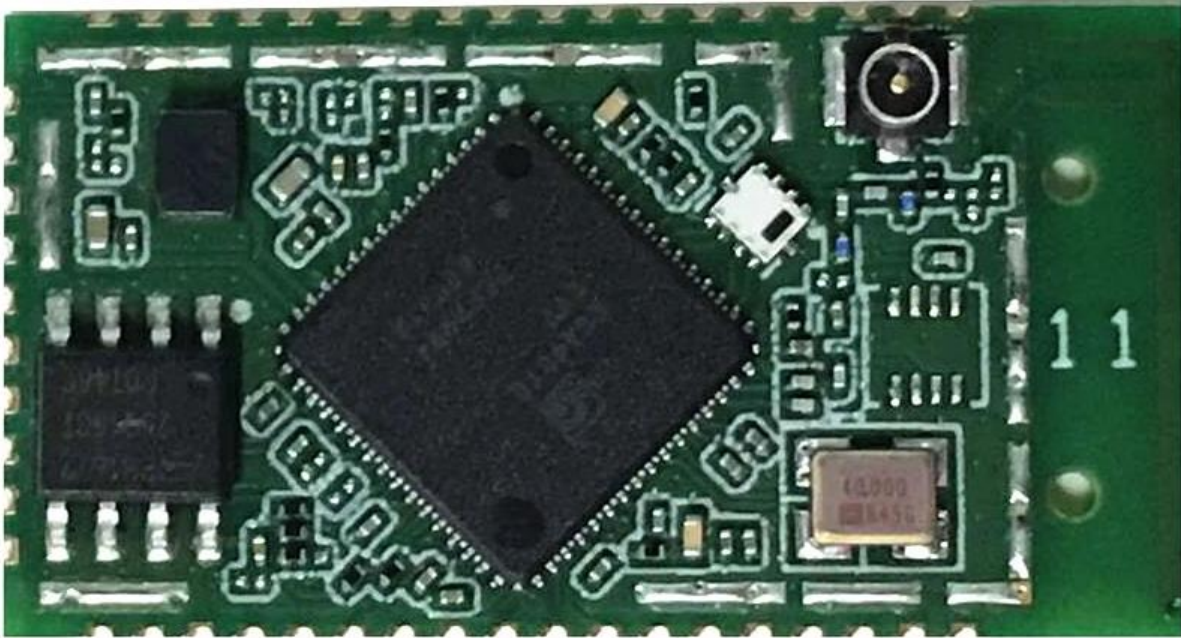

Figure 2-1 8110N-UR top view

8110N-UR Datasheet

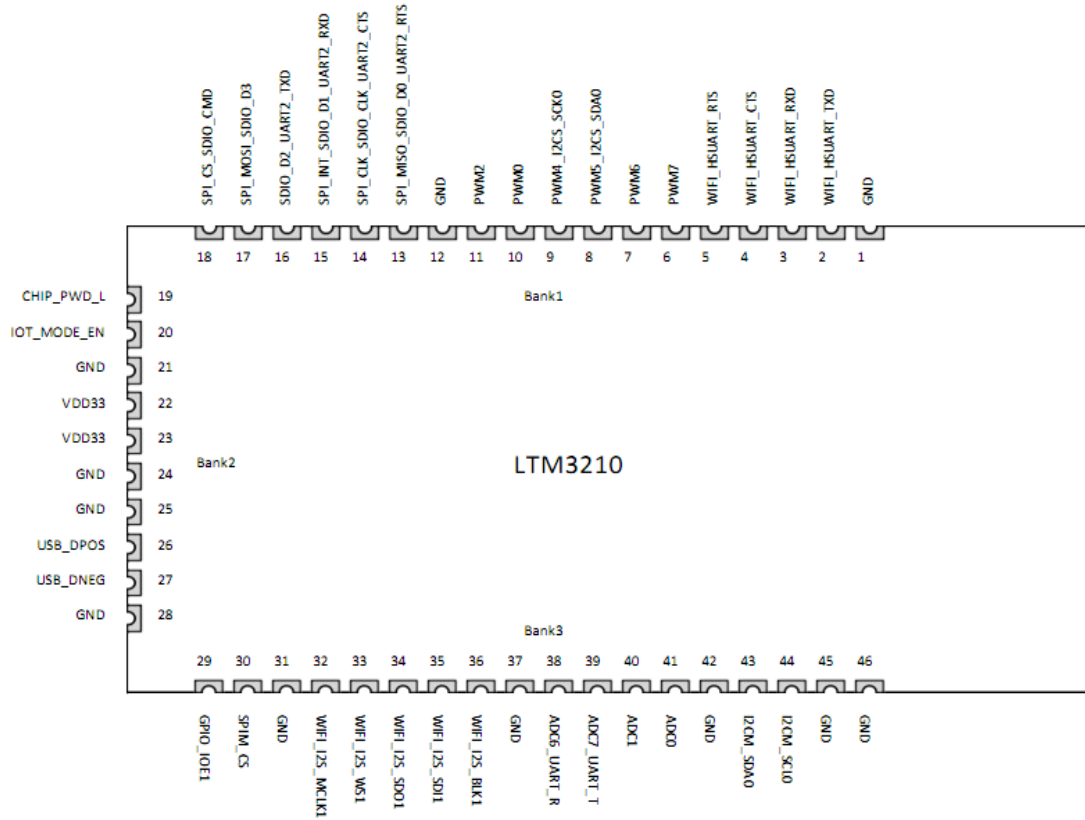

Figure 2-2 8110N-UR pinout definition

8110N-UR Datasheet

Table 2-1 8110N-UR module pinout definition and QCA4010 GPIO assignment

Pin	Signal/Interface	ALT1	ALT2	ALT3	GPIO No.
1	GND	Ground			
2	WIFI_UART1_RXD	High speed UART RXD			GPIO[24]
3	WIFI_UART1_TXD	High speed UART TXD			GPIO[23]
4	WIFI_UART1_RTS	High speed UART RTS			GPIO[22]
5	WIFI_UART1_CTS	High speed UART CTS			GPIO[21]
6	PWM7	PWM7			GPIO[13]
7	PWM6	PWM6			GPIO[12]
8	PWM5_I2CS_SDA0	PWM5	I2C Slave SDA0		GPIO[11]
9	PWM4_I2CS_SCK0	PWM4	I2C Slave SCK0		GPIO[10]
10	PWM0	PWM0			GPIO[6]
11	PWM2	PWM2			GPIO[8]
12	GND	Ground			
13	SPI_MISO_SDIO_D0_UART2_RTS	SPI MISO (master or slave)	SDIO Data0	UART RTS	GPIO[4]
14	SPI_CLK_SDIO_CLK_UART2_CTS	SPI CLK (master or slave)	SDIO CLK	UART CTS	GPIO[5]
15	SPI_INT_SDIO_D1_UART2_RXD	SPI Interrupt (slave)	SDIO Data1	UART RXD	GPIO[3]
16	SDIO_D2_UART2_TXD		SDIO Data2	UART TXD	GPIO[2]
17	SPI_MOSI_SDIO_D3	SPI MOSI (master or slave)	SDIO Data3		GPIO[1]
18	SPI_CS_SDIO_CMD	SPI CS (master or slave)	SDIO Command		GPIO[0]
19	CHIP_PWD_L	Module reset, active low			
20	IOT_MODE_EN	Wakeup manager enable			
21	GND	Ground			
22	VDD33	3.3V power supply			
23	VDD33	3.3V power supply			
24	GND	Ground			
25	GND	Ground			
26	USB_DPOS	USB Data+			
27	USB_DNEG	USB Data-			
28	GND	Ground			
29	GPIO_IOE1	external wakeup			
30	SPIM_CS	Flash memory /CS pin			GPIO[35]
31	GND	Ground			
32	WIFI_I2S_MCLK1	I2S MCLK1			GPIO[33]
33	WIFI_I2S_WS1	I2S WS1			GPIO[32]
34	WIFI_I2S_SDO1	I2S SDO1			GPIO[31]
35	WIFI_I2S_SDI1	I2S SDI1			GPIO[30]
36	WIFI_I2S_BLK1	I2S BLK1			GPIO[27]
37	GND	Ground			
38	ADC6_UART0_TX	ADC6	Debug UART TXD		GPIO[29]
39	ADC7_UART0_RX	ADC7	Debug UART		GPIO[28]

8110N-UR Datasheet

			RXD		
40	ADC1	ADC1			
41	ADC0	ADC0			
42	GND	Ground			
43	I2CM_SDA0	I2C Master SDA0			GPIO[25]
44	I2CM_SDL0	I2C Master SCL0			GPIO[26]
45	GND	Ground			
46	GND	Ground			

2.2 8110N-UR Interface summary

- Host interface: SPI master x 1, SDIO2.0 x 1, debug UART x 1
- High speed UART x 2
 - Up to 3Mbps data rate
- I2C master x 1, I2C slave x 1
 - Standard-mode and fast-mode
- I2S x 1
- PWM x 6
 - 18-bit resolution with 8-bit clock prescaler
- ADC x 4
 - 12-bit resolution, 400 Ksps for multiple channels and 1 Msp for single channel.
- All signal pins can be multiplexed as GPIO
- USB2.0 x 1, for ART tool

2.3 Bootstrap signals

Table 2-3 Bootstrap signals

Pin NO.	Bootstrap name	Description
11	Test mode enable	Should be low while reset released, for normal function
18 13	Host mode[1] Host mode[0]	Bootstrap for host interface selection. Default mode is 00.
		00 USB/manufacturing test and configuration/hostless
		01 Hostless (serial AT command) mode
		10 SPI host mode
		11 SDIO host mode
20	IOT mode enable	Keep high always, for normal function

2.4 Electrical characteristics

2.4.1 Absolute Maximum Ratings

Table 2-4-1 summarizes the absolute maximum ratings and Table 2-4-2 lists the recommended operating conditions for the 8110N-UR. Absolute maximum ratings are those values beyond which damage to the device can occur.

Functional operation under these conditions, or at any other condition beyond those indicated in the operational sections of this document, is not recommended.

NOTE: Maximum rating for signals follows the supply domain of the signals.

Table 2-4-1 absolute maximum ratings

symbol	Description	Max rating	unit
VDD33	VDD supply for whole chip	- 0.3 to 4.0	V
VIH MIN	Minimum Digital I/O Input Voltage for 1.8 V or 3.3 V I/O Supply	- 0.3	V
3.3 V I/O VIH MAX	Maximum Digital I/O Input Voltage for 3.3 V I/O Supply	Vdd +0.3	V
RFin	Maximum RF input (reference to 50-Ω input)	+10	dbm
Tstore	Storage Temperature	- 45 to 135	° C
Tj	Junction Temperature	125	° C
ESD	Electrostatic Discharge Tolerance	HBM - 2000 CDM - 500	V

2.4.2 Recommended Operating Conditions

These conditions apply to all DC characteristics unless otherwise specified:

Tamb = 25 °C, Vdd33= 3.3 V

Table 2-4-2 Recommended Operating Conditions

Symbol	Parameter	Min	Typ	Max	unit
VDD33	VDD supply for whole chip	3.14	3.3	3.46	V
Tcase	Case temperature	0	-	70	° C
PsiJT	Thermal Parameter2	-	3	-	° C/W

8110N-UR Datasheet

2.4.3 General DC electrical characteristics

These conditions apply to all DC characteristics unless otherwise specified:

$T_{amb} = 25\text{ }^{\circ}\text{C}$, $V_{in} = 3.3\text{ V}$

Table 2-4-3 DC Electrical characteristics for digital I/Os

Symbol	Parameter	Min	Typ	Max	Unit
VIH	High level I voltage	1.8	-	3.6	V
VIL	Low level I voltage	-0.3	-	0.3	V
VOH	High level O voltage	2.2	-	3.3	V
VOL	Low level O voltage	0	-	0.4	V

2.4.4 8110N-UR radio Rx characteristics

Table 2-4-4 8110N-UR Main Rx characteristics for 2.4Ghz operation

Symbol	Parameter	Conditions	Min	Typ	Max	Unit
Frx	RX input frequency range	-	2.412	-	2.472	GHz
Srf	Sensitivity					
	CCK	1Mbps	-	-93	-	dBm
		11Mbps	-	-87	-	
	OFDM	6Mbps	-	-89	-	
		54Mbps	-	-73	-	
	HT20	MCS0	-	-89	-	
MCS7		-	-70	-		
Racj	Adjacent channel rejection					
	CCK	2Mbps	-	47	-	dB
		6Mbps	-	36	-	
	OFDM	54Mbps	-	21	-	
		MCS0	-	34	-	
	HT20	MCS7	-	18	-	

In LPL mode, sensitivity will be degraded by 1~2dB.

2.4.5 8110N-UR radio Tx characteristics

Table 2-4-5 8110N-UR Tx characteristics for 2.4GHZ operation

Symbol	Parameter	Conditions	Min	Typ	Max	Unit
Ftx	Tx output frequency range	-	2.412	-	2.472	GHz
Pout	Output power					
	802.11b mask compliant	1 Mbps	-	19	-	dBm
	802.11g mask compliant	6 Mbps	-	19	-	
	802.11g EVM compliant	54 Mbps	-	16	-	
	802.11n HT20 mask compliant	MCS0	-	19	-	
	802.11n HT20 EVM compliant	MCS7	-	15	-	
Refer to IEEE802.11specification for TX spectrum limits: <ul style="list-style-type: none"> ▫ 802.11b mask(18.4.7.3) ▫ 802.11g mask(19.5.4) ▫ 802.11g EVM(17.3.9.6.3) ▫ 802.11n HT20 mask(20.3.21.1) ▫ 802.11n HT20 EVM(20.3.21.7.3) 						

2.5 Timing specifications

2.5.1 SPI master interface timing

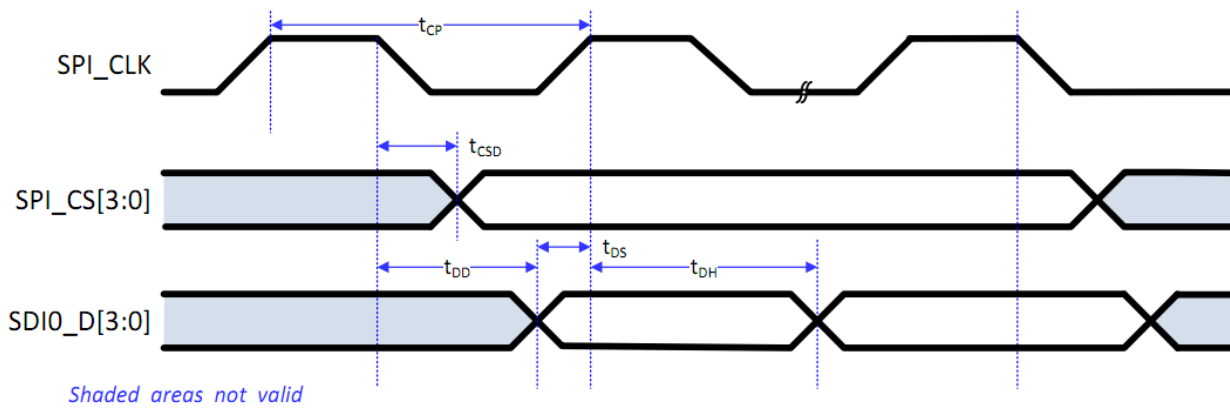

Figure 2-3 8110N-UR SPI master timing

Table 2-5-1 SPI master timing

Parameter	Description	Min	Max	Unit
t_{CP}	Clock period	30.7	1000	ns
t_{CSD}	Chip select valid delay	-5.5	5	ns
t_{DD}	Data valid delay	-5.5	5	ns
t_{DS}	Data setup	3	-	ns
t_{DH}	Data hold	0	-	ns

2.5.2 SPI slave interface timing

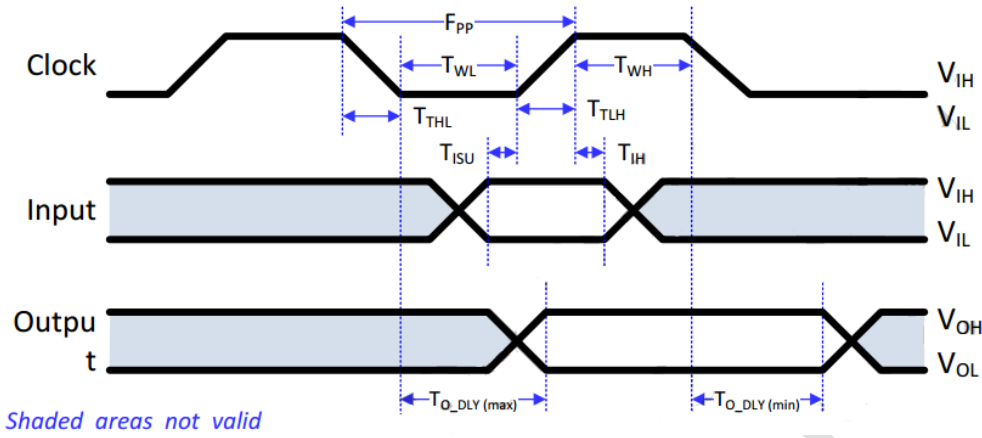

Table 2-5-2 SPI slave timing

Parameter	Description	Min	Max	Unit
f_{pp}	Clock frequency	0	48	MHz
t_{WL}	Clock low time	8.3	-	ns
t_{WH}	Clock high time	8.33	-	ns
t_{TLH}	Clock rise time	-	2	ns
t_{THL}	Clock fall time	-	2	ns
t_{ISU}	Input setup time	5	-	ns
t_{IH}	Input hold time	5	-	ns
t_{O_DLY}	Output delay	0	5	ns

3. Mechanical Interface Specification

3.1 8110N-UR module dimensions

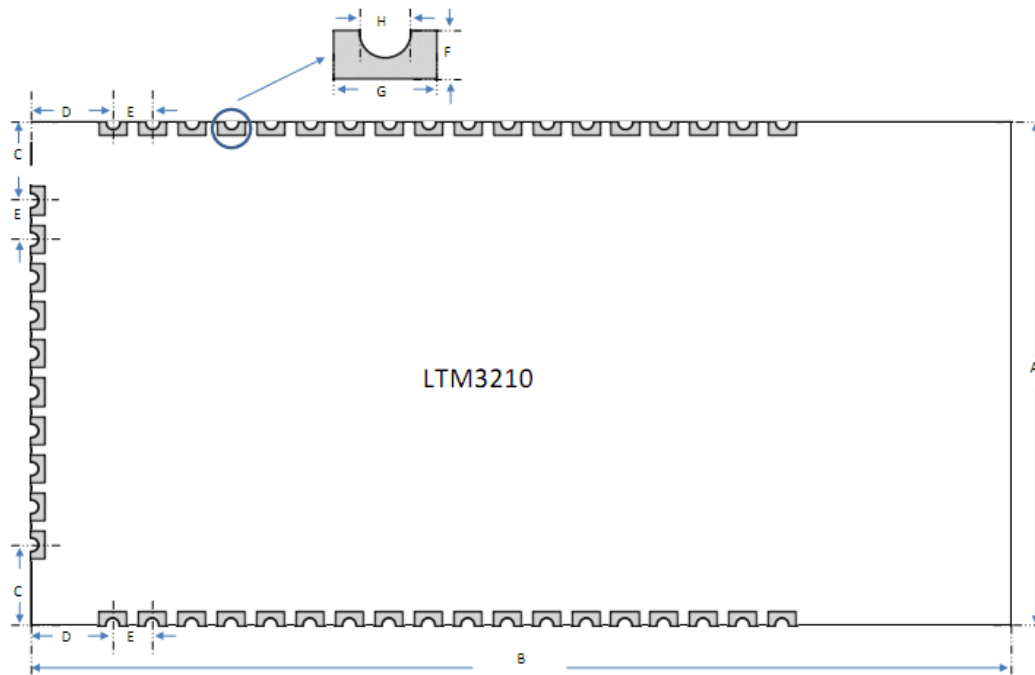

Figure 3-1 8110N-UR module dimensions

Table 3-1 8110N-UR module dimensions

Label	Dimension(mm)
A	16
B	30
C	2.285
D	2.54
E	1.27
F	0.4
G	0.7
H(diameter)	0.5
Module height(including the RF shield)	2.6
Total height (with a coax cable plugged into the U.FL connector)	3.6

4. Manufacture information

4.1 Optical Inspection

After SMT, 8110N-UR PCBA will be automatically sent to do AOI (Automatic Optic Inspection).

Yongshenhui uses TR7500 to check every CHIP.

TR7500 features:

- 3CCD camera with 5 detectors
- All pictures have the sense of 3D
- Resolution: 10 μ m

TR7500 can detect blemishes during SMT to guarantee quality at the first step before IOE and fully functional test.

4.2 Rework

The module can be unsoldered from the host board if the Moisture Sensitivity Level (MSL) requirements are met as described in this data sheet. Never attempt a rework on the module itself, e.g. replacing individual components. Such actions will terminate warranty coverage.

4.3 Handling

The 8110N-UR contains a highly sensitive electronic circuitry. Handling without proper ESD protection may destroy or damage the chip permanently.

4.4 Soldering Recommendations

The 8110N-UR can be SMT on the board following the temperature curve graph :

8110N-UR Datasheet

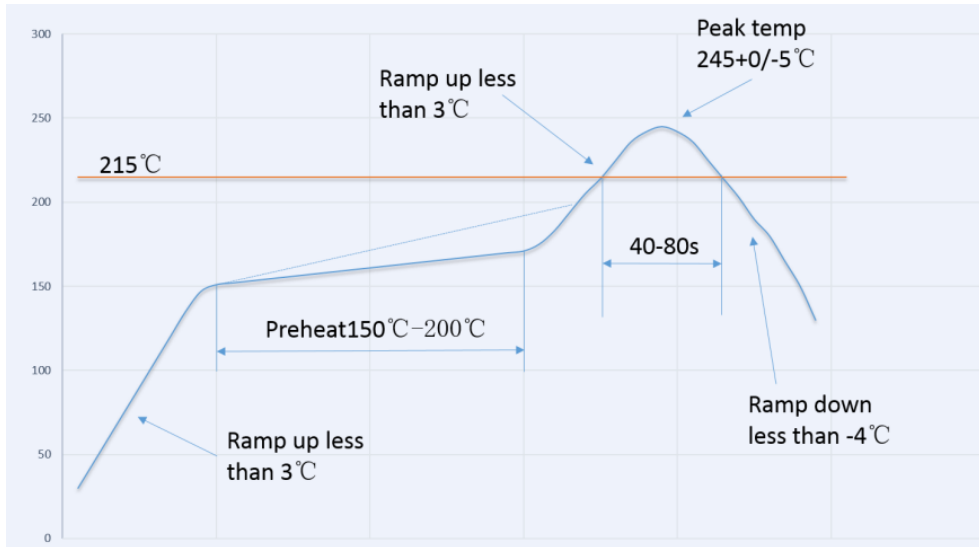

Figure 4-1 8110N-UR Profile Proposal

5. Ordering Information

<TBD>

6. FCC Statement

This device complies with Part 15 of the FCC Rules. Operation is subject to the following two conditions: (1) this device may not cause harmful interference, and (2) this device must accept any interference received, including interference that may cause undesired operation.

Warning: changes or modifications not expressly approved by the party responsible for compliance could void the user's authority to operate the equipment.

Please notice that if the FCC identification number is not visible when the module is installed inside another device, then the outside of the device into which the module is installed must also display a label referring to the enclosed module. This exterior label can use wording such as the following: "Contains FCC ID:2AQ78-8110NUR" any similar wording that expresses the same meaning may be used.

RF Exposure Information:

This equipment complies with FCC radiation exposure limits set forth for an uncontrolled environment. This equipment should be installed and operated with a minimum distance of 20cm between the radiator & your body. This transmitter must not be co-located or operating in conjunction with any other antenna or transmitter.

Installation Information:

8110N-UR Datasheet

The module is limited to OEM installation ONLY.

The OEM integrator is responsible for ensuring that the end-user has no manual instruction to remove or install module.

The module is limited to installation in mobile application;

A separate approval is required for all other operating configurations, including portable configurations with respect to Part 2.1093 and difference antenna configurations.

The OEM integrator is responsible for ensuring that the host product which is installed and operating with the module is in compliant with Part 15B unintentional Radiator requirements, please note that for a Class B digital device or peripheral, the instructions furnished the user manual of the end-user product shall include the following or similar statement, placed in a prominent location in the text of the manual:

Note: This equipment has been tested and found to comply with the limits for a Class B digital device, pursuant to

part 15 of the FCC Rules. These limits are designed to provide reasonable protection against harmful interference in a residential installation. This equipment generates, uses and can radiate radio frequency energy and, if not installed and used in accordance with the instructions, may cause harmful interference to radio communications. However, there is no guarantee that interference will not occur in a particular installation. If this equipment does cause harmful interference to radio or television reception, which can be determined by turning the equipment off and on, the user is encouraged to try to correct the interference by one or more of the following measures:

- Reorient or relocate the receiving antenna.
- Increase the separation between the equipment and receiver.
- Connect the equipment into an outlet on a circuit different from that to which the receiver is connected.
- Consult the dealer or an experienced radio/TV technician for help.