

# FCC Test Report

## (Spot Check: Part 96)

**Report No.:** RF200109E02E-4

**FCC ID:** 2AQ68T99W175M

**Original FCC ID:** 2AQ68T99W175

**Test Model:** T99W175M

**Received Date:** May 29, 2020

**Test Date:** Jul. 03 ~ Aug. 02, 2020

**Issued Date:** Aug. 10, 2020

**Applicant:** Hon Lin Technology Co., Ltd.

**Address:** 11F, No. 32, Jihu Rd., Neihu Dist., Taipei City 114, Taiwan R.O.C.

**Issued By:** Bureau Veritas Consumer Products Services (H.K.) Ltd., Taoyuan Branch  
Lin Kou Laboratories

**Lab Address:** No. 47-2, 14th Ling, Chia Pau Vil., Lin Kou Dist., New Taipei City, Taiwan

**Test Location:** No. 19, Hwa Ya 2nd Rd., Wen Hwa Vil., Kwei Shan Dist., Taoyuan City  
33383, Taiwan

**FCC Registration/  
Designation Number:** 788550 / TW0003



This report is for your exclusive use. Any copying or replication of this report to or for any other person or entity, or use of our name or trademark, is permitted only with our prior written permission. This report sets forth our findings solely with respect to the test samples identified herein. The results set forth in this report are not indicative or representative of the quality or characteristics of the lot from which a test sample was taken or any similar or identical product specifically and expressly noted. Our report includes all of the tests requested by you and the results thereof based upon the information that you provided to us. You have 60 days from date of issuance of this report to notify us of any material error or omission caused by our negligence, provided, however, that such notice shall be in writing and shall specifically address the issue you wish to raise. A failure to raise such issue within the prescribed time shall constitute your unqualified acceptance of the completeness of this report, the tests conducted and the correctness of the report contents. Unless specific mention, the uncertainty of measurement has been explicitly taken into account to declare the compliance or non-compliance to the specification.

## Table of Contents

<b>Release Control Record</b> .....	<b>3</b>
<b>1 Certificate of Conformity</b> .....	<b>4</b>
<b>2 Summary of Test Results</b> .....	<b>5</b>
2.1 Measurement Uncertainty .....	5
2.2 Modification Record .....	5
<b>3 General Information</b> .....	<b>6</b>
3.1 General Description of EUT .....	6
3.2 Test Mode Applicability and Tested Channel Detail .....	10
3.3 Description of Support Units .....	12
3.3.1 Configuration of System under Test .....	12
3.4 General Description of Applied Standards and References.....	13
<b>4 Test Types and Results</b> .....	<b>14</b>
4.1 Maximum Output Power Measurement .....	14
4.1.1 Limits of Maximum Output Power Measurement .....	14
4.1.2 Test Setup.....	14
4.1.3 Test Instruments .....	15
4.1.4 Test Procedures.....	16
4.1.5 Deviation from Test Standard .....	16
4.1.6 EUT Operating Conditions.....	16
4.1.7 Test Results .....	17
4.2 Radiated Emission Measurement .....	33
4.2.1 Limits of Radiated Emission Measurement .....	33
4.2.2 Test Instruments .....	33
4.2.3 Test Procedures.....	33
4.2.4 Deviation from Test Standard .....	33
4.2.5 Test Set Up .....	34
4.2.6 Test Results .....	35
<b>5 Pictures of Test Arrangements</b> .....	<b>38</b>
<b>Appendix – Information of the Testing Laboratories</b> .....	<b>39</b>

### Release Control Record

Issue No.	Description	Date Issued
RF200109E02E-4	Original release	Aug. 10, 2020

## 1 Certificate of Conformity

**Product:** 5G WWAN Module

**Brand:** Foxconn

**Test Model:** T99W175M

**Sample Status:** Engineering Sample

**Applicant:** Hon Lin Technology Co., Ltd.

**Test Date:** Jul. 03 ~ Aug. 02, 2020

**Standards:** FCC 47 CFR Part 96

The above equipment has been tested by **Bureau Veritas Consumer Products Services (H.K.) Ltd., Taoyuan Branch**, and found compliance with the requirement of the above standards. The test record, data evaluation & Equipment Under Test (EUT) configurations represented herein are true and accurate accounts of the measurements of the sample's RF characteristics under the conditions specified in this report.

**Prepared by :** Pettie Chen , **Date:** Aug. 10, 2020  
Pettie Chen / Senior Specialist

**Approved by :** Bruce Chen , **Date:** Aug. 10, 2020  
Bruce Chen / Senior Project Engineer

## 2 Summary of Test Results

47 CFR FCC Part 96			
FCC Clause	Test Item	Result	Remarks
2.1046 96.41(b)	Maximum Peak Output Power	Pass	Meet the requirement of limit.
2.1053 96.41(e)	Radiated Spurious Emissions	Pass	Meet the requirement of limit. Minimum passing margin is -2.8dB at 77.80MHz.

Note: Determining compliance based on the results of the compliance measurement, not taking into account measurement instrumentation uncertainty.

### 2.1 Measurement Uncertainty

Where relevant, the following measurement uncertainty levels have been estimated for tests performed on the EUT as specified in CISPR 16-4-2:

Measurement	Frequency	Expanded Uncertainty (k=2) ( $\pm$ )
Radiated Emissions up to 1 GHz	9 kHz ~ 30MHz	3.04 dB
	30 MHz ~ 200 MHz	3.59 dB
	200 MHz ~ 1000 MHz	3.60 dB
Radiated Emissions above 1 GHz	1 GHz ~ 18 GHz	2.29 dB
	18 GHz ~ 40 GHz	2.29 dB

### 2.2 Modification Record

There were no modifications required for compliance.

### 3 General Information

#### 3.1 General Description of EUT

Product	5G WWAN Module					
Brand	Foxconn					
Test Model	T99W175M					
Status of EUT	Engineering Sample					
Power Supply Rating	5 Vdc (Host equipment) 3.135Vdc~3.63Vdc (Module)					
Modulation Type	QPSK, 16QAM, 64QAM, 256QAM					
Operating Frequency	LTE Band 48	Channel Bandwidth 5MHz	TX: 3552.5 ~ 3697.5 MHz			
			RX: 3552.5 ~ 3697.5 MHz			
		Channel Bandwidth 10MHz	TX: 3555 ~ 3695 MHz			
			RX: 3555 ~ 3695 MHz			
		Channel Bandwidth 15MHz	TX: 3557.5 ~ 3692.5 MHz			
			RX: 3557.5 ~ 3692.5 MHz			
		Channel Bandwidth 20MHz	TX: 3560 ~ 3690 MHz			
			RX: 3560 ~ 3690 MHz			
		LTE Band 42	Channel Bandwidth 5MHz	TX: 3552.5 ~ 3597.5 MHz		
			RX: 3552.5 ~ 3597.5 MHz			
			Channel Bandwidth 10MHz	TX: 3555 ~ 3595 MHz		
			RX: 3555 ~ 3595 MHz			
		Channel Bandwidth 15MHz	TX: 3557.5 ~ 3592.5 MHz			
		RX: 3557.5 ~ 3592.5 MHz				
		Channel Bandwidth 20MHz	TX: 3560 ~ 3590 MHz			
		RX: 3560 ~ 3590 MHz				
Max. EIRP Power	LTE Band 48		QPSK	16QAM	64QAM	256QAM
			<b>Per 10M</b>			
		Channel Bandwidth 5MHz	156.315mW (21.94dBm)	133.968mW (21.27dBm)	101.391mW (20.06dBm)	75.509mW (18.78dBm)
		Channel Bandwidth 10MHz	158.489mW (22.00dBm)	133.045mW (21.24dBm)	106.414mW (20.27dBm)	76.913mW (18.86dBm)
		Channel Bandwidth 15MHz	181.134mW (22.58dBm)	144.212mW (21.59dBm)	113.501mW (20.55dBm)	77.625mW (18.90dBm)
		Channel Bandwidth 20MHz	175.388mW (22.44dBm)	134.586mW (21.29dBm)	114.551mW (20.59dBm)	74.131mW (18.70dBm)
			<b>Full Power</b>			
		Channel Bandwidth 5MHz	156.315mW (21.94dBm)	133.968mW (21.27dBm)	101.391mW (20.06dBm)	75.509mW (18.78dBm)
		Channel Bandwidth 10MHz	158.489mW (22.00dBm)	133.045mW (21.24dBm)	106.414mW (20.27dBm)	76.913mW (18.86dBm)
		Channel Bandwidth 15MHz	180.717mW (22.57dBm)	155.239mW (21.91dBm)	121.899mW (20.86dBm)	79.616mW (19.01dBm)
		Channel Bandwidth 20MHz	184.077mW (22.65dBm)	160.325mW (22.05dBm)	118.577mW (20.74dBm)	78.886mW (18.97dBm)

Max. EIRP Power	LTE Band 42	Modulation				
		QPSK	16QAM	64QAM	256QAM	
		<b>Per 10M</b>				
	Channel Bandwidth 5MHz	145.211mW (21.62dBm)	122.180mW (20.87dBm)	91.833mW (19.63dBm)	65.313mW (18.15dBm)	
	Channel Bandwidth 10MHz	130.617mW (21.16dBm)	108.643mW (20.36dBm)	81.096mW (19.09dBm)	54.075mW (17.33dBm)	
	Channel Bandwidth 15MHz	162.555mW (22.11dBm)	130.617mW (21.16dBm)	103.753mW (20.16dBm)	68.077mW (18.33dBm)	
	Channel Bandwidth 20MHz	167.880mW (22.25dBm)	130.918mW (21.17dBm)	103.039mW (20.13dBm)	70.795mW (18.50dBm)	
		<b>Full Power</b>				
	Channel Bandwidth 5MHz	145.211mW (21.62dBm)	122.180mW (20.87dBm)	91.833mW (19.63dBm)	65.313mW (18.15dBm)	
	Channel Bandwidth 10MHz	130.617mW (21.16dBm)	108.643mW (20.36dBm)	81.096mW (19.09dBm)	54.075mW (17.33dBm)	
	Channel Bandwidth 15MHz	135.207mW (21.31dBm)	117.490mW (20.70dBm)	88.308mW (19.46dBm)	52.966mW (17.24dBm)	
	Channel Bandwidth 20MHz	158.489mW (22.00dBm)	137.088mW (21.37dBm)	96.828mW (19.86dBm)	59.156mW (17.72dBm)	
Emission Designator	LTE Band 48	Channel Bandwidth 5MHz	4M49G7D	4M49D7W	4M49D7W	4M48D7W
		Channel Bandwidth 10MHz	8M96G7D	8M97D7W	8M96D7W	8M96D7W
		Channel Bandwidth 15MHz	13M5G7D	13M4D7W	13M4D7W	13M4D7W
		Channel Bandwidth 20MHz	17M9G7D	17M9D7W	17M9D7W	17M9D7W
	LTE Band 42	Channel Bandwidth 5MHz	4M48G7D	4M49D7W	4M49D7W	4M48D7W
		Channel Bandwidth 10MHz	8M95G7D	8M97D7W	8M96D7W	8M96D7W
		Channel Bandwidth 15MHz	13M5G7D	13M4D7W	13M4D7W	13M4D7W
		Channel Bandwidth 20MHz	17M9G7D	17M9D7W	17M9D7W	17M9D7W
Antenna Type	Refer to Note as below					
Antenna Connector	Refer to Note as below					
Accessory Device	NA					
Cable Supplied	NA					

Note:

1. This report is a supplementary report to the original BV CPS report no.: RF200109E02B-4. The difference compared with original report is only adding mmWave hardware, mmWave function is disabled by software. Exhibit prepared for FCC Spot Check Verification report, the format, test items and amount of spot-check test data are decided by applicant's engineering judgment, for more details please refer to declaration letter exhibit. Radiated emission and output power verification worst test refer to original report.
2. There are four Difference HW of T99W175M.

Brand	Model	HW
Foxconn	T99W175M	1. 3G+LTE+Sub6+mmWave+eSIM
		2. 3G+LTE+Sub6+mmWave+w/o eSIM
		3. 3G+LTE+Sub6+mmWave+eSIM+GNSS connector
		4. 3G+LTE+Sub6+mmWave+w/o eSIM+GNSS connector

\*After pre-testing, "HW: 1. 3G+LTE+Sub6+mmWave+eSIM" is the worst for the final tests.

## 3. The following antennas were provided to the EUT.

Antenna No.	RF Chain No.	Brand	Model	Antenna Net Gain(dBi)	Frequency range (MHz)	Antenna Type	Connector Type
1		WHA YU	C107-511720-A	4.41	660~803	PCB	I-PEX
2		WHA YU	C107-511721-A	3.81 4.03	791~960 1447.9~1606	PCB	I-PEX
3		WHA YU	C107-511722-A	4.27 5.31	1710~2170 2500~2690	PCB	I-PEX
4		WHA YU	C107-511723-A	2.99 0.92	2300~2400 3500~3700	PCB	I-PEX
5		WHA YU	C107-511724-A	6.45	5150~5925	PCB	I-PEX
6		WHA YU	C107-511725-A	4.89	3400~3700	PCB	I-PEX
7		AVX	5000106-R1-X01	2.91	699~803	Monopole	I-PEX
8		AVX	5000107-R1-X01	2.59	791~960	Monopole	I-PEX
9		AVX	5000108-R1-X01	2.85	1427~1610	Monopole	I-PEX
10		AVX	5000109-R1-X01	2.23 2.94	1710~2200 5150~5925	Monopole	I-PEX
11		AVX	5000110-R1-X01	0.9	2300~2690	Monopole	I-PEX
12		AVX	5000111-R1-X01	0.87	3300~5000	Monopole	I-PEX
13	Tx1/ Rx1	Ethertronics	5003806	0.4 -1.61 0.39 2.95 1.98 0.38 0.83 2.31	698-821 824-960 1425-1515 1710-2200 2300-2690 3300-4200 4400-5000 5150-5925	PIFA	I-PEX
	Rx2	Ethertronics	5003807	-2.24 -4.52 2.87 2.99 2.93 2.91 2.23 -0.85 -3.04	716-821 824-960 1425-1515 1557-1610 1805-2200 2300-2690 3300-4200 4400-5000 5150-5925	PIFA	I-PEX
	Tx2/ Rx3	Ethertronics	5003806	2.21 2.25 -0.45 2.6	1710-2200 2300-2690 3300-4200 4400-5000	PIFA	I-PEX
	Rx4	Ethertronics	5003700	1.38 2.87 0.6 -2.09	1805-2200 2300-2690 3300-4200 4400-5000	PIFA	I-PEX



Antenna No.	RF Chain No.	Brand	Model	Antenna Net Gain(dBi)	Frequency range (MHz)	Antenna Type	Connector Type
14	Ant. 0 (TX/RX)	Master Wave	NA	2.4	880~960	PCB	I-PEX
				2.2	1020~2170		
				2.9	2545~2595		
				2.9	3565~3600		
				2.9	3900~4000		
	NA	GPS					
	Ant. 2 (TX/RX)	Master Wave	NA	NA	880~960	PCB	I-PEX
				2.2	1020~2170		
				2.8	2545~2595		
				2.9	3565~3600		
				2.8	3900~4000		
	NA	GPS					
	Ant. 1 (RX)	Master Wave	NA	NA	880~960	PCB	I-PEX
				5.3	1020~2170		
				5.1	2545~2595		
				4.3	3565~3600		
4.5				3900~4000			
NA	GPS						
Ant. 3 (RX)	Master Wave	NA	1.3	880~960	PCB	I-PEX	
			6.8	1020~2170			
			3.7	2545~2595			
			6.4	3565~3600			
			6.2	3900~4000			
3.7	GPS						

\*The above Antenna information is declared by manufacturer and for more detailed features description, please refer to the manufacturer's specifications, the laboratory shall not be held responsible.

\*The antenna for the final tests as following table.

	Band	Antenna
WCDMA	2	Antenna 3
	4	Antenna 3
	5	Antenna 2
LTE	2	Antenna 3
	4	Antenna 3
	5	Antenna 2
	7	Antenna 3
	12	Antenna 1
	13	Antenna 1
	14	Antenna 1
	17	Antenna 1
	25	Antenna 3
	26	Antenna 2
	30	Antenna 4
	66	Antenna 3
	71	Antenna 1
	38	Antenna 3
	41	Antenna 3
42	Antenna 4	
48	Antenna 4	

### 3.2 Test Mode Applicability and Tested Channel Detail

Pre-Scan has been conducted to determine the worst-case mode from all possible combinations between available modulations, data rates, XYZ axis and antenna ports

The worst case was found when positioned on Z-plane. Following channel(s) was (were) selected for the final test as listed below:

#### LTE Band 48

Test Item	Available Channel	Tested Channel	Channel Bandwidth	Modulation	Mode
Maximum Output Power	55265 to 56715	55265 (3552.5MHz), 55990 (3625.0MHz), 56715 (3697.5MHz)	5MHz	QPSK / 16QAM / 64QAM / 256QAM	1 RB / 0 RB Offset 1 RB / 12 RB Offset 1 RB / 24 RB Offset 12 RB / 0 RB Offset 12 RB / 6 RB Offset 12 RB / 13 RB Offset 25 RB / 0 RB Offset
	55290 to 56690	55290 (3555.0MHz), 55990 (3625.0MHz), 56690 (3695.0MHz)	10MHz	QPSK / 16QAM / 64QAM / 256QAM	1 RB / 0 RB Offset 1 RB / 24 RB Offset 1 RB / 49 RB Offset 25 RB / 0 RB Offset 25 RB / 12 RB Offset 25 RB / 25 RB Offset 50 RB / 0 RB Offset
	55315 to 56665	55315 (3557.5MHz), 55990 (3625.0MHz), 56665 (3692.5MHz)	15MHz	QPSK / 16QAM / 64QAM / 256QAM	1 RB / 0 RB Offset 1 RB / 37 RB Offset 1 RB / 74 RB Offset 36 RB / 0 RB Offset 36 RB / 19 RB Offset 36 RB / 39 RB Offset 75 RB / 0 RB Offset
	55340 to 56640	55340 (3560.0MHz), 55990 (3625.0MHz), 56640 (3690.0MHz)	20MHz	QPSK / 16QAM / 64QAM / 256QAM	1 RB / 0 RB Offset 1 RB / 50 RB Offset 1 RB / 99 RB Offset 50 RB / 0 RB Offset 50 RB / 25 RB Offset 50 RB / 50 RB Offset 100 RB / 0 RB Offset
Radiated Emission Below 1GHz	55340 to 56640	55990 (3625.0MHz)	20MHz	QPSK	1 RB / 0 RB Offset
Radiated Emission Above 1GHz	55340 to 56640	55990 (3625.0MHz)	20MHz	QPSK	1 RB / 0 RB Offset

## LTE Band 42

Test Item	Available Channel	Tested Channel	Channel Bandwidth	Modulation	Mode
Maximum Output Power	43115 to 43565	43115 (3552.5MHz), 43340 (3575.0MHz), 43565 (3597.5MHz)	5MHz	QPSK / 16QAM / 64QAM / 256QAM	1 RB / 0 RB Offset 1 RB / 12 RB Offset 1 RB / 24 RB Offset 12 RB / 0 RB Offset 12 RB / 6 RB Offset 12 RB / 13 RB Offset 25 RB / 0 RB Offset
	43140 to 43540	43140 (3555.0MHz), 43340 (3575.0MHz), 43540 (3595.0MHz)	10MHz	QPSK / 16QAM / 64QAM / 256QAM	1 RB / 0 RB Offset 1 RB / 24 RB Offset 1 RB / 49 RB Offset 25 RB / 0 RB Offset 25 RB / 12 RB Offset 25 RB / 25 RB Offset 50 RB / 0 RB Offset
	43165 to 43515	43165 (3557.5MHz), 43340 (3575.0MHz), 43515 (3592.5MHz)	15MHz	QPSK / 16QAM / 64QAM / 256QAM	1 RB / 0 RB Offset 1 RB / 37 RB Offset 1 RB / 74 RB Offset 36 RB / 0 RB Offset 36 RB / 19 RB Offset 36 RB / 39 RB Offset 75 RB / 0 RB Offset
	43190 to 43490	43190 (3560.0MHz), 43340 (3575.0MHz), 43490 (3590.0MHz)	20MHz	QPSK / 16QAM / 64QAM / 256QAM	1 RB / 0 RB Offset 1 RB / 50 RB Offset 1 RB / 99 RB Offset 50 RB / 0 RB Offset 50 RB / 25 RB Offset 50 RB / 50 RB Offset 100 RB / 0 RB Offset

**Test Condition:**

Test Item	Environmental Conditions	Input Power	Tested By
Maximum Output Power	25deg. C, 70%RH	5Vdc	James Yang
Radiated Emission	22deg. C, 65%RH 22deg. C, 68%RH	120Vac, 60Hz	Greg Lin

### 3.3 Description of Support Units

The EUT has been tested as an independent unit together with other necessary accessories or support units. The following support units or accessories were used to form a representative test configuration during the tests.

ID	Product	Brand	Model No.	Serial No.	FCC ID	Remarks
A.	Wideband Radio Communication Tester	R&S	CMW500	151084	NA	-
B.	Adapter	LITEON	PA-1050-39	NA	NA	-
C.	Fixture	NA	NA	NA	NA	Provided by client.

Note:

1. All power cords of the above support units are non-shielded (1.8m).
2. Items A acted as communication partners to transfer data.

ID	Descriptions	Qty.	Length (m)	Shielding (Yes/No)	Cores (Qty.)	Remarks
1.	USB cable	1	1.5	Y	0	-

#### 3.3.1 Configuration of System under Test

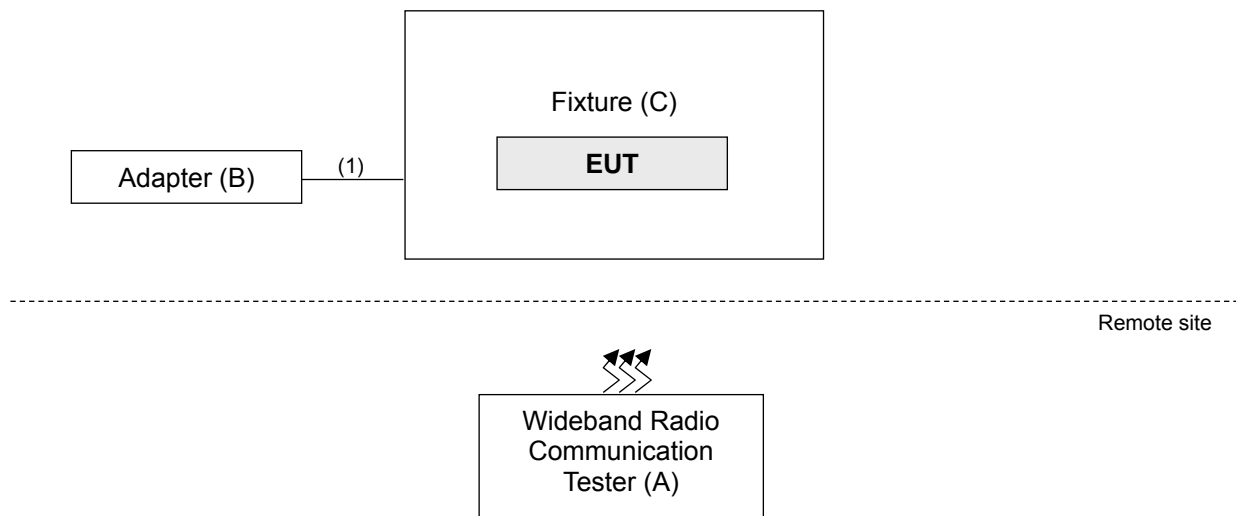

### **3.4 General Description of Applied Standards and References**

The EUT is a RF Product. According to the specifications of the manufacturer, it must comply with the requirements of the following standards and References:

**Test Standard:**

**FCC 47 CFR Part 2**

**FCC 47 CFR Part 96**

**ANSI/TIA/EIA-603-D-2010**

All test items have been performed and recorded as per the above standards.

**References Test Guidance:**

**KDB 971168 D01 Power Meas License Digital Systems v03r01**

**KDB 662911 D01 Multiple Transmitter Output v02r01**

**KDB 940660 D01 Part 96 CBRS Eqpt v02**

All test items have been performed as a reference to the above KDB test guidance.

## 4 Test Types and Results

### 4.1 Maximum Output Power Measurement

#### 4.1.1 Limits of Maximum Output Power Measurement

Device		Maximum Output Power (dBm/10 MHz)
<input checked="" type="checkbox"/>	End User Device	23
<input type="checkbox"/>	Category A CBSD	30
<input type="checkbox"/>	Category B CBSD	47

#### 4.1.2 Test Setup

Conducted Measurement Method

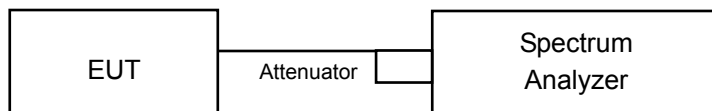

## 4.1.3 Test Instruments

Description & Manufacturer	Model No.	Serial No.	Cal. Date	Cal. Due
Test Receiver KEYSIGHT	N9038A	MY55420137	Apr. 16, 2020	Apr. 15, 2021
Spectrum Analyzer ROHDE & SCHWARZ	FSP40	100039	Jun. 12, 2020	Jun. 11, 2021
BILOG Antenna SCHWARZBECK	VULB9168	9168-160	Nov. 07, 2019	Nov. 06, 2020
HORN Antenna SCHWARZBECK	BBHA 9120 D	9120D-1169	Nov. 24, 2019	Nov. 23, 2020
HORN Antenna SCHWARZBECK	BBHA 9170	BBHA9170241	Nov. 24, 2019	Nov. 23, 2020
Preamplifier Agilent (Below 1GHz)	8447D	2944A10638	Jun. 08, 2020	Jun. 07, 2021
Preamplifier Agilent (Above 1GHz)	8449B	3008A02367	Feb. 18, 2020	Feb. 17, 2021
RF signal cable HUBER+SUHNER&EMCI	SUCOFLEX 104 & EMC104-SM-SM80 00	CABLE-CH9-02 (248780+171006)	Jan. 18, 2020	Jan. 17, 2021
RF signal cable HUBER+SUHNER	SUCOFLEX 104	CABLE-CH9-(250795/4)	Jan. 18, 2020	Jan. 17, 2021
RF signal cable Woken	8D-FB	Cable-CH9-01	Jun. 08, 2020	Jun. 07, 2021
Software BV ADT	ADT_Radiated_ V7.6.15.9.5	NA	NA	NA
Antenna Tower EMCO	2070/2080	512.835.4684	NA	NA
Turn Table EMCO	2087-2.03	NA	NA	NA
Antenna Tower & Turn BV ADT	AT100	AT93021705	NA	NA
Turn Table BV ADT	TT100	TT93021705	NA	NA
Turn Table Controller BV ADT	SC100	SC93021705	NA	NA
Boresight Antenna Fixture	FBA-01	FBA-SIP01	NA	NA
WIT Standard Temperature And Humidity Chamber	TH-4S-C	W981030	Jun. 01, 2020	May 31, 2021
JFW 20dB attenuation	50HF-020-SMA	NA	NA	NA
True RMS Clamp Meter Fluke	325	31130711WS	Jun. 06, 2020	Jun. 05, 2021
DC power supply	U8002A	MY56330015	NA	NA

Note: 1. The calibration interval of the above test instruments is 12 months and the calibrations are traceable to NML/ROC and NIST/USA.

2. The test was performed in HwaYa Chamber 9.

#### 4.1.4 Test Procedures

##### Conducted output power measurement

1. Connect the DUT transmitter output to the spectrum analyzer via coaxial cable while ensuring proper impedance matching.
2. Set span to at least 1.5 times the OBW.
3. Set RBW = 1-5% of the OBW, not to exceed 1 MHz.
4. Set VBW  $\geq 3 \times$  RBW.
5. Set number of points in sweep  $\geq 2 \times$  span / RBW.
6. Sweep time = auto-couple.
7. Detector = RMS (power averaging).
8. If the EUT can be configured to transmit continuously (i.e., burst duty cycle  $\geq 98\%$ ), then set the trigger to free run.
9. If the EUT cannot be configured to transmit continuously (i.e., burst duty cycle  $< 98\%$ ), then use a sweep trigger with the level set to enable triggering only on full power bursts and configure the EUT to transmit at full power for the entire duration of each sweep. Ensure that the sweep time is less than or equal to the transmission burst duration.
10. Trace average at least 100 traces in power averaging (i.e., RMS) mode.
11. Compute the power by integrating the spectrum across the OBW of the signal using the instrument's band or channel power measurement function, with the band/channel limits set equal to the OBW band edges. If the instrument does not have a band or channel power function, then sum the spectrum levels (in linear power units) at intervals equal to the RBW extending across the entire OBW of the spectrum.
12. For per 10MHz method, channel power integrating bandwidth 10MHz is used for bandwidth 5M, 10M, 15M and 20M. 13. For full power method, channel power integrating bandwidth 10MHz is used for bandwidth 5M, 10M, integrating bandwidth 15MHz is used for bandwidth 15M, integrating bandwidth 20MHz is used for bandwidth 20M.

##### Maximum EIRP

The relevant equation for determining the maximum ERP or EIRP from the measured RF output power is given in Equation as follows:

$$\text{ERP or EIRP} = P_{\text{Meas}} + G_{\text{T}}$$

where

ERP or EIRP effective radiated power or equivalent isotropically radiated power, respectively  
(expressed in the same units as  $P_{\text{Meas}}$ , e.g., dBm or dBW)

$P_{\text{Meas}}$  measured transmitter output power or PSD, in dBm or dBW

$G_{\text{T}}$  gain of the transmitting antenna, in dBd (ERP) or dBi (EIRP)

#### 4.1.5 Deviation from Test Standard

No deviation.

#### 4.1.6 EUT Operating Conditions

The software provided by client to enable the EUT under transmission condition continuously at lowest, middle and highest channel frequencies individually.



## 4.1.7 Test Results

## Conducted Output Power (dBm) / Per 10M

Band / BW	RB Size	RB Offset	QPSK			16QAM			64QAM			256QAM		
			Low CH	Mid CH	High CH	Low CH	Mid CH	High CH	Low CH	Mid CH	High CH	Low CH	Mid CH	High CH
			55265	55990	56715	55265	55990	56715	55265	55990	56715	55265	55990	56715
			3552.5	3625	3697.5	3552.5	3625	3697.5	3552.5	3625	3697.5	3552.5	3625	3697.5
			MHz	MHz	MHz	MHz	MHz	MHz	MHz	MHz	MHz	MHz	MHz	MHz
48 / 5M	1	0	20.93	21.02	20.91	20.16	20.15	20.34	19.02	19.12	19.14	17.34	17.04	17.86
	1	12	20.86	20.83	20.89	20.23	20.24	20.35	18.97	18.98	18.99	17.01	17.15	17.43
	1	24	20.88	20.92	21.01	20.31	20.30	20.23	18.98	19.07	19.05	17.06	17.64	17.40
	12	0	20.08	20.06	20.13	19.04	19.09	19.16	18.21	18.12	18.11	16.74	16.44	16.58
	12	6	20.10	20.06	20.07	19.14	19.18	19.04	18.16	18.12	18.18	16.35	16.77	16.67
	12	13	20.01	19.94	20.07	18.97	19.17	19.11	18.13	18.12	18.26	16.48	16.31	16.65
	25	0	19.99	20.09	20.05	19.11	19.04	19.18	18.03	18.13	18.24	16.25	16.67	16.28

Band / BW	RB Size	RB Offset	QPSK			16QAM			64QAM			256QAM		
			Low CH	Mid CH	High CH	Low CH	Mid CH	High CH	Low CH	Mid CH	High CH	Low CH	Mid CH	High CH
			55290	55990	56690	55290	55990	56690	55290	55990	56690	55290	55990	56690
			3555	3625	3695	3555	3625	3695	3555	3625	3695	3555	3625	3695
			MHz	MHz	MHz	MHz	MHz	MHz	MHz	MHz	MHz	MHz	MHz	MHz
48 / 10M	1	0	21.05	21.08	21.00	20.20	20.21	20.32	19.21	19.35	19.26	17.32	17.65	17.94
	1	12	21.07	21.03	20.80	20.28	20.15	20.24	19.16	18.98	19.09	17.29	17.12	17.50
	1	24	20.86	20.96	20.96	20.22	20.28	20.22	19.03	19.07	19.25	17.10	17.46	17.45
	12	0	20.11	20.15	20.07	19.04	19.18	19.11	18.17	18.22	18.33	16.32	16.86	16.50
	12	6	20.01	20.01	20.07	19.14	19.11	19.20	18.34	18.32	18.26	16.62	16.68	16.84
	12	13	19.93	19.93	20.17	19.12	19.17	19.00	18.04	18.16	18.25	16.41	16.24	16.56
	25	0	20.00	19.98	20.03	19.03	19.18	19.20	18.08	18.22	18.15	16.19	16.74	16.25

Band / BW	RB Size	RB Offset	QPSK			16QAM			64QAM			256QAM		
			Low CH	Mid CH	High CH	Low CH	Mid CH	High CH	Low CH	Mid CH	High CH	Low CH	Mid CH	High CH
			55315	55990	56665	55315	55990	56665	55315	55990	56665	55315	55990	56665
			3557.5	3625	3692.5	3557.5	3625	3692.5	3557.5	3625	3692.5	3557.5	3625	3692.5
			MHz	MHz	MHz	MHz	MHz	MHz	MHz	MHz	MHz	MHz	MHz	MHz
48 / 15M	1	0	21.66	20.88	20.94	20.67	20.27	20.08	19.58	19.00	19.40	17.68	17.98	17.90
	1	12	21.52	20.88	21.13	20.45	20.14	20.05	19.51	18.83	18.97	17.95	17.26	17.54
	1	24	21.47	20.73	20.72	20.33	20.09	19.96	19.63	19.00	19.02	17.79	17.08	17.40
	12	0	19.86	19.38	19.11	18.85	18.31	18.16	17.87	17.44	17.26	16.00	15.50	15.45
	12	6	19.75	19.29	19.17	18.75	18.27	18.17	17.92	17.33	17.17	15.93	15.83	15.32
	12	13	19.67	19.13	19.30	18.62	18.16	18.11	17.75	17.32	17.28	15.93	15.44	15.38
	25	0	18.25	17.91	17.67	17.33	16.87	16.73	16.33	15.90	15.81	14.74	14.18	14.20

Band / BW	RB Size	RB Offset	QPSK			16QAM			64QAM			256QAM		
			Low CH	Mid CH	High CH	Low CH	Mid CH	High CH	Low CH	Mid CH	High CH	Low CH	Mid CH	High CH
			55340	55990	56640	55340	55990	56640	55340	55990	56640	55340	55990	56640
			3560	3625	3690	3560	3625	3690	3560	3625	3690	3560	3625	3690
			MHz	MHz	MHz	MHz	MHz	MHz	MHz	MHz	MHz	MHz	MHz	MHz
48 / 20M	1	0	21.52	21.00	21.28	20.37	19.93	19.80	19.67	19.19	18.98	17.78	17.38	17.19
	1	12	21.16	20.79	20.99	20.30	19.88	19.75	19.34	19.11	18.75	17.61	17.14	16.95
	1	24	21.25	20.59	20.70	20.20	19.99	19.73	19.39	19.20	18.95	17.67	17.32	17.29
	12	0	19.74	19.27	19.12	18.78	18.37	18.32	17.70	17.36	17.22	15.87	15.78	15.61
	12	6	19.63	19.29	19.28	18.56	18.26	18.15	17.76	17.27	17.26	16.12	15.74	15.68
	12	13	19.60	19.25	19.17	18.63	18.22	18.29	17.58	17.18	17.27	15.72	15.61	15.82
	25	0	17.10	16.78	16.63	16.11	15.71	15.70	15.12	14.81	14.65	13.25	13.02	12.93

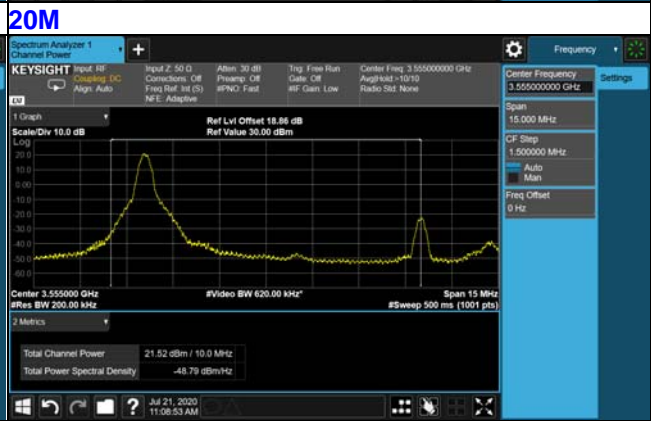
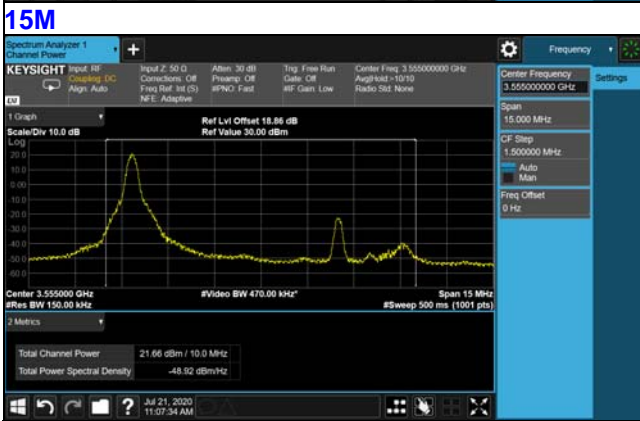
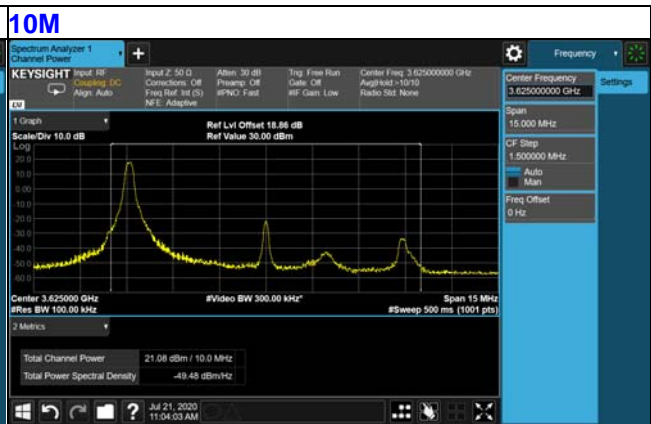
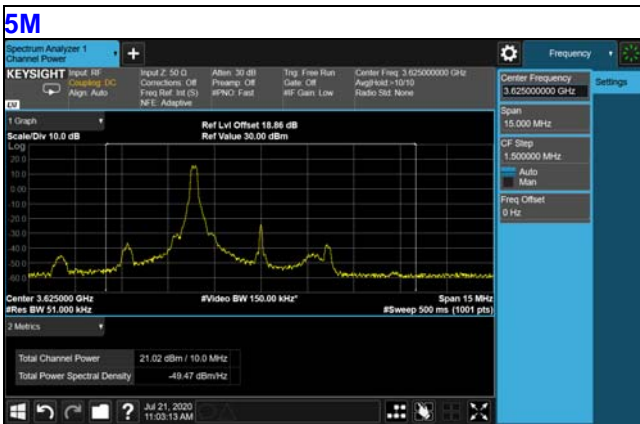

**EIRP Power(dBm) / Per 10M**

Band / BW	RB Size	RB Offset	QPSK			16QAM			64QAM			256QAM		
			Low CH	Mid CH	High CH	Low CH	Mid CH	High CH	Low CH	Mid CH	High CH	Low CH	Mid CH	High CH
			55265	55990	56715	55265	55990	56715	55265	55990	56715	55265	55990	56715
			3552.5	3625	3697.5	3552.5	3625	3697.5	3552.5	3625	3697.5	3552.5	3625	3697.5
			MHz	MHz	MHz	MHz	MHz	MHz	MHz	MHz	MHz	MHz	MHz	MHz
48 / 5M	1	0	21.85	<b>21.94</b>	21.83	21.08	21.07	21.26	19.94	20.04	<b>20.06</b>	18.26	17.96	<b>18.78</b>
	1	12	21.78	21.75	21.81	21.15	21.16	<b>21.27</b>	19.89	19.90	19.91	17.93	18.07	18.35
	1	24	21.80	21.84	21.93	21.23	21.22	21.15	19.90	19.99	19.97	17.98	18.56	18.32
	12	0	21.00	20.98	21.05	19.96	20.01	20.08	19.13	19.04	19.03	17.66	17.36	17.50
	12	6	21.02	20.98	20.99	20.06	20.10	19.96	19.08	19.04	19.10	17.27	17.69	17.59
	12	13	20.93	20.86	20.99	19.89	20.09	20.03	19.05	19.04	19.18	17.40	17.23	17.57
	25	0	20.91	21.01	20.97	20.03	19.96	20.10	18.95	19.05	19.16	17.17	17.59	17.20

Band / BW	RB Size	RB Offset	QPSK			16QAM			64QAM			256QAM		
			Low CH	Mid CH	High CH	Low CH	Mid CH	High CH	Low CH	Mid CH	High CH	Low CH	Mid CH	High CH
			55290	55990	56690	55290	55990	56690	55290	55990	56690	55290	55990	56690
			3555	3625	3695	3555	3625	3695	3555	3625	3695	3555	3625	3695
			MHz	MHz	MHz	MHz	MHz	MHz	MHz	MHz	MHz	MHz	MHz	MHz
48 / 10M	1	0	21.97	<b>22.00</b>	21.92	21.12	21.13	<b>21.24</b>	20.13	<b>20.27</b>	20.18	18.24	18.57	<b>18.86</b>
	1	12	21.99	21.95	21.72	21.20	21.07	21.16	20.08	19.90	20.01	18.21	18.04	18.42
	1	24	21.78	21.88	21.88	21.14	21.20	21.14	19.95	19.99	20.17	18.02	18.38	18.37
	12	0	21.03	21.07	20.99	19.96	20.10	20.03	19.09	19.14	19.25	17.24	17.78	17.42
	12	6	20.93	20.93	20.99	20.06	20.03	20.12	19.26	19.24	19.18	17.54	17.60	17.76
	12	13	20.85	20.85	21.09	20.04	20.09	19.92	18.96	19.08	19.17	17.33	17.16	17.48
	25	0	20.92	20.90	20.95	19.95	20.10	20.12	19.00	19.14	19.07	17.11	17.66	17.17

Band / BW	RB Size	RB Offset	QPSK			16QAM			64QAM			256QAM		
			Low CH	Mid CH	High CH	Low CH	Mid CH	High CH	Low CH	Mid CH	High CH	Low CH	Mid CH	High CH
			55315	55990	56665	55315	55990	56665	55315	55990	56665	55315	55990	56665
			3557.5	3625	3692.5	3557.5	3625	3692.5	3557.5	3625	3692.5	3557.5	3625	3692.5
			MHz	MHz	MHz	MHz	MHz	MHz	MHz	MHz	MHz	MHz	MHz	MHz
48 / 15M	1	0	<b>22.58</b>	21.80	21.86	<b>21.59</b>	21.19	21.00	20.50	19.92	20.32	18.60	<b>18.90</b>	18.82
	1	12	22.44	21.80	22.05	21.37	21.06	20.97	20.43	19.75	19.89	18.87	18.18	18.46
	1	24	22.39	21.65	21.64	21.25	21.01	20.88	<b>20.55</b>	19.92	19.94	18.71	18.00	18.32
	12	0	20.78	20.30	20.03	19.77	19.23	19.08	18.79	18.36	18.18	16.92	16.42	16.37
	12	6	20.67	20.21	20.09	19.67	19.19	19.09	18.84	18.25	18.09	16.85	16.75	16.24
	12	13	20.59	20.05	20.22	19.54	19.08	19.03	18.67	18.24	18.20	16.85	16.36	16.30
	25	0	19.17	18.83	18.59	18.25	17.79	17.65	17.25	16.82	16.73	15.66	15.10	15.12

\*EIRP = Conducted + antenna gain(0.92dBi).

Band / BW	RB Size	RB Offset	QPSK			16QAM			64QAM			256QAM		
			Low CH	Mid CH	High CH	Low CH	Mid CH	High CH	Low CH	Mid CH	High CH	Low CH	Mid CH	High CH
			55340	55990	56640	55340	55990	56640	55340	55990	56640	55340	55990	56640
			3560	3625	3690	3560	3625	3690	3560	3625	3690	3560	3625	3690
			MHz	MHz	MHz	MHz	MHz	MHz	MHz	MHz	MHz	MHz	MHz	MHz
48 / 20M	1	0	22.44	21.92	22.20	21.29	20.85	20.72	20.59	20.11	19.90	18.70	18.30	18.11
	1	12	22.08	21.71	21.91	21.22	20.80	20.67	20.26	20.03	19.67	18.53	18.06	17.87
	1	24	22.17	21.51	21.62	21.12	20.91	20.65	20.31	20.12	19.87	18.59	18.24	18.21
	12	0	20.66	20.19	20.04	19.70	19.29	19.24	18.62	18.28	18.14	16.79	16.70	16.53
	12	6	20.55	20.21	20.20	19.48	19.18	19.07	18.68	18.19	18.18	17.04	16.66	16.60
	12	13	20.52	20.17	20.09	19.55	19.14	19.21	18.50	18.10	18.19	16.64	16.53	16.74
	25	0	18.02	17.70	17.55	17.03	16.63	16.62	16.04	15.73	15.57	14.17	13.94	13.85

\*EIRP = Conducted + antenna gain(0.92dBi).

**Conducted Output Power (dBm) / Full Power**

Band / BW	RB Size	RB Offset	QPSK			16QAM			64QAM			256QAM		
			Low CH	Mid CH	High CH	Low CH	Mid CH	High CH	Low CH	Mid CH	High CH	Low CH	Mid CH	High CH
			55265	55990	56715	55265	55990	56715	55265	55990	56715	55265	55990	56715
			3552.5	3625	3697.5	3552.5	3625	3697.5	3552.5	3625	3697.5	3552.5	3625	3697.5
			MHz	MHz	MHz	MHz	MHz	MHz	MHz	MHz	MHz	MHz	MHz	MHz
48 / 5M	1	0	20.93	21.02	20.91	20.16	20.15	20.34	19.02	19.12	19.14	17.34	17.04	17.86
	1	12	20.86	20.83	20.89	20.23	20.24	20.35	18.97	18.98	18.99	17.01	17.15	17.43
	1	24	20.88	20.92	21.01	20.31	20.30	20.23	18.98	19.07	19.05	17.06	17.64	17.40
	12	0	20.08	20.06	20.13	19.04	19.09	19.16	18.21	18.12	18.11	16.74	16.44	16.58
	12	6	20.10	20.06	20.07	19.14	19.18	19.04	18.16	18.12	18.18	16.35	16.77	16.67
	12	13	20.01	19.94	20.07	18.97	19.17	19.11	18.13	18.12	18.26	16.48	16.31	16.65
	25	0	19.99	20.09	20.05	19.11	19.04	19.18	18.03	18.13	18.24	16.25	16.67	16.28

Band / BW	RB Size	RB Offset	QPSK			16QAM			64QAM			256QAM		
			Low CH	Mid CH	High CH	Low CH	Mid CH	High CH	Low CH	Mid CH	High CH	Low CH	Mid CH	High CH
			55290	55990	56690	55290	55990	56690	55290	55990	56690	55290	55990	56690
			3555	3625	3695	3555	3625	3695	3555	3625	3695	3555	3625	3695
			MHz	MHz	MHz	MHz	MHz	MHz	MHz	MHz	MHz	MHz	MHz	MHz
48 / 10M	1	0	21.05	21.08	21.00	20.20	20.21	20.32	19.21	19.35	19.26	17.32	17.65	17.94
	1	12	21.07	21.03	20.80	20.28	20.15	20.24	19.16	18.98	19.09	17.29	17.12	17.50
	1	24	20.86	20.96	20.96	20.22	20.28	20.22	19.03	19.07	19.25	17.10	17.46	17.45
	12	0	20.11	20.15	20.07	19.04	19.18	19.11	18.17	18.22	18.33	16.32	16.86	16.50
	12	6	20.01	20.01	20.07	19.14	19.11	19.20	18.34	18.32	18.26	16.62	16.68	16.84
	12	13	19.93	19.93	20.17	19.12	19.17	19.00	18.04	18.16	18.25	16.41	16.24	16.56
	25	0	20.00	19.98	20.03	19.03	19.18	19.20	18.08	18.22	18.15	16.19	16.74	16.25

Band / BW	RB Size	RB Offset	QPSK			16QAM			64QAM			256QAM		
			Low CH	Mid CH	High CH	Low CH	Mid CH	High CH	Low CH	Mid CH	High CH	Low CH	Mid CH	High CH
			55315	55990	56665	55315	55990	56665	55315	55990	56665	55315	55990	56665
			3557.5	3625	3692.5	3557.5	3625	3692.5	3557.5	3625	3692.5	3557.5	3625	3692.5
			MHz	MHz	MHz	MHz	MHz	MHz	MHz	MHz	MHz	MHz	MHz	MHz
48 / 15M	1	0	21.63	21.65	21.51	20.93	20.95	20.92	19.76	19.70	19.80	17.75	18.09	17.84
	1	12	21.50	21.56	21.55	20.75	20.99	20.86	19.53	19.60	19.61	17.86	18.05	17.79
	1	24	21.53	21.51	21.59	20.92	20.97	20.96	19.55	19.80	19.94	17.71	17.81	17.88
	12	0	20.69	20.77	20.82	19.74	19.90	19.89	18.66	18.81	18.90	17.42	17.59	17.27
	12	6	20.77	20.74	20.78	19.80	19.87	19.75	18.75	18.86	18.89	17.02	17.34	17.25
	12	13	20.70	20.65	20.79	19.64	19.67	19.74	18.68	18.69	18.97	16.76	17.47	17.24
	25	0	20.67	20.69	20.78	19.75	19.82	19.93	18.68	18.72	18.82	16.67	16.92	17.28

Band / BW	RB Size	RB Offset	QPSK			16QAM			64QAM			256QAM		
			Low CH	Mid CH	High CH	Low CH	Mid CH	High CH	Low CH	Mid CH	High CH	Low CH	Mid CH	High CH
			55340	55990	56640	55340	55990	56640	55340	55990	56640	55340	55990	56640
			3560	3625	3690	3560	3625	3690	3560	3625	3690	3560	3625	3690
			MHz	MHz	MHz	MHz	MHz	MHz	MHz	MHz	MHz	MHz	MHz	MHz
48 / 20M	1	0	21.53	21.73	21.71	20.99	21.13	21.11	19.75	19.82	19.73	18.04	18.05	17.85
	1	12	21.44	21.70	21.65	20.85	21.04	20.90	19.66	19.68	19.57	17.75	17.84	18.02
	1	24	21.48	21.72	21.48	20.86	21.11	20.98	19.49	19.82	19.79	17.89	17.85	17.83
	12	0	20.65	20.86	20.81	19.85	19.94	19.80	18.78	18.95	18.93	17.38	17.12	17.58
	12	6	20.56	20.73	20.83	19.77	19.95	19.84	18.73	18.88	18.85	17.00	17.45	17.11
	12	13	20.59	20.77	20.90	19.78	19.77	19.89	18.68	18.86	18.86	17.13	17.62	17.12
	25	0	20.73	20.71	20.71	19.65	19.91	19.93	18.73	18.86	18.89	16.73	16.90	16.96

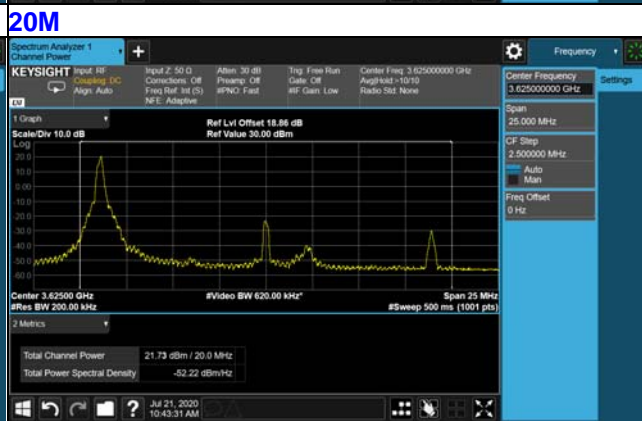
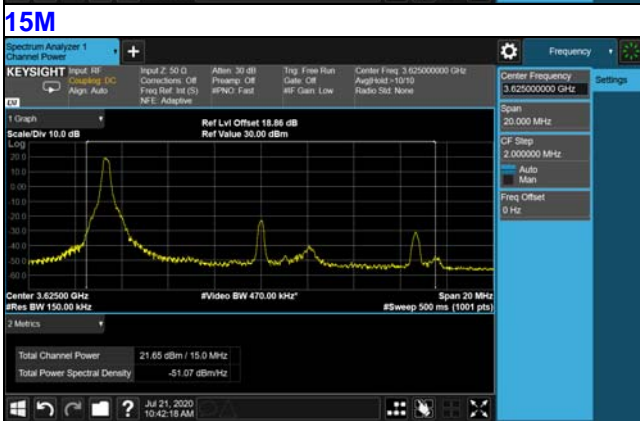
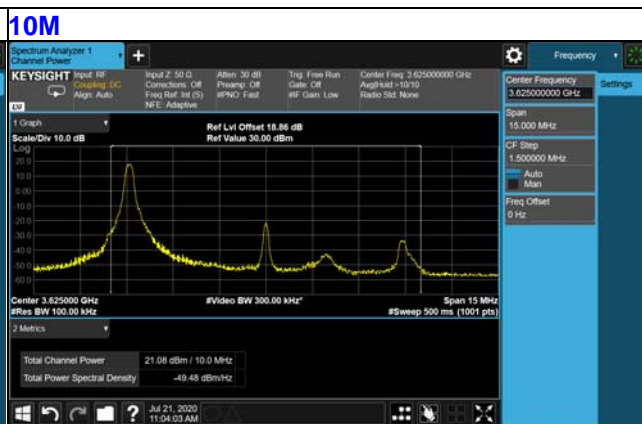
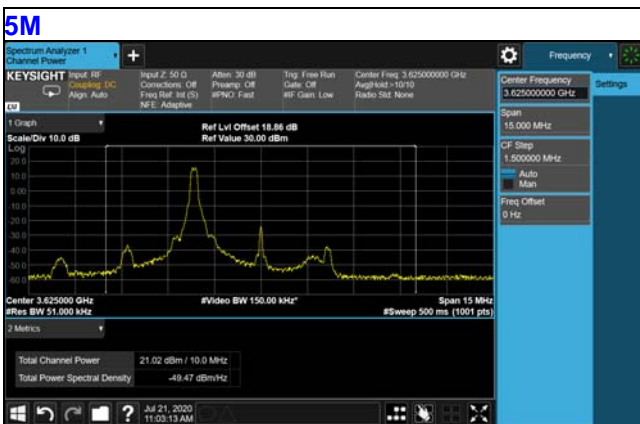

**EIRP Power (dBm) / Full Power**

Band / BW	RB Size	RB Offset	QPSK			16QAM			64QAM			256QAM		
			Low CH	Mid CH	High CH	Low CH	Mid CH	High CH	Low CH	Mid CH	High CH	Low CH	Mid CH	High CH
			55265	55990	56715	55265	55990	56715	55265	55990	56715	55265	55990	56715
			3552.5	3625	3697.5	3552.5	3625	3697.5	3552.5	3625	3697.5	3552.5	3625	3697.5
			MHz	MHz	MHz	MHz	MHz	MHz	MHz	MHz	MHz	MHz	MHz	MHz
48 / 5M	1	0	21.85	<b>21.94</b>	21.83	21.08	21.07	21.26	19.94	20.04	<b>20.06</b>	18.26	17.96	<b>18.78</b>
	1	12	21.78	21.75	21.81	21.15	21.16	<b>21.27</b>	19.89	19.90	19.91	17.93	18.07	18.35
	1	24	21.80	21.84	21.93	21.23	21.22	21.15	19.90	19.99	19.97	17.98	18.56	18.32
	12	0	21.00	20.98	21.05	19.96	20.01	20.08	19.13	19.04	19.03	17.66	17.36	17.50
	12	6	21.02	20.98	20.99	20.06	20.10	19.96	19.08	19.04	19.10	17.27	17.69	17.59
	12	13	20.93	20.86	20.99	19.89	20.09	20.03	19.05	19.04	19.18	17.40	17.23	17.57
	25	0	20.91	21.01	20.97	20.03	19.96	20.10	18.95	19.05	19.16	17.17	17.59	17.20

Band / BW	RB Size	RB Offset	QPSK			16QAM			64QAM			256QAM		
			Low CH	Mid CH	High CH	Low CH	Mid CH	High CH	Low CH	Mid CH	High CH	Low CH	Mid CH	High CH
			55290	55990	56690	55290	55990	56690	55290	55990	56690	55290	55990	56690
			3555	3625	3695	3555	3625	3695	3555	3625	3695	3555	3625	3695
			MHz	MHz	MHz	MHz	MHz	MHz	MHz	MHz	MHz	MHz	MHz	MHz
48 / 10M	1	0	21.97	<b>22.00</b>	21.92	21.12	21.13	<b>21.24</b>	20.13	<b>20.27</b>	20.18	18.24	18.57	<b>18.86</b>
	1	12	21.99	21.95	21.72	21.20	21.07	21.16	20.08	19.90	20.01	18.21	18.04	18.42
	1	24	21.78	21.88	21.88	21.14	21.20	21.14	19.95	19.99	20.17	18.02	18.38	18.37
	12	0	21.03	21.07	20.99	19.96	20.10	20.03	19.09	19.14	19.25	17.24	17.78	17.42
	12	6	20.93	20.93	20.99	20.06	20.03	20.12	19.26	19.24	19.18	17.54	17.60	17.76
	12	13	20.85	20.85	21.09	20.04	20.09	19.92	18.96	19.08	19.17	17.33	17.16	17.48
	25	0	20.92	20.90	20.95	19.95	20.10	20.12	19.00	19.14	19.07	17.11	17.66	17.17

Band / BW	RB Size	RB Offset	QPSK			16QAM			64QAM			256QAM		
			Low CH	Mid CH	High CH	Low CH	Mid CH	High CH	Low CH	Mid CH	High CH	Low CH	Mid CH	High CH
			55315	55990	56665	55315	55990	56665	55315	55990	56665	55315	55990	56665
			3557.5	3625	3692.5	3557.5	3625	3692.5	3557.5	3625	3692.5	3557.5	3625	3692.5
			MHz	MHz	MHz	MHz	MHz	MHz	MHz	MHz	MHz	MHz	MHz	MHz
48 / 15M	1	0	22.55	<b>22.57</b>	22.43	21.85	21.87	21.84	20.68	20.62	20.72	18.67	<b>19.01</b>	18.76
	1	12	22.42	22.48	22.47	21.67	<b>21.91</b>	21.78	20.45	20.52	20.53	18.78	18.97	18.71
	1	24	22.45	22.43	22.51	21.84	21.89	21.88	20.47	20.72	<b>20.86</b>	18.63	18.73	18.80
	12	0	21.61	21.69	21.74	20.66	20.82	20.81	19.58	19.73	19.82	18.34	18.51	18.19
	12	6	21.69	21.66	21.70	20.72	20.79	20.67	19.67	19.78	19.81	17.94	18.26	18.17
	12	13	21.62	21.57	21.71	20.56	20.59	20.66	19.60	19.61	19.89	17.68	18.39	18.16
	25	0	21.59	21.61	21.70	20.67	20.74	20.85	19.60	19.64	19.74	17.59	17.84	18.20

\*EIRP = Conducted + antenna gain(0.92dBi).

Band / BW	RB Size	RB Offset	QPSK			16QAM			64QAM			256QAM		
			Low CH	Mid CH	High CH	Low CH	Mid CH	High CH	Low CH	Mid CH	High CH	Low CH	Mid CH	High CH
			55340	55990	56640	55340	55990	56640	55340	55990	56640	55340	55990	56640
			3560	3625	3690	3560	3625	3690	3560	3625	3690	3560	3625	3690
			MHz	MHz	MHz	MHz	MHz	MHz	MHz	MHz	MHz	MHz	MHz	MHz
48 / 20M	1	0	22.45	22.65	22.63	21.91	22.05	22.03	20.67	20.74	20.65	18.96	18.97	18.77
	1	12	22.36	22.62	22.57	21.77	21.96	21.82	20.58	20.60	20.49	18.67	18.76	18.94
	1	24	22.40	22.64	22.40	21.78	22.03	21.90	20.41	20.74	20.71	18.81	18.77	18.75
	12	0	21.57	21.78	21.73	20.77	20.86	20.72	19.70	19.87	19.85	18.30	18.04	18.50
	12	6	21.48	21.65	21.75	20.69	20.87	20.76	19.65	19.80	19.77	17.92	18.37	18.03
	12	13	21.51	21.69	21.82	20.70	20.69	20.81	19.60	19.78	19.78	18.05	18.54	18.04
	25	0	21.65	21.63	21.63	20.57	20.83	20.85	19.65	19.78	19.81	17.65	17.82	17.88

\*EIRP = Conducted + antenna gain(0.92dBi).



**Conducted Output Power (dBm) / Per 10M**

Band / BW	RB Size	RB Offset	QPSK			16QAM			64QAM			256QAM		
			Low CH	Mid CH	High CH	Low CH	Mid CH	High CH	Low CH	Mid CH	High CH	Low CH	Mid CH	High CH
			43115	43340	43565	43115	43340	43565	43115	43340	43565	43115	43340	43565
			3552.5	3575	3597.5	3552.5	3575	3597.5	3552.5	3575	3597.5	3552.5	3575	3597.5
			MHz	MHz	MHz	MHz	MHz	MHz	MHz	MHz	MHz	MHz	MHz	MHz
42 / 5M	1	0	20.70	20.68	20.46	19.93	19.68	19.88	18.82	18.59	18.63	17.04	16.97	17.00
	1	12	20.61	20.64	20.60	19.81	19.95	19.77	18.38	18.57	18.71	16.74	17.03	16.79
	1	24	20.68	20.59	20.54	19.73	19.73	19.78	18.58	18.69	18.77	17.23	17.10	17.18
	12	0	19.64	19.75	19.93	18.61	18.66	18.60	17.86	17.80	17.83	16.11	16.39	16.23
	12	6	19.86	19.74	19.79	18.82	18.78	18.84	17.73	17.83	17.85	16.33	16.39	16.12
	12	13	19.59	19.49	19.81	18.64	18.66	18.58	17.91	17.49	17.86	16.26	16.42	16.07
	25	0	19.76	19.83	19.78	18.67	18.69	18.71	17.85	17.95	17.88	16.02	15.96	16.13

Band / BW	RB Size	RB Offset	QPSK			16QAM			64QAM			256QAM		
			Low CH	Mid CH	High CH	Low CH	Mid CH	High CH	Low CH	Mid CH	High CH	Low CH	Mid CH	High CH
			43140	43340	43540	43140	43340	43540	43140	43340	43540	43140	43340	43540
			3555	3575	3595	3555	3575	3595	3555	3575	3595	3555	3575	3595
			MHz	MHz	MHz	MHz	MHz	MHz	MHz	MHz	MHz	MHz	MHz	MHz
42 / 10M	1	0	20.12	19.65	19.88	19.04	19.07	19.16	18.06	17.96	17.89	15.92	16.41	16.26
	1	12	20.04	20.24	19.82	19.04	19.44	19.13	18.11	18.10	18.05	16.37	16.18	16.20
	1	24	19.84	19.84	19.89	18.99	19.00	19.26	17.81	18.10	18.17	15.99	15.88	16.05
	12	0	19.04	19.09	18.99	18.06	17.94	18.02	16.77	16.95	17.22	15.44	15.20	15.18
	12	6	18.93	19.10	18.77	18.06	18.18	17.77	17.18	17.09	17.52	15.40	15.49	15.29
	12	13	18.87	19.15	19.46	17.92	18.15	18.06	16.94	17.03	16.92	15.45	15.49	15.31
	25	0	18.80	19.04	18.81	18.11	17.89	18.09	17.18	16.89	16.88	15.21	15.27	15.10

Band / BW	RB Size	RB Offset	QPSK			16QAM			64QAM			256QAM		
			Low CH	Mid CH	High CH	Low CH	Mid CH	High CH	Low CH	Mid CH	High CH	Low CH	Mid CH	High CH
			43165	43340	43515	43165	43340	43515	43165	43340	43515	43165	43340	43515
			3557.5	3575	3592.5	3557.5	3575	3592.5	3557.5	3575	3592.5	3557.5	3575	3592.5
			MHz	MHz	MHz	MHz	MHz	MHz	MHz	MHz	MHz	MHz	MHz	MHz
42 / 15M	1	0	21.19	20.49	20.58	20.24	19.69	19.70	19.20	18.52	18.94	17.36	17.40	17.37
	1	12	20.90	20.57	20.49	19.81	19.69	19.47	19.10	18.50	18.57	17.41	16.75	17.10
	1	24	20.66	20.27	20.22	19.75	19.55	19.63	19.24	18.52	18.36	17.27	16.50	16.81
	12	0	19.27	18.77	18.62	18.15	17.83	17.53	17.24	16.78	16.70	15.55	15.12	14.87
	12	6	19.17	18.76	18.71	18.41	17.92	17.79	17.46	17.01	16.93	15.63	15.46	14.63
	12	13	19.17	18.60	18.73	18.01	17.56	17.63	17.13	16.56	16.80	15.46	15.04	14.92
	25	0	17.84	17.27	17.20	16.69	16.55	16.52	15.90	15.32	15.21	14.28	13.77	13.58

Band / BW	RB Size	RB Offset	QPSK			16QAM			64QAM			256QAM		
			Low CH	Mid CH	High CH	Low CH	Mid CH	High CH	Low CH	Mid CH	High CH	Low CH	Mid CH	High CH
			3560 MHz	3575 MHz	3590 MHz	3560 MHz	3575 MHz	3590 MHz	3560 MHz	3575 MHz	3590 MHz	3560 MHz	3575 MHz	3590 MHz
42 / 20M	1	0	21.12	<b>21.33</b>	20.94	<b>20.25</b>	19.61	19.52	<b>19.21</b>	19.03	18.73	<b>17.58</b>	17.07	16.99
	1	12	20.81	20.60	20.66	20.02	19.55	19.42	19.03	18.66	18.67	17.35	16.77	16.67
	1	24	21.01	20.14	20.48	19.81	19.64	19.47	18.96	18.99	18.83	17.23	17.09	17.01
	12	0	19.36	18.90	18.86	18.53	18.02	18.01	17.47	16.95	16.82	15.52	15.54	15.51
	12	6	19.27	18.75	18.88	18.28	18.04	17.90	17.54	17.01	17.13	15.83	15.49	15.32
	12	13	19.15	18.96	18.93	18.36	18.02	18.06	17.53	17.01	17.12	15.57	15.37	15.33
	25	0	16.60	16.41	16.33	15.84	15.27	15.55	14.83	14.51	14.44	13.02	12.75	12.58

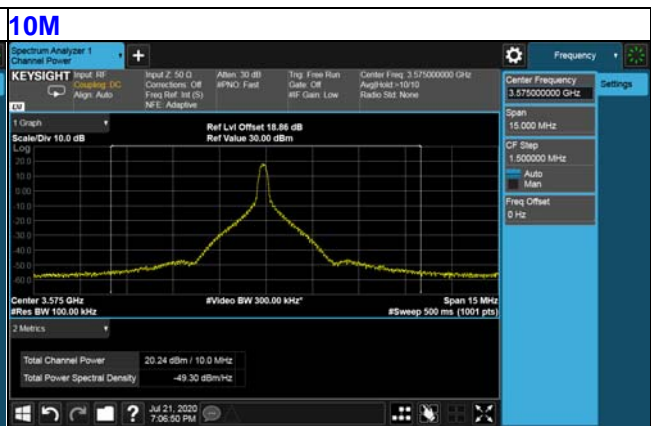
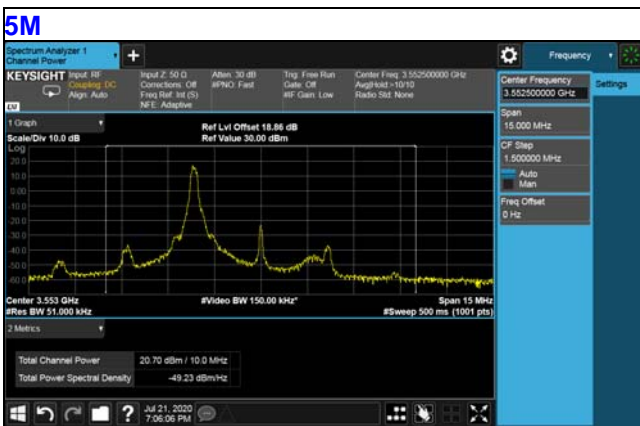

**EIRP Power(dBm) / Per 10M**

Band / BW	RB Size	RB Offset	QPSK			16QAM			64QAM			256QAM		
			Low CH	Mid CH	High CH	Low CH	Mid CH	High CH	Low CH	Mid CH	High CH	Low CH	Mid CH	High CH
			43115	43340	43565	43115	43340	43565	43115	43340	43565	43115	43340	43565
			3552.5	3575	3597.5	3552.5	3575	3597.5	3552.5	3575	3597.5	3552.5	3575	3597.5
			MHz	MHz	MHz	MHz	MHz	MHz	MHz	MHz	MHz	MHz	MHz	MHz
42 / 5M	1	0	21.62	21.60	21.38	20.85	20.60	20.80	19.74	19.51	19.55	17.96	17.89	17.92
	1	12	21.53	21.56	21.52	20.73	20.87	20.69	19.30	19.49	19.63	17.66	17.95	17.71
	1	24	21.60	21.51	21.46	20.65	20.65	20.70	19.50	19.61	19.69	18.15	18.02	18.10
	12	0	20.56	20.67	20.85	19.53	19.58	19.52	18.78	18.72	18.75	17.03	17.31	17.15
	12	6	20.78	20.66	20.71	19.74	19.70	19.76	18.65	18.75	18.77	17.25	17.31	17.04
	12	13	20.51	20.41	20.73	19.56	19.58	19.50	18.83	18.41	18.78	17.18	17.34	16.99
	25	0	20.68	20.75	20.70	19.59	19.61	19.63	18.77	18.87	18.80	16.94	16.88	17.05

Band / BW	RB Size	RB Offset	QPSK			16QAM			64QAM			256QAM		
			Low CH	Mid CH	High CH	Low CH	Mid CH	High CH	Low CH	Mid CH	High CH	Low CH	Mid CH	High CH
			43140	43340	43540	43140	43340	43540	43140	43340	43540	43140	43340	43540
			3555	3575	3595	3555	3575	3595	3555	3575	3595	3555	3575	3595
			MHz	MHz	MHz	MHz	MHz	MHz	MHz	MHz	MHz	MHz	MHz	MHz
42 / 10M	1	0	21.04	20.57	20.80	19.96	19.99	20.08	18.98	18.88	18.81	16.84	17.33	17.18
	1	12	20.96	21.16	20.74	19.96	20.36	20.05	19.03	19.02	18.97	17.29	17.10	17.12
	1	24	20.76	20.76	20.81	19.91	19.92	20.18	18.73	19.02	19.09	16.91	16.80	16.97
	12	0	19.96	20.01	19.91	18.98	18.86	18.94	17.69	17.87	18.14	16.36	16.12	16.10
	12	6	19.85	20.02	19.69	18.98	19.10	18.69	18.10	18.01	18.44	16.32	16.41	16.21
	12	13	19.79	20.07	20.38	18.84	19.07	18.98	17.86	17.95	17.84	16.37	16.41	16.23
	25	0	19.72	19.96	19.73	19.03	18.81	19.01	18.10	17.81	17.80	16.13	16.19	16.02

Band / BW	RB Size	RB Offset	QPSK			16QAM			64QAM			256QAM		
			Low CH	Mid CH	High CH	Low CH	Mid CH	High CH	Low CH	Mid CH	High CH	Low CH	Mid CH	High CH
			43165	43340	43515	43165	43340	43515	43165	43340	43515	43165	43340	43515
			3557.5	3575	3592.5	3557.5	3575	3592.5	3557.5	3575	3592.5	3557.5	3575	3592.5
			MHz	MHz	MHz	MHz	MHz	MHz	MHz	MHz	MHz	MHz	MHz	MHz
42 / 15M	1	0	22.11	21.41	21.50	21.16	20.61	20.62	20.12	19.44	19.86	18.28	18.32	18.29
	1	12	21.82	21.49	21.41	20.73	20.61	20.39	20.02	19.42	19.49	18.33	17.67	18.02
	1	24	21.58	21.19	21.14	20.67	20.47	20.55	20.16	19.44	19.28	18.19	17.42	17.73
	12	0	20.19	19.69	19.54	19.07	18.75	18.45	18.16	17.70	17.62	16.47	16.04	15.79
	12	6	20.09	19.68	19.63	19.33	18.84	18.71	18.38	17.93	17.85	16.55	16.38	15.55
	12	13	20.09	19.52	19.65	18.93	18.48	18.55	18.05	17.48	17.72	16.38	15.96	15.84
	25	0	18.76	18.19	18.12	17.61	17.47	17.44	16.82	16.24	16.13	15.20	14.69	14.50

\*EIRP = Conducted + antenna gain(0.92dBi).

Band / BW	RB Size	RB Offset	QPSK			16QAM			64QAM			256QAM		
			Low CH	Mid CH	High CH	Low CH	Mid CH	High CH	Low CH	Mid CH	High CH	Low CH	Mid CH	High CH
			43190	43340	43490	43190	43340	43490	43190	43340	43490	43190	43340	43490
			3560	3575	3590	3560	3575	3590	3560	3575	3590	3560	3575	3590
			MHz	MHz	MHz	MHz	MHz	MHz	MHz	MHz	MHz	MHz	MHz	MHz
42 / 20M	1	0	22.04	<b>22.25</b>	21.86	<b>21.17</b>	20.53	20.44	<b>20.13</b>	19.95	19.65	<b>18.50</b>	17.99	17.91
	1	12	21.73	21.52	21.58	20.94	20.47	20.34	19.95	19.58	19.59	18.27	17.69	17.59
	1	24	21.93	21.06	21.40	20.73	20.56	20.39	19.88	19.91	19.75	18.15	18.01	17.93
	12	0	20.28	19.82	19.78	19.45	18.94	18.93	18.39	17.87	17.74	16.44	16.46	16.43
	12	6	20.19	19.67	19.80	19.20	18.96	18.82	18.46	17.93	18.05	16.75	16.41	16.24
	12	13	20.07	19.88	19.85	19.28	18.94	18.98	18.45	17.93	18.04	16.49	16.29	16.25
	25	0	17.52	17.33	17.25	16.76	16.19	16.47	15.75	15.43	15.36	13.94	13.67	13.50

\*EIRP = Conducted + antenna gain(0.92dBi).

**Conducted Output Power (dBm) / Full Power**

Band / BW	RB Size	RB Offset	QPSK			16QAM			64QAM			256QAM		
			Low CH	Mid CH	High CH	Low CH	Mid CH	High CH	Low CH	Mid CH	High CH	Low CH	Mid CH	High CH
			43115	43340	43565	43115	43340	43565	43115	43340	43565	43115	43340	43565
			3552.5	3575	3597.5	3552.5	3575	3597.5	3552.5	3575	3597.5	3552.5	3575	3597.5
			MHz	MHz	MHz	MHz	MHz	MHz	MHz	MHz	MHz	MHz	MHz	MHz
42 / 5M	1	0	<b>20.70</b>	20.68	20.46	19.93	19.68	19.88	<b>18.82</b>	18.59	18.63	17.04	16.97	17.00
	1	12	20.61	20.64	20.60	19.81	<b>19.95</b>	19.77	18.38	18.57	18.71	16.74	17.03	16.79
	1	24	20.68	20.59	20.54	19.73	19.73	19.78	18.58	18.69	18.77	<b>17.23</b>	17.10	17.18
	12	0	19.64	19.75	19.93	18.61	18.66	18.60	17.86	17.80	17.83	16.11	16.39	16.23
	12	6	19.86	19.74	19.79	18.82	18.78	18.84	17.73	17.83	17.85	16.33	16.39	16.12
	12	13	19.59	19.49	19.81	18.64	18.66	18.58	17.91	17.49	17.86	16.26	16.42	16.07
	25	0	19.76	19.83	19.78	18.67	18.69	18.71	17.85	17.95	17.88	16.02	15.96	16.13

Band / BW	RB Size	RB Offset	QPSK			16QAM			64QAM			256QAM		
			Low CH	Mid CH	High CH	Low CH	Mid CH	High CH	Low CH	Mid CH	High CH	Low CH	Mid CH	High CH
			43140	43340	43540	43140	43340	43540	43140	43340	43540	43140	43340	43540
			3555	3575	3595	3555	3575	3595	3555	3575	3595	3555	3575	3595
			MHz	MHz	MHz	MHz	MHz	MHz	MHz	MHz	MHz	MHz	MHz	MHz
42 / 10M	1	0	20.12	19.65	19.88	19.04	19.07	19.16	18.06	17.96	17.89	15.92	<b>16.41</b>	16.26
	1	12	20.04	<b>20.24</b>	19.82	19.04	<b>19.44</b>	19.13	18.11	18.10	18.05	16.37	16.18	16.20
	1	24	19.84	19.84	19.89	18.99	19.00	19.26	17.81	18.10	<b>18.17</b>	15.99	15.88	16.05
	12	0	19.04	19.09	18.99	18.06	17.94	18.02	16.77	16.95	17.22	15.44	15.20	15.18
	12	6	18.93	19.10	18.77	18.06	18.18	17.77	17.18	17.09	17.52	15.40	15.49	15.29
	12	13	18.87	19.15	19.46	17.92	18.15	18.06	16.94	17.03	16.92	15.45	15.49	15.31
	25	0	18.80	19.04	18.81	18.11	17.89	18.09	17.18	16.89	16.88	15.21	15.27	15.10

Band / BW	RB Size	RB Offset	QPSK			16QAM			64QAM			256QAM		
			Low CH	Mid CH	High CH	Low CH	Mid CH	High CH	Low CH	Mid CH	High CH	Low CH	Mid CH	High CH
			43165	43340	43515	43165	43340	43515	43165	43340	43515	43165	43340	43515
			3557.5	3575	3592.5	3557.5	3575	3592.5	3557.5	3575	3592.5	3557.5	3575	3592.5
			MHz	MHz	MHz	MHz	MHz	MHz	MHz	MHz	MHz	MHz	MHz	MHz
42 / 15M	1	0	19.71	20.24	20.32	18.91	19.18	19.45	18.38	17.96	18.10	15.90	16.03	<b>16.32</b>
	1	12	20.27	<b>20.39</b>	20.09	19.03	19.45	19.29	18.52	18.02	18.48	16.12	16.07	16.24
	1	24	20.05	19.95	20.11	<b>19.78</b>	19.42	19.61	18.33	<b>18.54</b>	17.93	16.00	15.93	15.96
	12	0	19.03	19.81	19.57	18.88	18.44	18.68	17.30	17.76	17.40	15.60	15.02	15.22
	12	6	19.68	19.43	19.67	19.18	18.88	18.53	17.92	17.61	17.24	15.43	15.41	15.47
	12	13	19.23	19.39	19.23	18.88	18.56	18.74	17.26	17.23	17.32	15.86	15.47	15.37
	25	0	19.79	19.12	19.09	18.55	18.60	18.57	17.63	17.63	17.19	15.33	15.82	15.49

Band / BW	RB Size	RB Offset	QPSK			16QAM			64QAM			256QAM		
			Low CH	Mid CH	High CH	Low CH	Mid CH	High CH	Low CH	Mid CH	High CH	Low CH	Mid CH	High CH
			3560 MHz	3575 MHz	3590 MHz	3560 MHz	3575 MHz	3590 MHz	3560 MHz	3575 MHz	3590 MHz	3560 MHz	3575 MHz	3590 MHz
42 / 20M	1	0	20.66	20.73	20.36	20.20	19.93	19.72	18.32	18.57	18.90	16.43	16.65	16.03
	1	12	21.00	<b>21.08</b>	20.70	20.26	<b>20.45</b>	20.01	18.84	<b>18.94</b>	18.87	16.78	<b>16.80</b>	16.72
	1	24	20.66	20.86	20.53	19.92	19.88	20.37	18.64	18.89	18.74	16.68	16.71	16.11
	12	0	20.10	19.68	19.95	19.52	19.23	19.34	18.24	17.85	17.96	16.15	15.59	15.73
	12	6	20.32	20.03	19.90	19.47	19.36	19.37	18.17	18.36	18.09	16.44	15.71	15.80
	12	13	20.15	19.92	19.88	19.24	19.44	19.51	17.95	18.27	17.73	15.75	15.68	15.69
	25	0	19.73	19.80	19.70	19.12	19.13	19.01	18.23	17.93	17.81	15.85	15.94	15.44

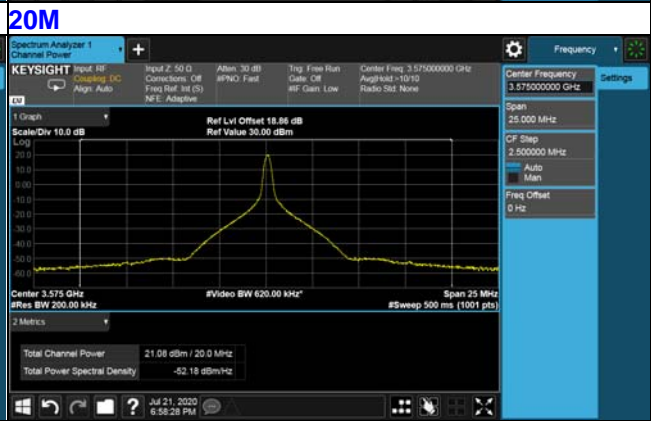
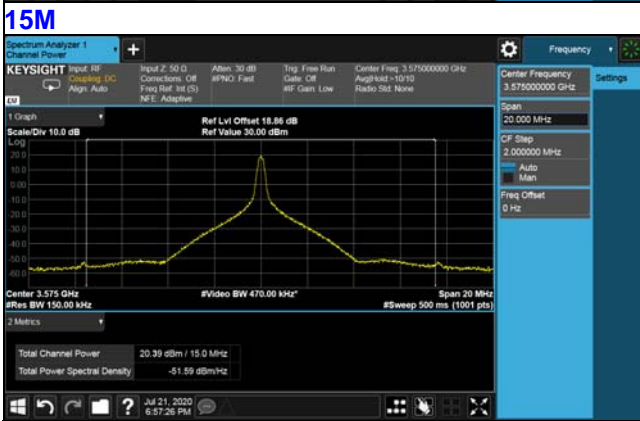
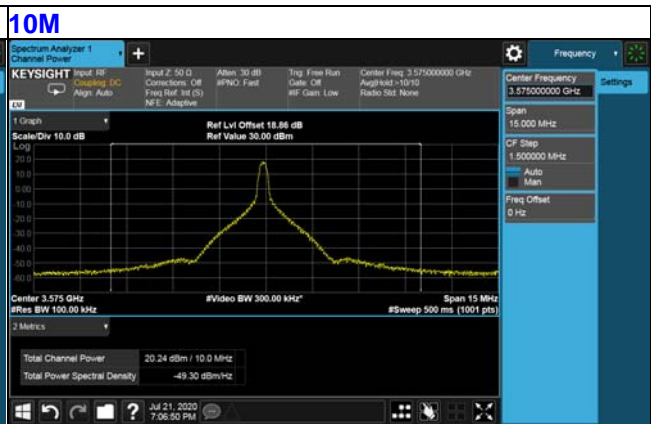
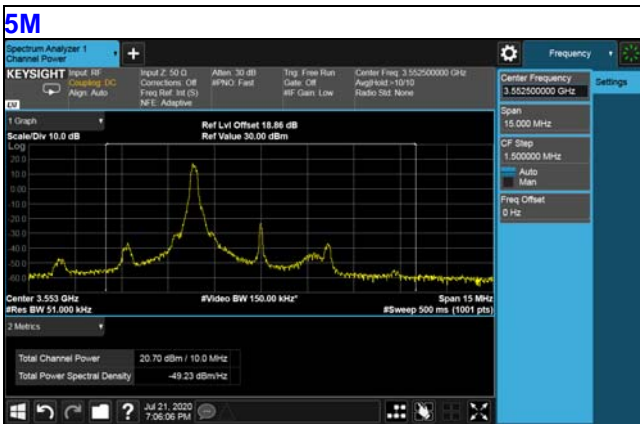

**EIRP Power (dBm) / Full Power**

Band / BW	RB Size	RB Offset	QPSK			16QAM			64QAM			256QAM		
			Low CH	Mid CH	High CH	Low CH	Mid CH	High CH	Low CH	Mid CH	High CH	Low CH	Mid CH	High CH
			43115	43340	43565	43115	43340	43565	43115	43340	43565	43115	43340	43565
			3552.5	3575	3597.5	3552.5	3575	3597.5	3552.5	3575	3597.5	3552.5	3575	3597.5
			MHz	MHz	MHz	MHz	MHz	MHz	MHz	MHz	MHz	MHz	MHz	MHz
42 / 5M	1	0	21.62	21.60	21.38	20.85	20.60	20.80	19.74	19.51	19.55	17.96	17.89	17.92
	1	12	21.53	21.56	21.52	20.73	20.87	20.69	19.30	19.49	19.63	17.66	17.95	17.71
	1	24	21.60	21.51	21.46	20.65	20.65	20.70	19.50	19.61	19.69	18.15	18.02	18.10
	12	0	20.56	20.67	20.85	19.53	19.58	19.52	18.78	18.72	18.75	17.03	17.31	17.15
	12	6	20.78	20.66	20.71	19.74	19.70	19.76	18.65	18.75	18.77	17.25	17.31	17.04
	12	13	20.51	20.41	20.73	19.56	19.58	19.50	18.83	18.41	18.78	17.18	17.34	16.99
	25	0	20.68	20.75	20.70	19.59	19.61	19.63	18.77	18.87	18.80	16.94	16.88	17.05

Band / BW	RB Size	RB Offset	QPSK			16QAM			64QAM			256QAM		
			Low CH	Mid CH	High CH	Low CH	Mid CH	High CH	Low CH	Mid CH	High CH	Low CH	Mid CH	High CH
			43140	43340	43540	43140	43340	43540	43140	43340	43540	43140	43340	43540
			3555	3575	3595	3555	3575	3595	3555	3575	3595	3555	3575	3595
			MHz	MHz	MHz	MHz	MHz	MHz	MHz	MHz	MHz	MHz	MHz	MHz
42 / 10M	1	0	21.04	20.57	20.80	19.96	19.99	20.08	18.98	18.88	18.81	16.84	17.33	17.18
	1	12	20.96	21.16	20.74	19.96	20.36	20.05	19.03	19.02	18.97	17.29	17.10	17.12
	1	24	20.76	20.76	20.81	19.91	19.92	20.18	18.73	19.02	19.09	16.91	16.80	16.97
	12	0	19.96	20.01	19.91	18.98	18.86	18.94	17.69	17.87	18.14	16.36	16.12	16.10
	12	6	19.85	20.02	19.69	18.98	19.10	18.69	18.10	18.01	18.44	16.32	16.41	16.21
	12	13	19.79	20.07	20.38	18.84	19.07	18.98	17.86	17.95	17.84	16.37	16.41	16.23
	25	0	19.72	19.96	19.73	19.03	18.81	19.01	18.10	17.81	17.80	16.13	16.19	16.02

Band / BW	RB Size	RB Offset	QPSK			16QAM			64QAM			256QAM		
			Low CH	Mid CH	High CH	Low CH	Mid CH	High CH	Low CH	Mid CH	High CH	Low CH	Mid CH	High CH
			43165	43340	43515	43165	43340	43515	43165	43340	43515	43165	43340	43515
			3557.5	3575	3592.5	3557.5	3575	3592.5	3557.5	3575	3592.5	3557.5	3575	3592.5
			MHz	MHz	MHz	MHz	MHz	MHz	MHz	MHz	MHz	MHz	MHz	MHz
42 / 15M	1	0	20.63	21.16	21.24	19.83	20.10	20.37	19.30	18.88	19.02	16.82	16.95	17.24
	1	12	21.19	21.31	21.01	19.95	20.37	20.21	19.44	18.94	19.40	17.04	16.99	17.16
	1	24	20.97	20.87	21.03	20.70	20.34	20.53	19.25	19.46	18.85	16.92	16.85	16.88
	12	0	19.95	20.73	20.49	19.80	19.36	19.60	18.22	18.68	18.32	16.52	15.94	16.14
	12	6	20.60	20.35	20.59	20.10	19.80	19.45	18.84	18.53	18.16	16.35	16.33	16.39
	12	13	20.15	20.31	20.15	19.80	19.48	19.66	18.18	18.15	18.24	16.78	16.39	16.29
	25	0	20.71	20.04	20.01	19.47	19.52	19.49	18.55	18.55	18.11	16.25	16.74	16.41

\*EIRP = Conducted + antenna gain(0.92dBi).

Band / BW	RB Size	RB Offset	QPSK			16QAM			64QAM			256QAM		
			Low CH	Mid CH	High CH	Low CH	Mid CH	High CH	Low CH	Mid CH	High CH	Low CH	Mid CH	High CH
			43190	43340	43490	43190	43340	43490	43190	43340	43490	43190	43340	43490
			3560	3575	3590	3560	3575	3590	3560	3575	3590	3560	3575	3590
			MHz	MHz	MHz	MHz	MHz	MHz	MHz	MHz	MHz	MHz	MHz	MHz
42 / 20M	1	0	21.58	21.65	21.28	21.12	20.85	20.64	19.24	19.49	19.82	17.35	17.57	16.95
	1	12	21.92	<b>22.00</b>	21.62	21.18	<b>21.37</b>	20.93	19.76	<b>19.86</b>	19.79	17.70	<b>17.72</b>	17.64
	1	24	21.58	21.78	21.45	20.84	20.80	21.29	19.56	19.81	19.66	17.60	17.63	17.03
	12	0	21.02	20.60	20.87	20.44	20.15	20.26	19.16	18.77	18.88	17.07	16.51	16.65
	12	6	21.24	20.95	20.82	20.39	20.28	20.29	19.09	19.28	19.01	17.36	16.63	16.72
	12	13	21.07	20.84	20.80	20.16	20.36	20.43	18.87	19.19	18.65	16.67	16.60	16.61
	25	0	20.65	20.72	20.62	20.04	20.05	19.93	19.15	18.85	18.73	16.77	16.86	16.36

\*EIRP = Conducted + antenna gain(0.92dBi).



## 4.2 Radiated Emission Measurement

### 4.2.1 Limits of Radiated Emission Measurement

The power of any emissions below 3530 MHz or above 3720 MHz shall not exceed -40dBm/MHz.

### 4.2.2 Test Instruments

Refer to section 4.1.3 to get information of above instrument.

### 4.2.3 Test Procedures

- a. Substitution method is used for EIRP measurement. In the semi-anechoic chamber, EUT placed on the 0.8 meters (for 30MHz ~ 1GHz) / 1.5 meters (for above 1GHz) height of Turn Table, rotated the table around 360 degrees to search the maximum radiation power and receiver antenna shall be rotated vertical and horizontal polarization and moved height from 1m to 4m to find the maximum polar radiated power. The "Read Value" is the spectrum reading the maximum power value.
- b. The substitution antenna is substituted for EUT at the same position and signals generator export the CW signal to the substitution antenna via a TX cable. Rotated the Turn Table and moved receiving antenna to find the maximum radiation power. Adjust output power level of S.G to get a Value of spectrum reading equal to "Read Value" of step a. Record the power level of S.G
- c.  $EIRP = \text{Output power level of S.G} - \text{TX cable loss} + \text{Antenna gain of substitution horn}.$
- d. ERP power can be calculated form EIRP power by subtracting the gain of dipole,  $ERP \text{ power} = EIRP \text{ power} - 2.15dBi.$

**Note:** The resolution bandwidth of spectrum analyzer is 1 MHz and the video bandwidth is 3 MHz.

### 4.2.4 Deviation from Test Standard

No deviation.

#### 4.2.5 Test Set Up

##### <Frequency Range below 1GHz>

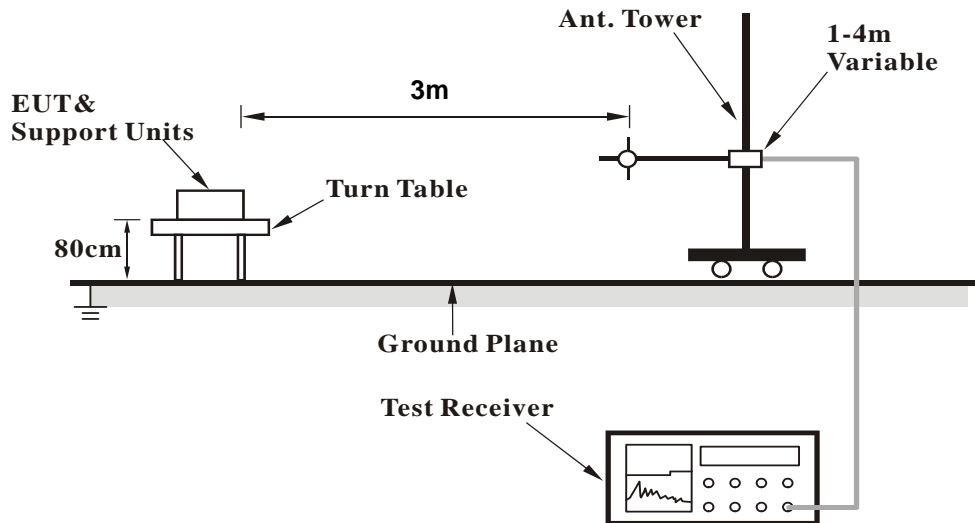

##### <Frequency Range above 1GHz>

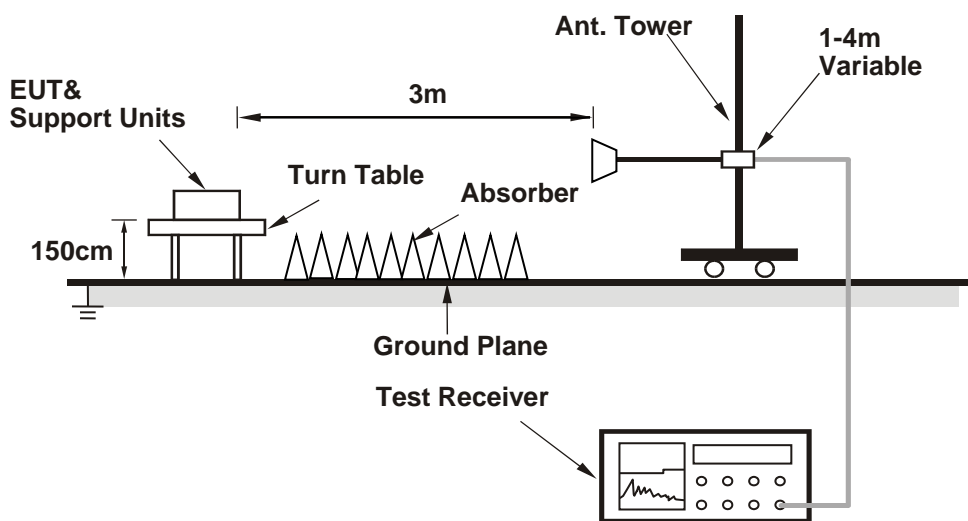

For the actual test configuration, please refer to the attached file (Test Setup Photo).

#### 4.2.6 Test Results

Test was done with 50ohm terminator on antenna port.

Below 1GHz Data :

LTE Band 48

Channel Bandwidth: 20 MHz / QPSK

Mode	TX channel 55990 (3625.0MHz)	Frequency Range	Below 1000 MHz
Environmental Conditions	22deg. C, 66%RH	Input Power	120Vac, 60Hz
Tested By	Greg Lin		

Antenna Polarity & Test Distance: Horizontal at 3 M							
No.	Freq. (MHz)	Reading (dBm)	S.G Power Value (dBm)	Correction Factor (dB)	EIRP (dBm)	Limit (dBm)	Margin (dB)
1	30.00	-46.4	-31.2	-12.2	-43.4	-40.0	-3.4
2	84.83	-36.5	-43.0	-0.3	-43.3	-40.0	-3.3
3	111.54	-40.3	-49.0	0.4	-48.6	-40.0	-8.6
4	139.65	-43.9	-49.4	-0.3	-49.7	-40.0	-9.7
5	198.70	-42.8	-56.2	5.3	-50.9	-40.0	-10.9
6	312.57	-50.2	-59.1	5.1	-54.0	-40.0	-14.0

Remarks:

1. EIRP (dBm) = S.G Value (dBm) + Correction Factor (dB).
2. Correction Factor (dB) = Substitution Antenna Gain (dB) - Cable Loss (dB).

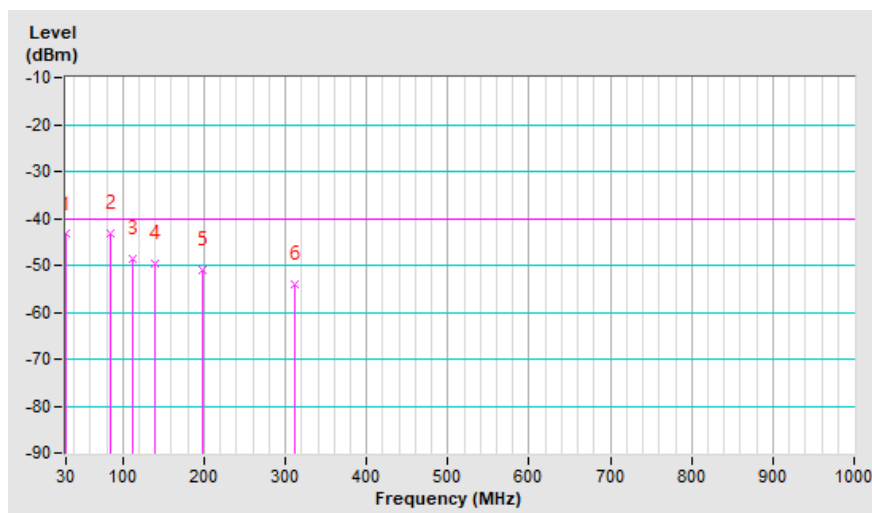

Mode	TX channel 55990 (3625.0MHz)	Frequency Range	Below 1000 MHz
Environmental Conditions	22deg. C, 66%RH	Input Power	120Vac, 60Hz
Tested By	Greg Lin		

Antenna Polarity & Test Distance: Vertical at 3 M							
No.	Freq. (MHz)	Reading (dBm)	S.G Power Value (dBm)	Correction Factor (dB)	EIRP (dBm)	Limit (dBm)	Margin (dB)
1	77.80	-37.6	-40.5	-2.3	-42.8	-40.0	-2.8
2	110.13	-38.0	-46.4	0.4	-46.0	-40.0	-6.0
3	187.45	-46.3	-53.2	3.9	-49.3	-40.0	-9.3
4	290.07	-51.0	-54.9	5.1	-49.8	-40.0	-9.8
5	319.59	-49.6	-54.7	5.2	-49.5	-40.0	-9.5
6	375.83	-61.4	-66.8	5.3	-61.5	-40.0	-21.5

Remarks:

1. EIRP (dBm) = S.G Value (dBm) + Correction Factor (dB).
2. Correction Factor (dB) = Substitution Antenna Gain (dB) - Cable Loss (dB).

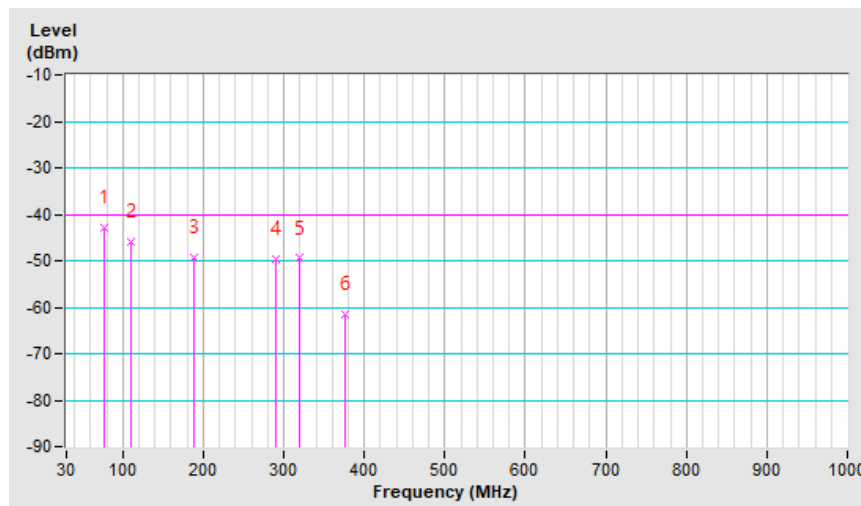

### Above 1GHz

LTE Band 48, Channel Bandwidth 20MHz

Mode	TX channel 55990 (3625.0MHz)	Frequency Range	1GHz ~ 40GHz
Environmental Conditions	22deg. C, 66%RH	Input Power	120Vac, 60Hz
Tested By	Greg Lin		

Antenna Polarity & Test Distance: Horizontal at 3 M							
No.	Freq. (MHz)	Reading (dBm)	S.G Power Value (dBm)	Correction Factor (dB)	EIRP (dBm)	Limit (dBm)	Margin (dB)
1	7250.00	-64.8	-47.0	0.9	-46.1	-40.0	-6.1
Antenna Polarity & Test Distance: Vertical at 3 M							
No.	Freq. (MHz)	Reading (dBm)	S.G Power Value (dBm)	Correction Factor (dB)	EIRP (dBm)	Limit (dBm)	Margin (dB)
1	7250.00	-63.4	-45.5	0.9	-44.6	-40.0	-4.6

Remarks:

1. EIRP (dBm) = S.G Value (dBm) + Correction Factor (dB).
2. Correction Factor (dB) = Substitution Antenna Gain (dB) - Cable Loss (dB).

## 5 Pictures of Test Arrangements

Please refer to the attached file (Test Setup Photo).

## Appendix – Information of the Testing Laboratories

We, Bureau Veritas Consumer Products Services (H.K.) Ltd., Taoyuan Branch, were founded in 1988 to provide our best service in EMC, Radio, Telecom and Safety consultation. Our laboratories are accredited and approved according to ISO/IEC 17025.

If you have any comments, please feel free to contact us at the following:

**Lin Kou EMC/RF Lab**

Tel: 886-2-26052180

Fax: 886-2-26051924

**Hsin Chu EMC/RF Lab/Telecom Lab**

Tel: 886-3-6668565

Fax: 886-3-6668323

**Hwa Ya EMC/RF/Safety Lab**

Tel: 886-3-3183232

Fax: 886-3-3270892

**Email:** [service.adt@tw.bureauveritas.com](mailto:service.adt@tw.bureauveritas.com)

**Web Site:** [www.bureauveritas-adt.com](http://www.bureauveritas-adt.com)

The address and road map of all our labs can be found in our web site also.

--- END ---