

Pluto







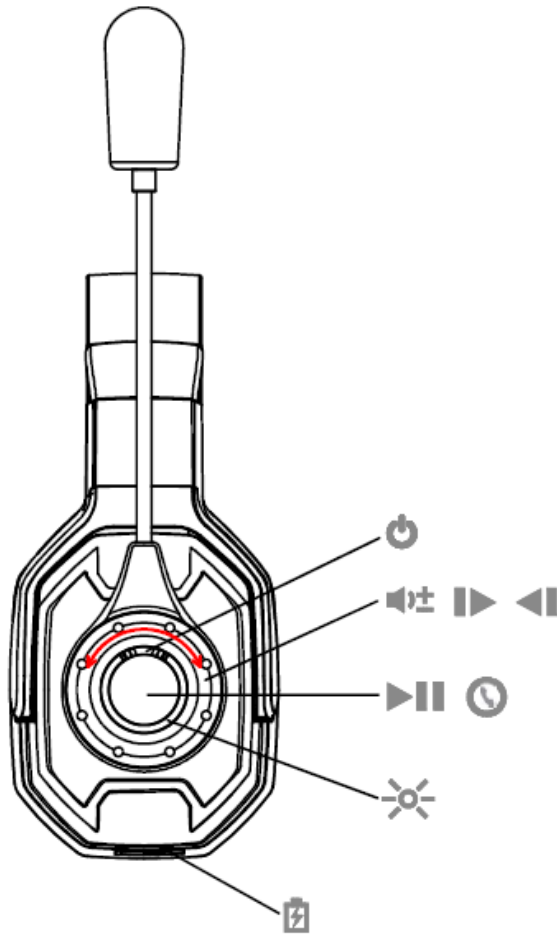

User Guide

FCC ID: 2AQ66SP-001

Model Name: SP-001

Overview



-  Volume up/down
-  Previous track*
-  Play/pause music*
-  [Next track](#)*
-  Charge port
-  Headset LEDs for pairing, battery status [and](#) online indicator
-  Call button ([])
-  Power button

NOTE *Functionality varies by application. Does not function with web-based apps.

Connect and Pair

Pair to mobile device

1. To put your headset in pair mode, press and hold the power button until you hear "pairing" and the headset LEDs flash red and blue.
2. Activate Bluetooth on your phone and set it to search for new devices.
iPhone Settings > Bluetooth > On*
Android Settings > Bluetooth: On > Scan for devices*
NOTE *Menus may vary by device.
3. Select "Pluto."
If necessary, enter four zeros (0000) for the passcode or accept the connection.
Once successfully paired, you will hear "paired" and the headset LEDs stop flashing.

Pairing to a second device

1. To put your headset in pair mode when another device is already paired, press and hold the power button from off until you hear "pairing" and the headset LEDs flash red and blue.
2. Activate Bluetooth on your second device and set it to search for new devices.
iPhone Settings > Bluetooth > On*
Android Settings > Bluetooth: On > Scan for devices*
NOTE *Menus may vary by device.
3. Select "Pluto."
If necessary, enter four zeros (0000) for the passcode or accept the connection.
Once successfully paired, you will hear "paired" and the headset LEDs stop flashing.

Fit and charge

Wear on the right or left

To position the microphone on the right or left side, rotate the microphone boom and over. Adjust the boom so it points to the corner of your mouth.

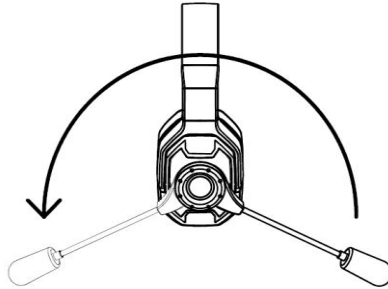

Charge your headset

IMPORTANT *Before using, charge the headset fully to reset the accuracy of the talk time prompts.*

Charge your Pluto with the micro USB cable. The Pluto headset will turn off first and the RED LED light will turn on when charging. It takes up to 3.5 hours to fully charge your headset. The LEDs turn GREEN once charging is complete.

Charge your Pluto with Duo**. Switch the power button to the "ON" position on the Duo** and the RED LED light will turn on when charging. It takes up to 3.5 hours to fully charge your headset. The LEDs turn off once charging is complete.

NOTE *Both the micro USB cable can be plugged into either a computer or car charger.*

****Duo is sold separately. Please visit us at www.stellarelectronic.com for more information**

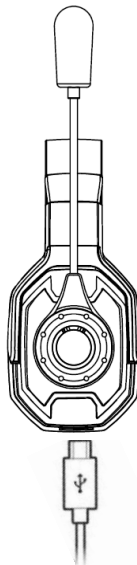

Check headset battery status

Rotate the volume wheel and listen to the voice alert when Pluto is connected (smartphone only).

The basics

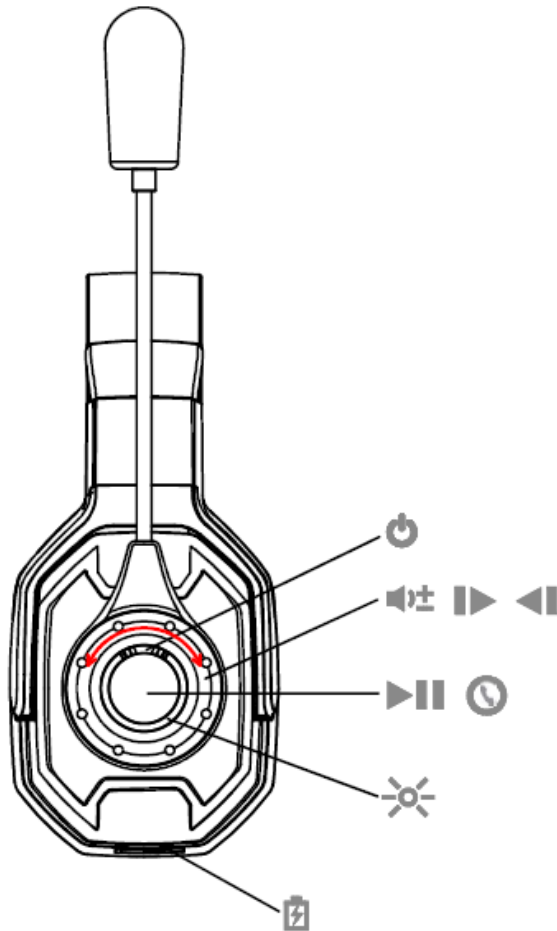



 Volume up/down

 [Previous track](#)*

 Play/pause music*

 [Next track](#)*

 Charge port

 Headset LEDs for pairing, battery status [and](#) online indicator

 Call button ([])

 Power button

NOTE *Functionality varies by application. Does not function with web-based apps.

Make/Take/End Calls

Answer or end a call

Tap the Call  button.

Call back last call (smartphone)

To dial the last number you dialed, double-tap the Call  button.

Voice Control

Connect to Siri and/or Google Assistance

If your smartphone has a voice-enabled assistant, press and hold the Call  button and wait for the phone prompt and then speak the name of the desired contact.

Mute/unmute

While on an active call:

Short press the Power button

Volume



Rotate the volume wheel  forward (+) or backward (-) to control the volume.

Play or pause music

▶|| Short press the Call button

NOTE *Functionality varies by application. Does not function with web-based apps.*

Track selection

Rotate and hold the wheel to the Forward button  or Back button  to control the track selection.

More Features

Conserve battery Mode

If you leave your headphones powered on but out of range of your paired phone or USB adapter for more than 10 minutes, your headset will conserve its battery power by turning off the headphone.

Standby mode



If you leave your headphones powered on and paired to a phone or USB adapter the standby time is about 500 hours, without the Duo.

Answer calls from a second device

It is easy to answer calls from two devices (including softphones)

When on a call, you will hear a ringtone notification of the incoming call from the second paired device.

To answer a second call from the other device and end the current call, tap the Call  button once. If you choose to not answer the second call, it will go to voicemail.

To answer the second call and put the current call on hold, double-tap the Call  button, to switch back to the initial call double-tap the Call  button again.

What's in the box

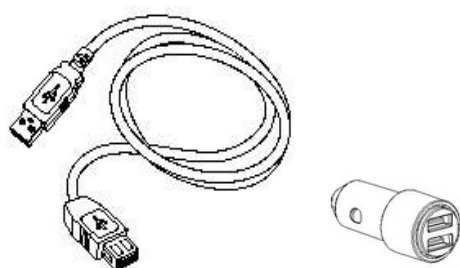

Carrying case, Car charger, Micro USB cable



Connecting Duo** to Pluto device

To connect Duo to Pluto headset, first detach the stabilizer on Pluto and then attach the Duo module. Using StellarConnect technology, the Pluto headset is now in stereo mode.

Switching the power button on Duo will also turn Duo into a power bank to charge the Pluto. The Red LED indicator on Pluto when switched on shows it is being charged.

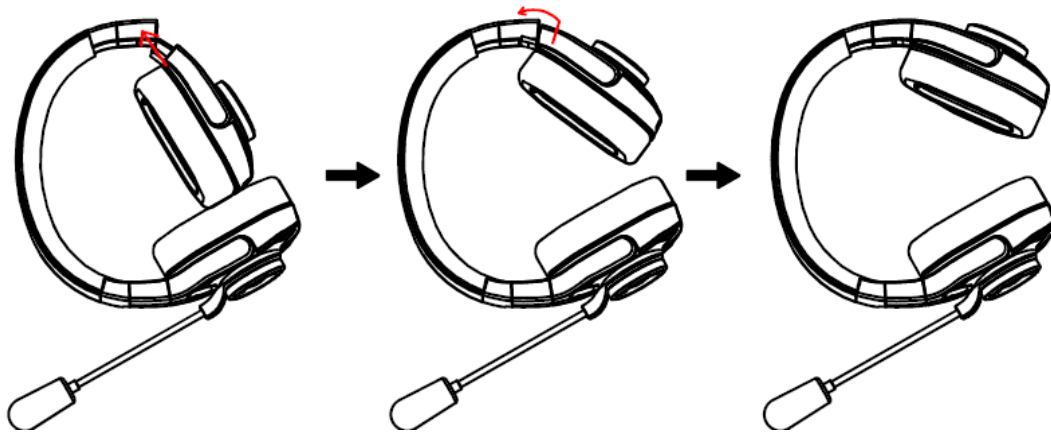

Disconnecting Duo** from Pluto

To disconnect Duo from Pluto, push Duo inward to disconnect. Then, attach the stabilizer back on Pluto.

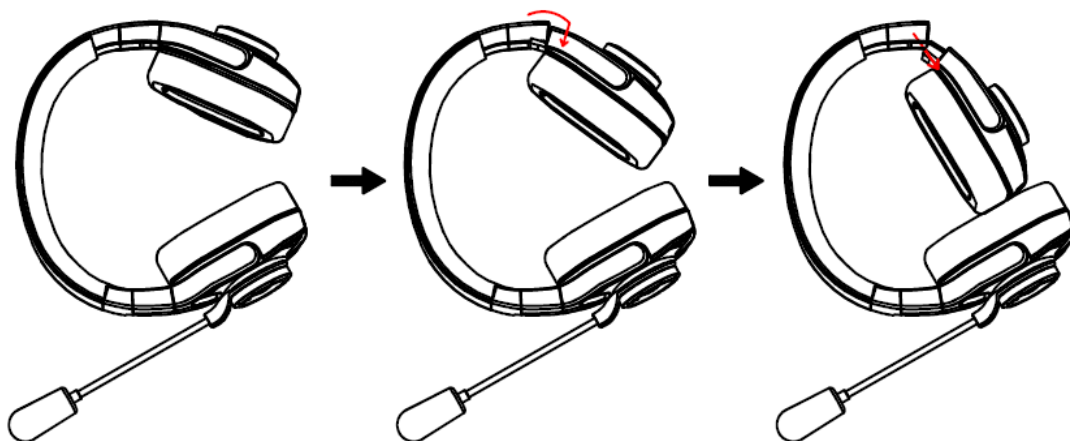

**Duo is sold separately. Please visit us at www.stellarelectronic.com for more information.

Support

For warranty details go to
StellarElectronic.com/support

NEED MORE HELP?
[StellarElectronic.com /support](https://StellarElectronic.com/support)

Stellar Electronic

Email: support@stellarelectronic.com

FCC Warning

This device complies with part 15 of the FCC Rules. Operation is subject to the following two conditions: (1) This device may not cause harmful interference, and (2) this device must accept any interference received, including interference that may cause undesired operation.

Any Changes or modifications not expressly approved by the party responsible for compliance could void the user's authority to operate the equipment.

Note: This equipment has been tested and found to comply with the limits for a Class B digital device, pursuant to part 15 of the FCC Rules. These limits are designed to provide reasonable protection against harmful interference in a residential installation. This equipment generates uses of and can radiate radio frequency energy and, if not installed and used in accordance with the instructions, may cause harmful interference to radio communications. However, there is no guarantee that interference will not occur in a particular installation. If this equipment does cause harmful interference to radio or television reception, which can be determined by turning the equipment off and on, the user is encouraged to try to correct the interference by one or more of the following measures:

- Reorient or relocate the receiving antenna.
- Increase the separation between the equipment and receiver.
- Connect the equipment into an outlet on a circuit different from that to which the receiver is connected.
- Consult the dealer or an experienced radio/TV technician for help.

The device has been evaluated to meet general RF exposure requirement. The device can be used in portable exposure condition without restriction.