

## Belt Drive Turntable System

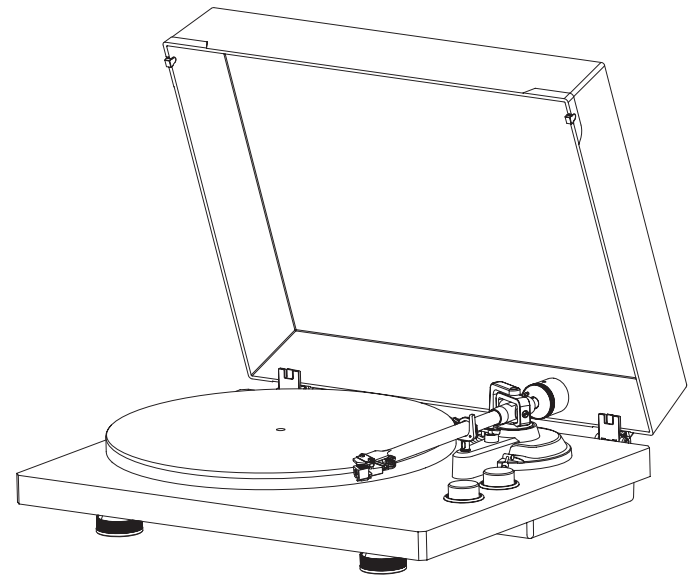

Made in China

Instruction Manual

## Introduction

Thank you for purchasing 1byone Belt Drive Turntable System. This instruction manual contains important information about safety, usage and disposal. Use the product as described and keep this manual for future reference. If you sell this turntable or pass it on, also give this manual to the new owner.

## Important Safety Instructions

1. Read all instructions before use.
2. Keep these instructions for later use.
3. Follow all instructions.
4. Heed all warnings.
5. Do not use this product near water.
6. Clean only with a dry cloth.
7. Do not block any ventilation openings. Install in accordance with the manufacturer.
8. Do not place near any heat sources such as radiators, heat registers, or stoves.
9. Do not defeat the safety purpose of the polarized or grounding-type plug. A polarized plug has two flat prongs with one wider than the other. A grounding type plug has two flat prongs and a third grounding prong. The wide prong or the third prong is provided for your safety. If your outlets are not compatible with this product's power plug, consult an electrician about replacing the obsolete outlets.
10. Protect the power cord from being pinched or walked on, particularly close to the power plug or the point at which the power cord connects to the product.
11. Unplug this product during lightning storms or when unused for long periods of time.
12. Do not overload the electrical outlet. Use only power source as indicated.
13. Only use attachments / accessories specified by the manufacturer.
14. Refer all servicing to qualified service personnel. Servicing is required when the product has been damaged in any way, such as if the power cord is damaged, if liquid has been spilled or objects have fallen onto/into the product, if the product has been exposed to rain or moisture, if the product has been dropped, or if the product has been malfunctioning or not operating normally.
15. This product should not be exposed to dripping or splashing water and objects filled with liquids, such as vases or bowls, should not be placed on the product.
16. Use replacement parts as specified by the manufacturer.
17. Upon completion of any service or repairs to this product, ask the service technician to perform safety checks.

## Product Description

1. Counterweight
2. Anti-skating Stick
3. Turntable Platter
4. Tonearm Lift Lever
5. Tonearm Rest
6. 33/45 RPM Selector
7. Tonearm
8. Stop/Start Dial
9. Cartridge

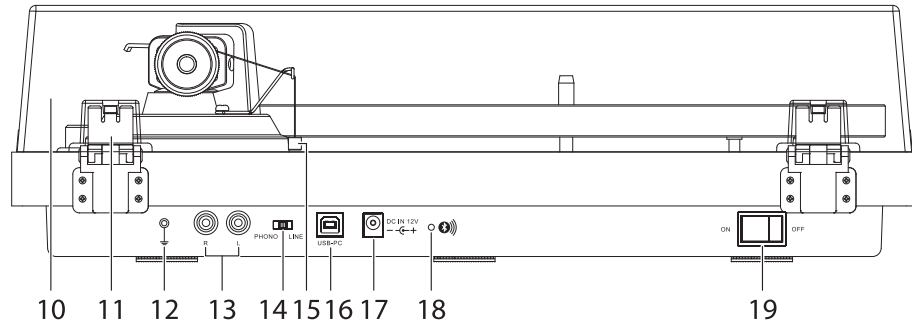
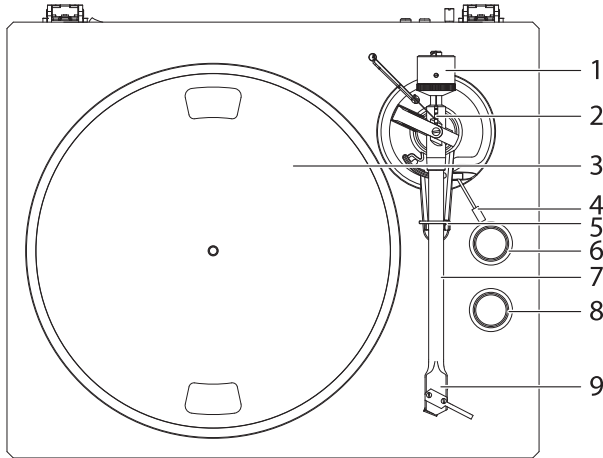

- |                             |                         |
|-----------------------------|-------------------------|
| 10. Lid                     | 15. Anti-skating Weight |
| 11. Lid Hinge               | 16. USB-PC Port         |
| 12. Ground Connector        | 17. AC-DC Power Jack    |
| 13. PHONO & Line Out Jacks  | 18. Bluetooth Indicator |
| 14. PHONO & Line Out Switch | 19. Power Switch        |

Upon opening the turntable's package, locate all of the following included items.

- |                        |                                   |
|------------------------|-----------------------------------|
| 1) Turntable Unit      | 7) 45 RPM Adaptor                 |
| 2) Power Adapter       | 8) Slip Mat                       |
| 3) Lid                 | 9) Cartridge Alignment Protractor |
| 4) Counterweight       | 10) USB-PC Cable                  |
| 5) Anti-skating Weight | 11) Instruction Manual            |
| 6) Platter with Belt   |                                   |

This turntable is supplied with a factory-fitted cartridge that's already adjusted.

Note: Instructions provided in this manual for adjusting the cartridge are provided in case the cartridge is replaced at a later date by a different model.

## Installing the Lid

Install the **Lid** carefully over the hinge prongs.

## Turntable Platter and Belt Setup

1. Set the platter on the spindle.
  - Make sure that the platter is fully seated on the spindle.

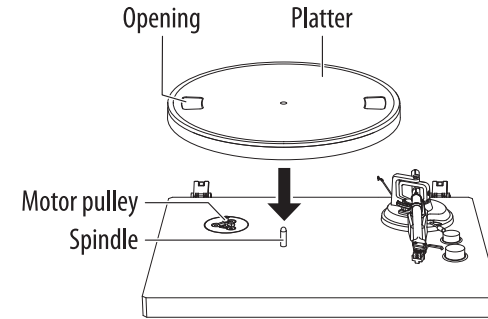

2. Place the belt on the motor pulley.

- Align one of the platter openings with the motor pulley, and, while pulling both ends of the red ribbon that comes attached to the belt, place the belt on the motor pulley, as per the diagram. When doing this, be careful not to twist the belt.

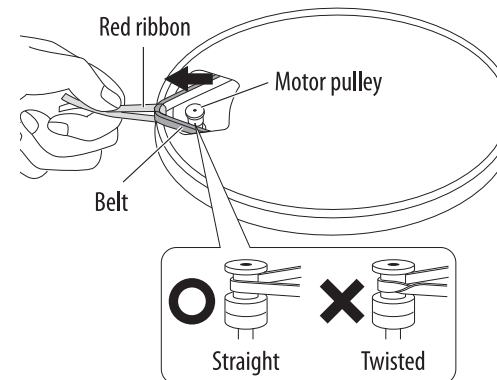

3. Remove the red ribbon from the belt.

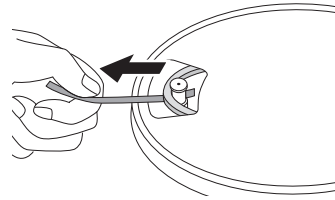

4. Place the slip mat on the platter.

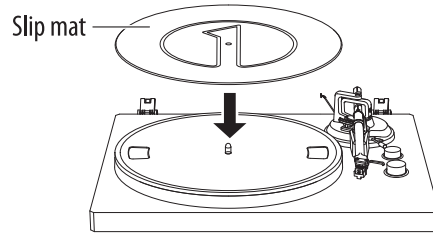

## Cartridge Tracking Force Adjustment

The supplied **Counterweight** is suitable for cartridges weighing between 3.0-6.0g.

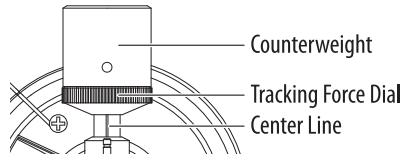

1. Gently push and turn the Counterweight onto the rear of the tonearm (with the dial facing towards the front of the turntable).

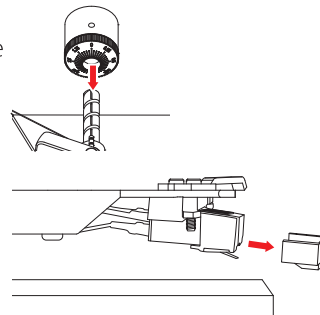

2. Remove the cartridge protection cap.

3. Remove the tie-wrap and unlock the tone arm.

4. Lower the tonearm lift and position the cartridge in the space between the tonearm rest and platter.

5. Carefully rotate the **Counterweight** until the tonearm achieves a neutral, level balance. The tonearm should return to this balanced position if it is moved up or down. Perform this adjustment carefully.

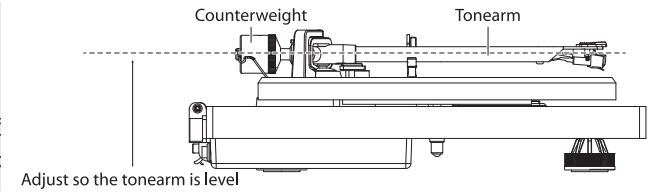
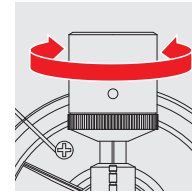

6. Once the tonearm is correctly balanced, return and lock it to the tonearm rest. Next, "Zero" the tonearm by holding the **Counterweight** still and gently rotating only the **tracking force dial** so the "0" is centered over the black line on the top of the **tonearm**. After, unlock the tonearm and check that it still maintains a level balance.

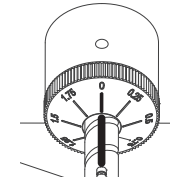
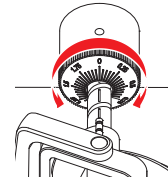

7. Rotate the counterweight counterclockwise (seen from the front) to adjust the tracking force according to the cartridge manufacturer's recommendations.

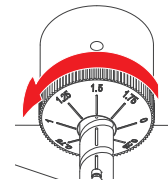

**Note:** Each mark on the dial represents 0.05g. The recommended tracking force for the factory-installed cartridge is  $3.5g \pm 0.5g$ . The cartridge only goes up to 2g for one rotation of the tracking force dial, meaning you will need to make more than one rotation to reach 3.5g.

## Anti-skating Force Adjustment

The anti-skating force must be adjusted corresponding to the tracking force as follows:

Tracking Force	Groove in the stub
5-10 mN	1st from bearing ring
10-15 mN	2nd from the bearing ring
15-20mN	3rd from the bearing ring
20mN and larger	4th from the bearing ring

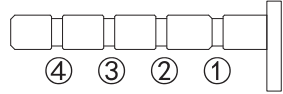

1. Slip the loop of the anti-skating weight's thread over the **3rd** groove of the stick to set the correct anti-skating force for the factory-fitted cartridge.
2. Feed the thread through the hook of the wire support.

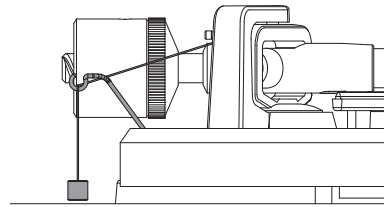
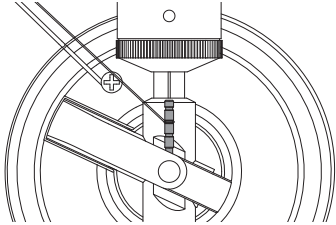

## Setting Phono-Line Out Switch

This product has a built-in phono equalizer function. You can use the turntable, even if you do not have a phono amplifier or connectable equipment with a built-in phono amplifier.

Use the **Phono-Line Out Switch** to set the output, as shown below.

Connectable device being used	Position of Phono-Line Out Switch
Device with phono input	Phono
Device without phono input	Line

## Connection to an Amplifier (Device with Phono input, PHONO mode)

This turntable uses a moving magnetic cartridge. Set the **PHONO & Line Out Switch** on PHONO mode. Connect the phono out cables to the phono input on your amplifier of pre-amplifier (phono stage). **Line inputs such as CD, Tuner, Tape, or Video are not suitable for phono inputs.** Make sure the amplification of the selected input matches the type of cartridge being used. The factory installed cartridge is 47k ohms / MM-input.

**NOTE:** If your amplifier does not have an input suitable for phono cartridges, you will need to purchase a separate phono amplifier for moving magnetic cartridges. This separate phono amplifier will then connect between your turntable and your amplifier.

## Stereo System Connection (Device without phono input, LINE mode)

Set the **PHONO & Line Out Switch** to LINE mode. The RCA **PHONO & Line Out Jacks** output analog line-level signals and can be connected directly with a pair of active/powerful speakers of the appropriate input of your stereo system.

The Red plug connects with the Right channel and the White plug connects with the Left channel.

**NOTE:** The RCA Jacks are not designed to be connected directly to passive/unpowered speakers in LINE mode. If connected to the passive speakers, no sound will come out.

## Main Power Connection

Unpack the power adapter from the foam packing material and plug the small end into the **DC power jack** located on the back of the turntable. Plug the power adapter plug into an electrical outlet.

## Power Management Function

The turntable will automatically go into standby mode after 20 minutes of inactivity. To resume operation, simply press the power switch off, then press it to the "ON" position after 1 second.

## Operation

### Turntable Operation

1. After connecting to power, press the power switch to the "ON" position.
2. Remove the stylus protector from the stylus.
3. Place the slip mat on the platter and place a record on the slip mat. If using 45 RPM records, put the 45 RPM adapter on the center spindle before placing the record on the platter.
4. Set the 33/45 RPM Selector according to the type of record.
5. Turn the Start/Stop dial to the Start position. The platter will start spinning.
6. Unlock the tonearm clip and set the Lift Lever to the up position.



45RPM Adapter

7. Position the tonearm over the desired location (groove) on the record.
8. Move the tonearm lift lever to the down position to move the tonearm toward the record. Alternatively, place the needle over the desired location on the record.
9. Carefully lower the tonearm on the record.
10. When you are finished playing the record, raise the tonearm, return it to rest on the arm clip, and turn the Start/Stop dial to the Stop.

## Bluetooth Operation

This turntable has a Bluetooth transmitter to wirelessly send audio to a Bluetooth speaker.

1. Power on your Bluetooth speaker and ensure it is in pairing mode.
2. Power on the turntable. BT will auto search when the turntable turns on and the BT LED indicator light will flash.
3. When pairing, the light will flash twice per second and will become solid when paired successfully.
4. To disconnect pairing, power off the turntable or turn off Bluetooth pairing on your Bluetooth speaker.
5. This turntable will connect to the nearest Bluetooth speaker. If after 2 minutes no Bluetooth speaker can be found to pair with, the Bluetooth transmitter will become inactive and the LED will turn off. If you need to connect again, power off the turntable and the speaker then power on again.

Bluetooth Indicator	Bluetooth Status
Flash	Auto searching and pairing
Solid	Paired successfully
Off	Inactive

## Recording onto a PC through USB Jack:

For installing and recording instructions, refer to the BRIEF INTRODUCTION OF AUDACITY webpage at <https://www.audacityteam.org/download/>

Recording the vinyl to your computer:

- 1). Follow the instructions in this manual to play the vinyl.
- 2). Open Audacity on your computer and follow the recording steps as instructed on the Audacity webpage referenced above.

## Audacity and USB Connection

Audacity supports Windows95 / Window XP / Window 7 / Vista or more advanced version, with the EMS memory more than 128MB and Audacity take space of 5MB.

## Instructions for PC Encoding After Recording Software instructions

1. Connect the USB cable to your turntable and your computer. No extra drivers are required.

### 2. Recording

#### 2.1) Open Audacity



#### 2.2) Open the "Edit" menu, then choose "Preferences"

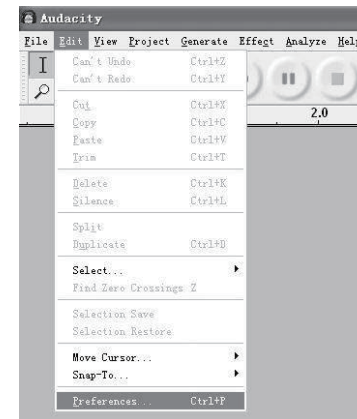

2.3) Set your preferences as desired

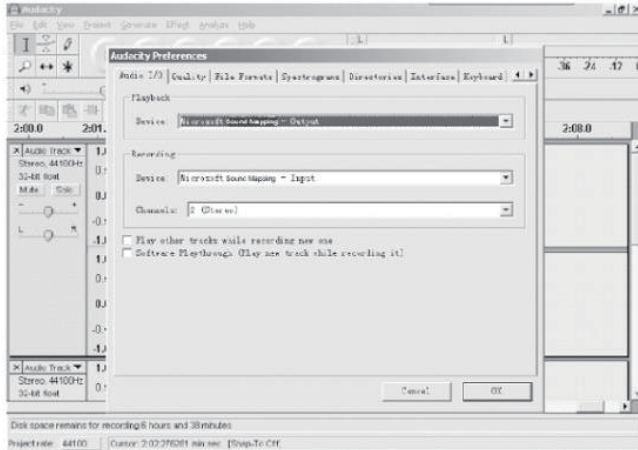

**Note:** Check your computer's audio properties and make sure "SSS USB Audio Device" is selected as shown below:



2.4) Adjust the output and input volume

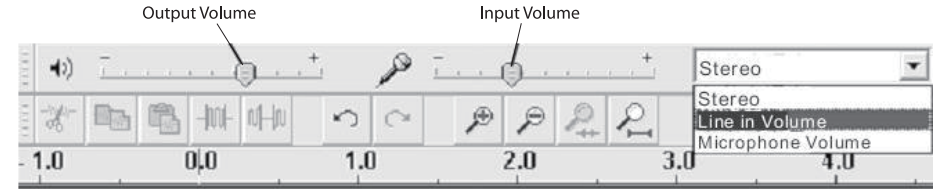

2.5) Press the Record button ● and the left and right tracks will appear on the interface

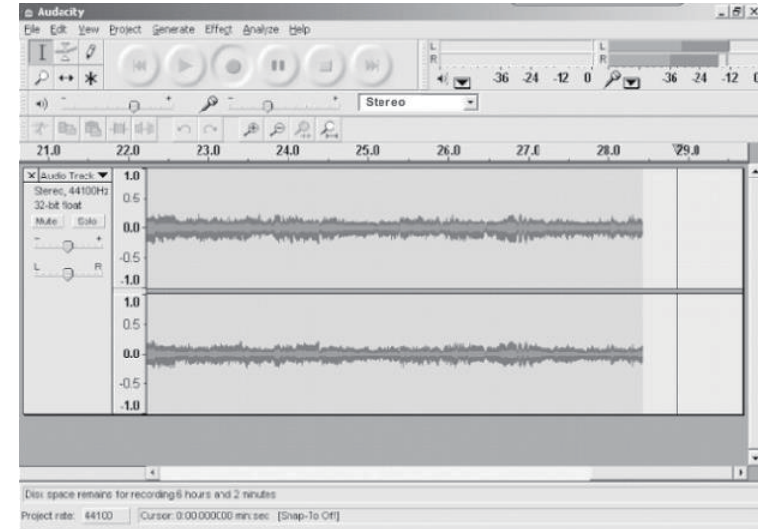

**Note:** If you do not see the sound wave on the interface when recording, please adjust the line in volume to an appropriate level.

- 2.5.1 ⑤ Press the ● button to start recording;
- 2.5.2 ⑥ Press the ◀◀ button to skip to start;
- 2.5.3 ⑦ Press the ▶▶ button to skip to end;
- 2.5.4 ⑧ Press the ▶ button to play;
- 2.5.5 ⑨ Press the || button to pause recording;
- 2.5.6 ⑩ Press the ■ button to stop recording.

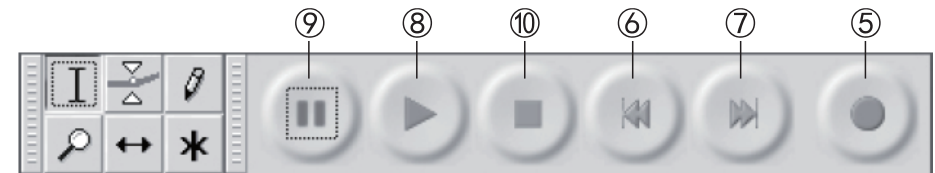



### 3. Export the Music Files to Your Preferred Format

- Once you have finished recording, you should save your music to the computer.
- Open the “File” menu and choose “Export” to export to WAV, MP3 or Ogg formats. WAV format, MP3 format or Ogg format.
- Choose a file format and write a file name to save the music recording.

**Note:** Audacity does not export MP3 files directly; you should download the LAME MP3 encoder. A link to find LAME MP3 can be found at

<https://www.audacityteam.org/download/>

### Instructions for Installing LAME MP3 Encoder

- 1) Download “lame\_enc.dll” file, and install it to the software list.
- 2) Open Audacity, click the Main Menu, select “Edit”, then “Parameter, then “File Formats”, and finally click “Searcher.”

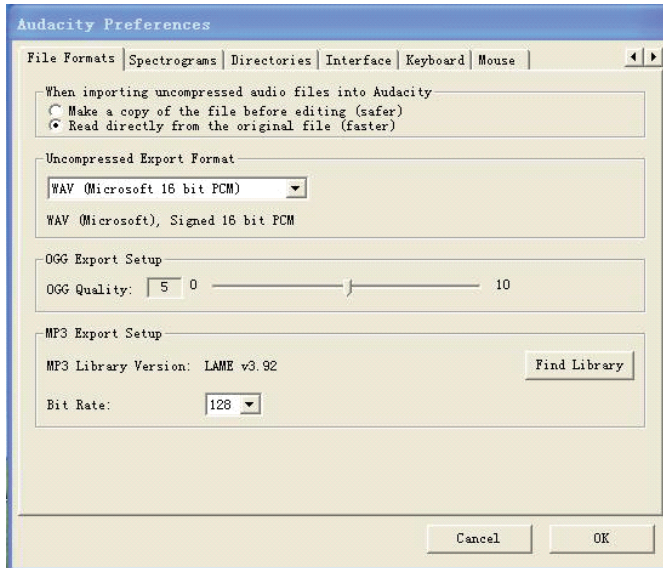

- 3) After opened, it will come to the following menu, click “YES” to go to “Lame\_enc.dll”, and find the file’s location.

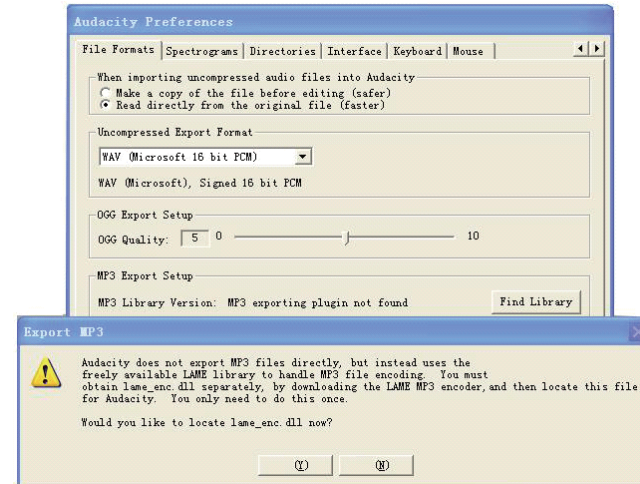

- 4) After finding the “lame\_enc.dll” file, open it and click “Y” to finish installation.

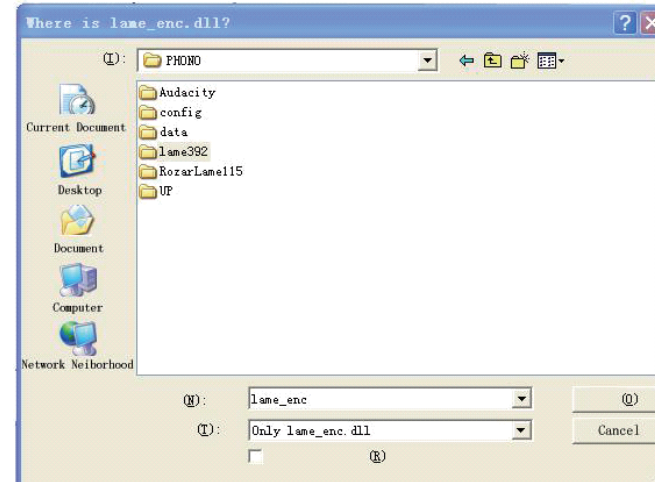



## Maintenance and Cleaning

**NOTE:** Disconnect the power cable plug from the outlet as a precaution before maintenance.

### Turntable Body

Your turntable requires little or no regular maintenance. Remove dust with a slightly damp antistatic cloth; never use a dry cloth as this will create static electricity and attract more dust! Antistatic cleaning agents are available at specialist stores, but must be applied sparingly to avoid damage to rubber parts. It is recommended to install the needle cover before cleaning or maintenance is carried out to avoid damage.

If the turntable is not used over a long period of time, the drive belt should be removed to prevent unequal stretching.

**NOTE:** Always disconnect the record player from the power supply as a precaution before maintenance!

### Useful Tips

The turntable should be positioned on a low-resonance surface such as wood or multiple layer ply board to avoid structural vibrations disturbing playback.

### Stylus Tip

- If dirt and grime are stuck to the stylus tip, clean it with a commercially-sold brush.
- We recommend using a stylus cleaner (not included) if the stylus tip is considerably dirty. Clean the stylus tip by moving the brush from the rear to the front of the stylus tip.

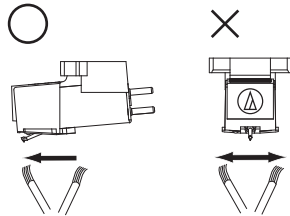

## Replacing the Stylus

### Removing the Stylus

- In addition to the deterioration of sound quality, records may also be damaged as the cartridge's stylus tip wears down.
- As a rule of thumb, replace the stylus after 300 to 500 hours of use.
- Be sure to disconnect the product's power cable plug from the outlet.

1. Remove the protector from the cartridge.

2. Remove the stylus by pulling in the direction of the arrow.

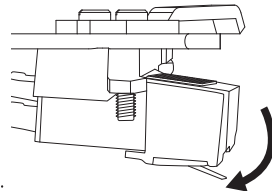

## Installing a New Replacement Stylus

1. Grasp both sides of the stylus holder and insert the stylus grip into the rear tab of the cartridge.

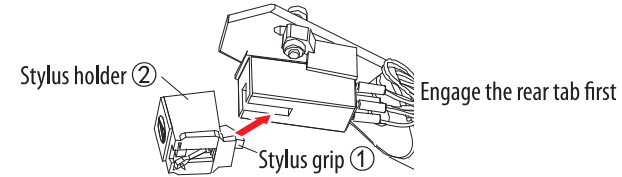

2. Push up the stylus holder until it clicks and locks completely in place.

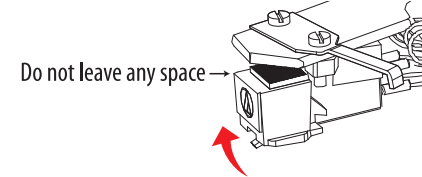

## Cartridge Replacement

1. Before replacement, put the stylus protector back on the stylus to prevent damage to the stylus during the replacement process.
2. Carefully remove the wire leads from the original cartridge.
3. Loosen the two screws on the headshell that are securing the cartridge and then remove the original cartridge.
4. Mount the new cartridge to the headshell and tighten it lightly. Do not completely tighten the screws at this moment.
5. Connect the wire leads to the new cartridge's terminals. The wire lead color codes are as below:

Wire	Channel
White	Left channel positive (L+)
Black	Left channel negative (L-)
Red	Right channel positive (R+)
Black	Right channel negative (R-)

6. Adjust the cartridge's position to make sure it is precisely aligned on the headshell so that the stylus will be tracking the grooves in parallel perfectly.

To achieve this, place the included paper **cartridge alignment protractor** over the turntable spindle, carefully lift the tone arm and place the tip of the stylus on the points marked 130mm and 250mm respectively. Fine tune the cartridge's position on the headshell until the cartridge is perfectly in parallel with the reference lines at both points.

7. Tighten the screws completely once the perfect alignment is achieved.

**NOTE:** If you are unfamiliar or uncomfortable with completing this procedure, we recommend consulting with a professional to perform the installation.

## Technical Specifications

### Turntable

Model	1-AD07US01,H005	Speed Variance	±1.5%
Nominal Speeds	33 1/3 & 45RPM	Wow and Flutter	≤0.15%
Effective Tonearm Length	8.6" (218.5mm)	Signal to Noise	55dB
Tracking Force Range	3.0-6.0g	Overhang	0.73in
Outboard Power Supply	12V/ 500mA AC-DC	Power Consumption	5W
AC Power Adapter	Input: 100-240V 50/60Hz, Max. 200mA		
Dimensions (W x H x D)	16.34" x 10.2" x 4.44" (415 x 340 x 148mm)		
Weight	13.67lbs (6.2kg)		

### Cartridge

Stylus Model	Audio Technica AT-3600L
Frequency Response	20Hz-20kHz
Recommended Load Resistance	47kohms
Channel Balance	< 2.5dB
Amplifier Connection	MM - input
Channel Separation	> 18dB
Recommended Tracking Force	3.5±0.5g
Output Voltage	2.5mV
Weight	5g

## Potential Incorrect Use and Fault Conditions

This turntable is manufactured to the highest standards and undergoes strict quality controls before leaving the factory. Faults that may possibly occur are not necessarily due to material or production faults but can sometimes be caused by incorrect use or unfortunate circumstances. Therefore the following list of common fault symptoms has been included here.

### There is no power:

- The turntable is not connected to the power adapter.
- No power at the outlet.

### The platter doesn't turn although the unit is switched on:

- The unit is not connected to the main power supply.
- No power at the outlet.
- Drive belt is not installed or has slipped off.

### No signal through one or both channels:

- Phono input not selected on amplifier.
- Amplifier not switched on.
- Amplifier or speakers muted.
- No connection to the speakers.
- No connection between turntable and amplifier.
- Wire leads not connected the cartridge.

### Strong hum on phono input:

- No ground connection from cartridge, arm, or arm cable to amplifier or ground loop.
- Turntable is too close to speakers.

### Distorted or inconsistent sound from one or both channels:

- Turntable is connected to wrong input of the amplifier.
- Needle or cantilever damaged.
- Drive belt overstretched or dirty.
- Platter bearing without oil, dirty or damaged.
- Dust on stylus.
- MM / MC switch on pre-amplifier set incorrectly.

### Cannot connect with Bluetooth speaker:

- The turntable is not in pairing mode.
- Your Bluetooth speaker is not in pairing mode.
- The Bluetooth transmitter has turned off because Bluetooth is not connected in 2 minutes.

**Needle isn't touching the record:**

- The screw on the tonearm rest may have loosened during transport. Gently turn this screw clockwise to move the needle stylus closer to the record.

**Needle is scratching the record's surface:**

- Gently turn the tonearm rest screw anticlockwise to move the needle stylus away from the turntable.

**NOTE:** Factory screw tightness is based on the thickness of the included slip mat. If a thinner or thicker 3rd-party slip mat is used, gently adjust the screw as needed following the steps in the last two situations.



This product's packaging is made from environmentally friendly material and can be disposed of at your local recycling plant.

## FCC Warnings

This device complies with part 15 of the FCC Rules. Operation is subject to the following two conditions: (1) This device may not cause harmful interference, and (2) this device must accept any interference received, including interference that may cause undesired operation.

Any Changes or modifications not expressly approved by the party responsible for compliance could void the user's authority to operate the equipment.

Note: This equipment has been tested and found to comply with the limits for a Class B digital device, pursuant to part 15 of the FCC Rules. These limits are designed to provide reasonable protection against harmful interference in a residential installation. This equipment generates uses and can radiate radio frequency energy and, if not installed and used in accordance with the instructions, may cause harmful interference to radio communications. However, there is no guarantee that interference will not occur in a particular installation. If this equipment does cause harmful interference to radio or television reception, which can be determined by turning the equipment off and on, the user is encouraged to try to correct the interference by one or more of the following measures:

- Reorient or relocate the receiving antenna.
- Increase the separation between the equipment and receiver.
- Connect the equipment into an outlet on a circuit different from that to which the receiver is connected.
- Consult the dealer or an experienced radio/TV technician for help.

The device has been evaluated to meet general RF exposure requirement. The device can be used in portable exposure condition without restriction.