

FCC 47 CFR PART 15 SUBPART C

TEST REPORT

For

Product Name: Indoor Air Quality Monitor

Brand Name: OurAir

Model No.: SPB308

Series Model: N.A.

FCC ID: 2AQ3Q-SPB308

Test Report Number:
C181214R01-RPW

Issued for

MANN HUMMEL (China) Co., Ltd.

No.168 Xingqing Road Jiading Industrial Zone, 201815 Shanghai, China

Issued by

Compliance Certification Services Inc.

Kun shan Laboratory

No.10 Weiye Rd., Innovation park, Eco&Tec,
Development Zone, Kunshan City, Jiangsu, China

TEL: 86-512-57355888

FAX: 86-512-57370818



Note: This report shall not be reproduced except in full, without the written approval of Compliance Certification Services Inc. This document may be altered or revised by Compliance Certification Services Inc. personnel only, and shall be noted in the revision section of the document. The client should not use it to claim product endorsement by A2LA or any government agencies. The test results in the report only apply to the tested sample.

TABLE OF CONTENTS

1.	TEST RESULT CERTIFICATION	4
2.	EUT DESCRIPTION	5
3.	SUMMARY OF THE TEST RESULT	6
4.	TEST METHODOLOGY	7
4.1.	EUT CONFIGURATION	7
4.2.	EUT EXERCISE	7
4.3.	GENERAL TEST PROCEDURES	7
4.4.	FCC PART 15.205 RESTRICTED BANDS OF OPERATIONS	8
4.5.	DESCRIPTION OF TEST MODES	9
4.6.	ANTENNA DESCRIPTION	10
5.	INSTRUMENT CALIBRATION	11
5.1.	MEASURING INSTRUMENT CALIBRATION	11
5.2.	MEASUREMENT UNCERTAINTY	13
6.	FACILITIES AND ACCREDITATIONS	14
6.1.	FACILITIES	14
6.2.	EQUIPMENT	14
6.3.	LABORATORY ACCREDITATIONS AND LISTING	14
6.4.	TABLE OF ACCREDITATIONS AND LISTINGS	15
7.	SETUP OF EQUIPMENT UNDER TEST	17
7.1.	SETUP CONFIGURATION OF EUT	17
7.2.	SUPPORT EQUIPMENT	17
7.	FCC PART 15.247 REQUIREMENTS	18
7.1.	6DB BANDWIDTH	18
7.2.	PEAK POWER	24
7.3.	PEAK POWER SPECTRAL DENSITY	26
7.4.	SPURIOUS EMISSIONS	33
7.5.	RADIATED EMISSIONS	51
7.6.	POWERLINE CONDUCTED EMISSIONS	73

Revision History

Rev.	Issue Date	Report NO.	Effect Page	Contents
00	November 20, 2018	C180918R02-RPW	ALL	N/A
Update	December 14, 2018	C181214R01-RPW	P1,P4	Update name of applicant.
01	January 15, 2019	C181214R01-RPW	P5,P12,P62-P63	Revise antenna gain; Update data of radiated emissions below 1G.

1. TEST RESULT CERTIFICATION

Product Name:	Indoor Air Quality Monitor
Trade Name:	OurAir
Model Name.:	SPB308
Series Model:	N.A.
Applicant Discrepancy:	Initial
Device Category:	mobile unit
Date of Test:	October 15, 2018 ~ November 19, 2018
Applicant:	MANN HUMMEL (China) Co., Ltd. No.168 Xingqing Road Jiading Industrial Zone, 201815 Shanghai, China
Manufacturer:	ShangHai Digital Intelligent Technology CO.,Ltd. Floor 17, 1313 Jiangchang Rd Jingan District, Shanghai, China
Application Type:	Certification

APPLICABLE STANDARDS	
STANDARD	TEST RESULT
FCC 47 CFR Part 15 Subpart C	No non-compliance noted

We hereby certify that:

The above equipment was tested by Compliance Certification Services Inc. The test data, data evaluation, test procedures, and equipment configurations shown in this report were made in accordance with the procedures given in ANSI C63.10: 2013 and the energy emitted by the sample EUT tested as described in this report is in compliance with the requirements of FCC Rules Part 15.207, 15.209, 15.247.

The test results of this report relate only to the tested sample EUT identified in this report.

Approved by:

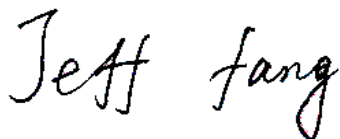

Jeff.Fang
 RF Manager
 Compliance Certification Service Inc.

Reviewed by:

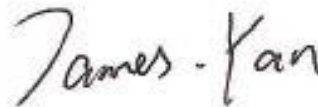

James.Yan
 RF Section Manager
 Compliance Certification Service Inc.

2. EUT DESCRIPTION

Product Name:	Indoor Air Quality Monitor
Brand Name:	OurAir
Model Name:	SPB308
Series Model:	N.A.
Model Discrepancy:	N/A
Power Rating:	MODEL:A241-2401000U INPUT: 100~240 ~ 50/60Hz 0.8A OUTPUT: 24V --- 1000mA
Frequency Range:	IEEE 802.11b/g: 2412MHz to 2462 MHz IEEE 802.11n HT20: 2412MHz to 2462 MHz
Max Peak Output Power:	IEEE 802.11b mode: 18.36dBm IEEE 802.11g mode: 21.44dBm IEEE 802.11n HT20 mode: 22.19dBm
Max Average Output Power:	IEEE 802.11b mode: 15.32dBm IEEE 802.11g mode: 10.81dBm IEEE 802.11n HT20 mode: 11.99dBm
Modulation Technique:	IEEE802.11b mode: DSSS (1,2,5.5 and 11 Mbps) IEEE802.11g mode: DSSS /OFDM (6,9,12,18,24,36,48 and 54 Mbps) IEEE802.11n HT20 mode: OFDM (MCS0~MCS7)
Number of Channels:	IEEE 802.11b/g mode: 11 Channels IEEE 802.11n HT20: 11 Channels
Antenna Specification:	PCB antenna Gain: 1.82 dBi

Remark:

- 1.The sample selected for test was engineering sample that approximated to production product and was provided by manufacturer.
- 2.This submittal(s) (test report) is intended for **FCC ID: 2AQ3Q-SPB308** filing to comply with Section 15.207, 15.209 and 15.247 of the FCC Part 15, Subpart C Rules.

3. SUMMARY OF THE TEST RESULT

FCC 47 CFR Part 15, Subpart C 15.247			
Part	Rule section	Description of Test	Result
7.1	47 CFR Part 15, Subpart C 15.247	6db Bandwidth	Complies
7.2	47 CFR Part 15, Subpart C 15.247	Peak Power	Complies
7.3	47 CFR Part 15, Subpart C 15.247	Peak Power Spectral Density	Complies
7.4	47 CFR Part 15, Subpart C 15.247	Spurious Emissions	Complies
7.5	47 CFR Part 15, Subpart C 15.247	Radiated Emissions	Complies
7.6	47 CFR Part 15, Subpart C 15.247	Powerline Conducted Emissions	Complies

4. TEST METHODOLOGY

The tests documented in this report were performed in accordance with ANSI C63.10 2013 and FCC CFR 47 15.207, 15.209, 15.247 and KDB 558074.

4.1.EUT CONFIGURATION

The EUT configuration for testing is installed on RF field strength measurement to meet the Commissions requirement and operating in a manner that intends to maximize its emission characteristics in a continuous normal application.

4.2.EUT EXERCISE

The EUT was operated in the engineering mode to fix the TX frequency that was for the purpose of the measurements.

According to its specifications, the EUT must comply with the requirements of the Section 15.207, 15.209 and 15.247 under the FCC Rules Part 15 Subpart C.

4.3.GENERAL TEST PROCEDURES

Conducted Emissions

The EUT is placed on the turntable, which is 0.8 m above ground plane. According to the requirements in Section 6.2 of ANSI C63.10 2013 Conducted emissions from the EUT measured in the frequency range between 0.15 MHz and 30MHz using CISPR Quasi-peak and average detector modes.

Radiated Emissions

Under 1GHz

The EUT is placed on a turn table, which is 0.8 m above ground plane. The turntable shall rotate 360 degrees to determine the position of maximum emission level. EUT is set 3m away from the receiving antenna, which varied from 1m to 4m to find out the highest emission. And also, each emission was to be maximized by changing the polarization of receiving antenna both horizontal and vertical. In order to find out the maximum emissions, exploratory radiated emission measurements were made according to the requirements in Section 6.4 & 6.5 of ANSI C63.10:2013.

Above 1GHz

The EUT is placed on a turn table, which is 1.5 m above ground plane. The turntable shall rotate 360 degrees to determine the position of maximum emission level. EUT is set 3m away from the receiving antenna, which varied from 1m to 4m to find out the highest emission. And also, each emission was to be maximized by changing the polarization of receiving antenna both horizontal and vertical. In order to find out the maximum emissions, exploratory radiated emission measurements were made according to the requirements in Section 6.6 of ANSI C63.10:2013.

4.4.FCC PART 15.205 RESTRICTED BANDS OF OPERATIONS

Except as shown in paragraph (d) of this section, only spurious emissions are permitted in any of the frequency bands listed below:

MHz	MHz	MHz	GHz
0.090 - 0.110	16.42 - 16.423	399.9 - 410	4.5 - 5.15
¹ 0.495 - 0.505	16.69475 - 16.69525	608 - 614	5.35 - 5.46
2.1735 - 2.1905	16.80425 - 16.80475	960 - 1240	7.25 - 7.75
4.125 - 4.128	25.5 - 25.67	1300 - 1427	8.025 - 8.5
4.17725 - 4.17775	37.5 - 38.25	1435 - 1626.5	9.0 - 9.2
4.20725 - 4.20775	73 - 74.6	1645.5 - 1646.5	9.3 - 9.5
6.215 - 6.218	74.8 - 75.2	1660 - 1710	10.6 - 12.7
6.26775 - 6.26825	108 - 121.94	1718.8 - 1722.2	13.25 - 13.4
6.31175 - 6.31225	123 - 138	2200 - 2300	14.47 - 14.5
8.291 - 8.294	149.9 - 150.05	2310 - 2390	15.35 - 16.2
8.362 - 8.366	156.52475 - 156.52525	2483.5 - 2500	17.7 - 21.4
8.37625 - 8.38675	156.7 - 156.9	2655 - 2900	22.01 - 23.12
8.41425 - 8.41475	162.0125 - 167.17	3260 - 3267	23.6 - 24.0
12.29 - 12.293	167.72 - 173.2	3332 - 3339	31.2 - 31.8
12.51975 - 12.52025	240 - 285	3345.8 - 3358	36.43 - 36.5
12.57675 - 12.57725	322 - 335.4	3600 - 4400	(²)
13.36 - 13.41			

¹ Until February 1, 1999, this restricted band shall be 0.490-0.510 MHz.

² Above 38.6

Except as provided in paragraphs (d) and (e), the field strength of emissions appearing within these frequency bands shall not exceed the limits shown in Section 15.209. At frequencies equal to or less than 1000 MHz, compliance with the limits in Section 15.209 shall be demonstrated using measurement instrumentation employing a CISPR quasi-peak detector. Above 1000 MHz, compliance with the emission limits in Section 15.209 shall be demonstrated based on the average value of the measured emissions. The provisions in Section 15.35 apply to these measurements.

4.5.DESCRPTION OF TEST MODES

The worst-case data rates:

IEEE802.11b mode:

Channel Low (2412MHz)

Channel Mid (2437MHz)

Channel High (2462MHz) with 1Mbps data rate was chosen for full testing.

IEEE802.11g mode:

Channel Low (2412MHz)

Channel Mid (2437MHz)

Channel High (2462MHz) with 6Mbps data rate was chosen for full testing.

IEEE 802.11n HT20 MHz Channel mode:

Channel Low (2412MHz)

Channel Mid (2437MHz)

Channel High (2462MHz) with MCS0 data rate was chosen for full testing.

4.6.ANTENNA DESCRIPTION

According to FCC 47 CFR 15.203

“an intentional radiator antenna shall be designed to ensure that no antenna other than that furnished by the responsible party can be used with the device. The use of a permanently attached or an antenna that uses a unique coupling to the intentional radiator shall be considered sufficient to comply with the provisions of this section”

As the photo below, the EUT use a unique coupling to the intentional radiator attached antenna, so the EUT complies with the requirement of 15.203.

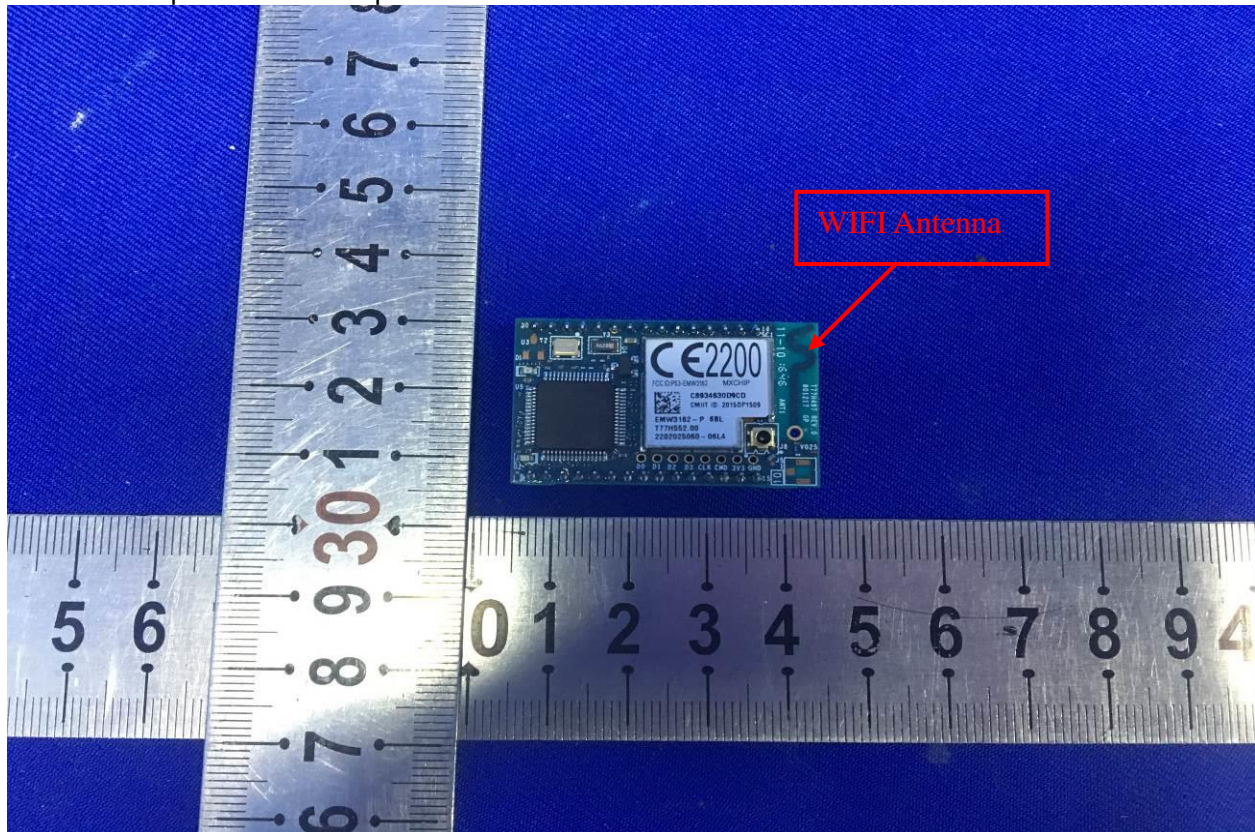

5. INSTRUMENT CALIBRATION

5.1. MEASURING INSTRUMENT CALIBRATION

The measuring equipment, which was utilized in performing the tests documented herein, has been calibrated in accordance with the manufacturer's recommendations for utilizing calibration equipment, which is traceable to recognized national standards.

Equipment Used for Emissions Measurement

Conducted Emissions Test Site					
Name of Equipment	Manufacturer	Model	Serial Number	Calibration Data	Calibration Due
Signal Analyzer	R&S	FSV40	101493	2017-12-18	2018-12-17
Spectrum Analyzer	RS	FSU26	200789	2018-7-13	2019-7-12
Power meter	Anritsu	ML2495A	1445010	2018-4-26	2019-4-25
Power sensor	Anritsu	MA2411B	1339220	2018-4-26	2019-4-25
Power SPLITTER	Mini-Circuits	ZN2PD-9G	SF078500430	N.C.R	N.C.R
DC Power Supply	AGILENT	E3632A	MY50340053	N.C.R	N.C.R
Cable	N/A	Cable-05	N/A	2018-4-24	2019-4-23
Cable	N/A	Cable-06	N/A	2018-4-24	2019-4-23
6dB Attenuator	N/A	N/A	N/A	2018-4-24	2019-4-23
Temp. / Humidity Gauge	Anymetre	TH603	CCS007	2018-10-30	2019-10-29
Test Software			EZ-EMC ver.3A1		

Conducted Emission					
Name of Equipment	Manufacturer	Model	Serial Number	Calibration Date	Calibration Due
EMI TEST RECEIVER	R&S	ESCI	100781	2018-2-26	2019-2-25
V (V-LISN)	SCHWARZBECK	NNLK 8129	8129-143	2018-10-28	2019-10-27
TWO-LINE V-NETWORK	R&S	ENV216	101604	2018-10-28	2019-10-27
Pulse LIMITER	R&S	ESH3-Z2	100524	2017-12-27	2018-12-26
Cable	Thermax	Cable-02	14	2017-12-27	2018-12-26
Test Software			EZ-EMC ver.3A1		

977 Chamber					
Name of Equipment	Manufacturer	Model	Serial Number	Calibration Data	Calibration Due
Spectrum Analyzer	RS	FSU26	200789	2018-7-13	2019-7-12
Spectrum Analyzer	RS	FSV40	101493	2017-12-18	2018-12-17
EMI Test Receiver	R&S	ESCI	101378	2017-12-26	2018-12-25
EMI Test Receiver	R&S	ESCI	101378	2018-12-21	2019-12-20
Amplifier	COM-POWER	PAM-840A	461332	2017-11-29	2018-11-28
Amplifier	COM-POWER	PAM-118A	551044	2018-4-26	2019-4-25
Broad-Band Horn Antenna	SCHWARZBECK	BBHA 9170	9170-515	2018-2-27	2019-2-26
Bilog Antenna	SCHAFFNER	CBL6112D	36996	2018-7-7	2019-7-6
Loop Antenna	COM-POWER	AL-130R	10160008	2018-5-8	2019-5-7
Horn-antenna	SCHWARZBECK	9120D	D:266	2018-2-26	2019-2-25
Turn Table	CT	CT123	4165	N.C.R	N.C.R
Antenna Tower	CT	CTERG23	3256	N.C.R	N.C.R
Controller	CT	CT100	95637	N.C.R	N.C.R
Cable	REBES MICROWAVE	Cable-93	N/A	2018-10-28	2019-10-27
Cable	REBES MICROWAVE	Cable-94	N/A	2018-10-28	2019-10-27
Cable	REBES MICROWAVE	Cable-95	N/A	2018-10-28	2019-10-27
Cable	N/A	Cable-03	N/A	2018-4-24	2019-4-23
Cable	N/A	Cable-04	N/A	2018-4-24	2019-4-23
2.4G Filter	N/A	N/A	N/A	2018-4-24	2019-4-23
Test Software			EZ-EMC ver.3A1		

Remark: Each piece of equipment is scheduled for calibration once a year.

5.2.MEASUREMENT UNCERTAINTY

For the test methods, according to the present document, the measurement uncertainty figures shall be calculated in accordance with TR 100 028-1 [2] and shall correspond to an expansion factor (coverage factor) $k = 1,96$ or $k = 2$ (which provide confidence levels of respectively 95 % and 95,45 % in the case where the distributions characterizing the actual measurement uncertainties are normal (Gaussian)).

Table 6 is based on such expansion factors.

Table 6: Maximum measurement uncertainty

Parameter	Uncertainty
RF output power, conducted	$\pm 1.129\text{dB}$
Unwanted Emissions, conducted	$\pm 2.406\text{dB}$
RF Power density, conducted	$\pm 2.379\text{dB}$
Conducted emissions	$\pm 2.582\text{dB}$
All emissions, radiated (Below 1GHz)	$\pm 4.725\text{dB}$
All emissions, radiated (Above 1GHz)	$\pm 4.818\text{dB}$
Temperature	$\pm 0.3\text{dB}$
Supply voltages	$\pm 0.2\%$

6. FACILITIES AND ACCREDITATIONS

6.1. FACILITIES

All measurement facilities used to collect the measurement data are located at CCS China Kunshan Lab at 10#Weiye Rd, Innovation Park Eco. & Tec. Development Zone Kunshan city JiangSu, (215300), CHINA.

The sites are constructed in conformance with the requirements of ANSI C63.7, ANSI C63.10 2013 and CISPR Publication 22.

6.2. EQUIPMENT

Radiated emissions are measured with one or more of the following types of linearly polarized antennas: tuned dipole, biconical, log periodic, bi-log, and/or ridged waveguide, horn. Spectrum analyzers with pre-selectors and quasi-peak detectors are used to perform radiated measurements.

Conducted emissions are measured with Line Impedance Stabilization Networks and EMI Test Receivers.

Calibrated wideband preamplifiers, coaxial cables, and coaxial attenuators are also used for making measurements.

All receiving equipment conforms to CISPR Publication 16-1, "Radio Interference Measuring Apparatus and Measurement Methods."

6.3. LABORATORY ACCREDITATIONS AND LISTING

FCC –Designation Number: CN1172.

Compliance Certification Services Inc. Kunshan Laboratory has been registered and fully described in a report filed with the (FCC) Federal Communications Commission. The acceptance letter from the FCC is maintained in our files and the Designation Number: CN1172.

6.4. TABLE OF ACCREDITATIONS AND LISTINGS

Country	Agency	Scope of Accreditation	Logo
USA	A2LA	<p>47 CFR FCC, Part 15, Subpart B (using ANSI 63.4 :2009 and ANSI C63.4:2014); ICES-003; 47 CFR FCC, Part 18 (using MP-5:1986); ICES-001; VCCI - V3; VCCI-CISPR-32 (up to 6GHz); VCCI 32-1; CNS 13438 (up to 6GHz); CNS 13439; CNS 13803; CISPR 11; EN 55011; CISPR 13; EN 55013; CISPR 22; EN 55022; AS/NZS CISPR 22; CISPR32; EN55032; AS/NZS CISPR 32; EN55014-1 (excluding clicks); CISPR 14-1 (excluding clicks); EN55015; CISPR 15;</p> <p>IEC 61000-3-2; EN 61000-3-2; AS/NZS 61000.3.2 IEC 61000-3-3; EN 61000-3-3; AS/NZS 61000.3.3 IEC 61000-4-2; EN 61000-4-2; AS/NZS 61000.4.2 IEC 61000-4-3; EN 61000-4-3; AS/NZS 61000.4.3 IEC 61000-4-4; EN 61000-4-4; AS/NZS 61000.4.4 IEC 61000-4-5; EN 61000-4-5; AS/NZS 61000.4.5 IEC 61000-4-6; EN 61000-4-6; AS/NZS 61000.4.6 IEC 61000-4-8; EN 61000-4-8; AS/NZS 61000.4.8 IEC 61000-4-11; EN 61000-4-11; AS/NZS 61000.4.11 EN 61000-6-1; EN 61000-6-2; EN 61000-6-3 (excluding discontinuous interference); EN 61000-6-4; IEC 61000-6-1; IEC 61000-6-2; IEC 61000-6-3 (excluding discontinuous interference); IEC 61000-6-4; AS/NZS 61000.6.1; AS/NZS 61000.6.2; AS/NZS 61000.6.3 (excluding discontinuous interference); AS/NZS 61000.6.4;</p> <p>EN 55024; CISPR 24; AS/NZS CISPR 24; EN 61547; IEC 61547; EN 60601-1-2; IEC 60601-1-2; EN 50130-4; EN 55014-2; CISPR 14-2; EN 62040-2; IEC 62040-2; EN 61204-3; IEC 61204-3; EN 50121-1; EN 50121-3-2; EN 50121-4; EN 50121-5; EN 50155 (clauses 5.4 and 5.5); EN 61326-1; IEC 61326-1; EN 50083-2; EN 300 386; EN 301 489-1 (excluding Section 9.6); EN 301 489-3; EN 301 489-7; EN 301 489-17; EN 301 489-19; EN 301 489-24; EN 301 489-25; EN 301 489-34 FCC Part 15, Subparts 15C, 15E (KDB 905462 D03 (v01r02))(using ANSI C63.4:2009, ANSI C63.4:2014 and ANSI C63.10:2013) FCC Parts 22E, 24E (using ANSI/TIA-603-D) RSS-132; RSS-133; RSS-210; RSS-247 (excluding DFS testing) EN 300 220-1; EN 300 220-2; EN 300 328; EN 300 330-1; EN 300 330-2; EN 300 440-1; EN 300 440-2; EN 301 893 (excluding DFS testing); EN 301 511 (clauses 4.2.12 to 4.2.19, and 5.2.12 to 5.2.19); EN 301 908-1 (clauses 4.2.2, 4.2.3, 5.3.1, and 5.3.2);</p>	

		EN 301 908-2 (clauses 4.2.4, 4.2.10, 5.3.3, and 5.3.9) AS/NZS 4268 IEEE Std 1528:2013; EN 50360; EN 50566; EN 62479; EN 50383; EN 50385; EN 62311; IEC 62209-1; EN 62209-1; IEC 62209-2; EN 62209-2; CNS 14958-1; CNS 14959; RSS-102; ACMA Radio Communications (Electromagnetic Radiation – Human Exposure) Standard 2014	
USA	FCC	3/10 meter Sites to perform FCC Part 15/18 measurements	 CN1172
Japan	VCCI	3/10 meter Sites and conducted test sites to perform radiated/conducted measurements	VCCI R-1600 C-1707 G-216

** No part of this report may be used to claim or imply product endorsement by A2LA or any agency of the US Government.*

7. SETUP OF EQUIPMENT UNDER TEST

7.1.SETUP CONFIGURATION OF EUT

See test photographs attached in Setup photo for the actual connections between EUT and support equipment.

7.2.SUPPORT EQUIPMENT

No.	Device Type	Brand	Model	Series No.	FCC ID
1.	Notebook	acer	ZQT	N/A	N/A

Remark:

1. All the equipment/cables were placed in the worst-case configuration to maximize the emission during the test.
2. Grounding was established in accordance with the manufacturer's requirements and conditions for the intended use.

7. FCC PART 15.247 REQUIREMENTS

7.1.6DB BANDWIDTH

LIMIT

According to §15.247(a)(2), systems using digital modulation techniques may operate in the 902 - 928 MHz, and 2400 - 2483.5 MHz bands, and 5725 - 5850 MHz bands. The minimum 6dB bandwidth shall be at least 500kHz.

Test Configuration

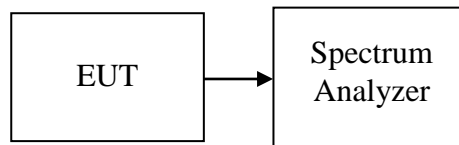

TEST PROCEDURE

Set the spectrum analyzer as RBW = 100 kHz, VBW = 300 kHz, Sweep = auto couple.

TEST RESULTS

No non-compliance noted

Test Data

IEEE 802.11b mode

Channel	Frequency (MHz)	Bandwidth (MHz)	Limit (kHz)	Result
Low	2412	8.567	>500	PASS
Mid	2437	8.517		PASS
High	2462	9.030		PASS

IEEE 802.11g mode

Channel	Frequency (MHz)	Bandwidth (MHz)	Limit (kHz)	Result
Low	2412	16.382	>500	PASS
Mid	2437	16.382		PASS
High	2462	16.382		PASS

IEEE 802.11n HT20 mode

Channel	Frequency (MHz)	Bandwidth (MHz)	Limit (kHz)	Result
Low	2412	17.656	>500	PASS
Mid	2437	17.663		PASS
High	2462	17.598		PASS

Test Plot IEEE 802.11b MODE 6dB Bandwidth (CH Low)

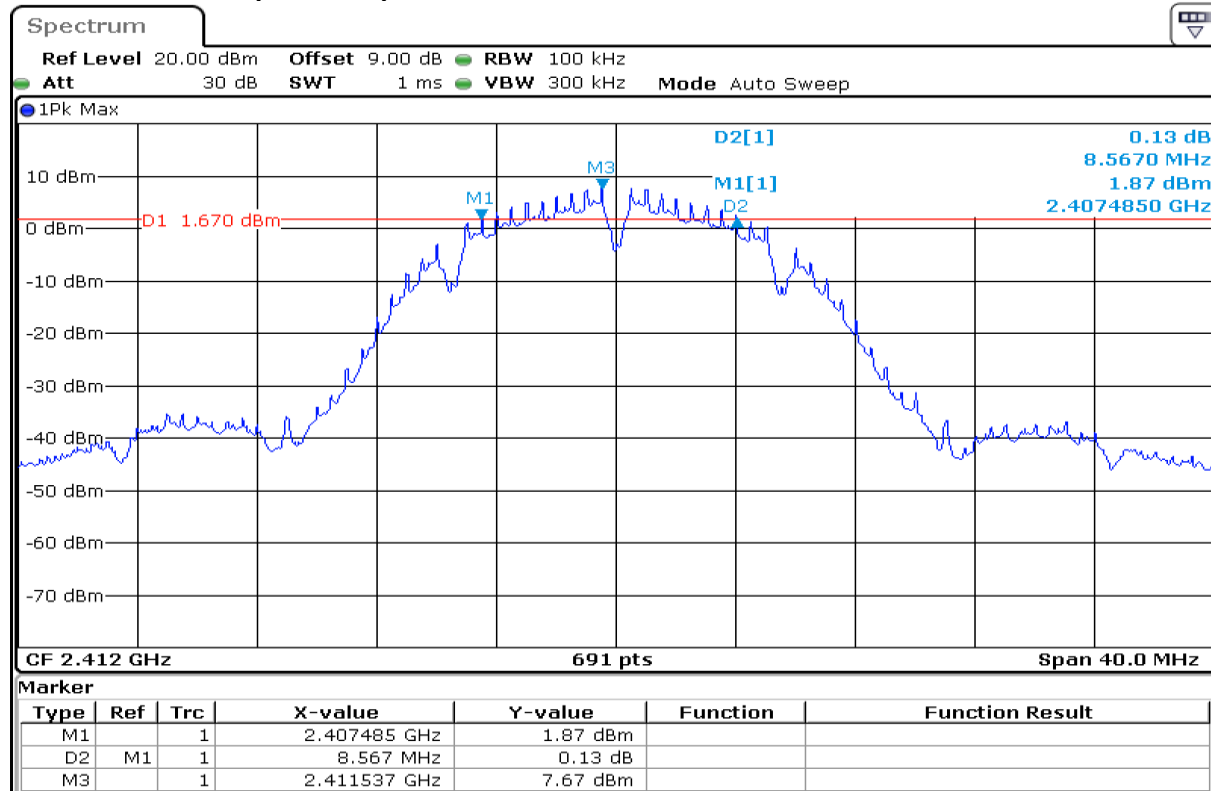

6dB Bandwidth (CH Mid)

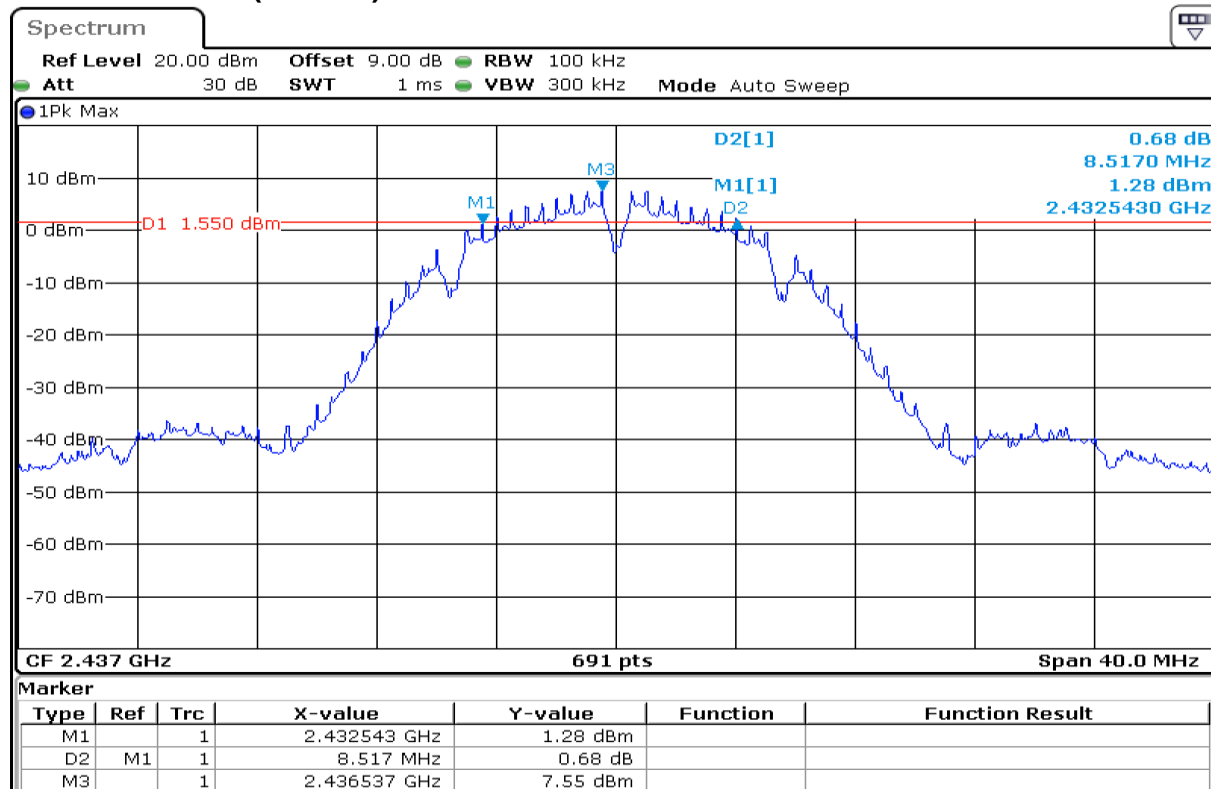

6dB Bandwidth (CH High)

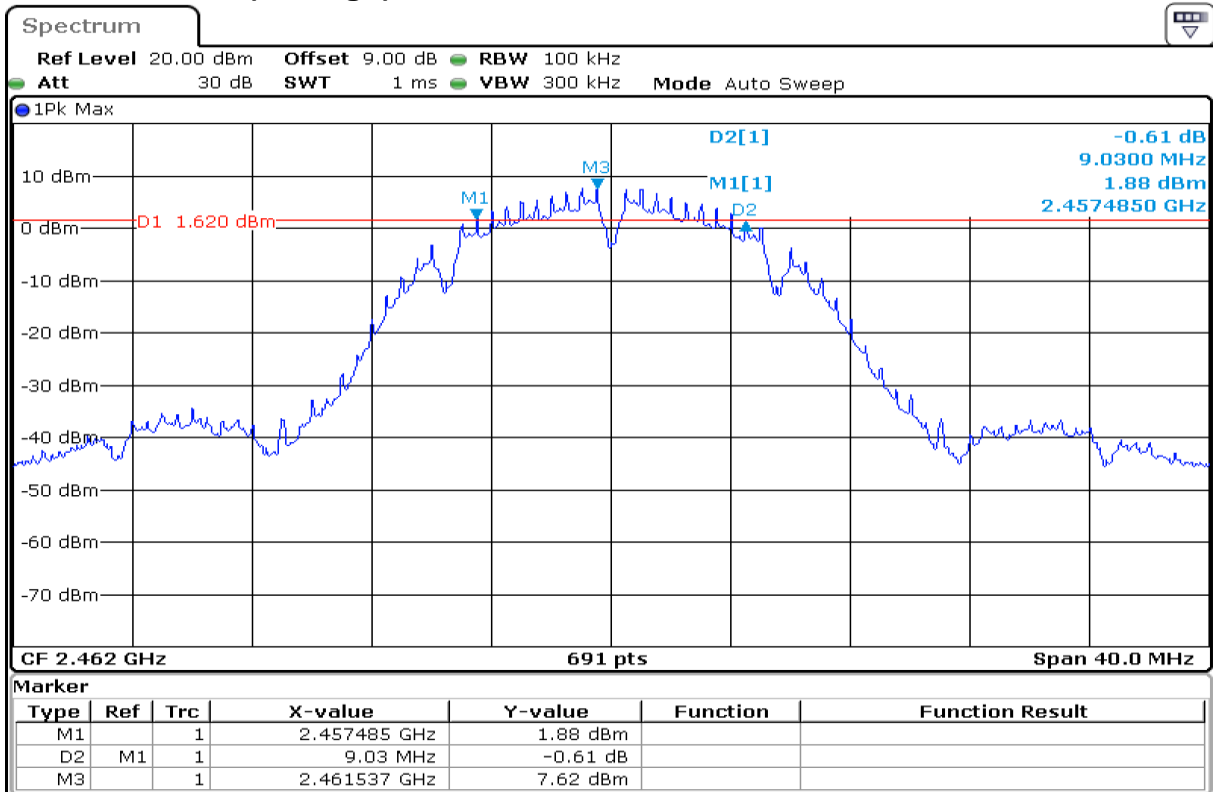

IEEE 802.11g MODE

6dB Bandwidth (CH Low)

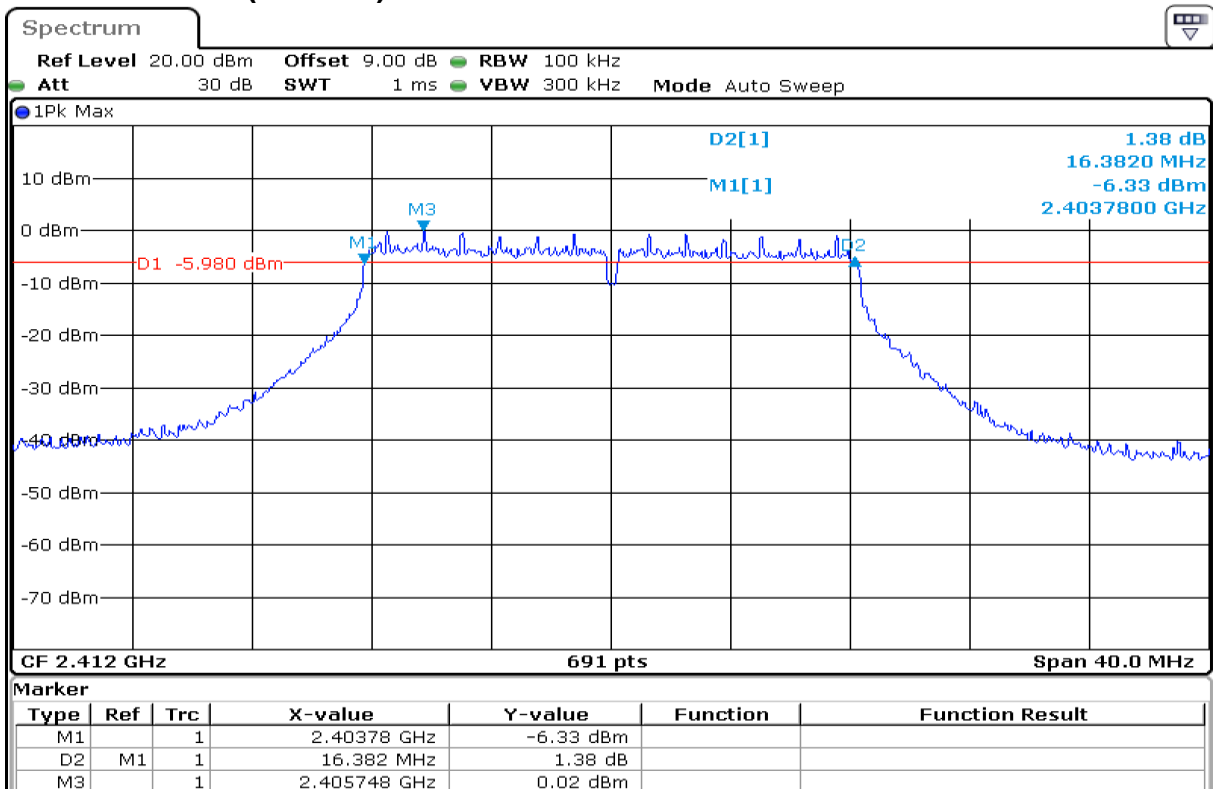

6dB Bandwidth (CH Mid)

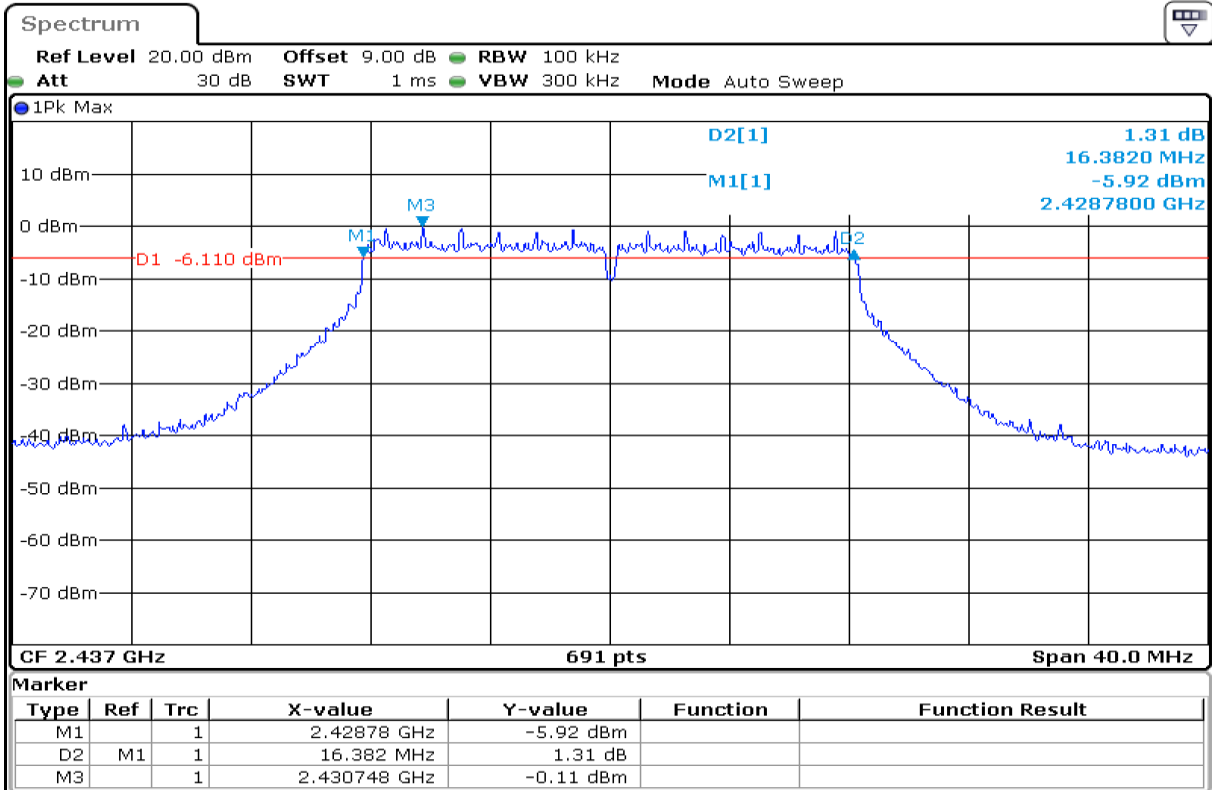

6dB Bandwidth (CH High)

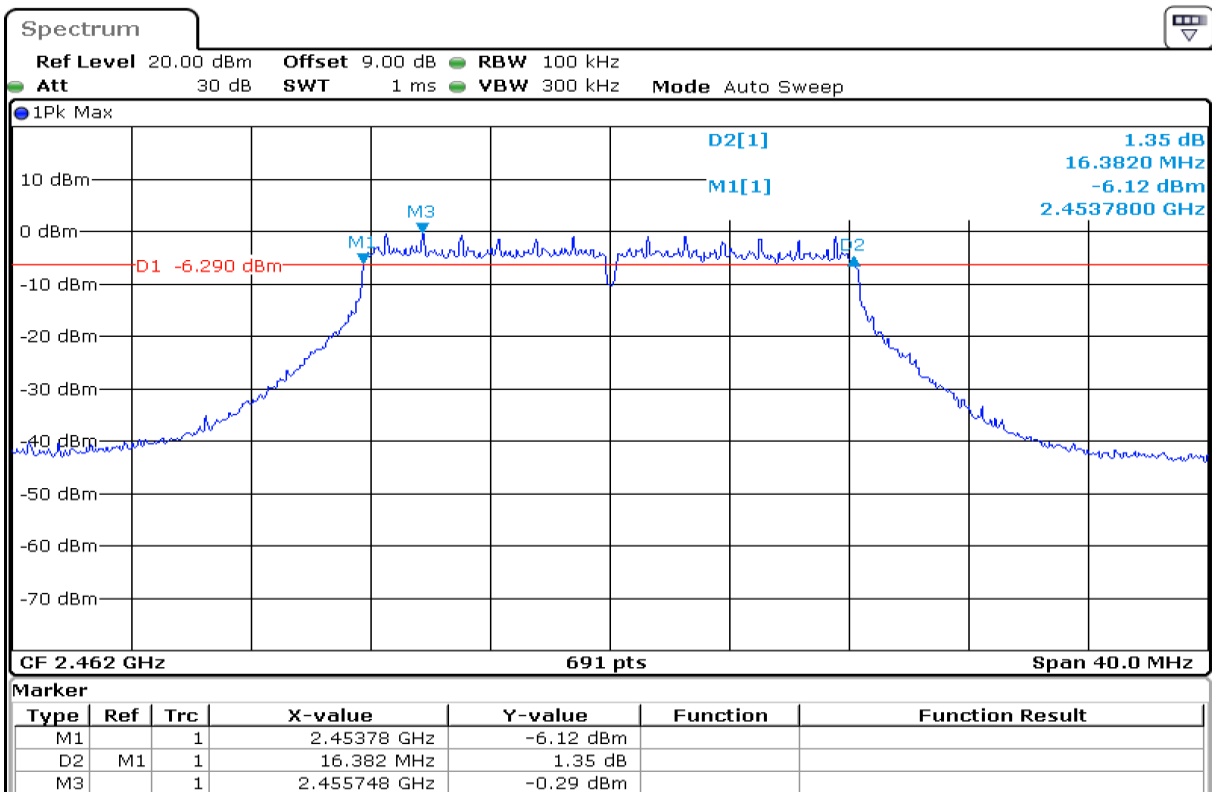

IEEE 802.11n HT20 mode

6dB Bandwidth (CH Low)

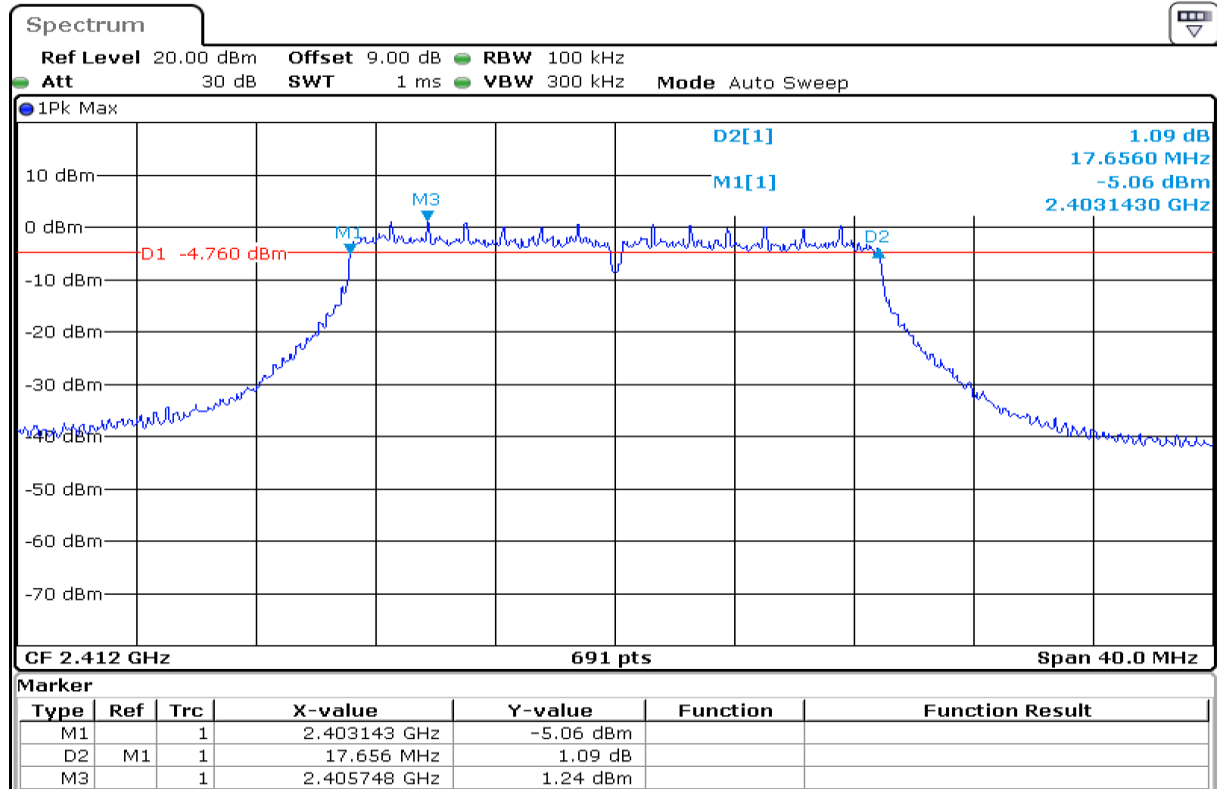

6dB Bandwidth (CH Mid)

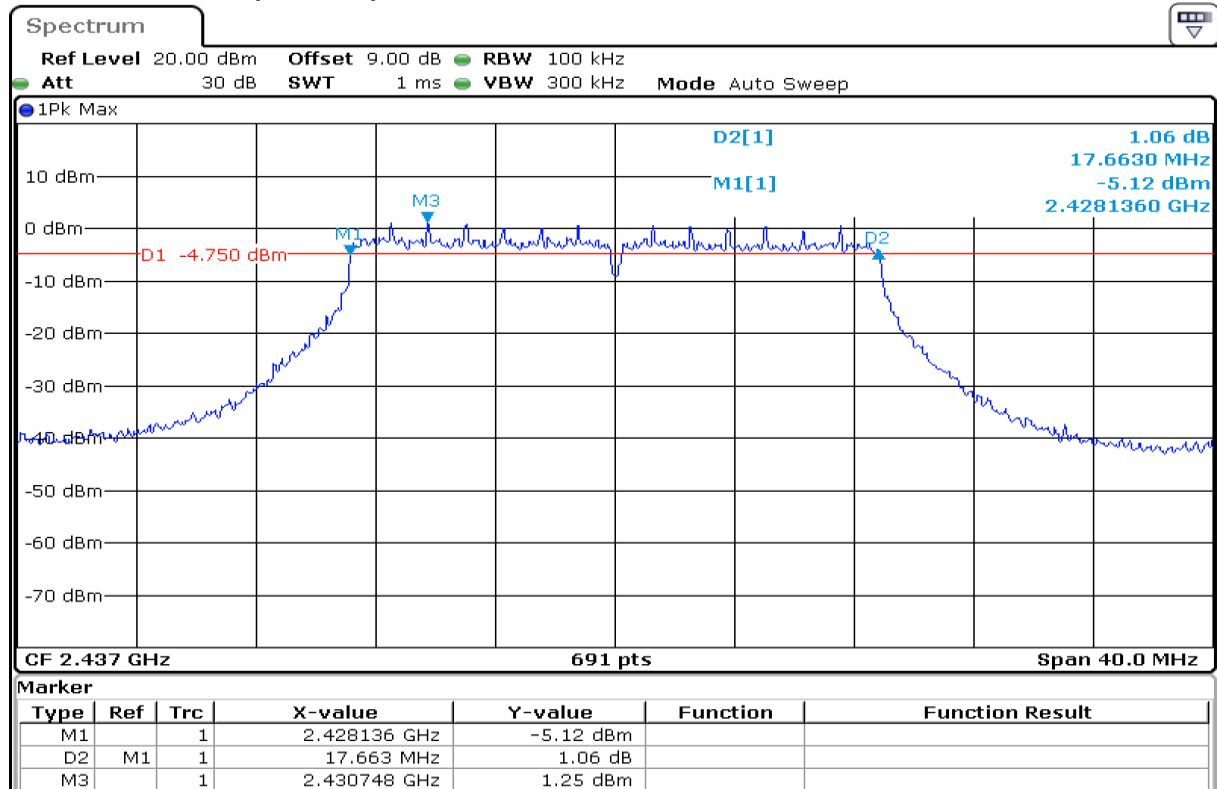

6dB Bandwidth (CH High)

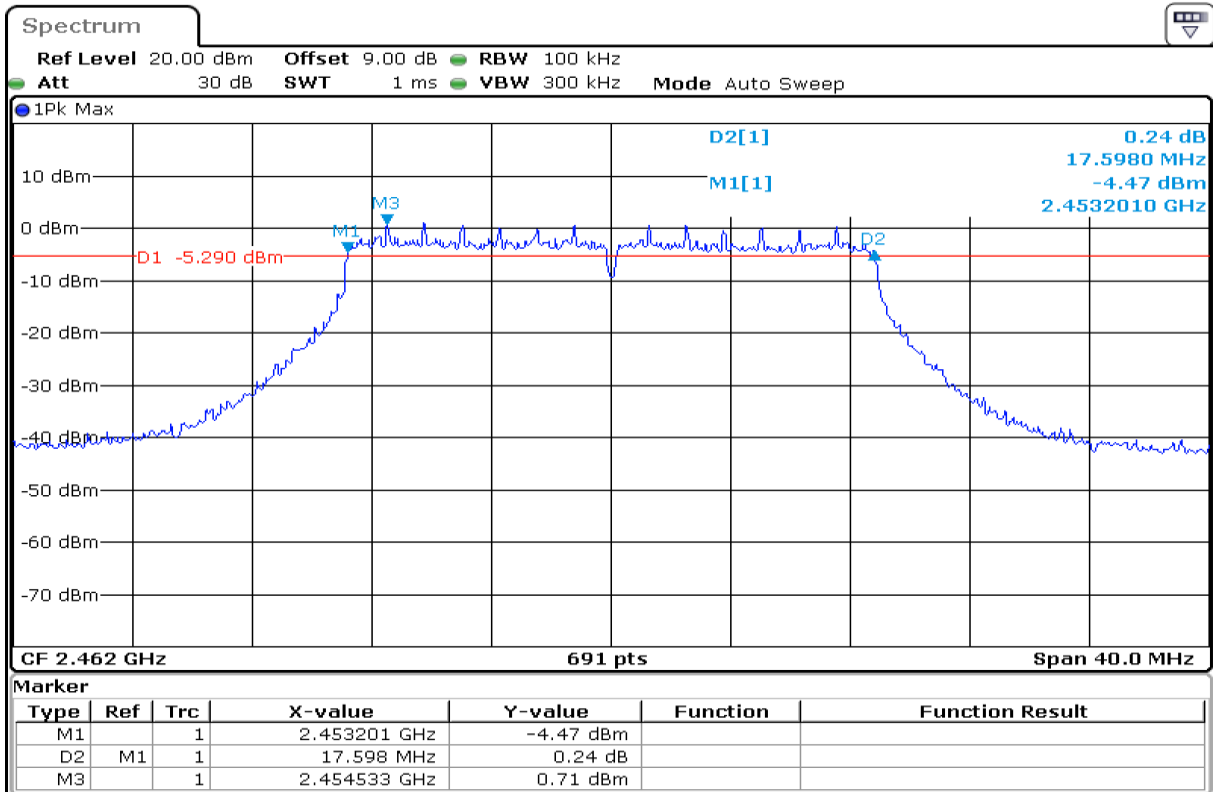

7.2. PEAK POWER

LIMIT

The maximum peak output power of the intentional radiator shall not exceed the following:

1. According to §15.247(b)(3), for systems using digital modulation in the bands of 902-928 MHz, and 2400-2483.5 MHz: 1 Watt.
2. According to §15.247(b)(4), the conducted output power limit specified in paragraph (b) of this section is based on the use of antennas with directional gains that do not exceed 6dBi. Except as shown in paragraph (c) of this section, if transmitting antennas of directional gain greater than 6dBi are used, the conducted output power from the intentional radiator shall be reduced below the stated values in paragraphs (b)(1), (b)(2), and (b)(3) of this section, as appropriate, by the amount in dB that the directional gain of the antenna exceeds 6dBi.

Test Configuration

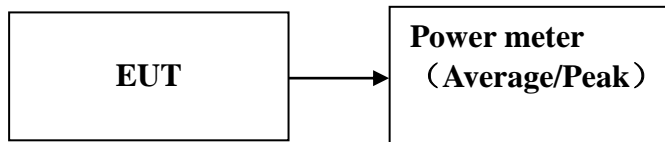

TEST PROCEDURE

1. The EUT transmitter output is connected to the Power meter.
The Power meter is set to the peak power detection.
2. The testing follows the Measurement Procedure ANSI C63.10 section 12.3 PKPM1 Peak-reading power meter method.

TEST RESULTS

No non-compliance noted

Test Data

Test mode: IEEE 802.11b mode

Channel	Frequency (MHz)	peak Output Power (dBm)	Limit (dBm)
Low	2412	18.18	30
Mid	2437	18.36	30
High	2462	18.23	30

Channel	Frequency (MHz)	Average Output Power (dBm)
Low	2412	15.28
Mid	2437	15.32
High	2462	15.25

Test mode: IEEE 802.11g mode

Channel	Frequency (MHz)	peak Output Power (dBm)	Limit (dBm)
Low	2412	21.32	30
Mid	2437	21.44	30
High	2462	21.21	30

Channel	Frequency (MHz)	Average Output Power (dBm)
Low	2412	10.76
Mid	2437	10.81
High	2462	10.78

Test mode: IEEE 802.11n HT20 mode

Channel	Frequency (MHz)	peak Output Power (dBm)	Limit (dBm)
Low	2412	22.03	30
Mid	2437	22.19	30
High	2462	22.07	30

Channel	Frequency (MHz)	Average Output Power (dBm)
Low	2412	11.92
Mid	2437	11.99
High	2462	11.96

Remark: Duty factor has been offset with cable loss

7.3. PEAK POWER SPECTRAL DENSITY

LIMIT

1. According to §15.247(e), for digitally modulated systems, the power spectral density conducted from the intentional radiator to the antenna shall not be greater than 8 dBm in any 3 kHz band during any time interval of continuous transmission.

2. According to §15.247(f), the digital modulation operation of the hybrid system, with the frequency hopping turned off, shall comply with the power density requirements of paragraph (d) of this section.

Test Configuration

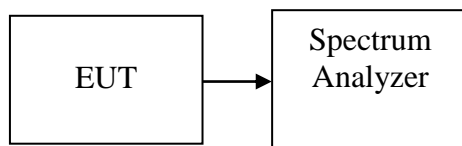

TEST PROCEDURE

1. Place the EUT on the table and set it in transmitting mode. Remove the antenna from the EUT and then connect a low loss RF cable from the antenna port to the spectrum analyzer.
2. Set the spectrum analyzer as RBW = 3 kHz, VBW = 10 kHz, Span = 1.5 times the DTS bandwidth, Sweep = auto
3. Record the max reading.
4. Repeat the above procedure until the measurements for all frequencies are completed.

TEST RESULTS

No non-compliance noted

Test Data

Test mode: IEEE 802.11b mode

Channel	Frequency (MHz)	PPSD (dBm)	Limit (dBm)	Result
Low	2412	-4.17	8.00	PASS
Mid	2437	-5.41	8.00	PASS
High	2462	-5.71	8.00	PASS

Test mode: IEEE 802.11g mode

Channel	Frequency (MHz)	PPSD (dBm)	Limit (dBm)	Result
Low	2412	-13.15	8.00	PASS
Mid	2437	-13.88	8.00	PASS
High	2462	-14.31	8.00	PASS

Test mode: IEEE 802.11n HT20 mode

Channel	Frequency (MHz)	PPSD (dBm)	Limit (dBm)	Result
Low	2412	-12.06	8.00	PASS
Mid	2437	-12.34	8.00	PASS
High	2462	-12.93	8.00	PASS

Test Plot

IEEE 802.11b mode

PPSD (CH Low)

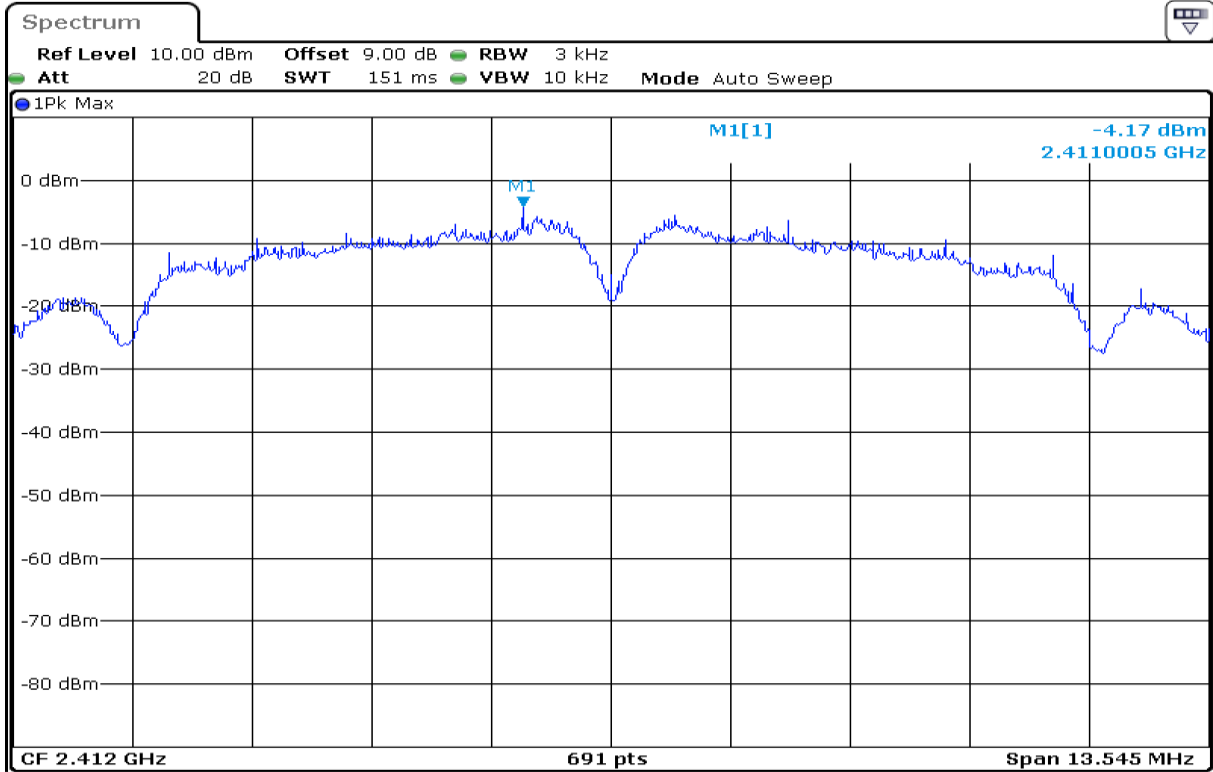

PPSD(CH Mid)

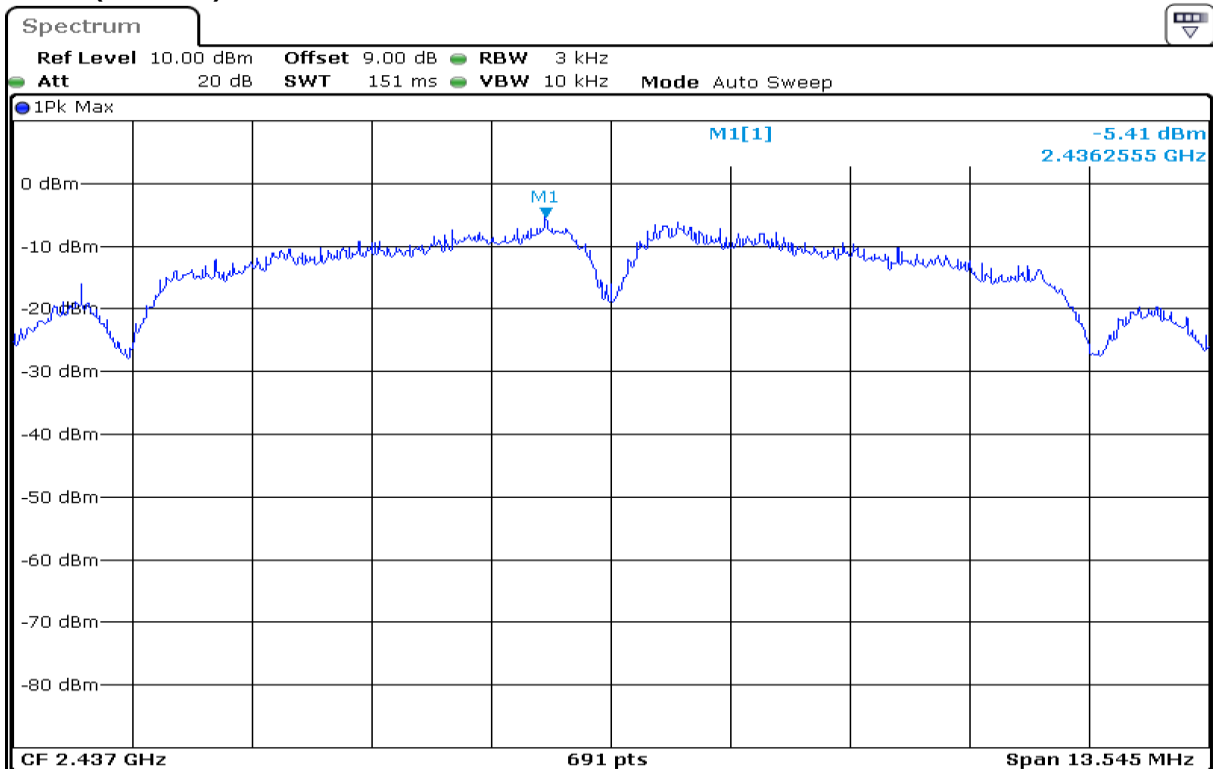

PPSD (CH High)

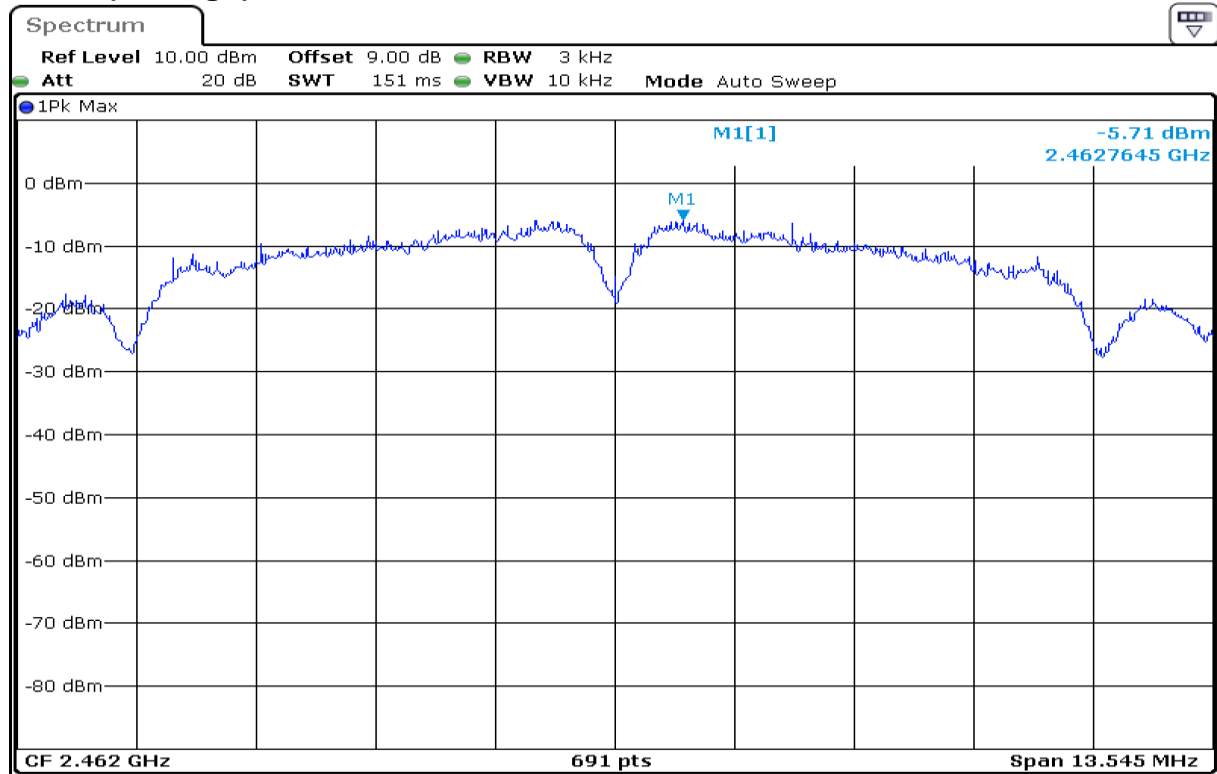

IEEE 802.11g mode PPSD (CH Low)

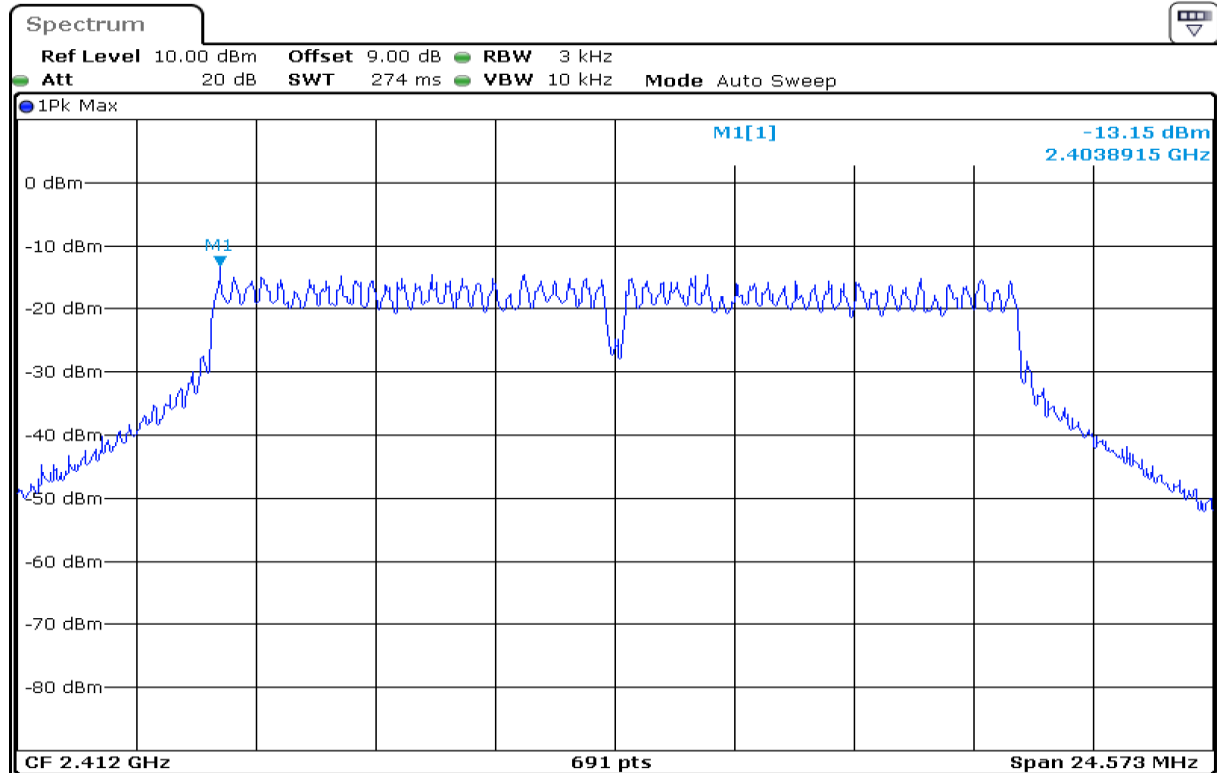

PPSD (CH Mid)

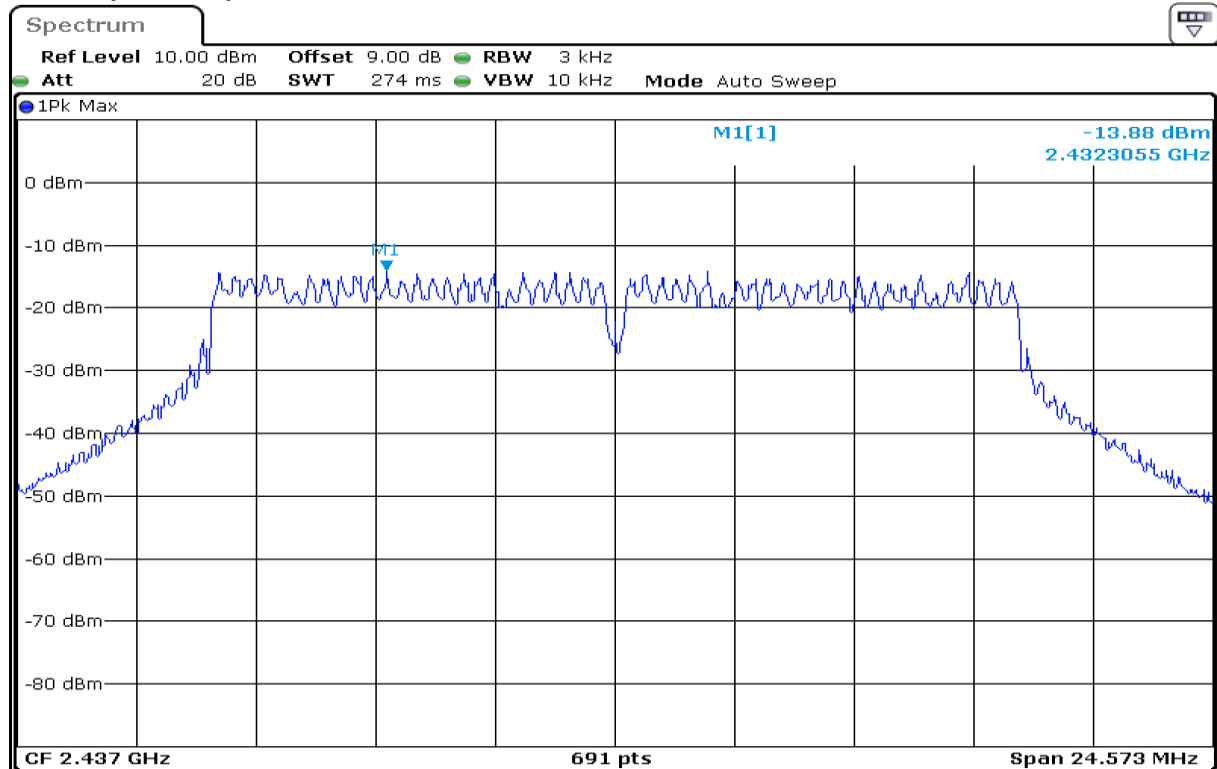

PPSD (CH High)

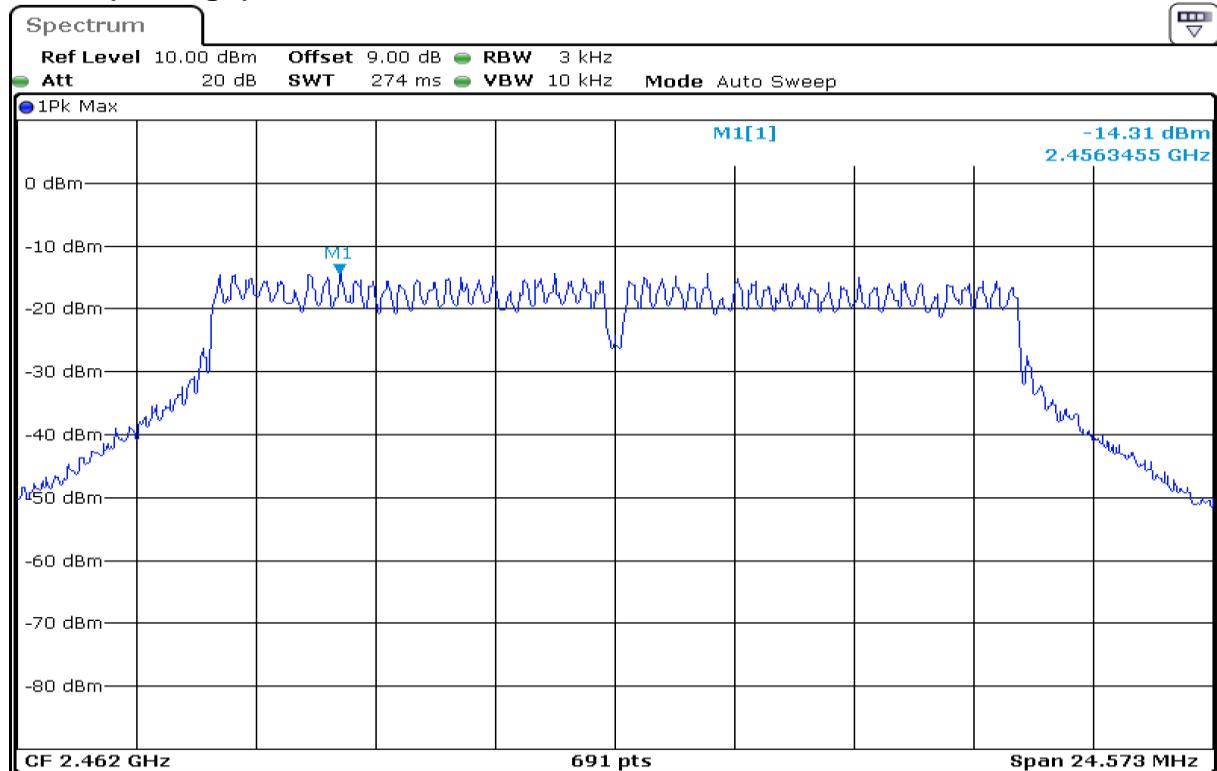

IEEE 802.11n HT20 mode PPSD (CH Low)

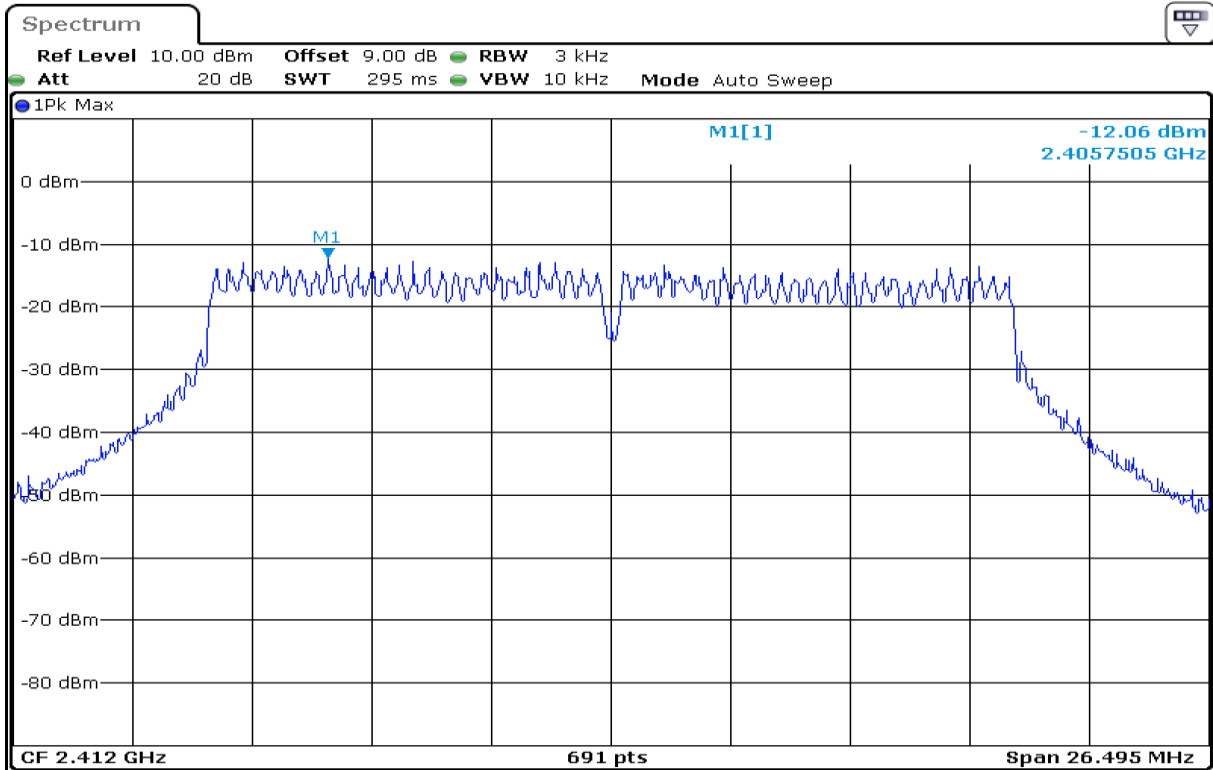

PPSD (CH Mid)

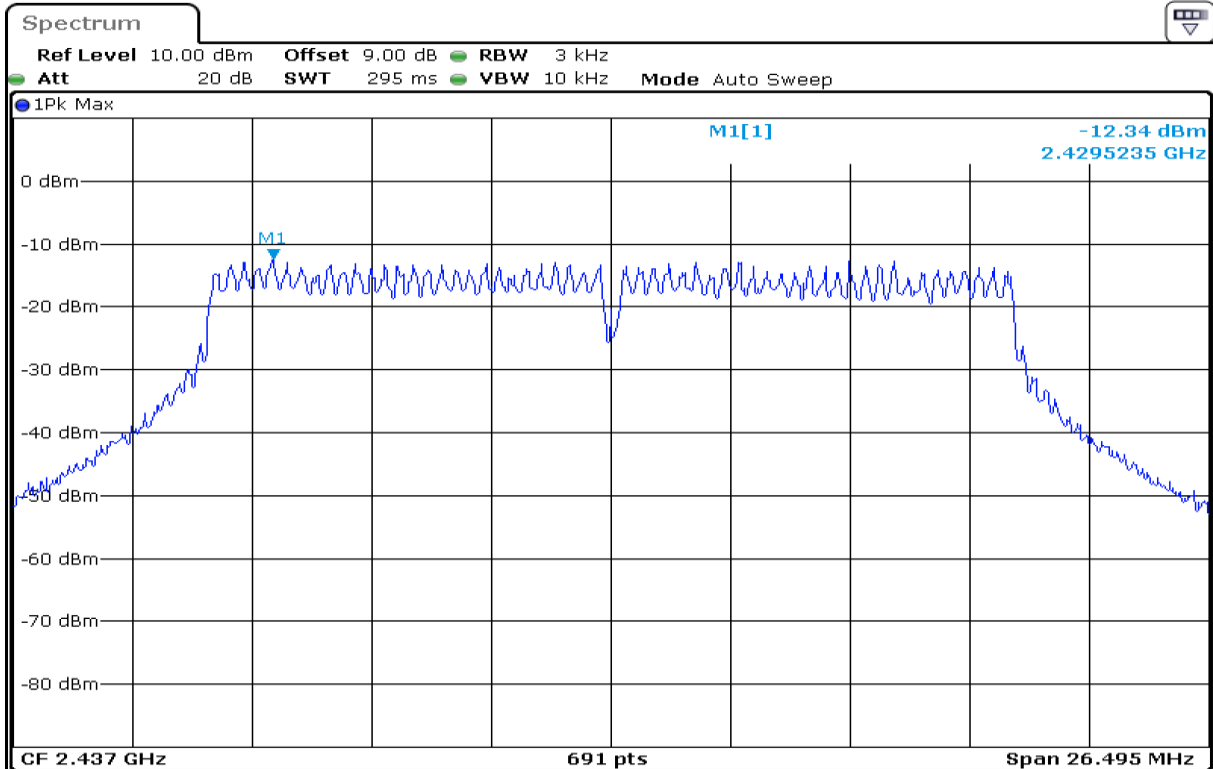

PPSD (CH High)

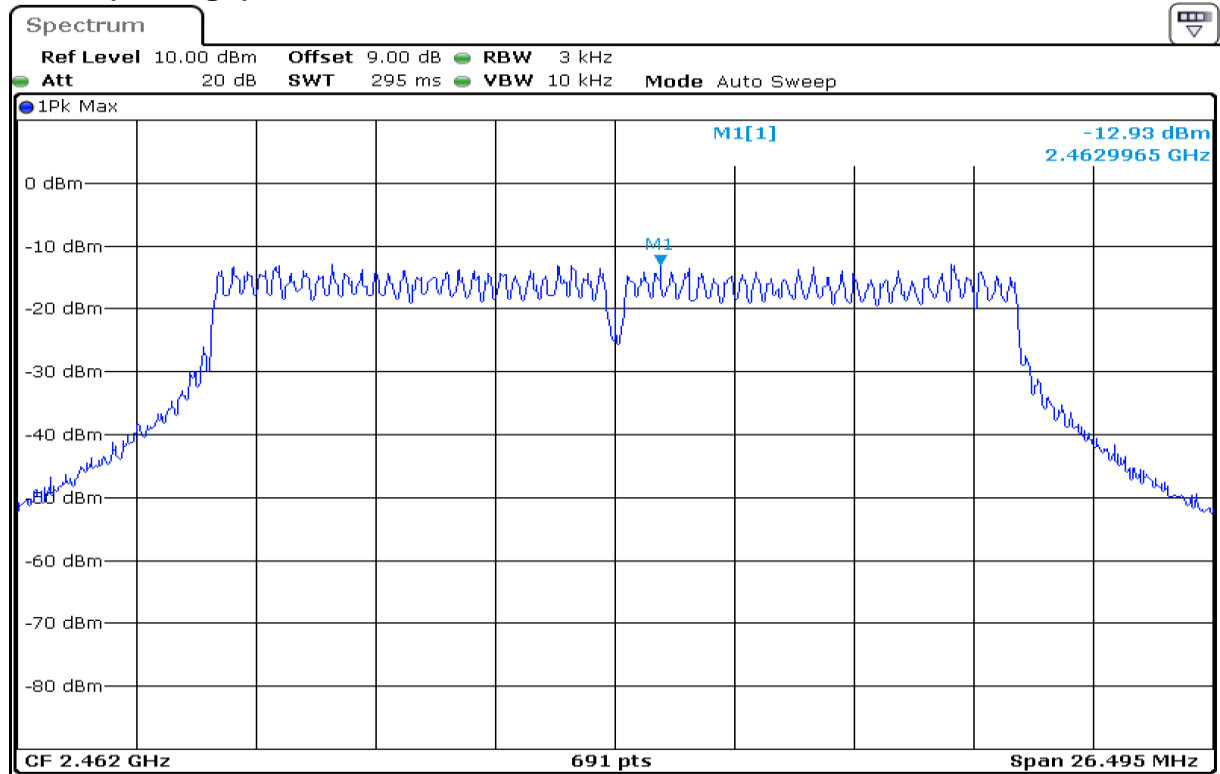

7.4.SPURIOUS EMISSIONS

Conducted Measurement

LIMIT

According to §15.247(d), in any 100 kHz bandwidth outside the frequency bands in which the spread spectrum intentional radiator is operating, the radio frequency power that is produced by the intentional radiator shall be at least 20 dB below that in the 100 kHz bandwidth within the band that contains the highest level of the desired power, based on either an RF conducted or a radiated measurement, provided the transmitter demonstrates compliance with the peak conducted power limits. In addition, radiated emissions which fall in the restricted bands, as defined in §15.205(a), must also comply with the radiated emission limits specified in 15.209(a) (see Section 15.205(c)).

Test Configuration

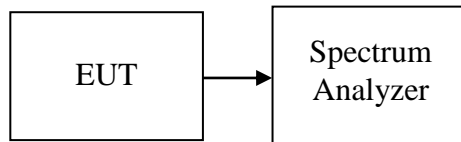

TEST PROCEDURE

Conducted RF measurements of the transmitter output were made to confirm that the EUT antenna port conducted emissions meet the specified limit and to identify any spurious signals that require further investigation or measurements on the radiated emissions site.

The transmitter output is connected to the spectrum analyzer. The resolution bandwidth is set to 100 kHz. The video bandwidth is set to 300 kHz.

Measurements are made over the 30MHz to 25GHz range with the transmitter set to the lowest, middle, and highest channels.

TEST RESULTS

No non-compliance noted

Test Plot
OUT-OF-BAND SPURIOUS EMISSIONS-CONDUCTED MEASUREMENT
IEEE 802.11b mode
CH Low

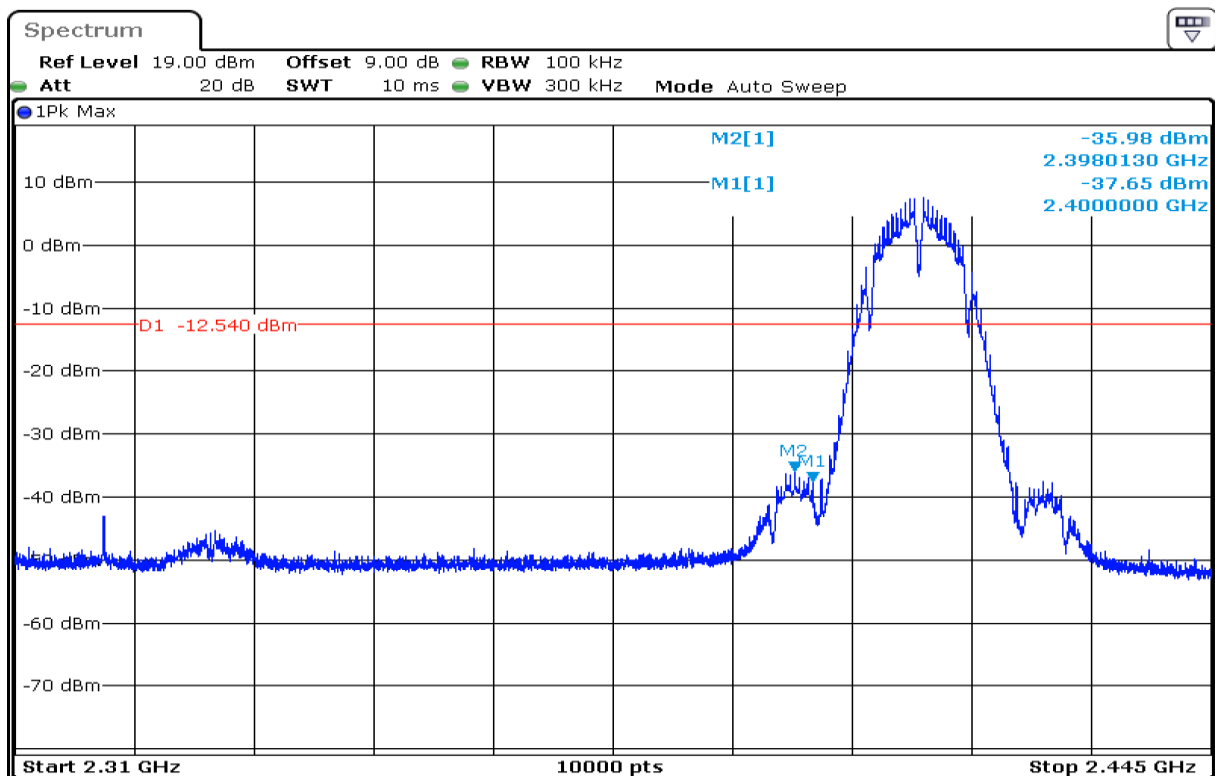
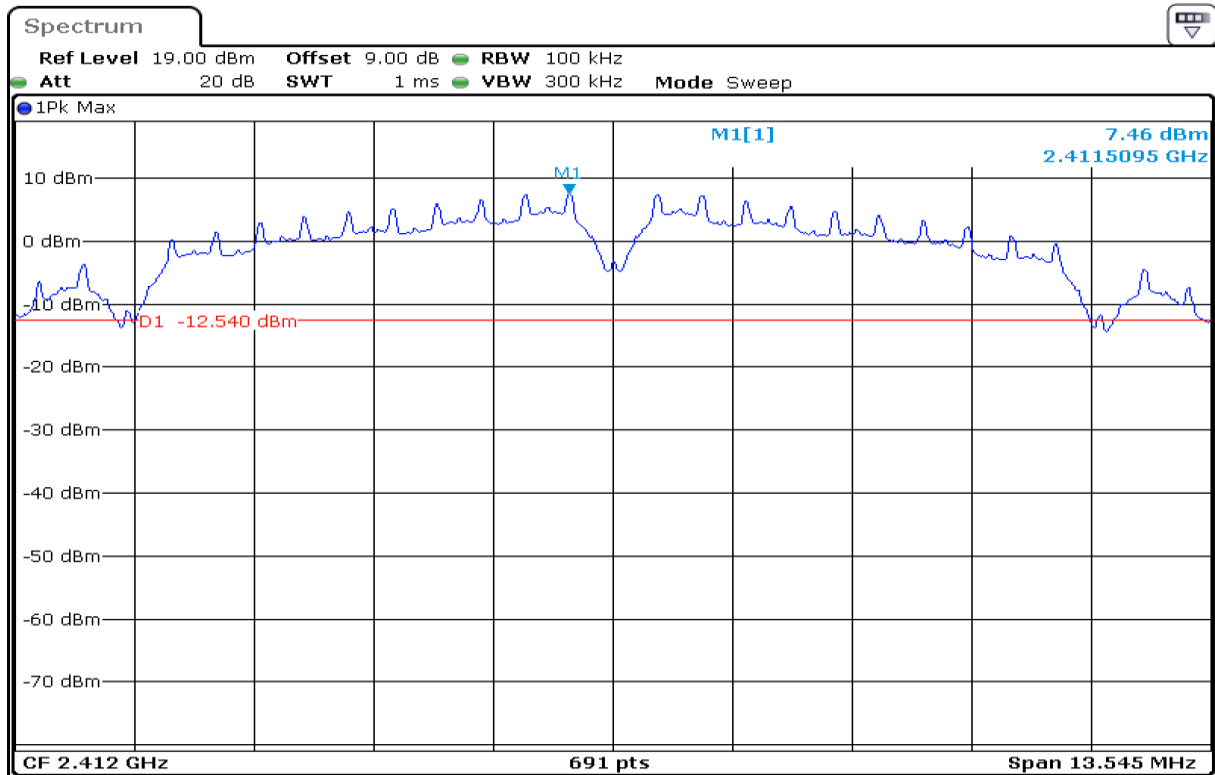

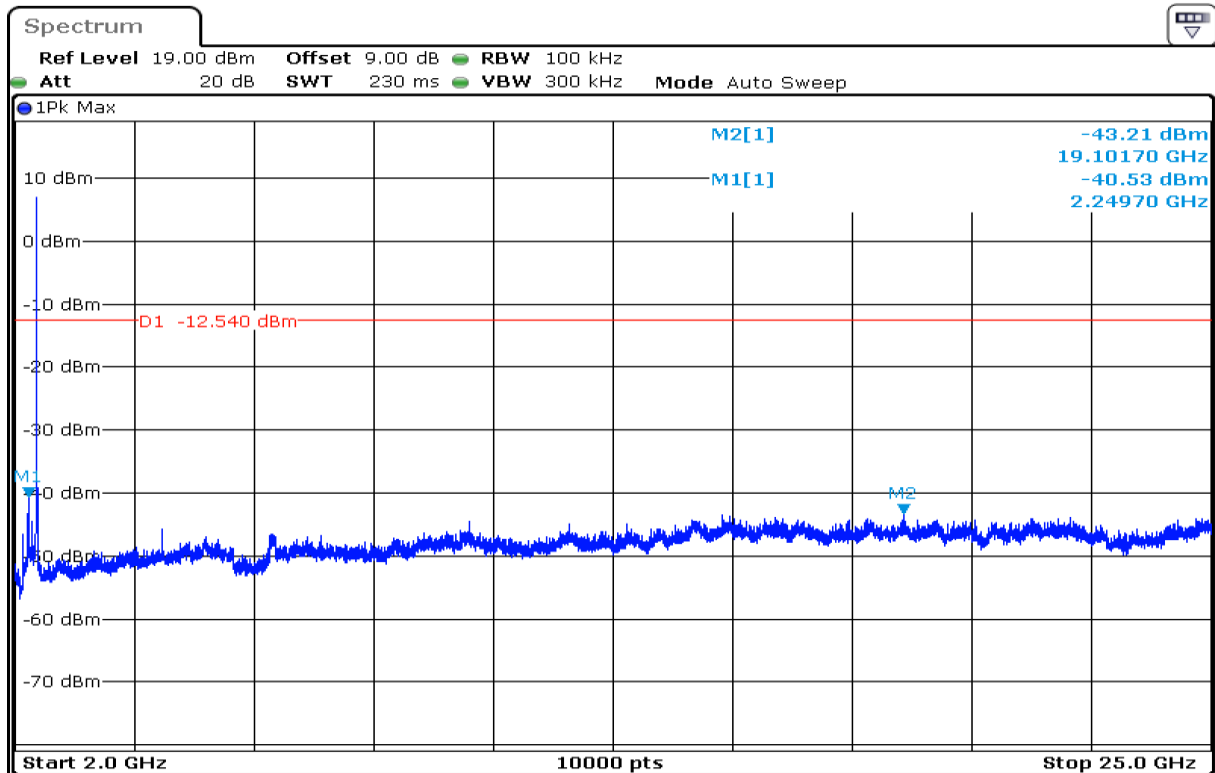
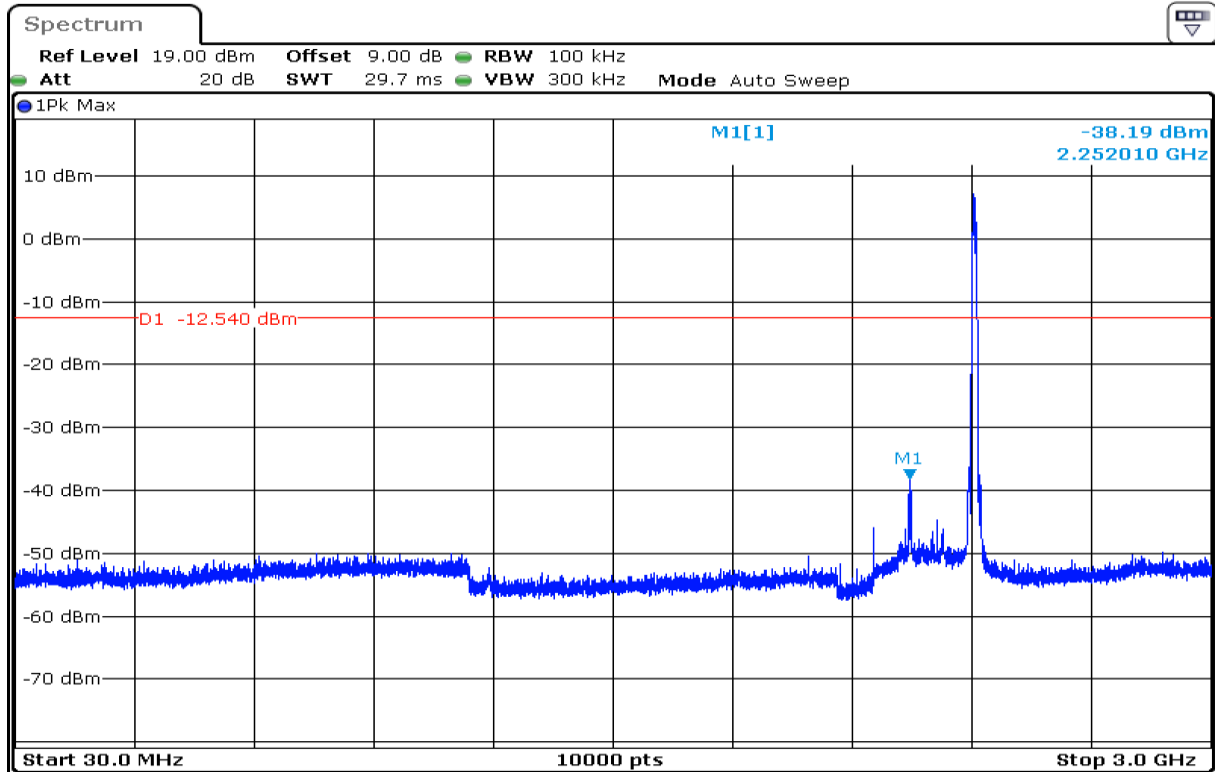

CH Mid

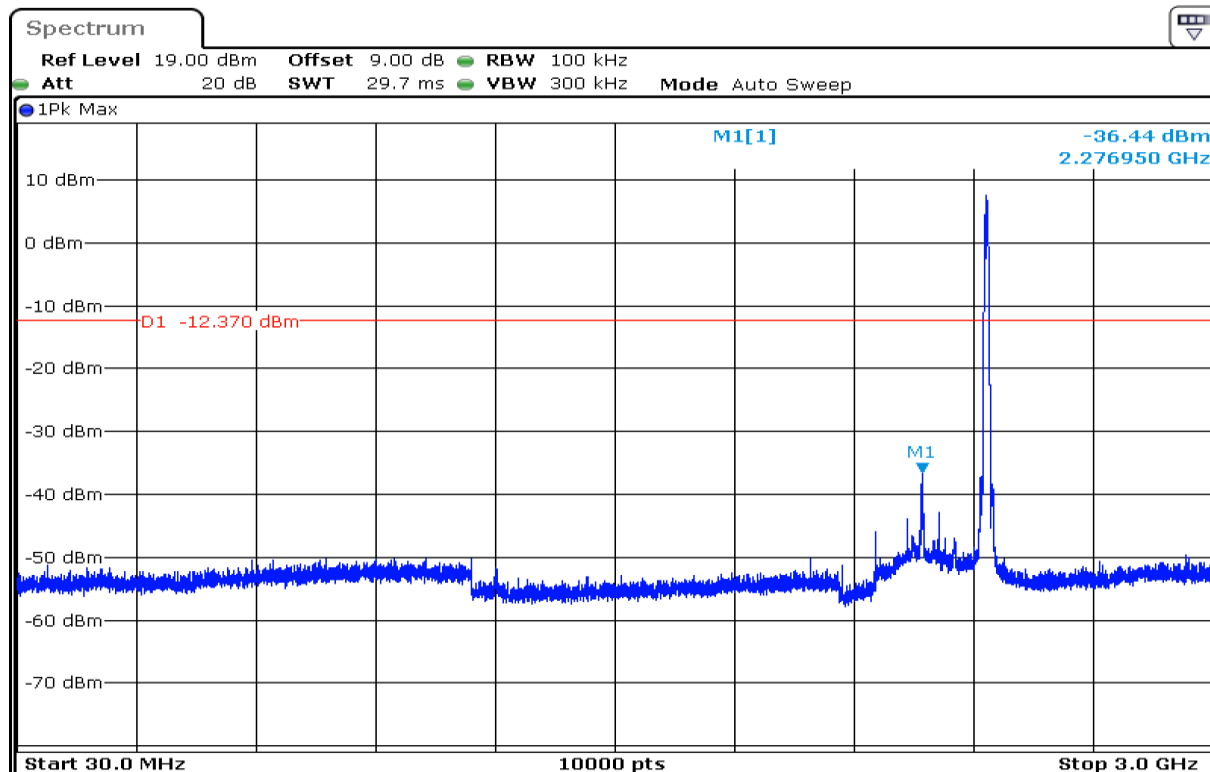
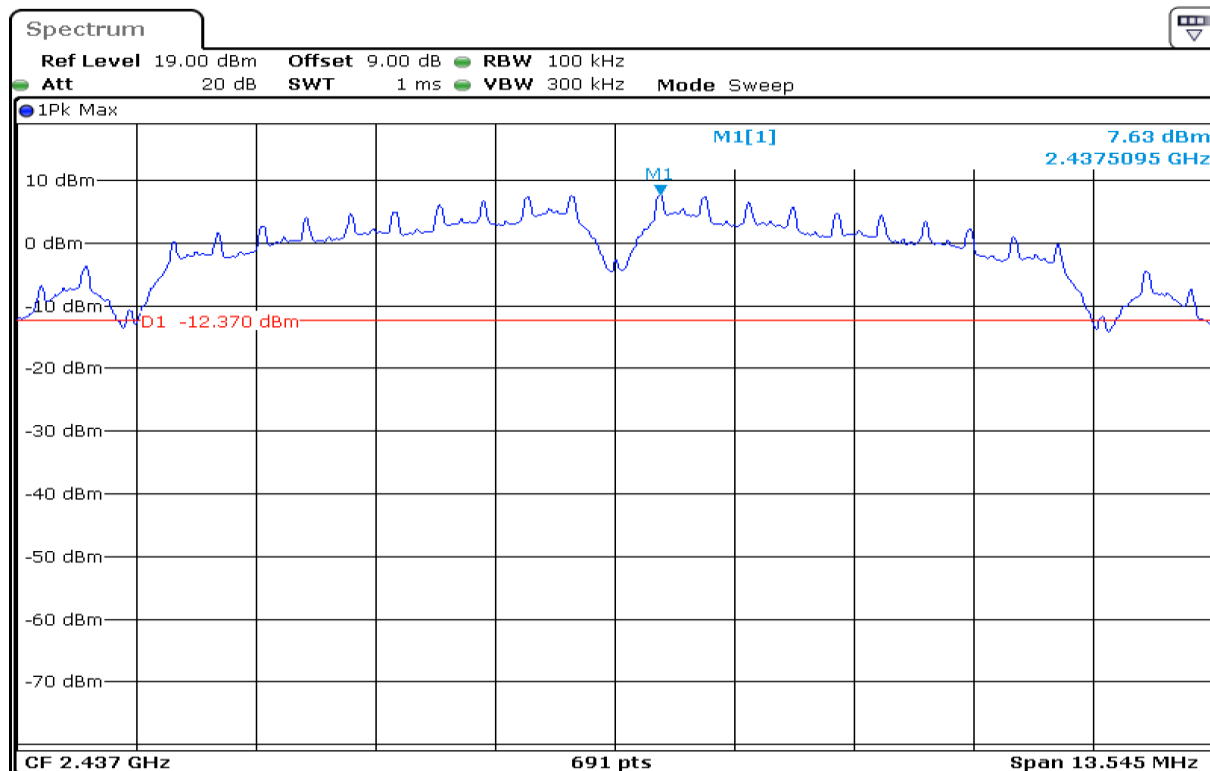

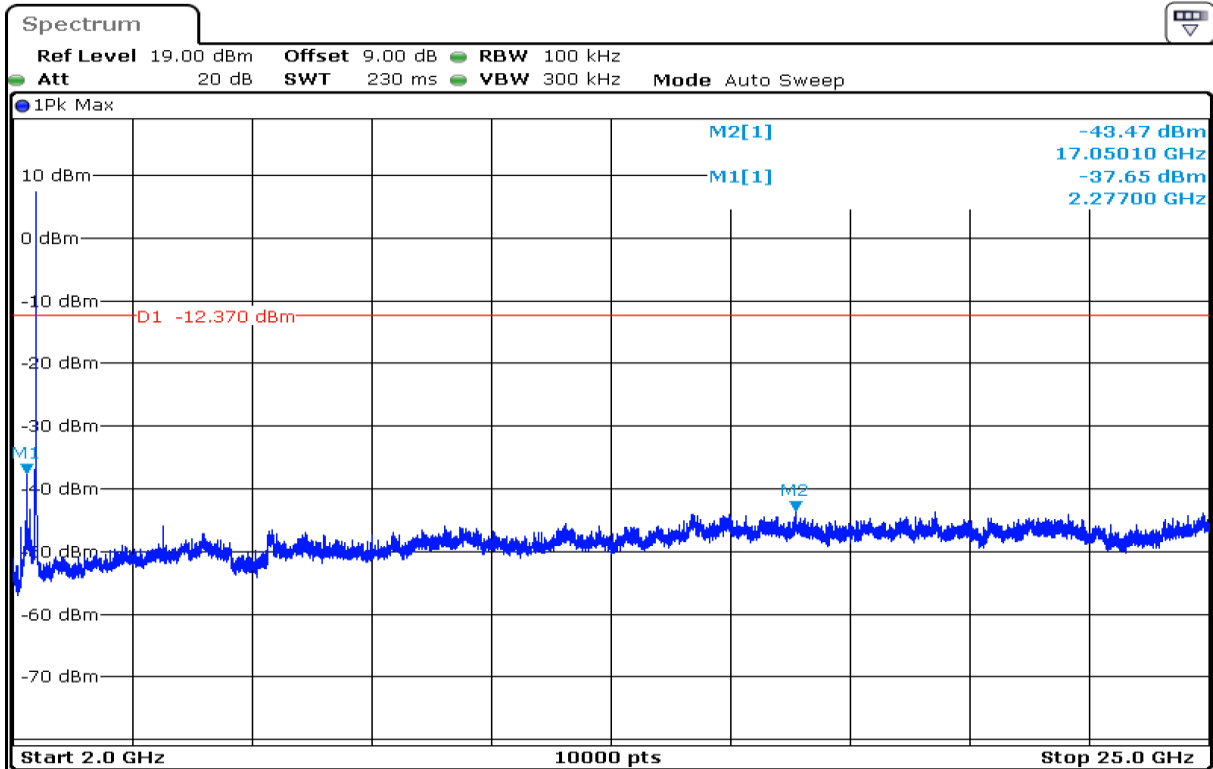

CH High

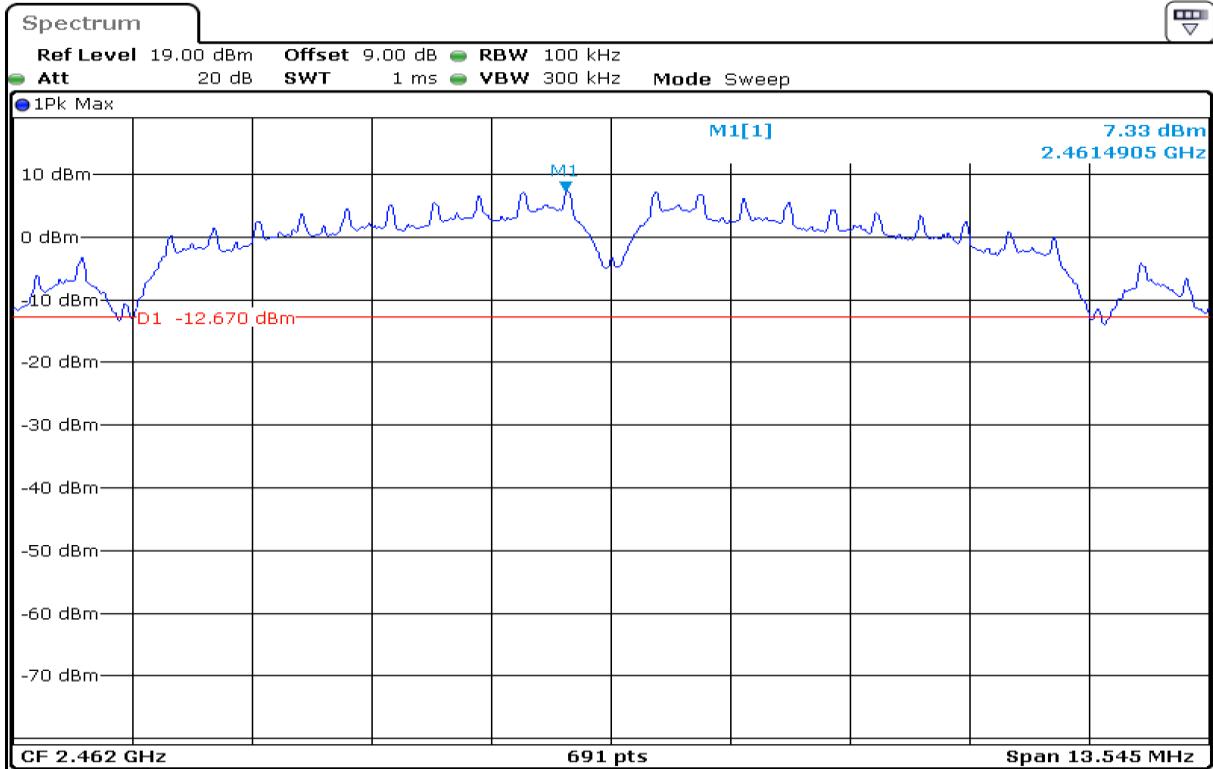

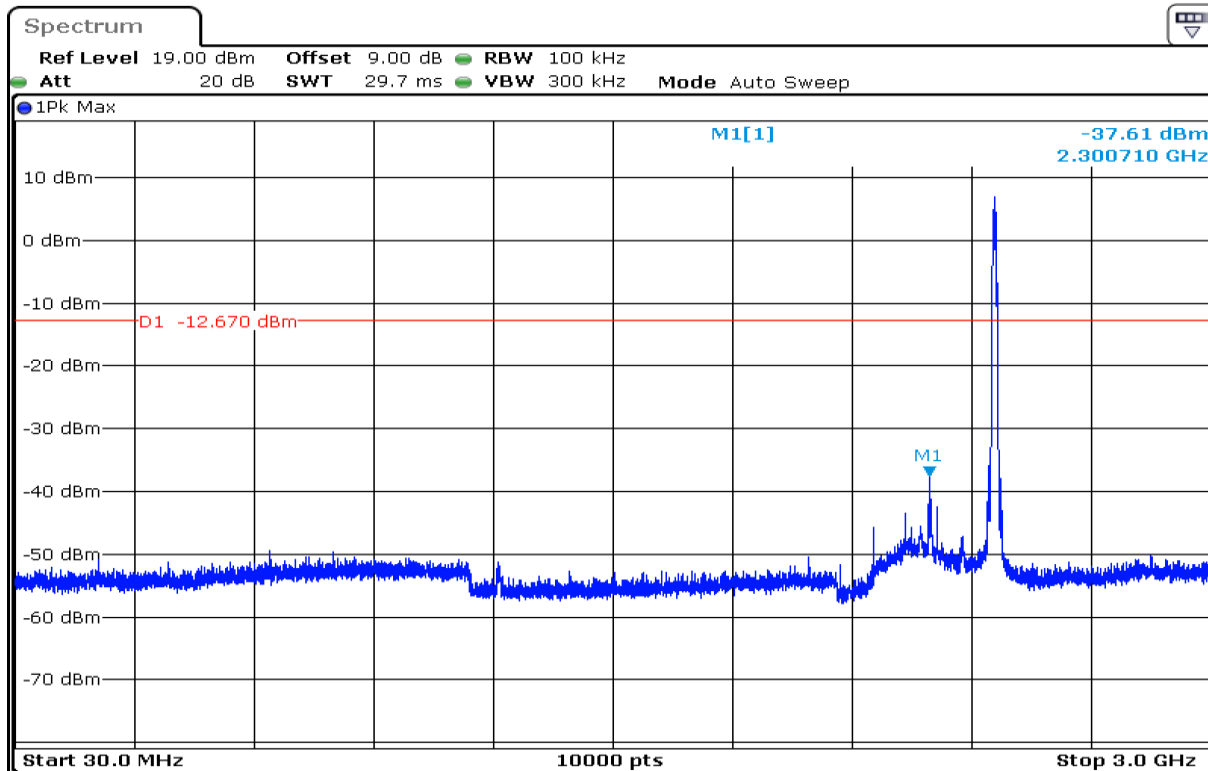
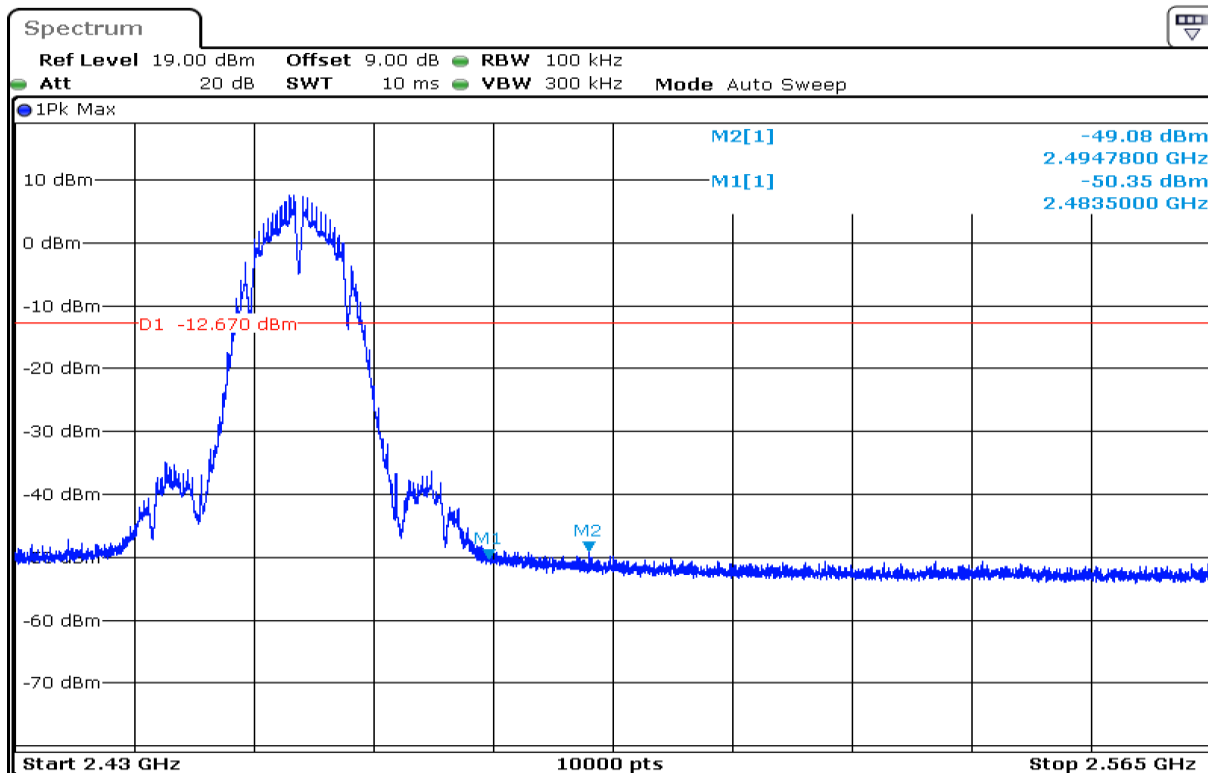

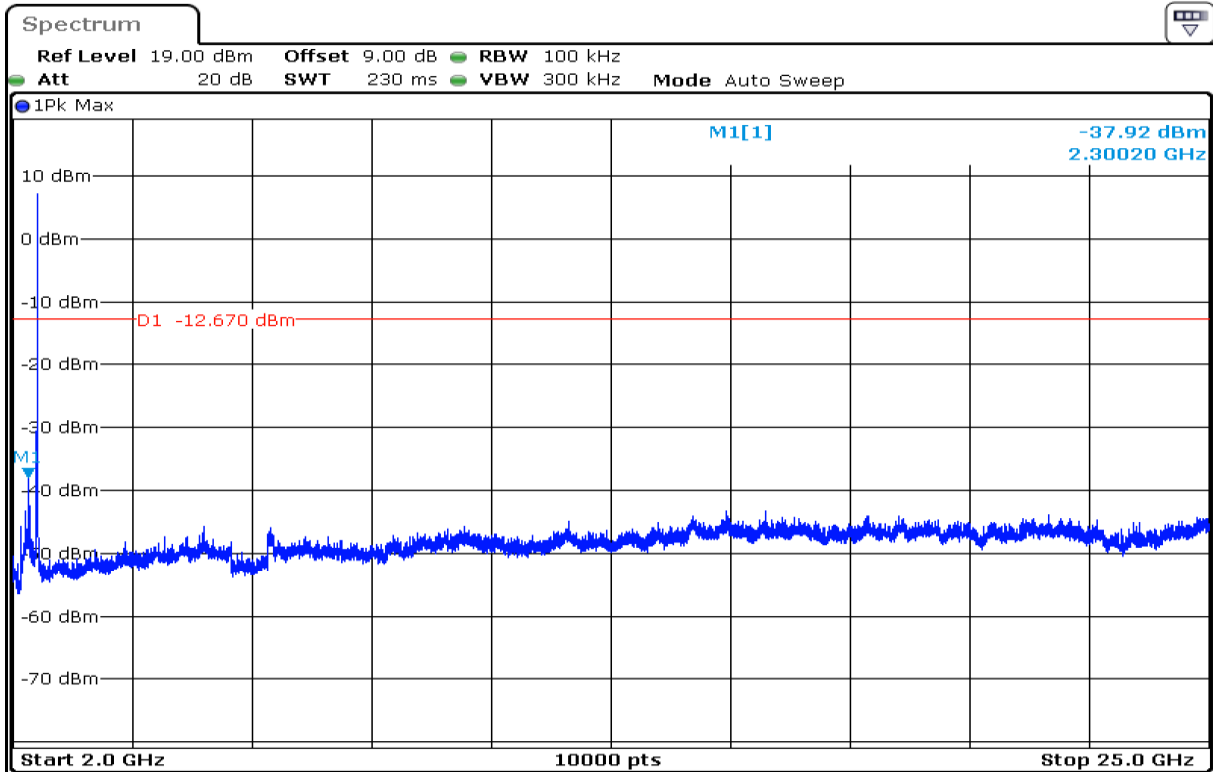

IEEE 802.11g mode CH Low

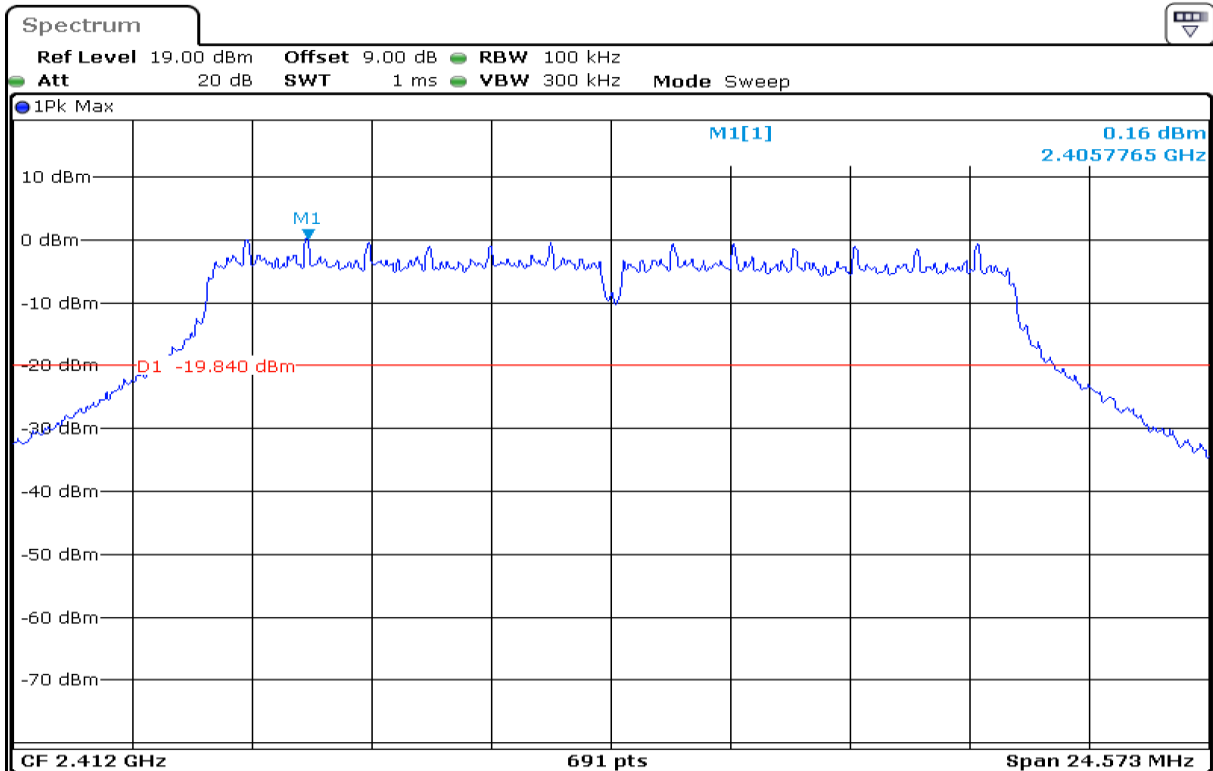

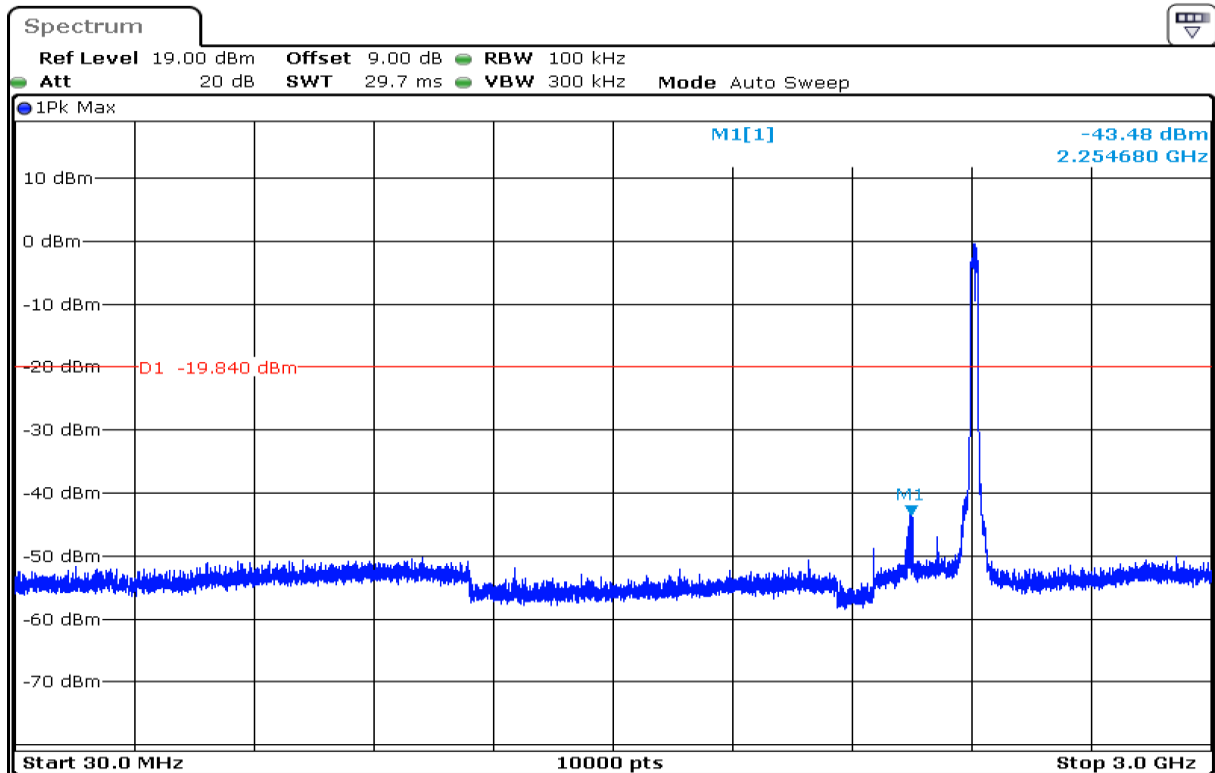
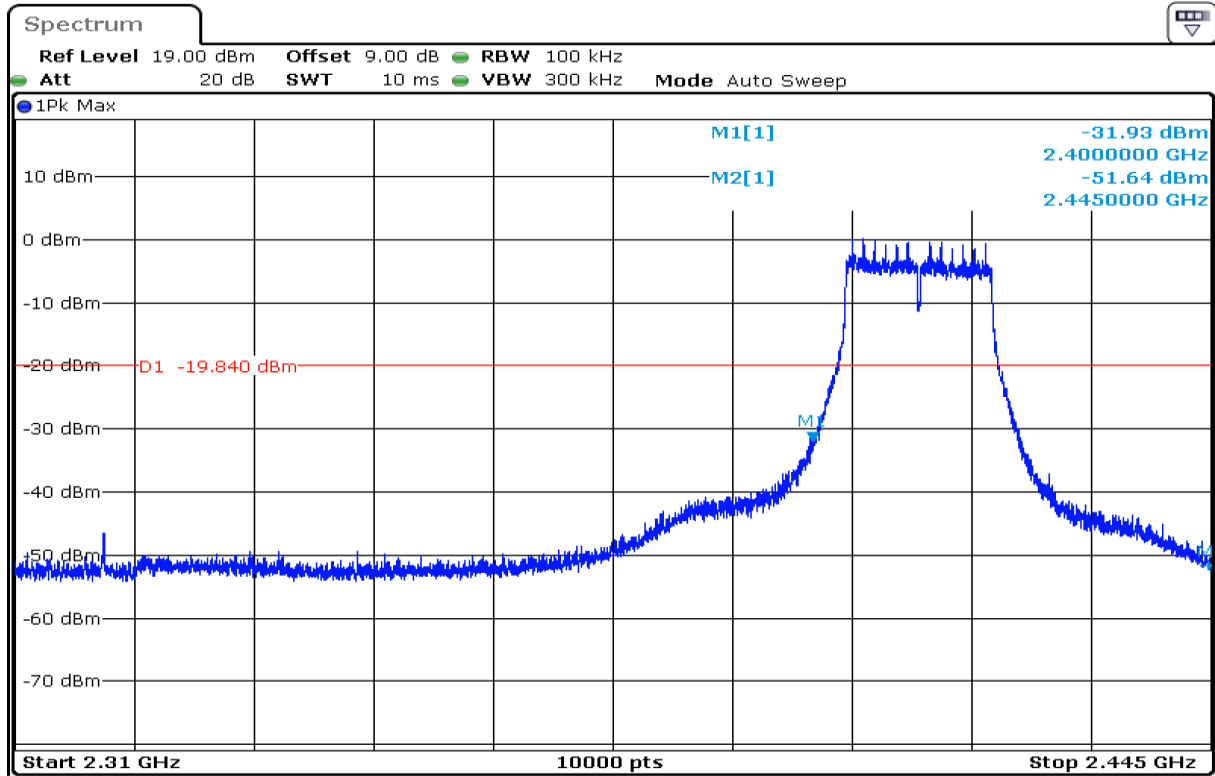

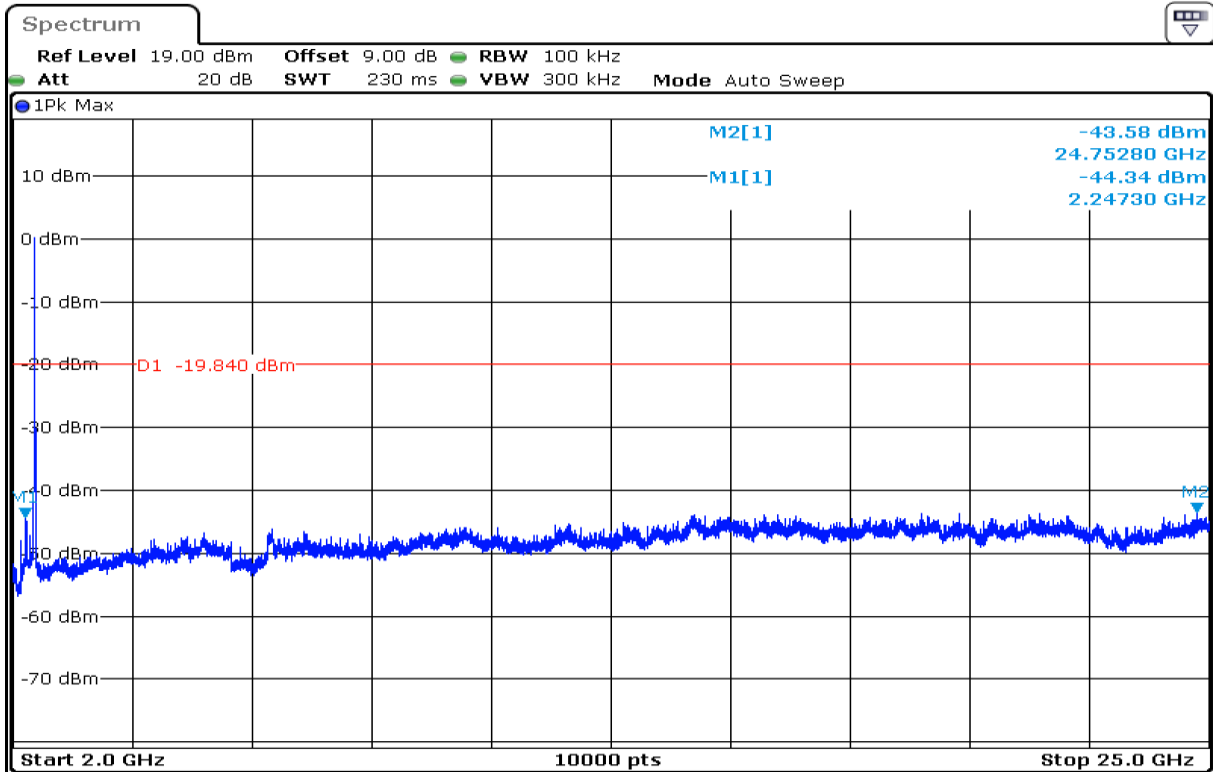

CH Mid

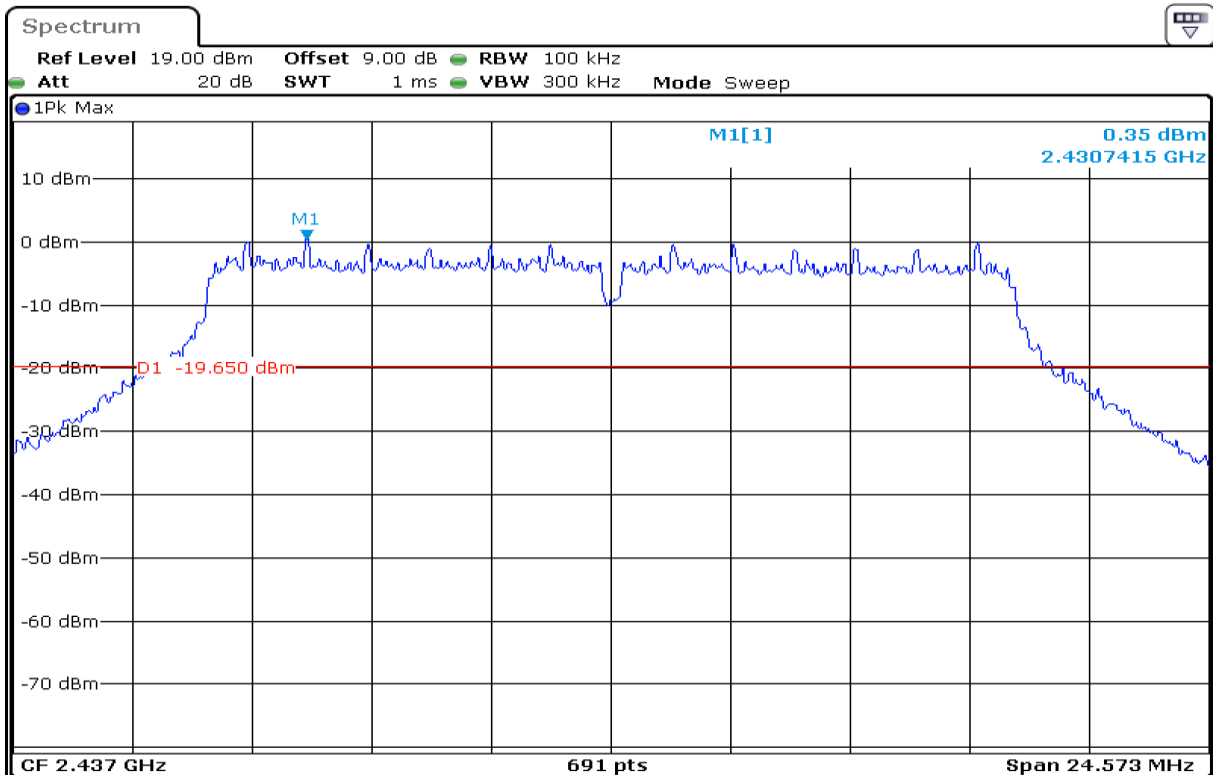

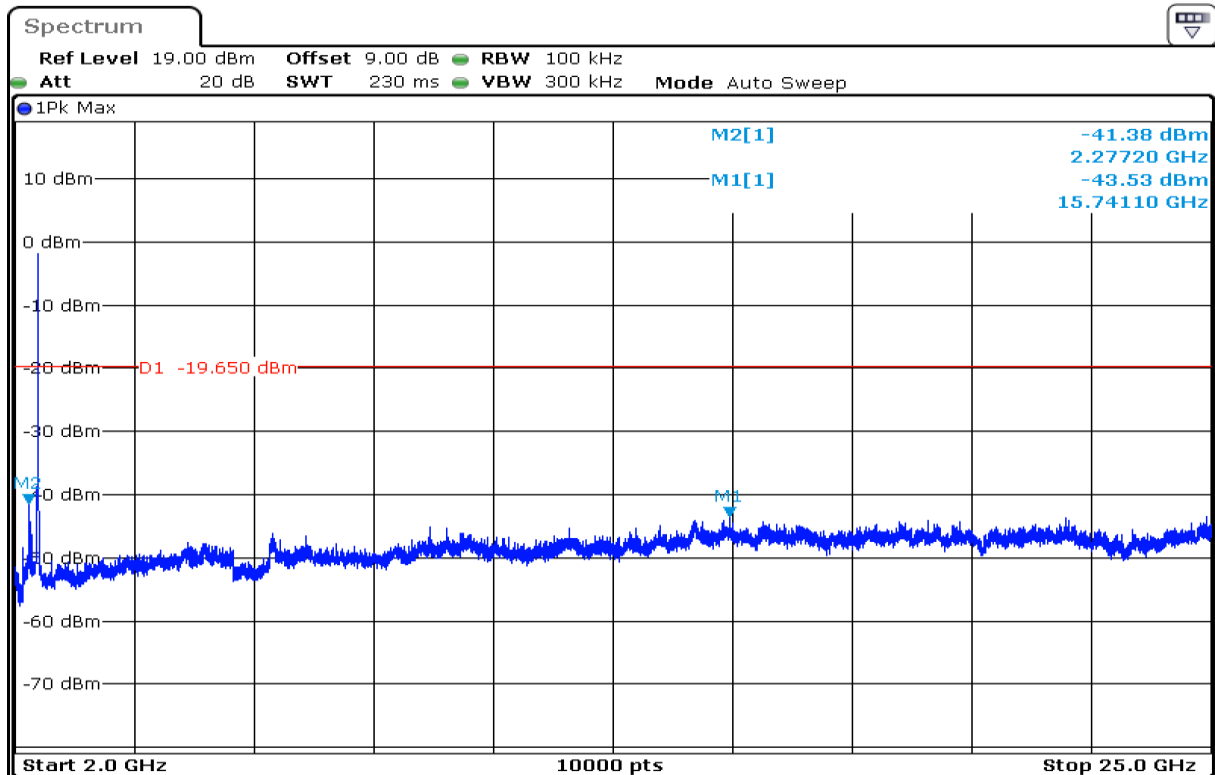
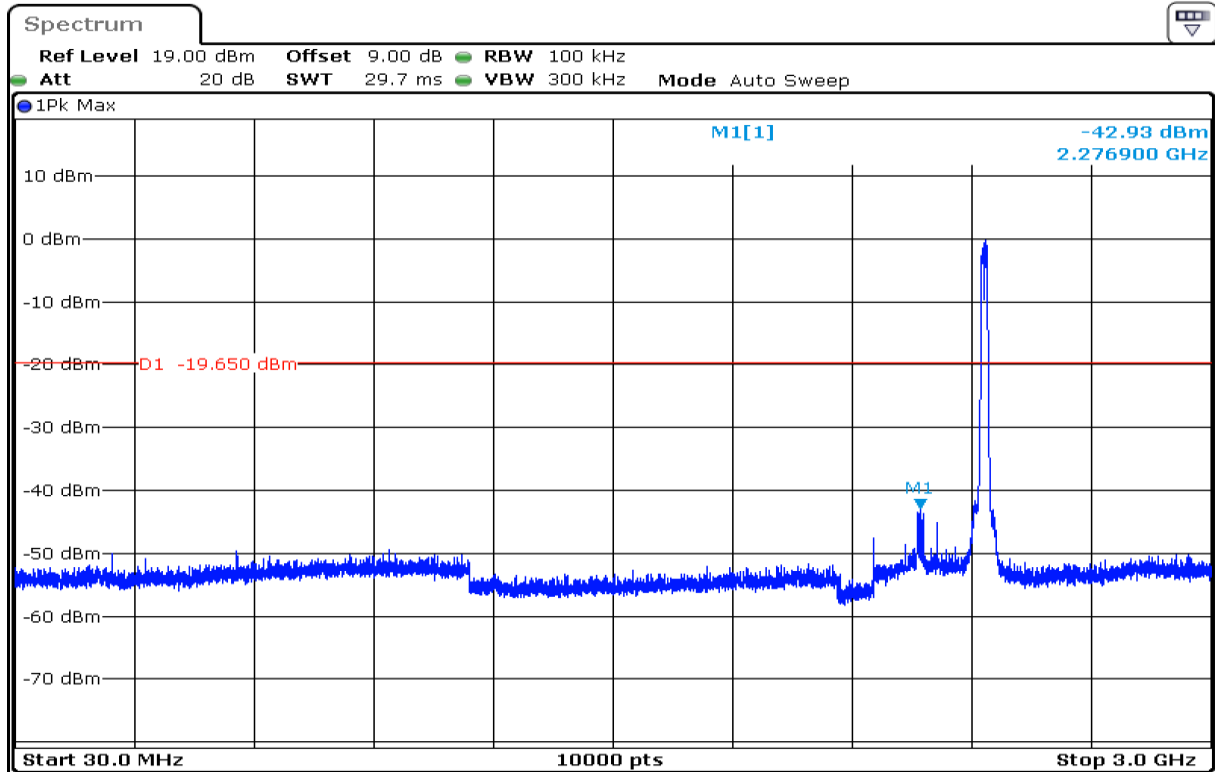

CH High

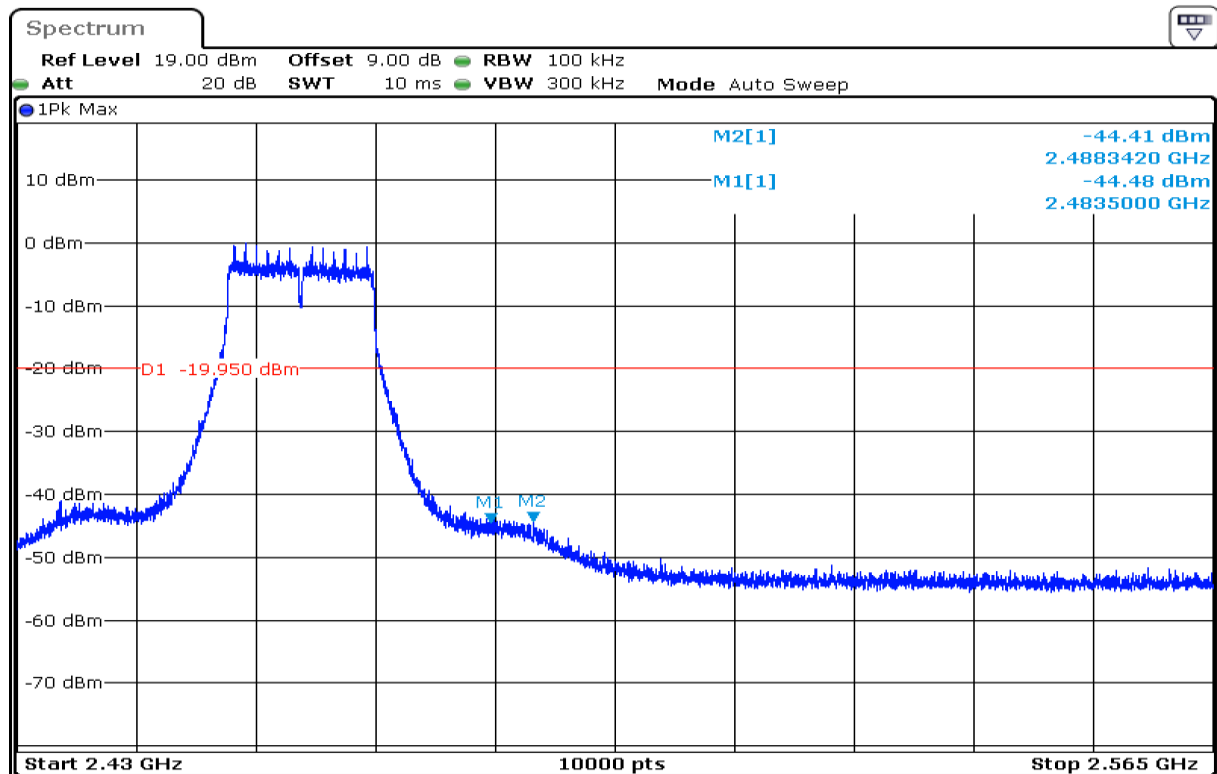
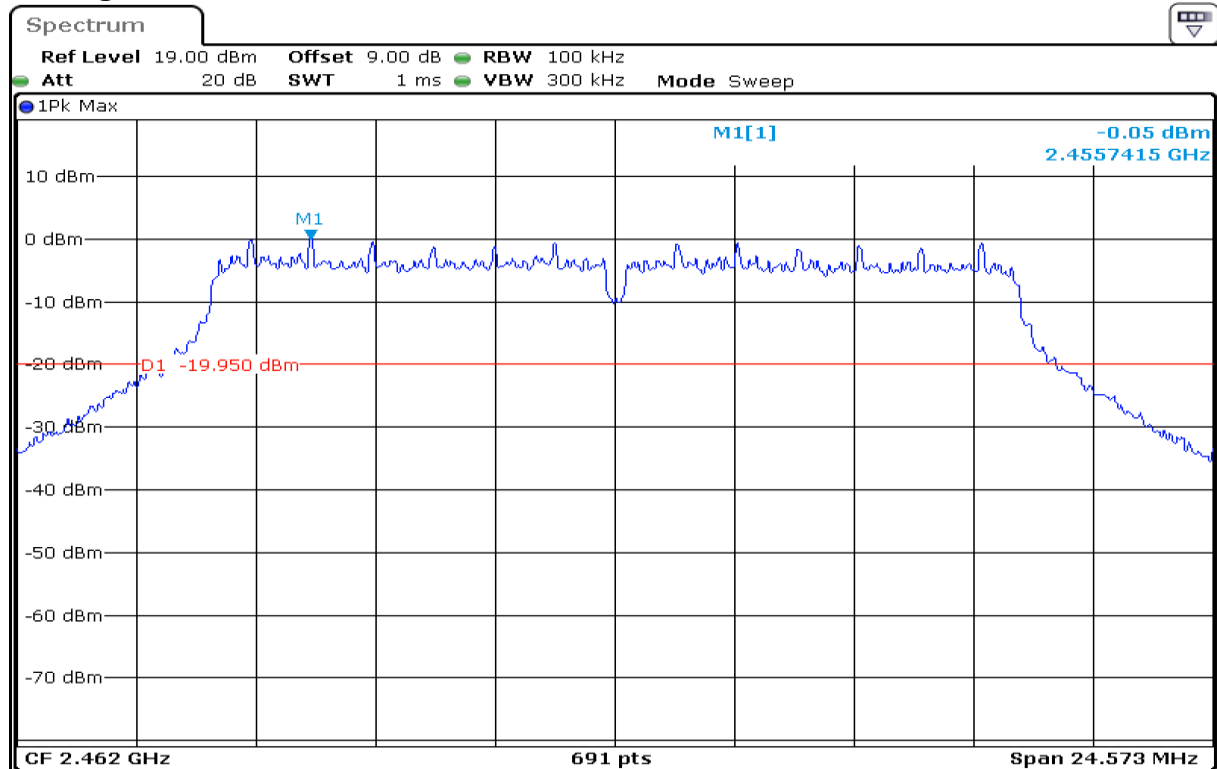

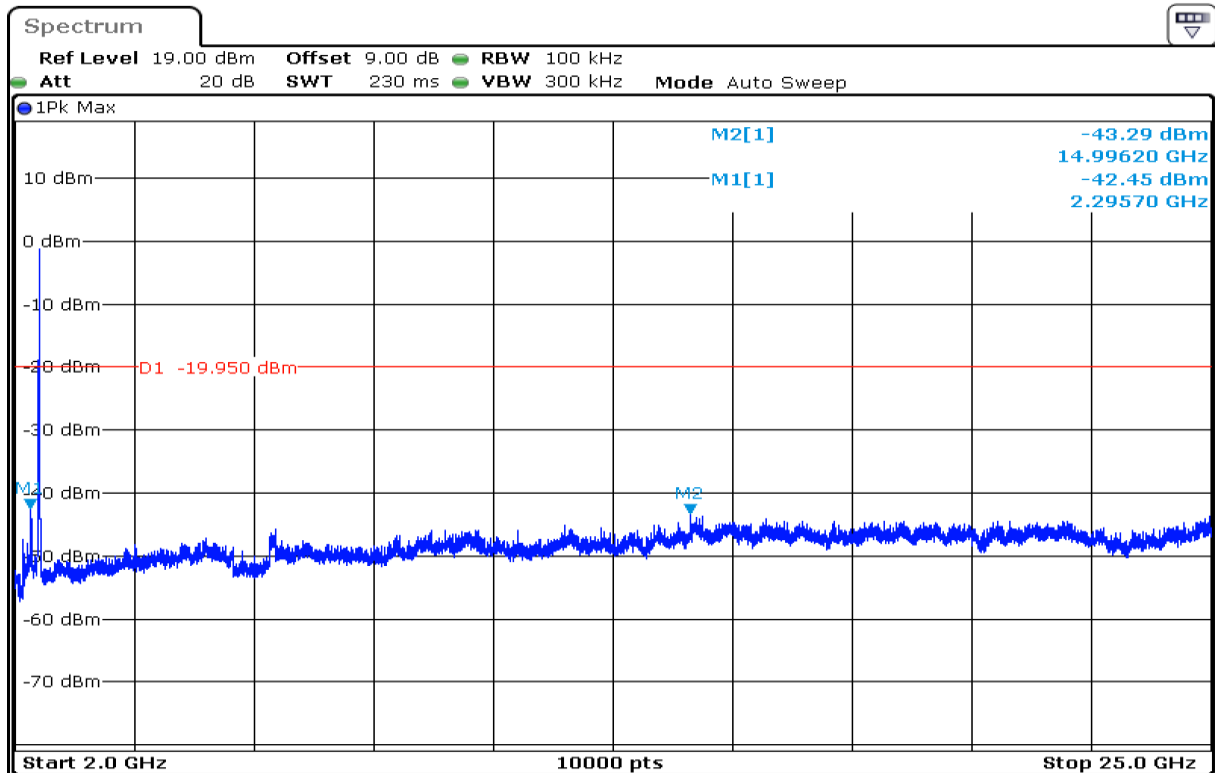
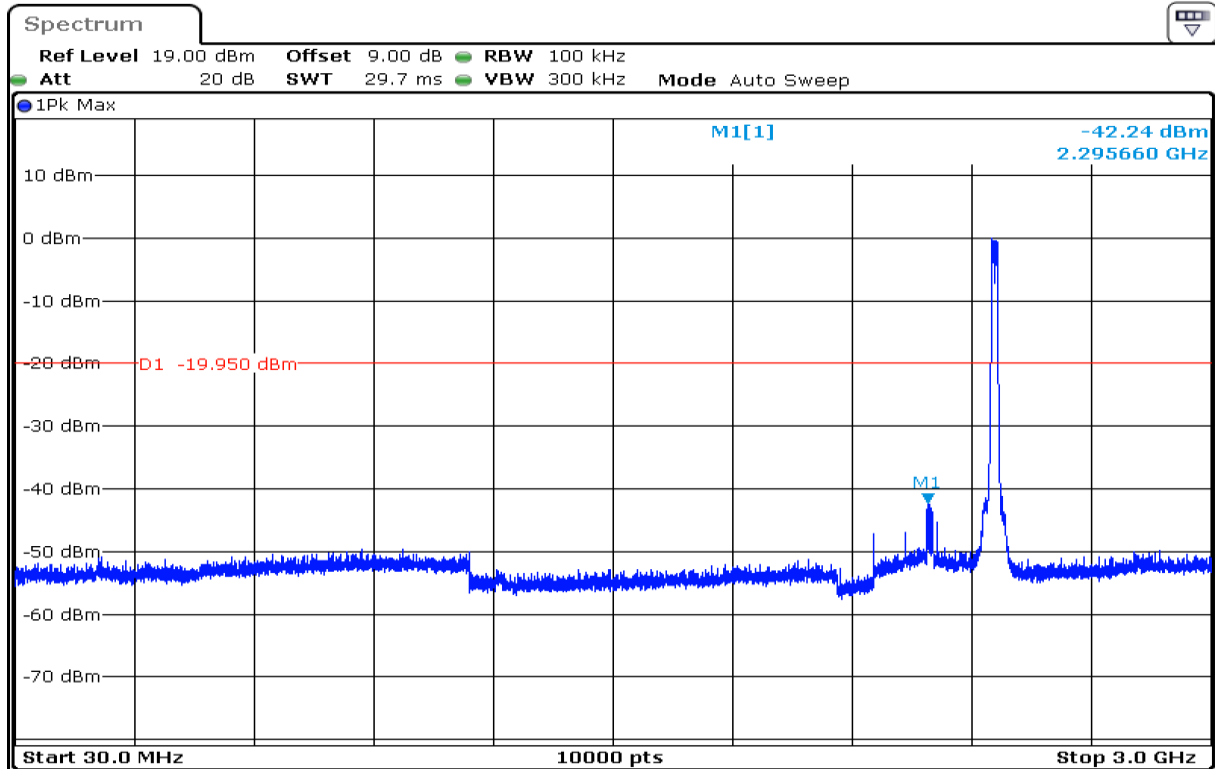

IEEE 802.11n HT20 mode CH Low

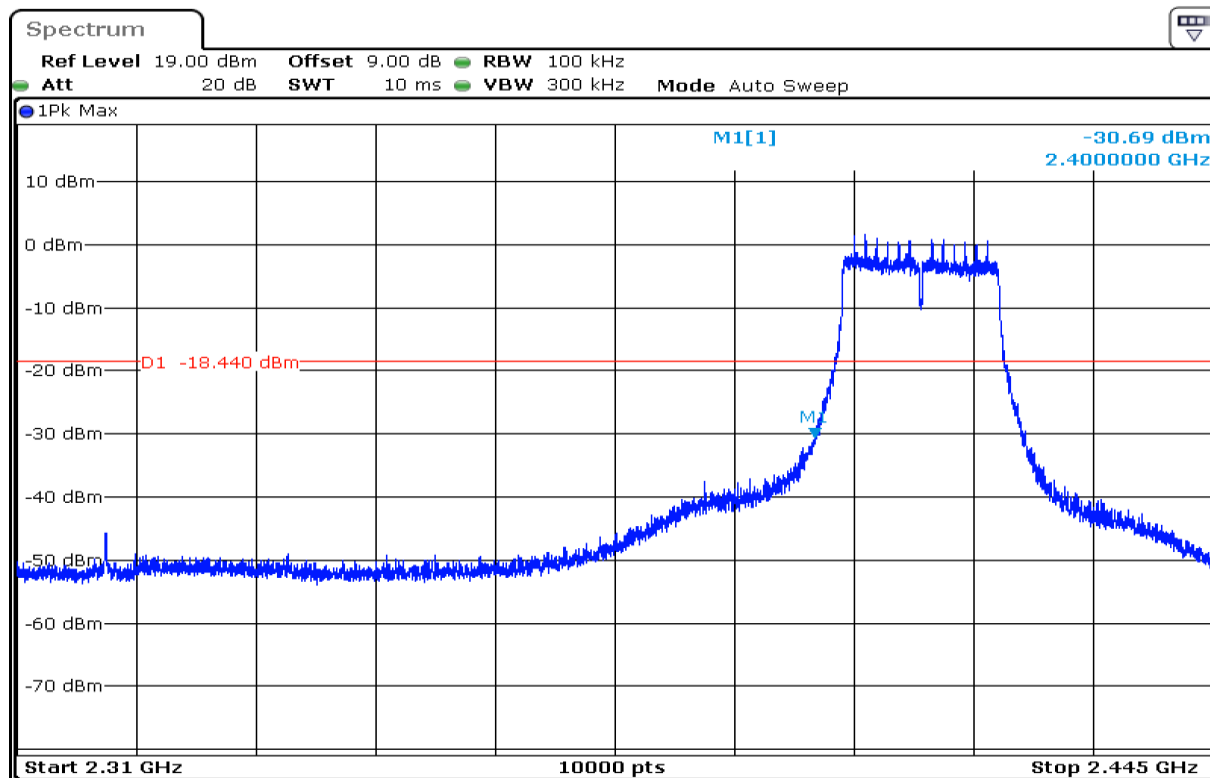
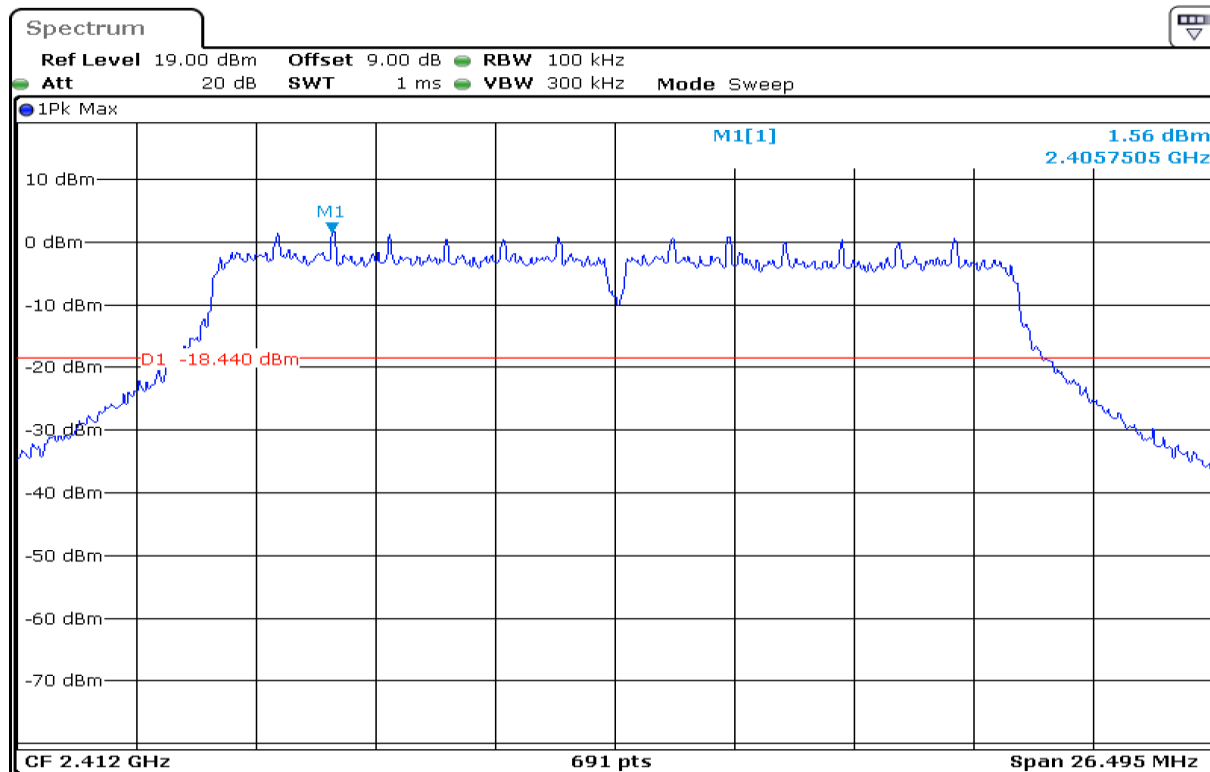

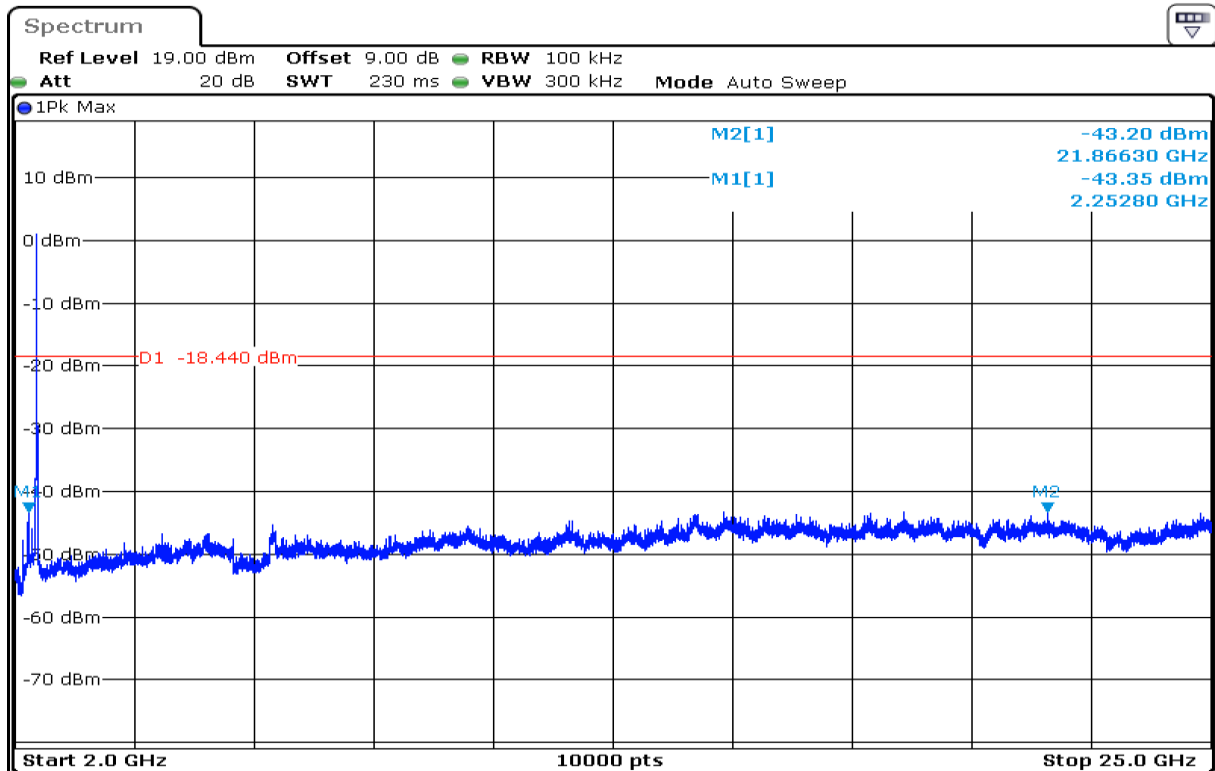
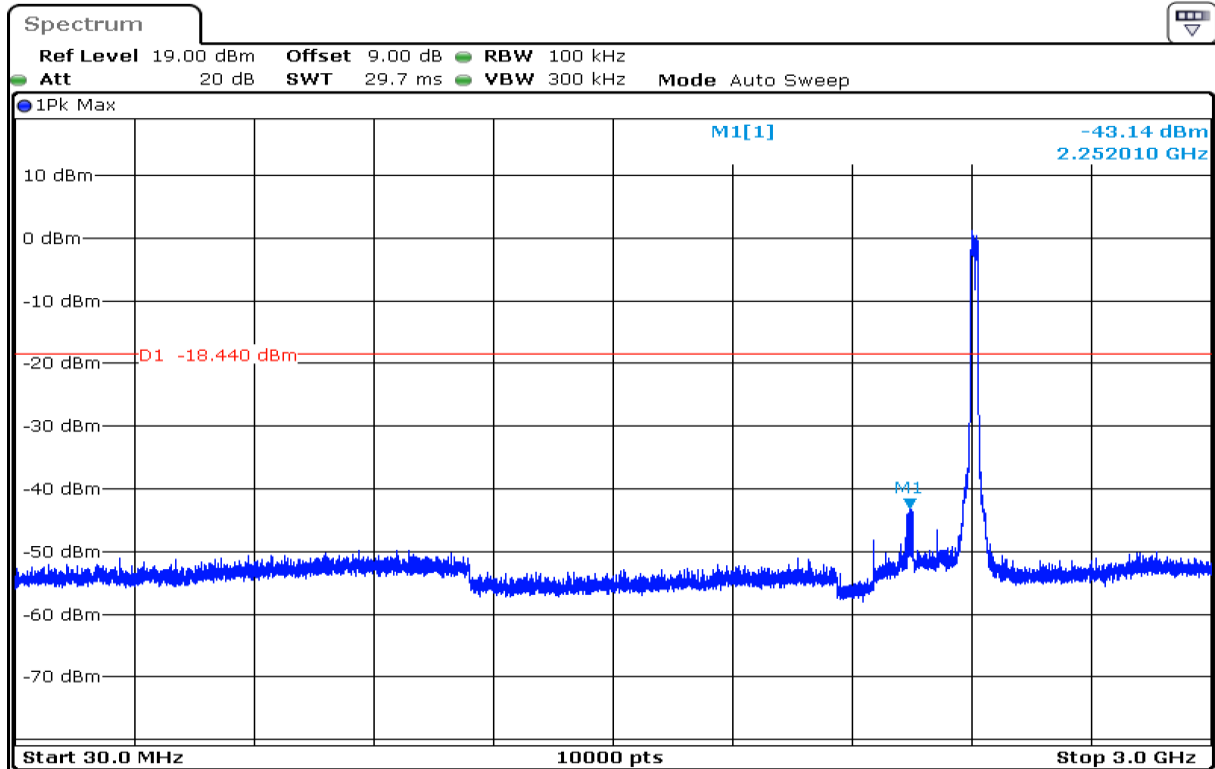

CH Mid

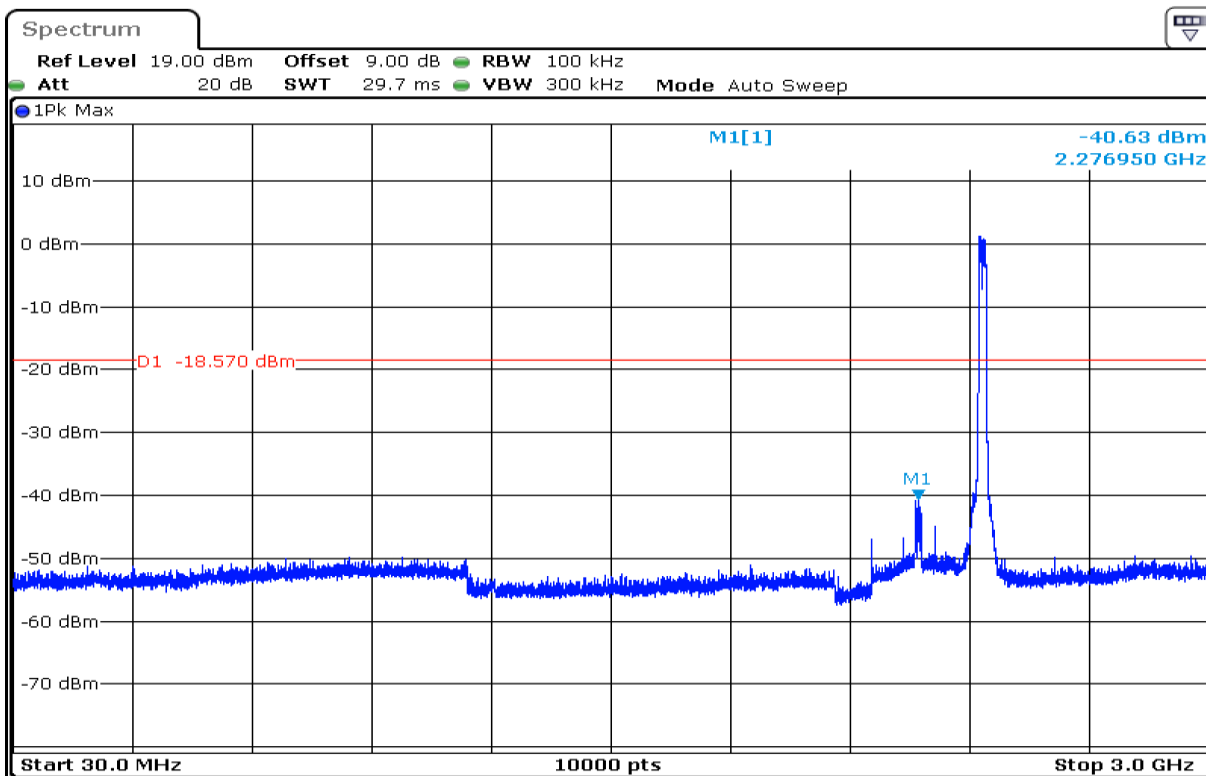
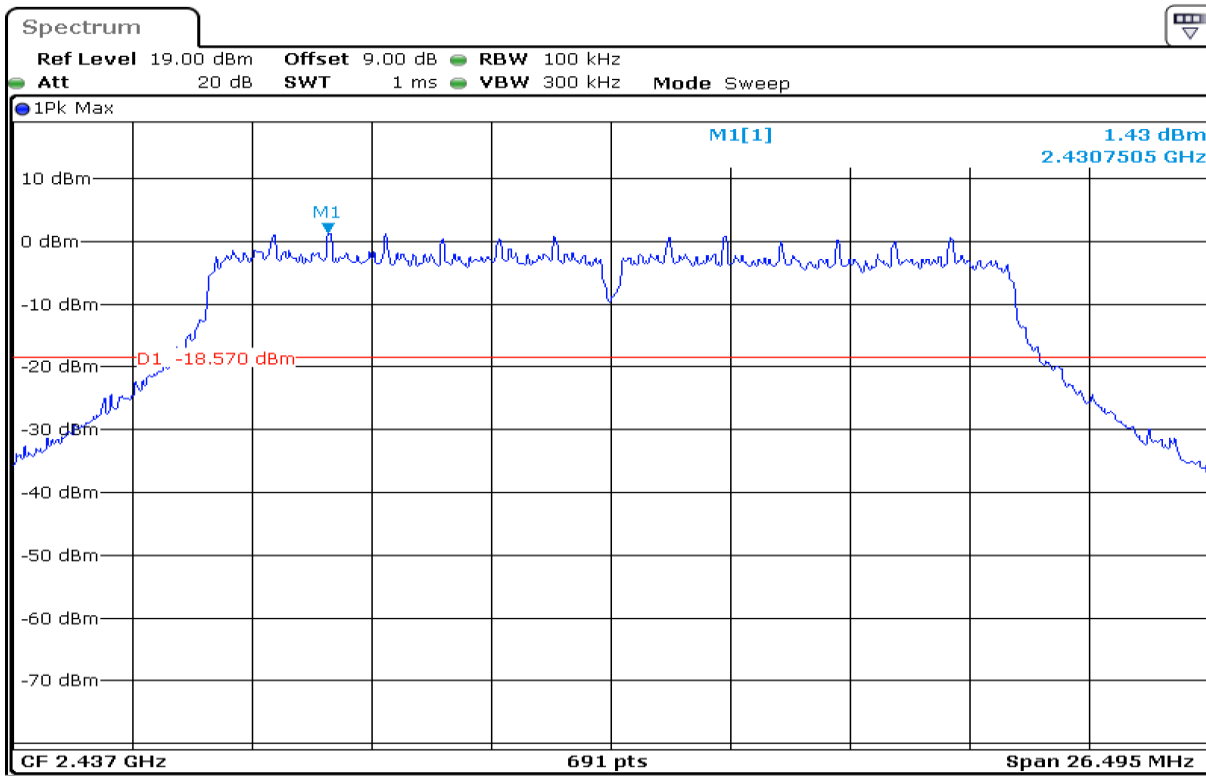

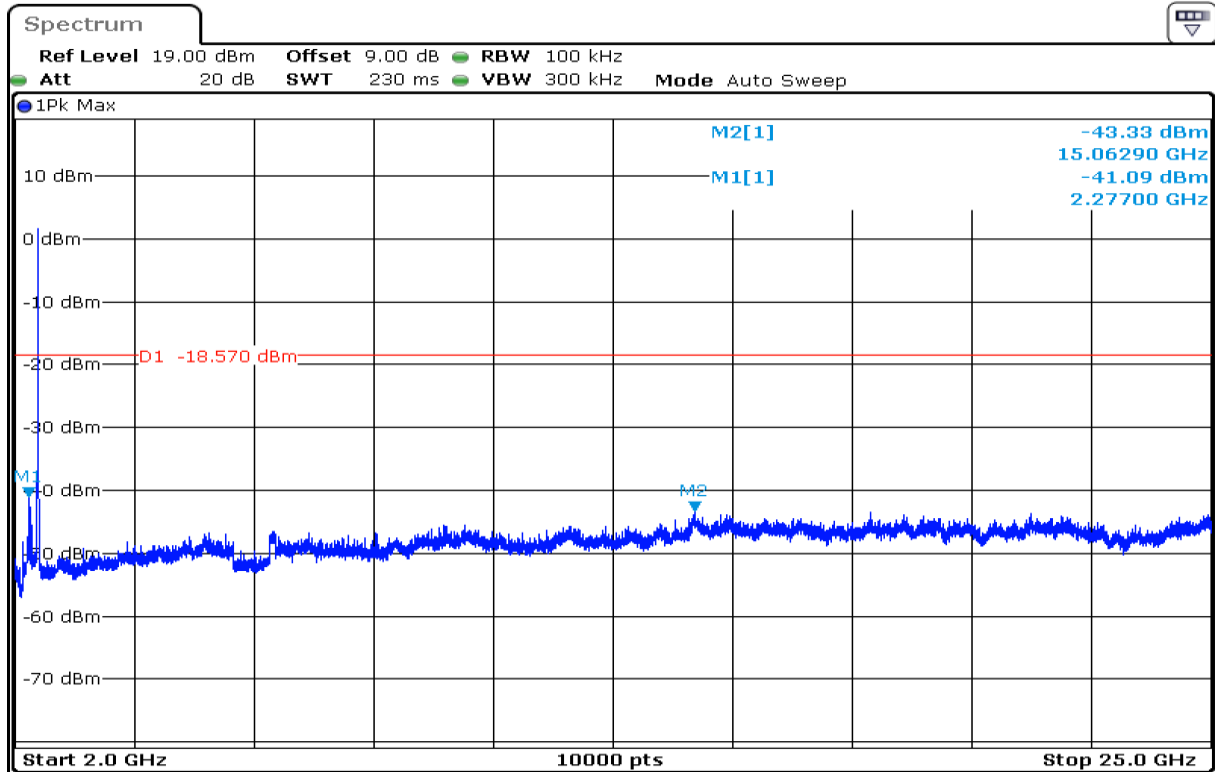

CH High

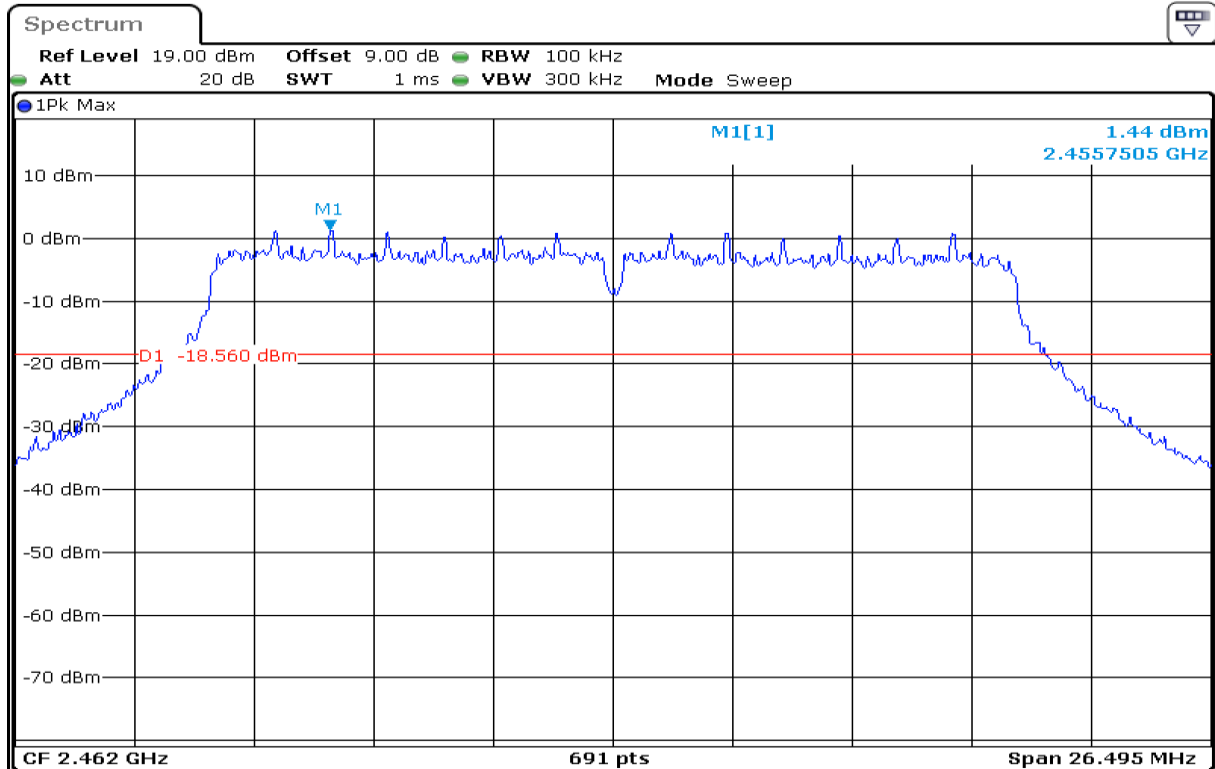

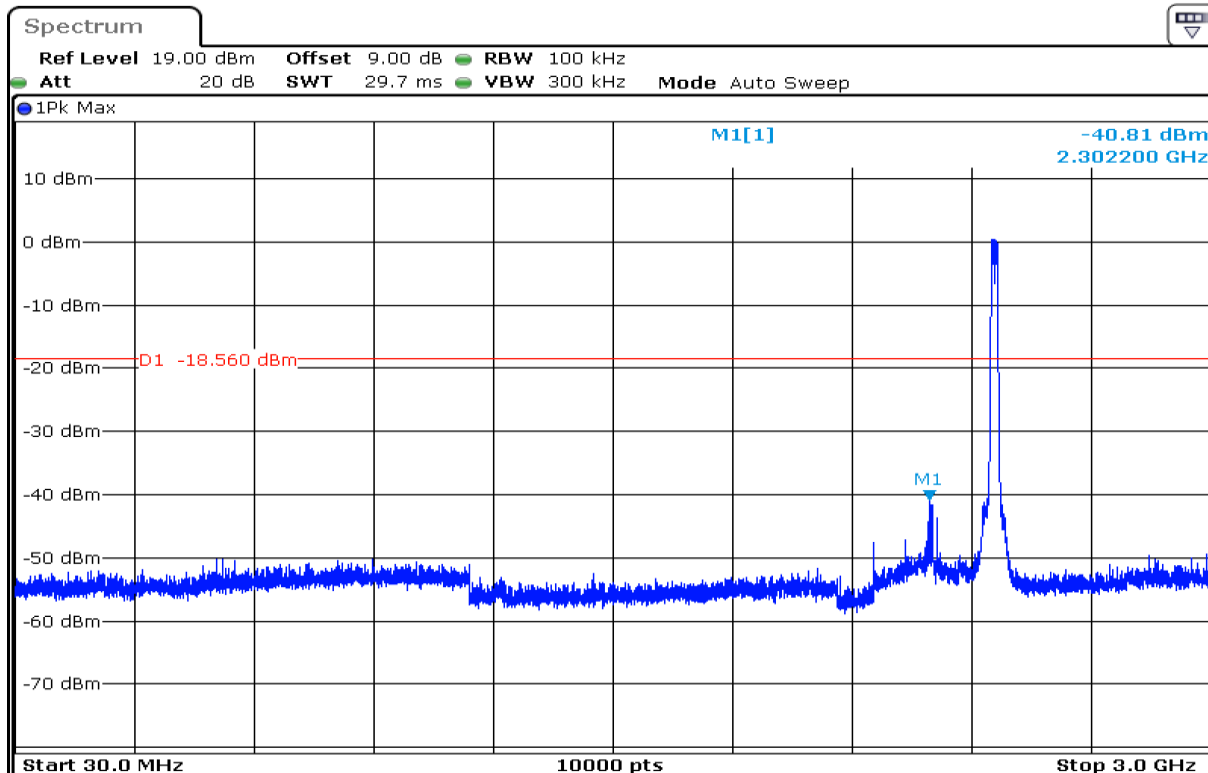
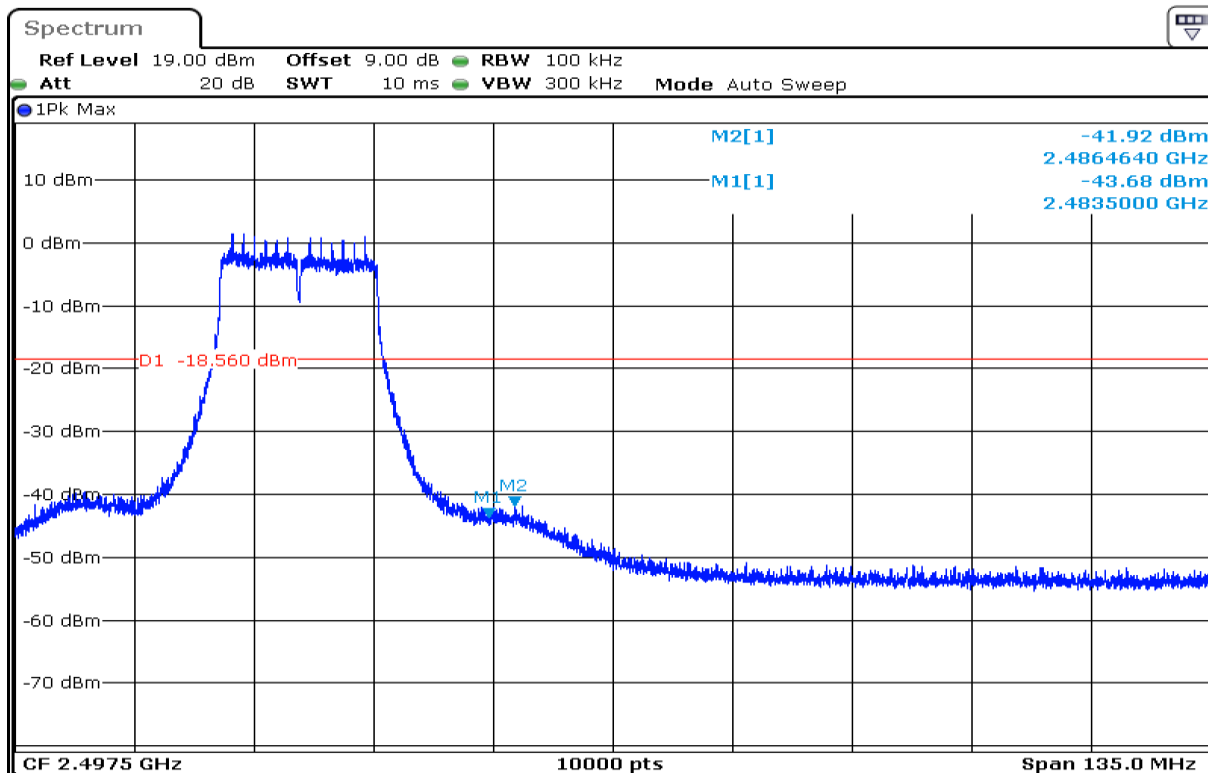

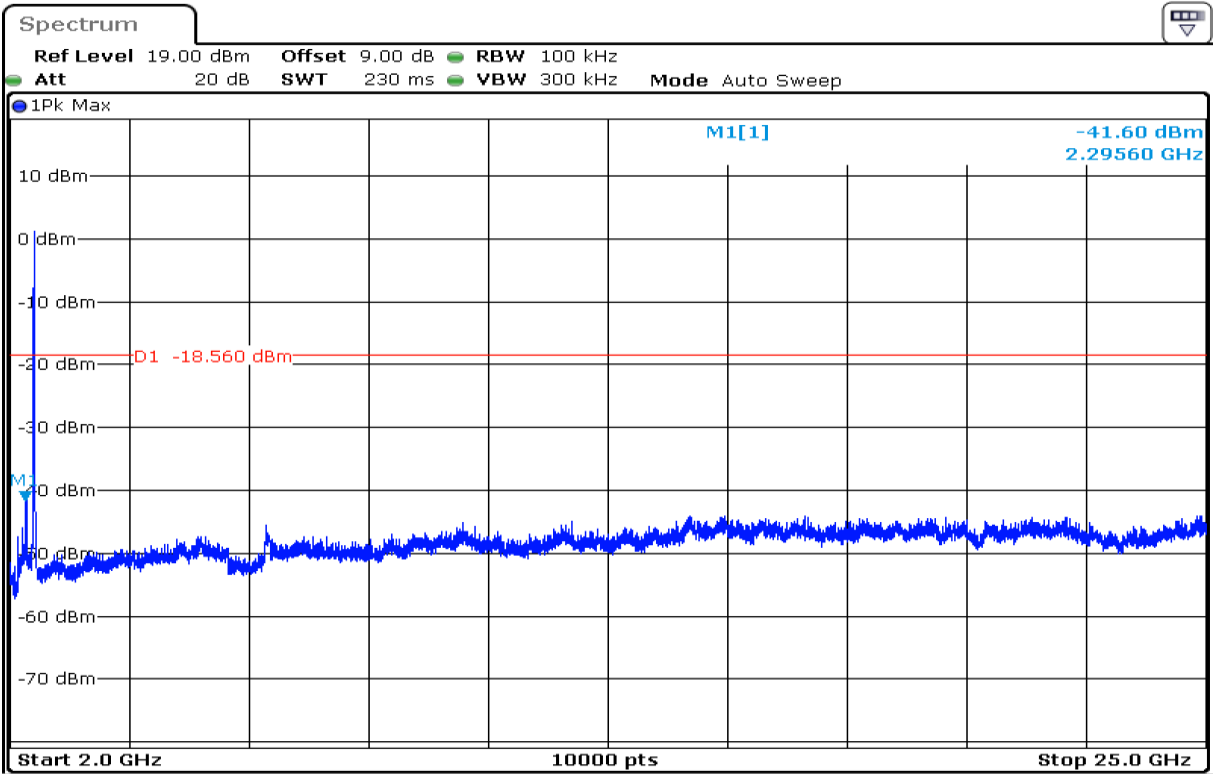

7.5. RADIATED EMISSIONS

LIMIT

Radiated emissions from 9 kHz to 25 GHz were measured according to the methods defines in ANSI C63.10-2013. The EUT was placed above the ground plane, 0.8 meter for frequency below 1GHz and 1.5 meter for frequency above 1GHz. The interface cables and equipment positions were varied within limits of reasonable applications to determine the positions producing maximum radiated emissions

1. According to §15.209(a), except as provided elsewhere in this Subpart, the emissions from an intentional radiator shall not exceed the field strength levels specified in the following table:

FREQUENCIES(MHz)	FIELD STRENGTH (microvolts/meter)	MEASUREMENT DISTANCE(meters)
0.009~0.490	2400/F(kHz)	300
0.490~1.705	24000/F(kHz)	30
1.705~30.0	30	30
30~88	100	3
88~216	150	3
216~960	200	3
Above 960	500	3

Remark: Except as provided in paragraph (g), fundamental emissions from intentional radiators operating under this Section shall not be located in the frequency bands 54-72 MHz, 76-88 MHz, 174-216 MHz or 470-806 MHz. However, operation within these frequency bands is permitted under other sections of this Part, e.g., Sections 15.231 and 15.241.

2. In the emission table above, the tighter limit applies at the band edges.

Frequency (MHz)	Field Strength (μ V/m at 3-meter)	Field Strength (dB μ V/m at 3-meter)
30-88	100	40
88-216	150	43.5
216-960	200	46
Above 960	500	54

Test Configuration

Below 30MHz

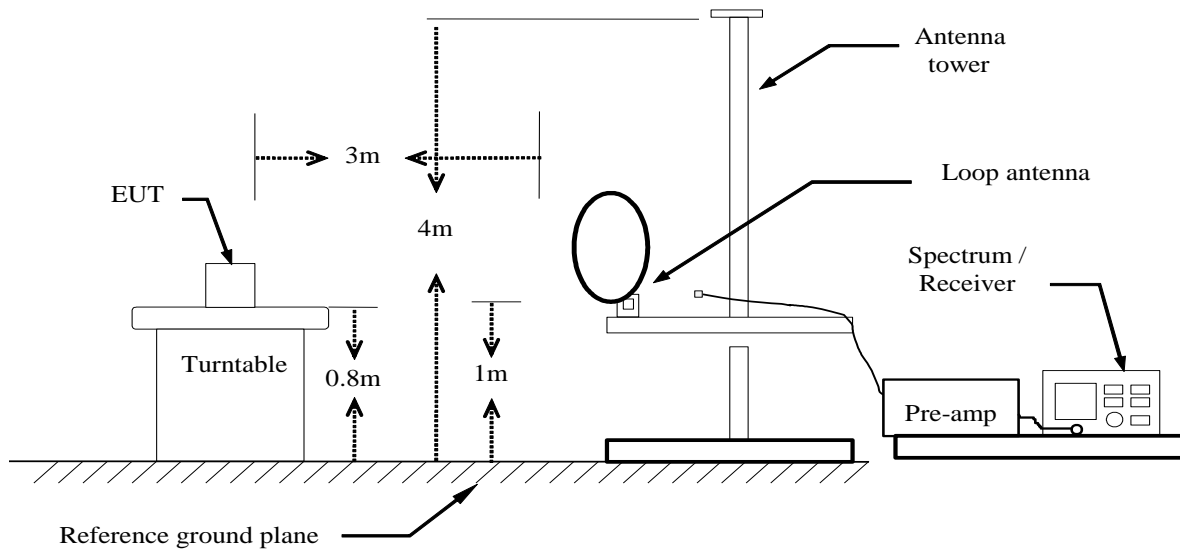

Below 1 GHz

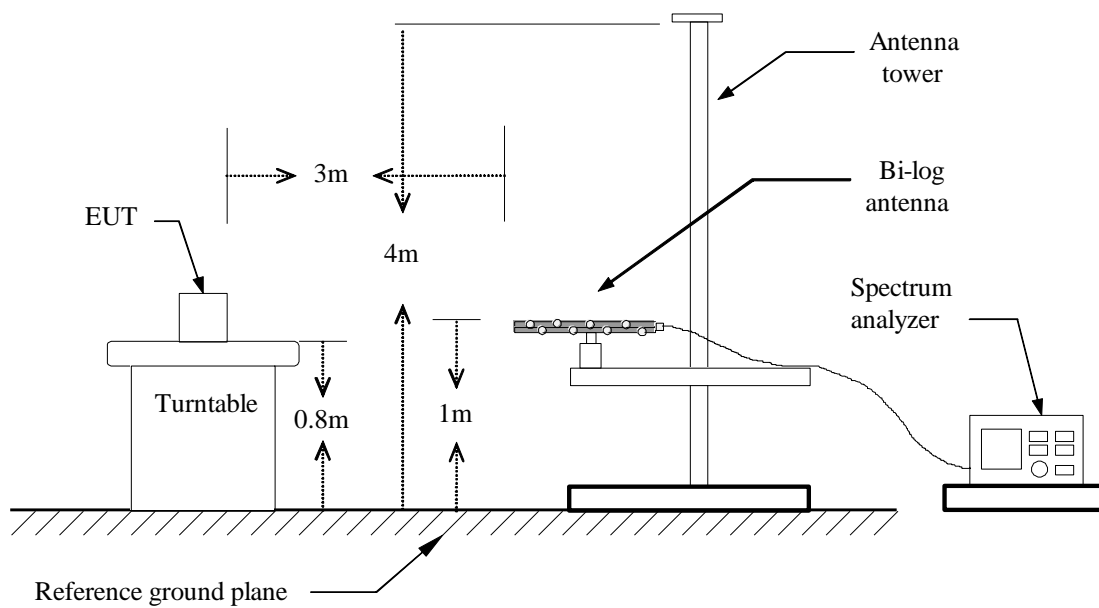

Above 1 GHz

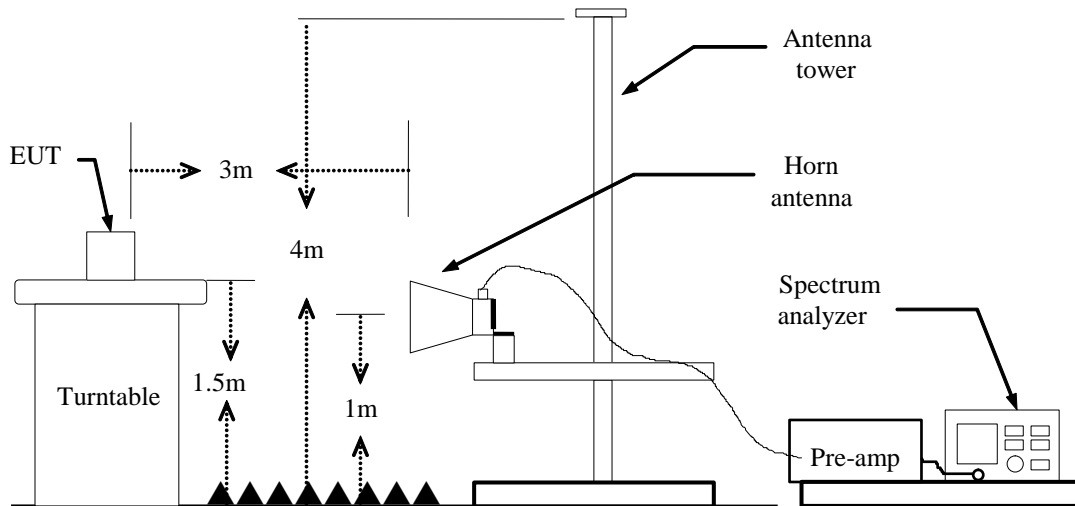

TEST PROCEDURE

1. The EUT is placed on a turntable above ground plane, which is 0.8 meter for frequency below 1GHz and 1.5 meter for frequency above 1GHz.
2. The turntable shall be rotated for 360 degrees to determine the position of maximum emission level.
3. EUT is set 3m away from the receiving antenna, which is varied from 1m to 4m to find out the highest emissions.
4. Maximum procedure was performed on the six highest emissions to ensure EUT compliance.
5. And also, each emission was to be maximized by changing the polarization of receiving antenna both horizontal and vertical.
6. Set the spectrum analyzer in the following setting as:

Below 1GHz:

RBW=100kHz / VBW=300kHz / Sweep=AUTO

Above 1GHz:

PEAK: RBW=VBW=1MHz / Sweep=AUTO

AVERAGE: RBW=1MHz / Sweep=AUTO

VBW=10Hz, when duty cycle is no less than 98 percent.

VBW $\geq 1/T$, when duty cycle is less than 98 percent, where T is the minimum transmission duration over which the transmitter is on and is transmitting at its maximum power control level for the tested mode of operation.

Band	Duty Cycle(%)	T(ms)	1/T(kHz)	VBW Setting
IEEE 802.11 b	100	-	-	10Hz
IEEE 802.11 g	97	1.399	0.715	1 KHz
IEEE 802.11n HT20	97	1.304	0.767	1 KHz

IEEE 802.11n HT20

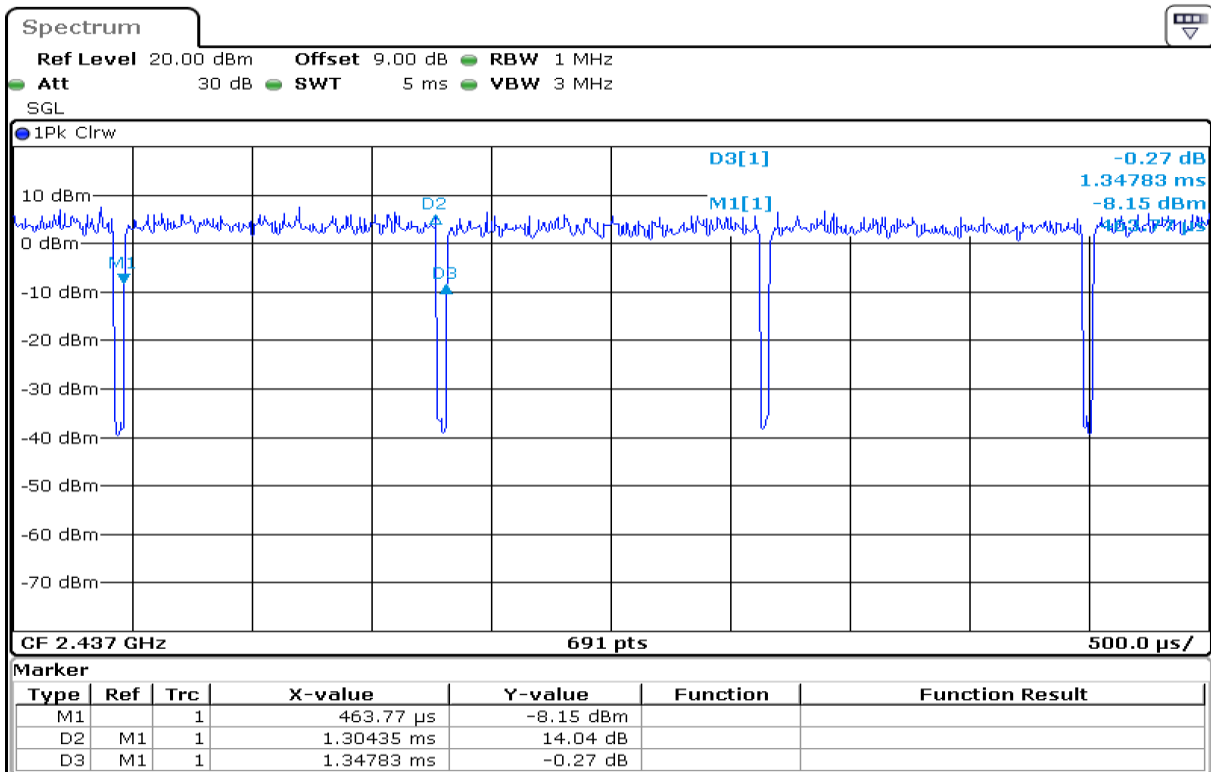

7. Repeat above procedures until the measurements for all frequencies are complete.

TEST RESULTS

RESTRICTED BANDEDGE (b Mode, Low Channel, Horizontal)

112.0 dBuV/m

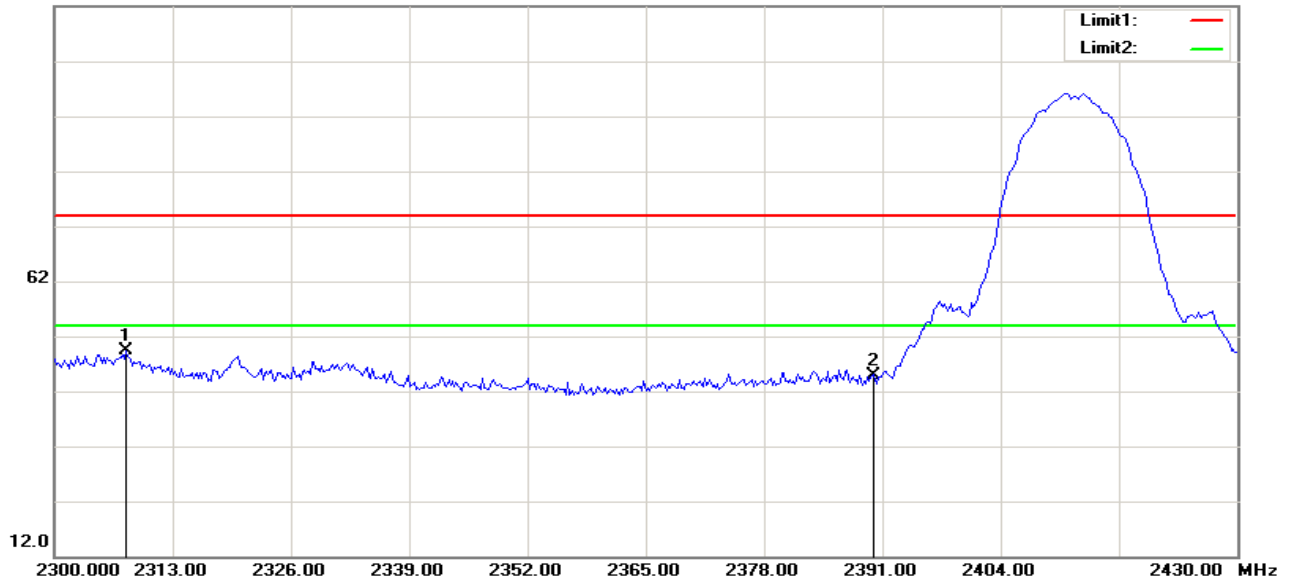

No.	Frequency (MHz)	Reading (dBuV)	Correct Factor(dB/m)	Result (dBuV/m)	Limit (dBuV/m)	Margin (dB)	Height (cm)	Degree (deg.)	Remark
1	2307.917	58.78	-9.47	49.31	74.00	-24.69	100	360	peak
2	2390.000	53.95	-8.95	45.00	74.00	-29.00	100	360	peak

RESTRICTED BANDEDGE (b Mode, Low Channel, Vertical)

112.0 dBuV/m

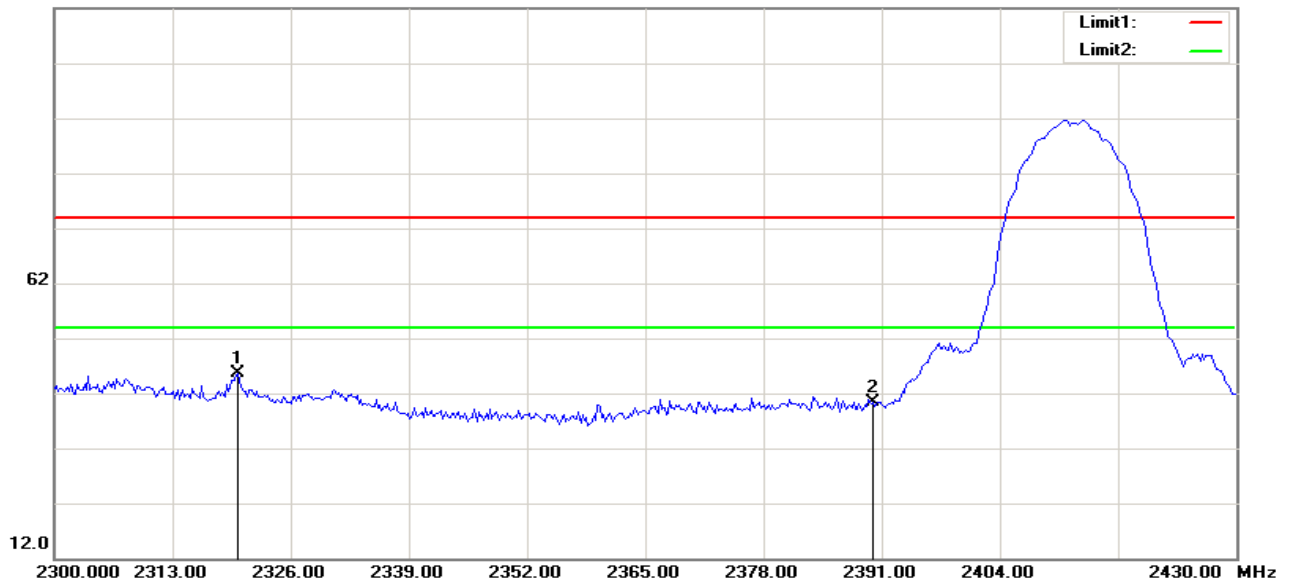

No.	Frequency (MHz)	Reading (dBuV)	Correct Factor(dB/m)	Result (dBuV/m)	Limit (dBuV/m)	Margin (dB)	Height (cm)	Degree (deg.)	Remark
1	2320.208	54.95	-9.39	45.56	74.00	-28.44	200	78	peak
2	2390.000	49.26	-8.95	40.31	74.00	-33.69	100	142	peak

RESTRICTED BANDEDGE (b Mode, High Channel, Horizontal)

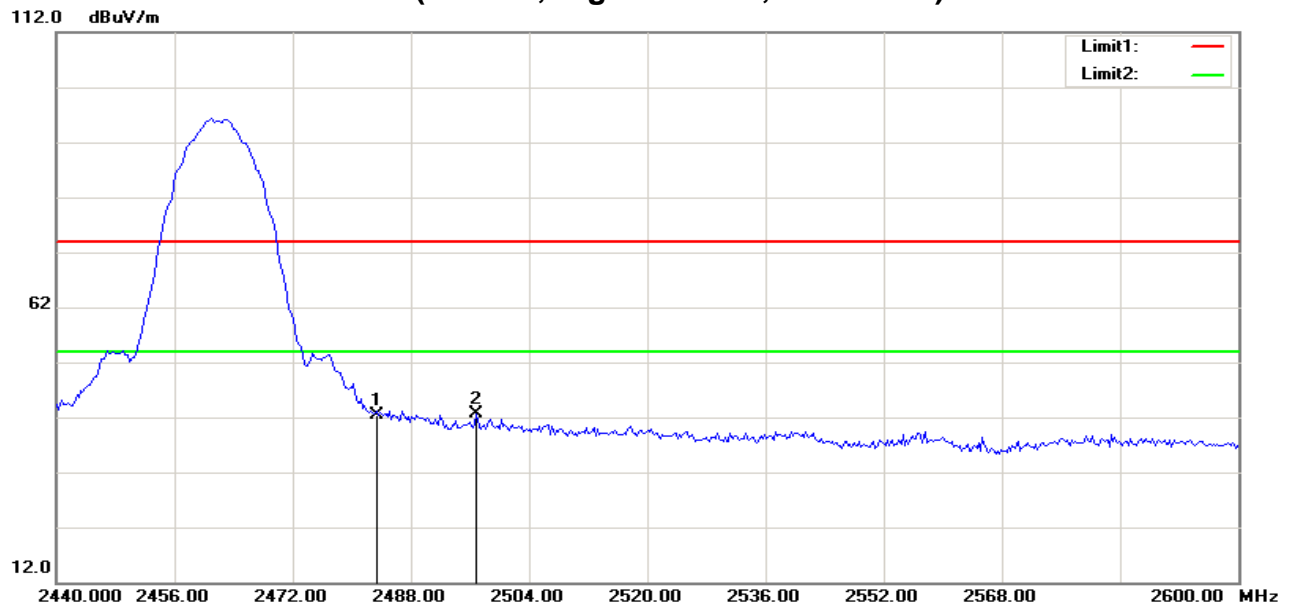

No.	Frequency (MHz)	Reading (dBuV)	Correct Factor(dB/m)	Result (dBuV/m)	Limit (dBuV/m)	Margin (dB)	Height (cm)	Degree (deg.)	Remark
1	2483.500	50.67	-8.35	42.32	74.00	-31.68	100	360	peak
2	2496.923	50.87	-8.26	42.61	74.00	-31.39	100	360	peak

RESTRICTED BANDEDGE (b Mode, High Channel, Vertical)

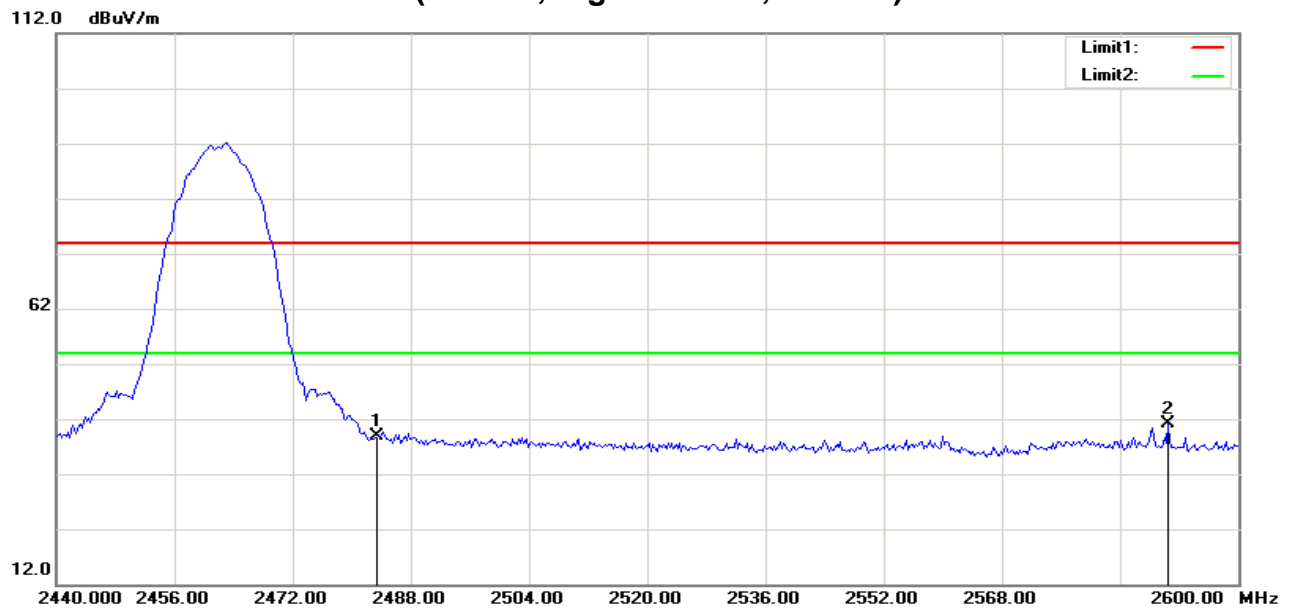

No.	Frequency (MHz)	Reading (dBuV)	Correct Factor(dB/m)	Result (dBuV/m)	Limit (dBuV/m)	Margin (dB)	Height (cm)	Degree (deg.)	Remark
1	2483.500	47.30	-8.35	38.95	74.00	-35.05	100	261	peak
2	2590.513	48.97	-7.79	41.18	74.00	-32.82	200	360	peak

RESTRICTED BANDEDGE (g Mode, Low Channel, Horizontal)

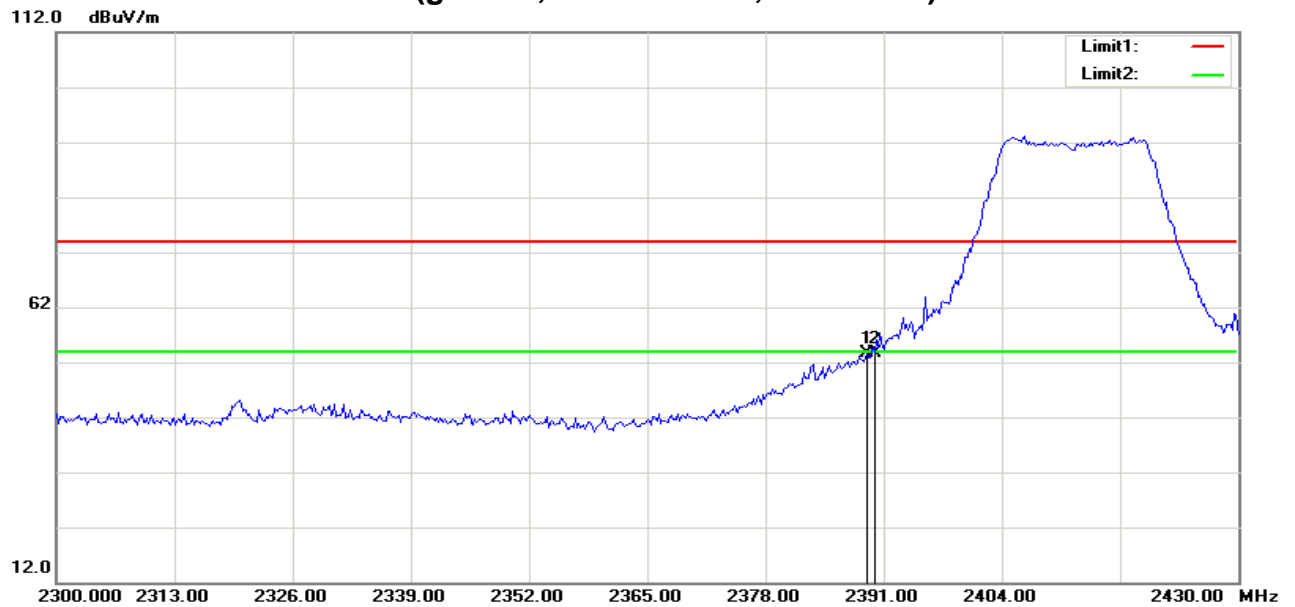

No.	Frequency (MHz)	Reading (dBuV)	Correct Factor(dB/m)	Result (dBuV/m)	Limit (dBuV/m)	Margin (dB)	Height (cm)	Degree (deg.)	Remark
1	2389.167	62.65	-8.95	53.70	74.00	-20.30	100	360	peak
2	2390.000	62.60	-8.95	53.65	74.00	-20.35	100	324	peak

RESTRICTED BANDEDGE (g Mode, Low Channel, Vertical)

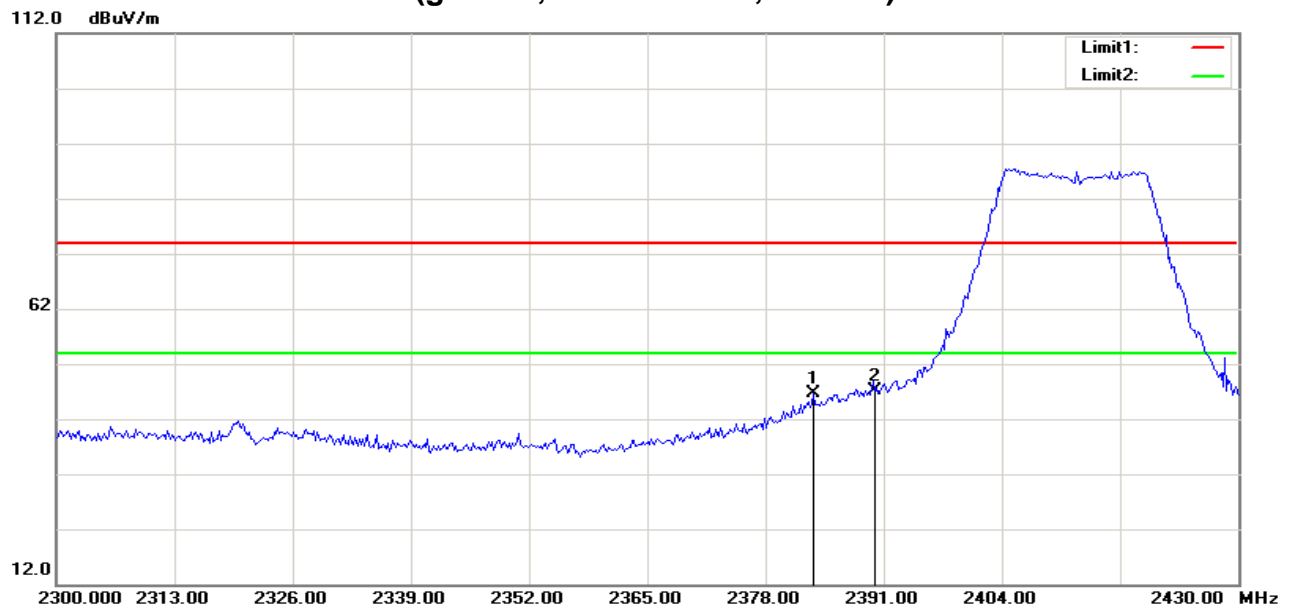

No.	Frequency (MHz)	Reading (dBuV)	Correct Factor(dB/m)	Result (dBuV/m)	Limit (dBuV/m)	Margin (dB)	Height (cm)	Degree (deg.)	Remark
1	2383.333	55.61	-8.99	46.62	74.00	-27.38	200	213	peak
2	2390.000	56.06	-8.95	47.11	74.00	-26.89	100	213	peak

RESTRICTED BANDEDGE (g Mode, High Channel, Horizontal)

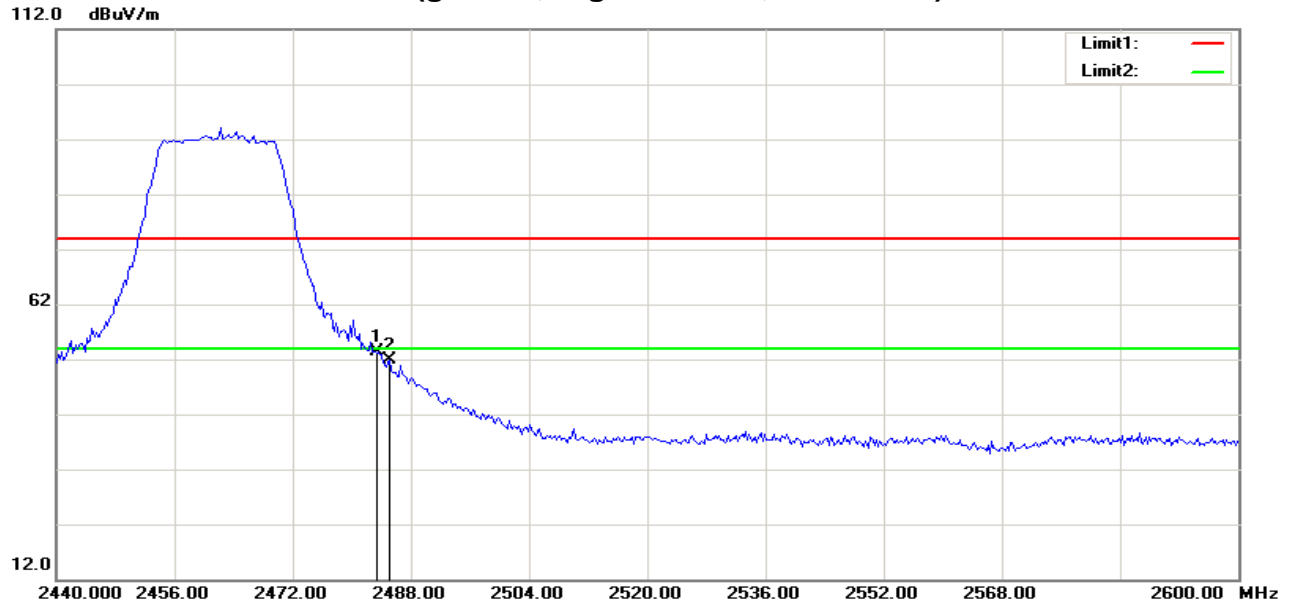

No.	Frequency (MHz)	Reading (dBuV)	Correct Factor(dB/m)	Result (dBuV/m)	Limit (dBuV/m)	Margin (dB)	Height (cm)	Degree (deg.)	Remark
1	2483.500	61.84	-8.35	53.49	74.00	-20.51	100	360	peak
2	2485.128	60.15	-8.34	51.81	74.00	-22.19	200	360	peak

RESTRICTED BANDEDGE (g Mode, High Channel, Vertical)

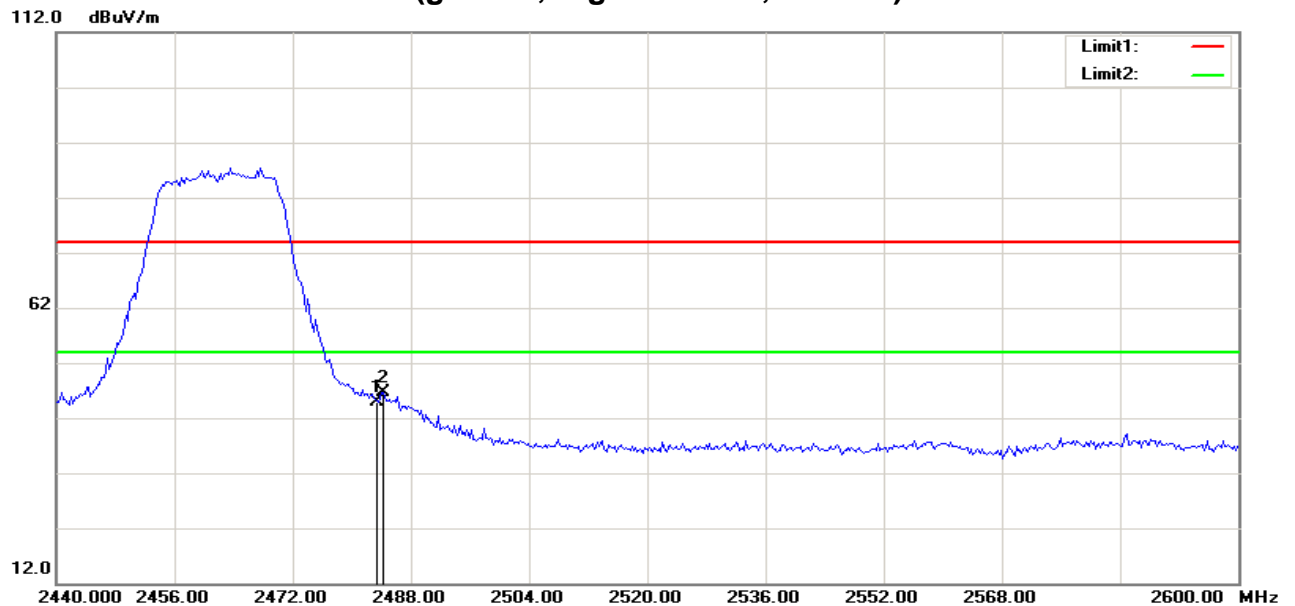

No.	Frequency (MHz)	Reading (dBuV)	Correct Factor(dB/m)	Result (dBuV/m)	Limit (dBuV/m)	Margin (dB)	Height (cm)	Degree (deg.)	Remark
1	2483.500	53.26	-8.35	44.91	74.00	-29.09	100	103	peak
2	2484.359	55.03	-8.34	46.69	74.00	-27.31	200	90	peak

RESTRICTED BANDEDGE (IEEE 802.11n HT20 mode, Low Channel, Horizontal)

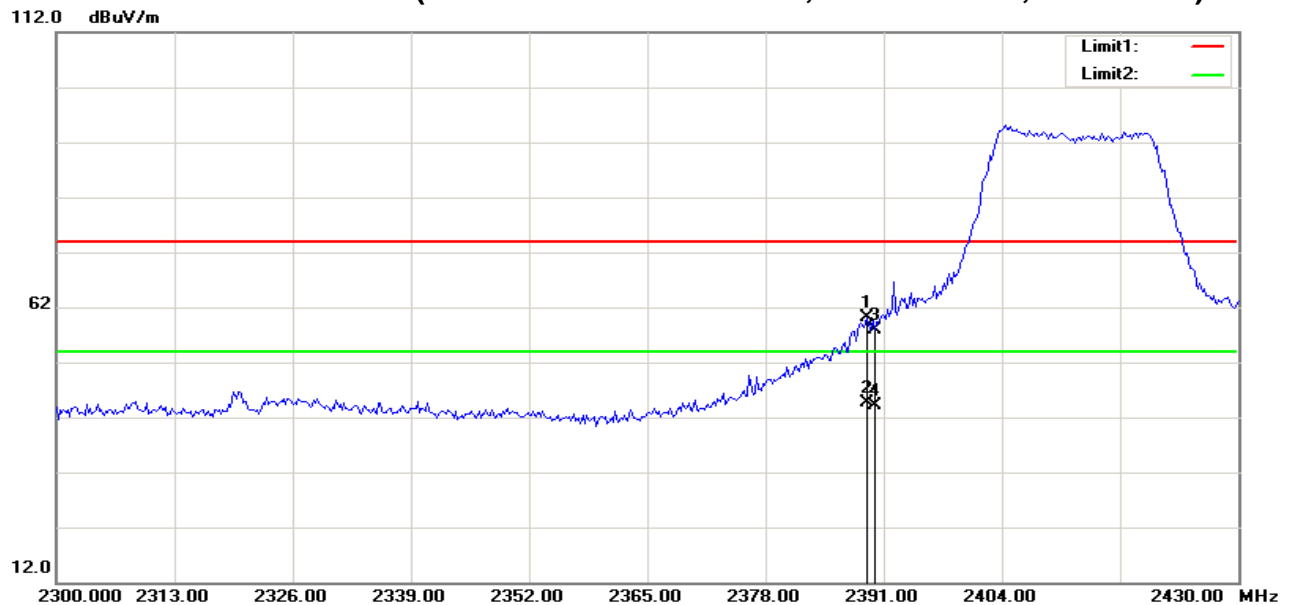

No.	Frequency (MHz)	Reading (dBuV)	Correct Factor(dB/m)	Result (dBuV/m)	Limit (dBuV/m)	Margin (dB)	Height (cm)	Degree (deg.)	Remark
1	2389.167	69.18	-8.95	60.23	74.00	-13.77	200	360	peak
2	2389.167	53.64	-8.95	44.69	54.00	-9.31	200	360	AVG
3	2390.000	66.87	-8.95	57.92	74.00	-16.08	200	360	peak
4	2390.000	53.20	-8.95	44.25	54.00	-9.75	200	360	AVG

RESTRICTED BANDEDGE (IEEE 802.11n HT20 mode, Low Channel, Vertical)

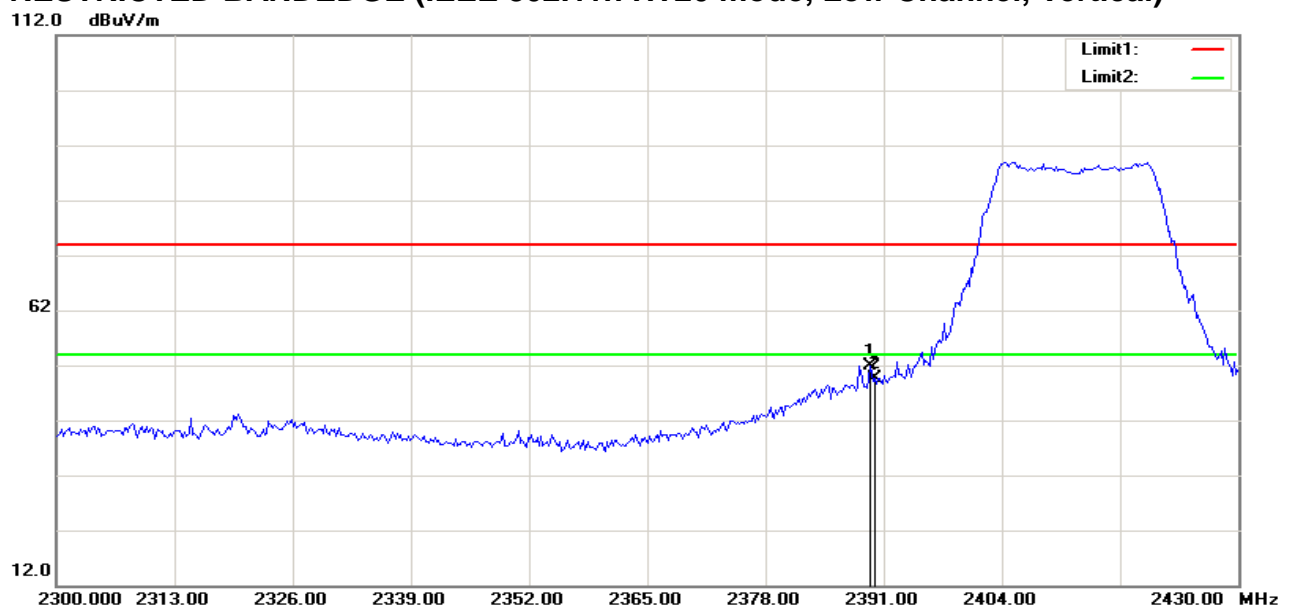

No.	Frequency (MHz)	Reading (dBuV)	Correct Factor(dB/m)	Result (dBuV/m)	Limit (dBuV/m)	Margin (dB)	Height (cm)	Degree (deg.)	Remark
1	2389.583	60.92	-8.95	51.97	74.00	-22.03	100	121	peak
2	2390.000	58.58	-8.95	49.63	74.00	-24.37	100	117	peak

RESTRICTED BANDEDGE (IEEE 802.11n HT20 mode, High Channel, Horizontal)

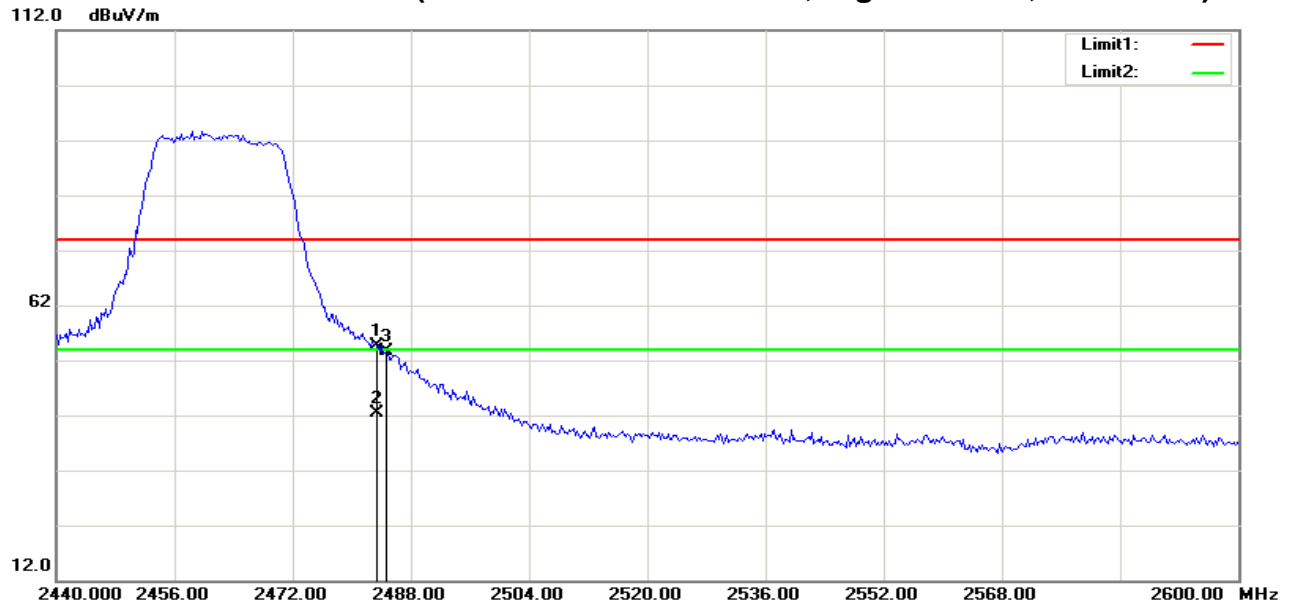

No.	Frequency (MHz)	Reading (dBuV)	Correct Factor(dB/m)	Result (dBuV/m)	Limit (dBuV/m)	Margin (dB)	Height (cm)	Degree (deg.)	Remark
1	2483.500	62.91	-8.35	54.56	74.00	-19.44	200	360	peak
2	2483.500	50.85	-8.35	42.50	54.00	-11.50	200	360	AVG
3	2484.615	62.02	-8.34	53.68	74.00	-20.32	100	0	peak

RESTRICTED BANDEDGE (IEEE 802.11n HT20 mode, High Channel, Vertical)

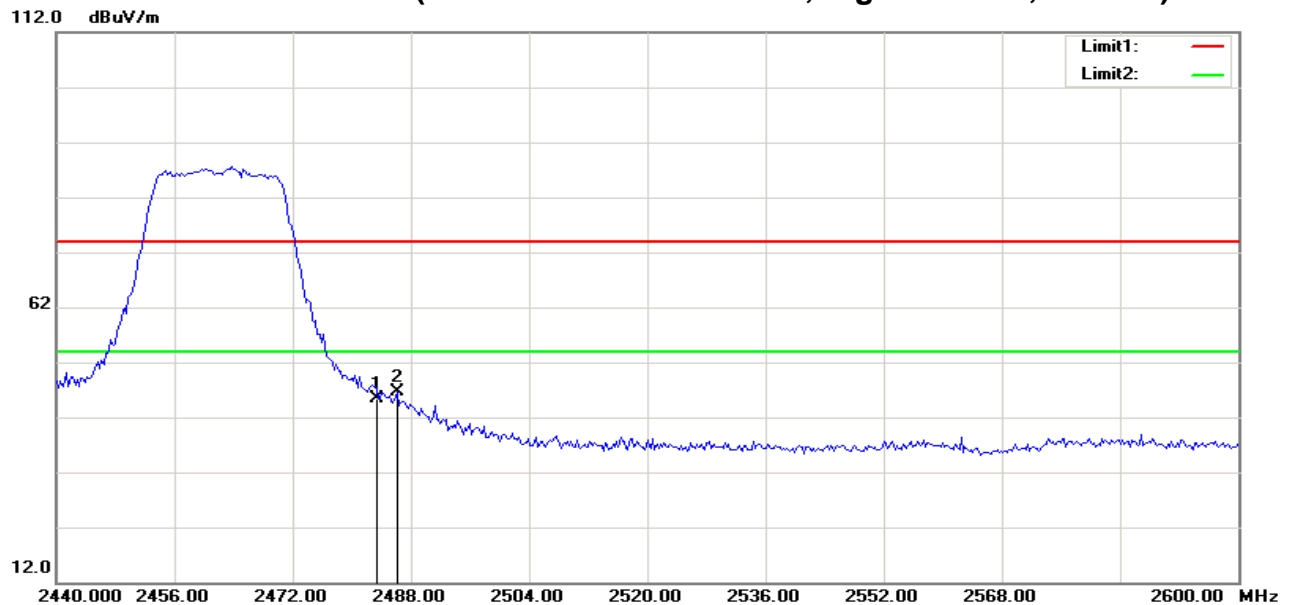

No.	Frequency (MHz)	Reading (dBuV)	Correct Factor(dB/m)	Result (dBuV/m)	Limit (dBuV/m)	Margin (dB)	Height (cm)	Degree (deg.)	Remark
1	2483.500	53.70	-8.35	45.35	74.00	-28.65	100	123	peak
2	2486.154	54.97	-8.33	46.64	74.00	-27.36	200	111	peak

Test Result of Radiated Emission

Below 30MHz and above 18GHz. The measured value have enough margin over 20dB than the limit, therefore they are not reported.

30MHz-1GHz

Operation Mode:	IEEE 802.11b / CH Mid	Test Date:	January 15, 2019
Temperature:	25°C	Tested by:	Tim.cao
Humidity:	51% RH	Polarity:	Hor.

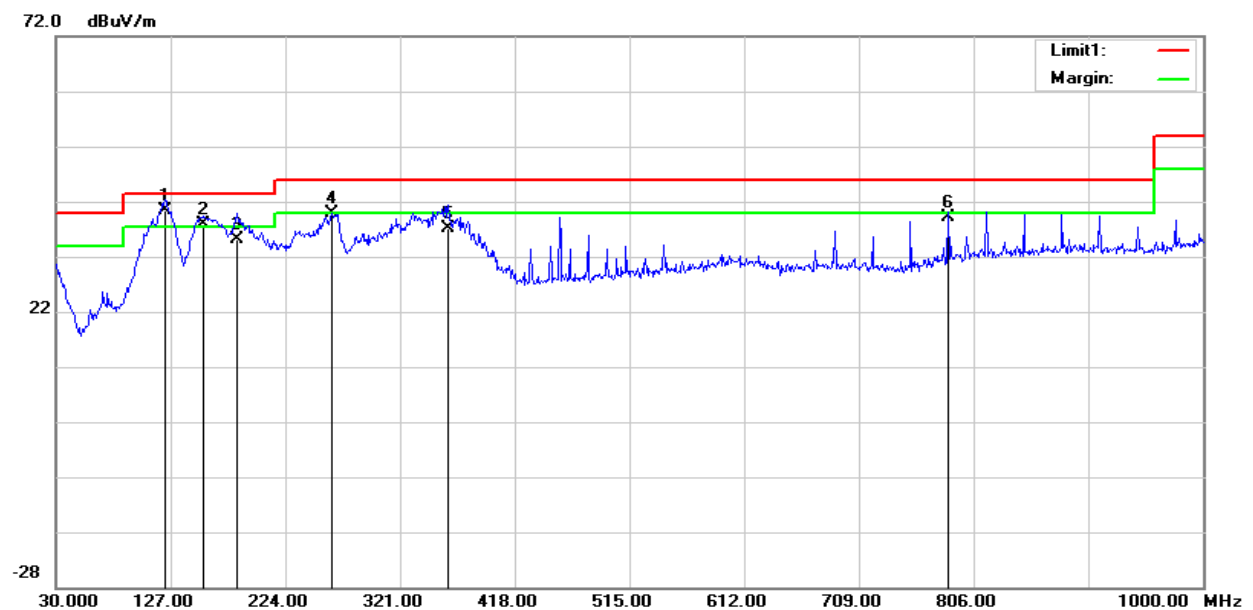

No.	Frequency (MHz)	Reading (dBuV)	Correct Factor(dB/m)	Result (dBuV/m)	Limit (dBuV/m)	Margin (dB)	Height (cm)	Degree (deg.)	Remark
1	122.1500	22.37	17.89	40.26	43.50	-3.24	300	300	QP
2	154.1600	20.08	17.78	37.86	43.50	-5.64	200	0	QP
3	183.2600	17.83	17.39	35.22	43.50	-8.28	100	82	QP
4	263.7700	20.74	19.06	39.80	46.00	-6.20	100	82	peak
5	361.7400	11.34	25.74	37.08	46.00	-8.92	100	52	QP
6	784.6600	12.11	26.90	39.01	46.00	-6.99	100	0	QP

Operation Mode:	IEEE 802.11b / CH Mid	Test Date:	January 15, 2019
Temperature:	25°C	Tested by:	Tim.cao
Humidity:	51% RH	Polarity:	Ver.

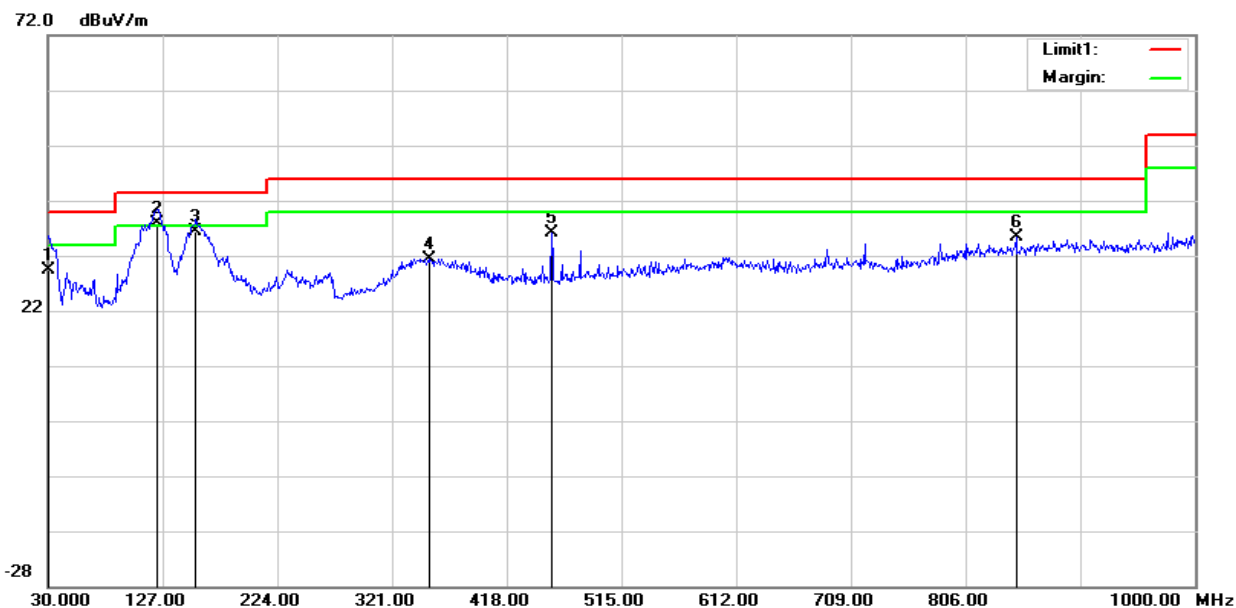

No.	Frequency (MHz)	Reading (dBuV)	Correct Factor(dB/m)	Result (dBuV/m)	Limit (dBuV/m)	Margin (dB)	Height (cm)	Degree (deg.)	Remark
1	30.0000	3.53	25.76	29.29	40.00	-10.71	100	0	QP
2	122.1500	20.06	17.89	37.95	43.50	-5.55	100	0	QP
3	155.1300	18.55	17.77	36.32	43.50	-7.18	100	360	QP
4	352.0400	5.29	26.20	31.49	46.00	-14.51	100	124	peak
5	455.8300	12.42	23.65	36.07	46.00	-9.93	200	52	peak
6	848.6800	7.04	28.46	35.50	46.00	-10.50	200	80	peak

Remark:

1. Measuring frequencies from 30 MHz to the 1GHz (No emission found between lowest internal used/generated frequency to 30 MHz).
2. Radiated emissions measured in frequency range from 30 MHz to 1000MHz were made with an instrument using peak/quasi-peak detector mode.
3. Measurements above show only up to 6 maximum emissions noted, or would be lesser, with " N/A " remark, if no specific emissions from the EUT are recorded (ie: margin>20dB from the applicable limit) and considered that's already beyond the background noise floor.
4. Margin (dB) = Result (dBuV/m) – Limit (dBuV/m).

Above 1 GHz

Operation Mode: TX / IEEE 802.11b / CH Low

Temperature: 25°C

Humidity: 51% RH

Test Date: 2018-10-16

Tested by: Tim.cao

Polarity: Ver. / Hor.

Horizontal

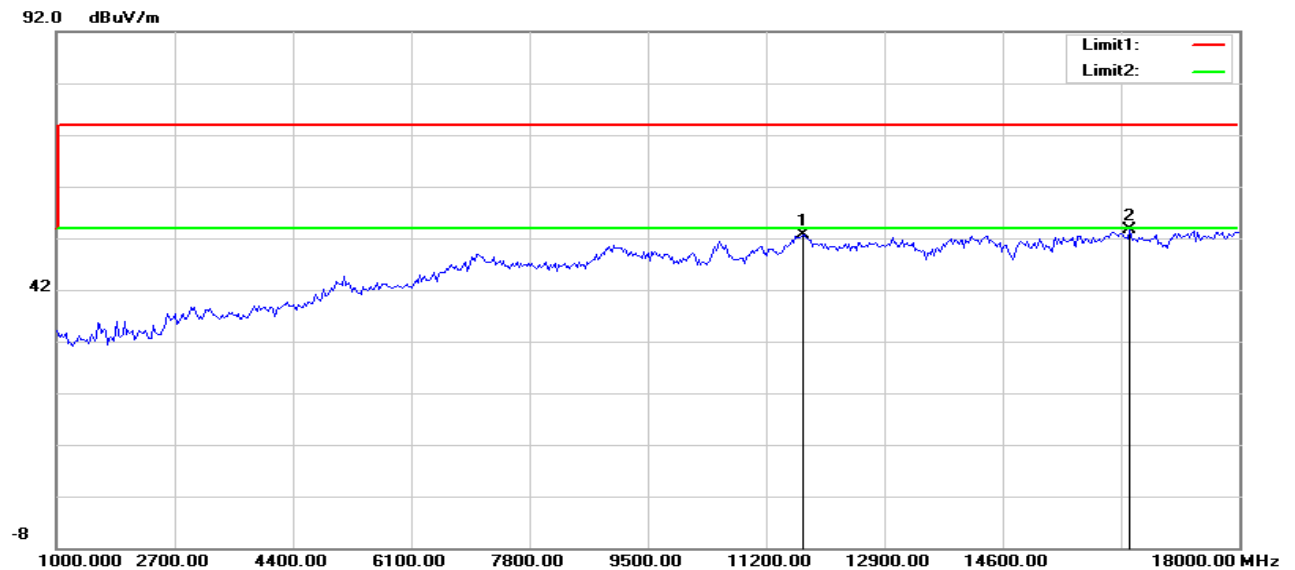

No.	Frequency (MHz)	Reading (dBuV)	Correct Factor(dB/m)	Result (dBuV/m)	Limit (dBuV/m)	Margin (dB)	Height (cm)	Degree (deg.)	Remark
1	11733.974	40.95	11.69	52.64	74.00	-21.36	170	360	peak
2	16419.872	39.19	14.44	53.63	74.00	-20.37	200	246	peak

Vertical

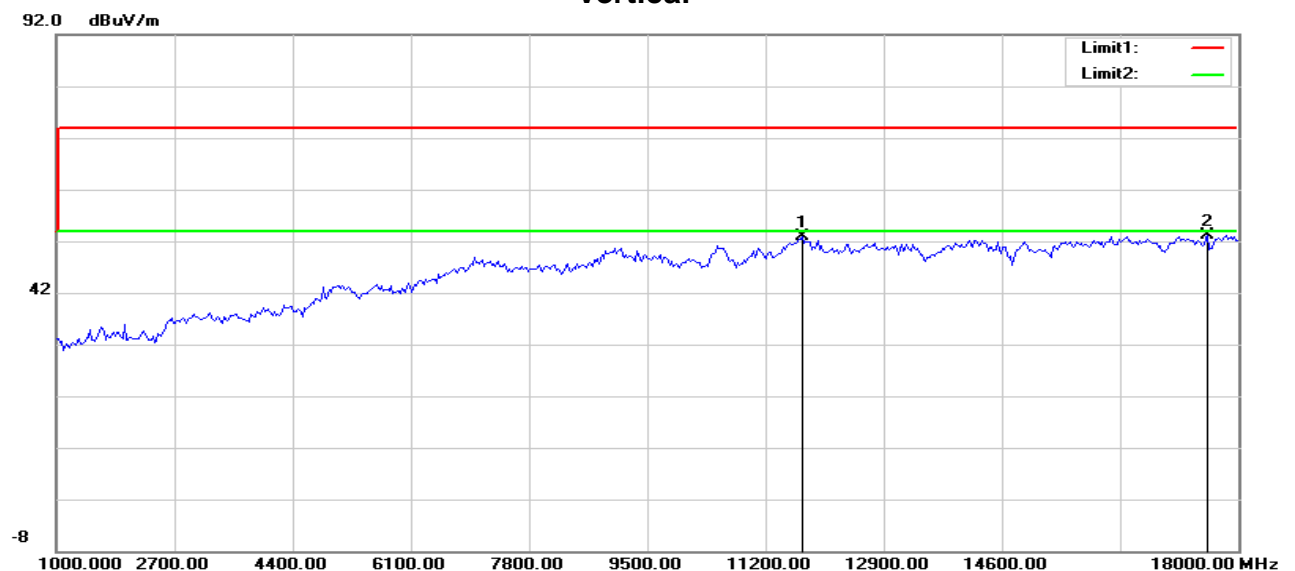

No.	Frequency (MHz)	Reading (dBuV)	Correct Factor(dB/m)	Result (dBuV/m)	Limit (dBuV/m)	Margin (dB)	Height (cm)	Degree (deg.)	Remark
1	11733.974	41.23	11.69	52.92	74.00	-21.08	100	360	peak
2	17564.103	35.48	17.68	53.16	74.00	-20.84	200	145	peak

Operation Mode: TX / IEEE 802.11b / CH Mid

Test Date: 2018-10-16

Temperature: 25°C

Tested by: Tim.cao

Humidity: 51% RH

Polarity: Ver. / Hor.

Horizontal

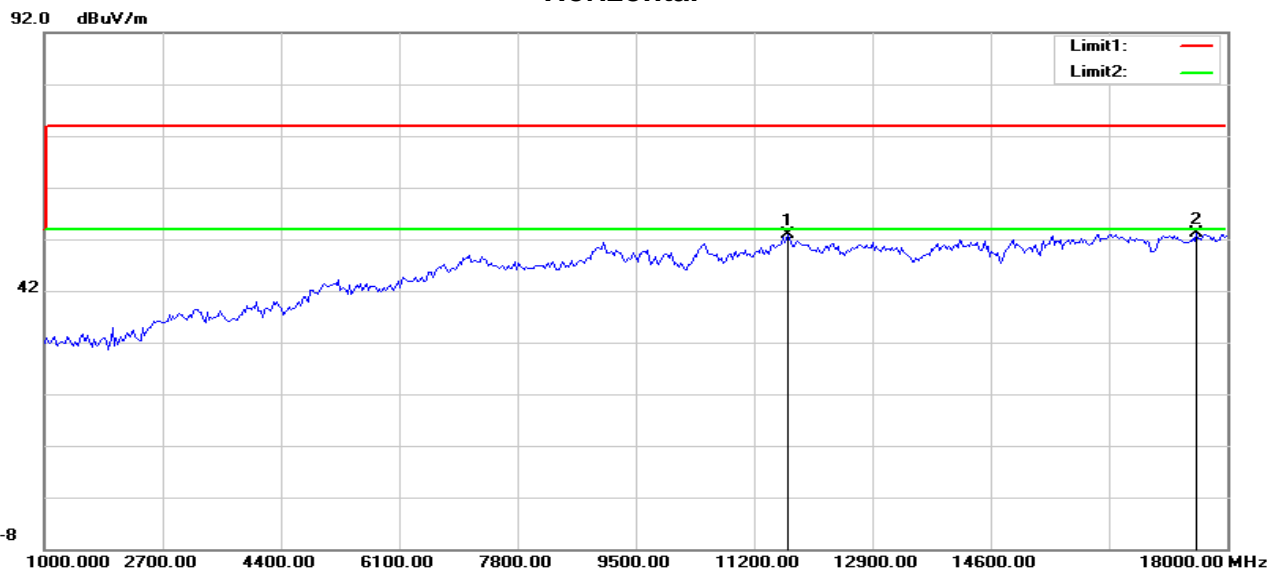

No.	Frequency (MHz)	Reading (dBuV)	Correct Factor(dB/m)	Result (dBuV/m)	Limit (dBuV/m)	Margin (dB)	Height (cm)	Degree (deg.)	Remark
1	11679.487	41.28	11.60	52.88	74.00	-21.12	100	19	peak
2	17564.103	35.35	17.68	53.03	74.00	-20.97	100	162	peak

Vertical

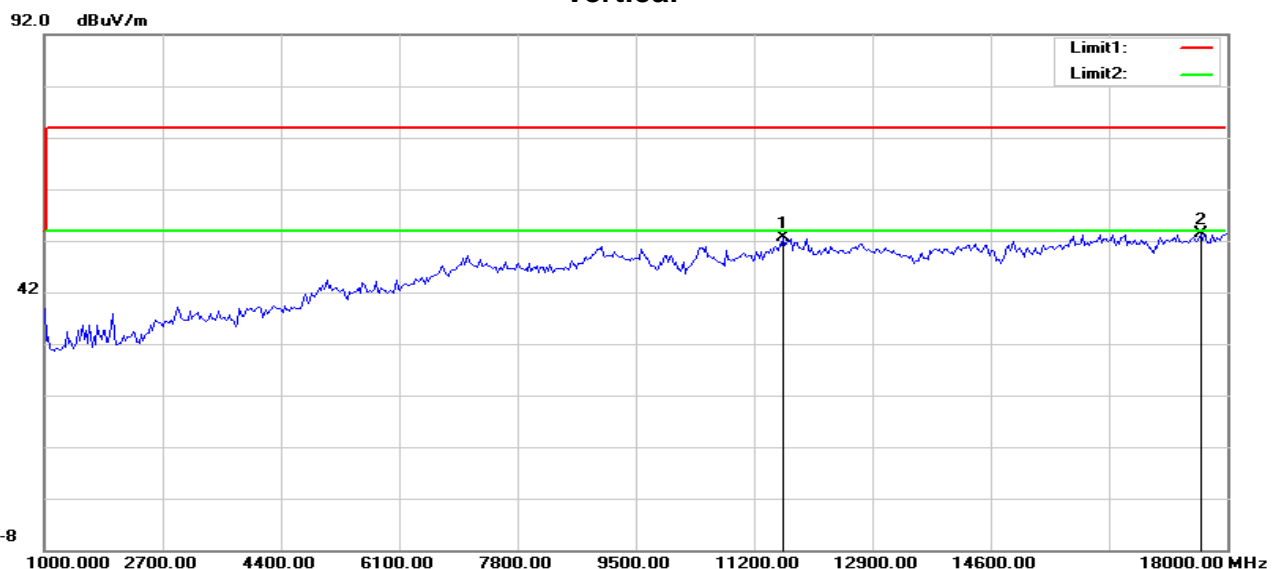

No.	Frequency (MHz)	Reading (dBuV)	Correct Factor(dB/m)	Result (dBuV/m)	Limit (dBuV/m)	Margin (dB)	Height (cm)	Degree (deg.)	Remark
1	11625.000	41.01	11.50	52.51	74.00	-21.49	100	360	peak
2	17618.590	35.68	17.73	53.41	74.00	-20.59	100	272	peak

Operation Mode: TX / IEEE 802.11b / CH High

Test Date: 2018-10-16

Temperature: 25°C

Tested by: Tim.cao

Humidity: 51% RH

Polarity: Ver. / Hor.

Horizontal

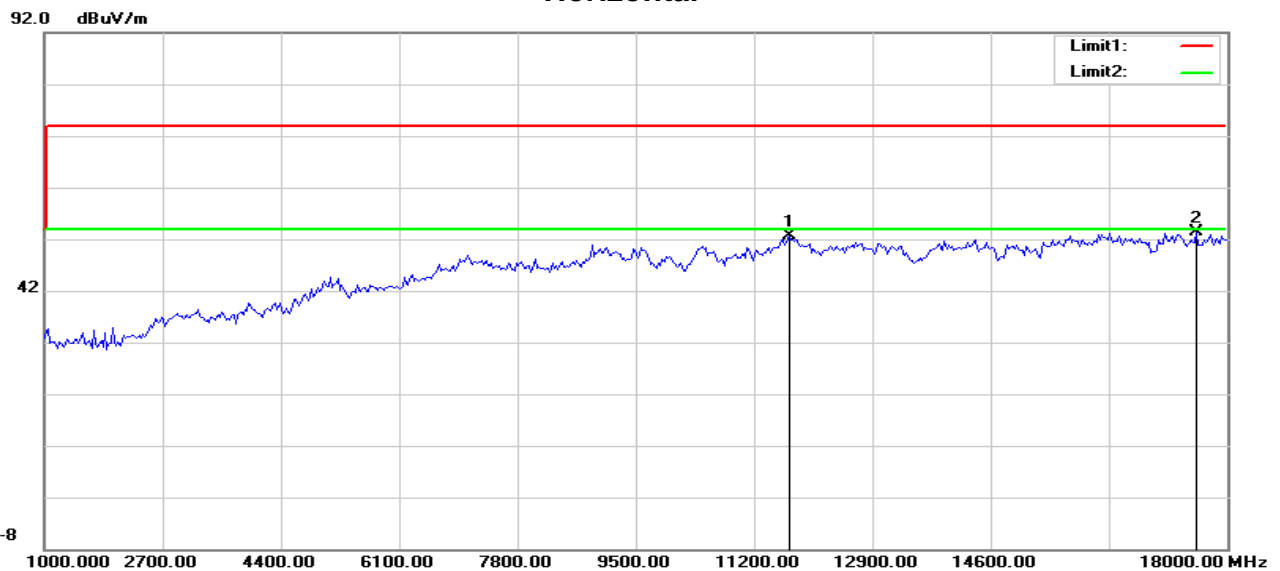

No.	Frequency (MHz)	Reading (dBuV)	Correct Factor(dB/m)	Result (dBuV/m)	Limit (dBuV/m)	Margin (dB)	Height (cm)	Degree (deg.)	Remark
1	11706.731	41.02	11.64	52.66	74.00	-21.34	100	30	peak
2	17564.103	35.58	17.68	53.26	74.00	-20.74	100	283	peak

Vertical

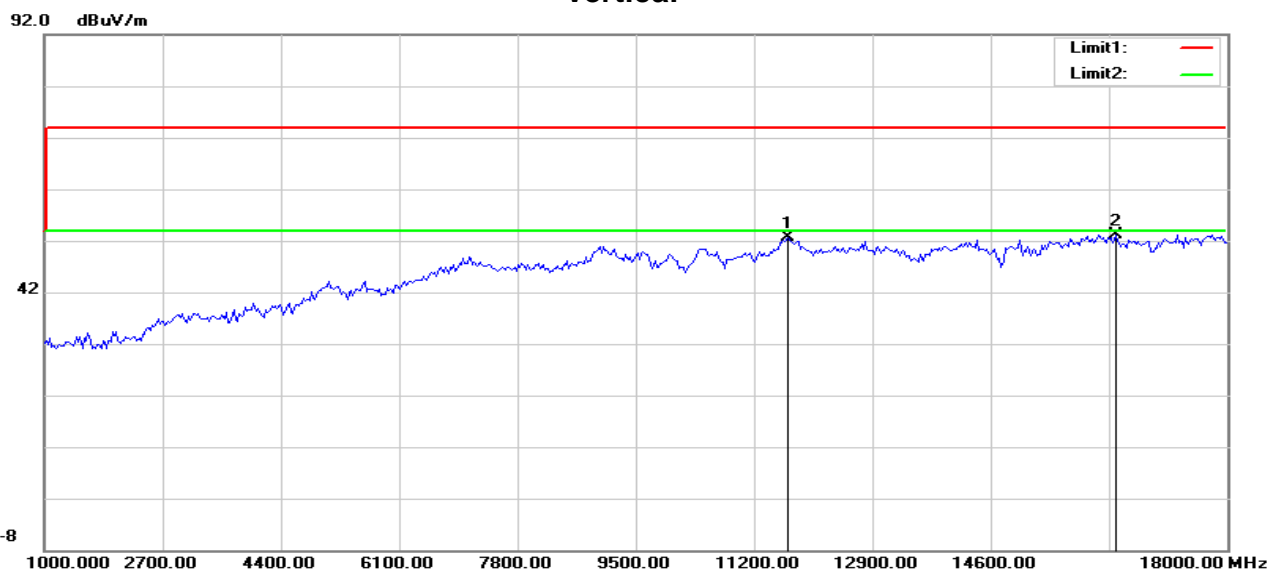

No.	Frequency (MHz)	Reading (dBuV)	Correct Factor(dB/m)	Result (dBuV/m)	Limit (dBuV/m)	Margin (dB)	Height (cm)	Degree (deg.)	Remark
1	11679.487	41.01	11.60	52.61	74.00	-21.39	100	103	peak
2	16392.628	38.79	14.43	53.22	74.00	-20.78	100	12	peak

Operation Mode: TX / IEEE 802.11g / CH Low

Test Date: 2018-10-16

Temperature: 25°C

Tested by: Tim.cao

Humidity: 51% RH

Polarity: Ver. / Hor.

Horizontal

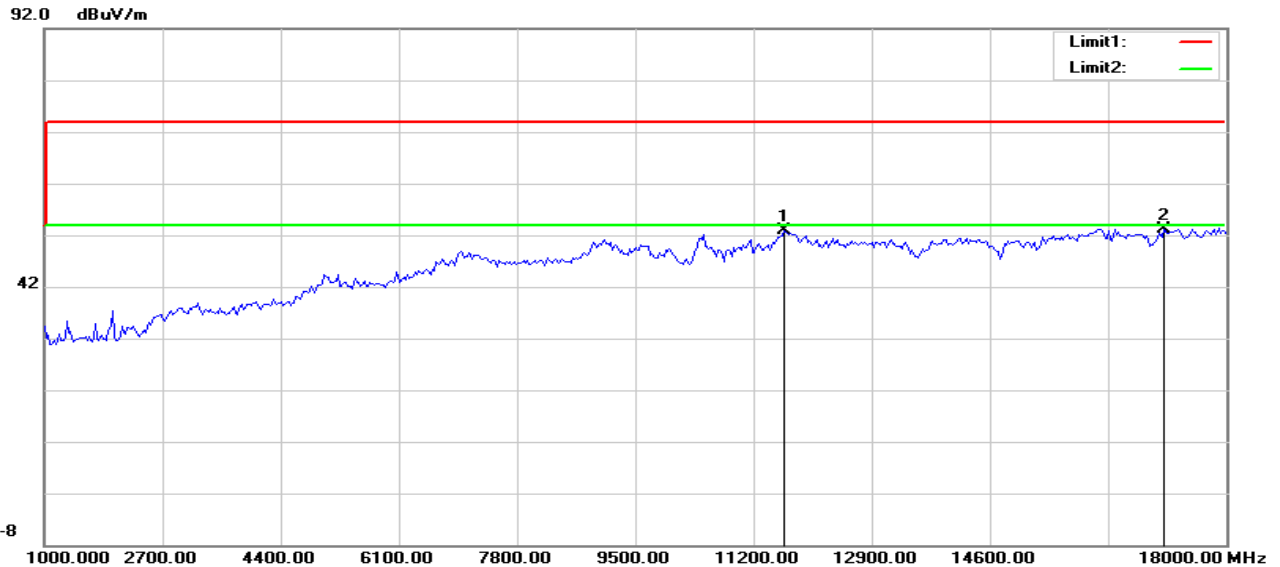

No.	Frequency (MHz)	Reading (dBuV)	Correct Factor(dB/m)	Result (dBuV/m)	Limit (dBuV/m)	Margin (dB)	Height (cm)	Degree (deg.)	Remark
1	11652.244	41.34	11.55	52.89	74.00	-21.11	200	75	peak
2	17100.962	37.22	16.02	53.24	74.00	-20.76	200	124	peak

Vertical

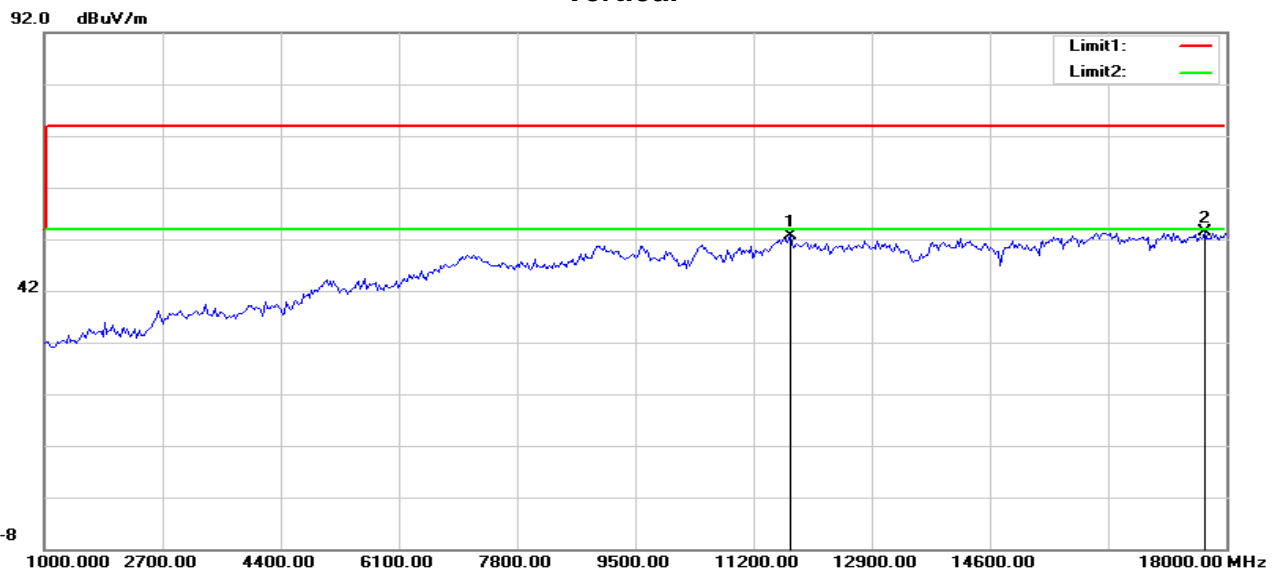

No.	Frequency (MHz)	Reading (dBuV)	Correct Factor(dB/m)	Result (dBuV/m)	Limit (dBuV/m)	Margin (dB)	Height (cm)	Degree (deg.)	Remark
1	11733.974	41.02	11.69	52.71	74.00	-21.29	100	182	peak
2	17700.321	35.68	17.82	53.50	74.00	-20.50	200	36	peak

Operation Mode: TX / IEEE 802.11g / CH Mid
Temperature: 25°C
Humidity: 51% RH

Test Date: 2018-10-16
Tested by: Tim.cao
Polarity: Ver. / Hor.

Horizontal

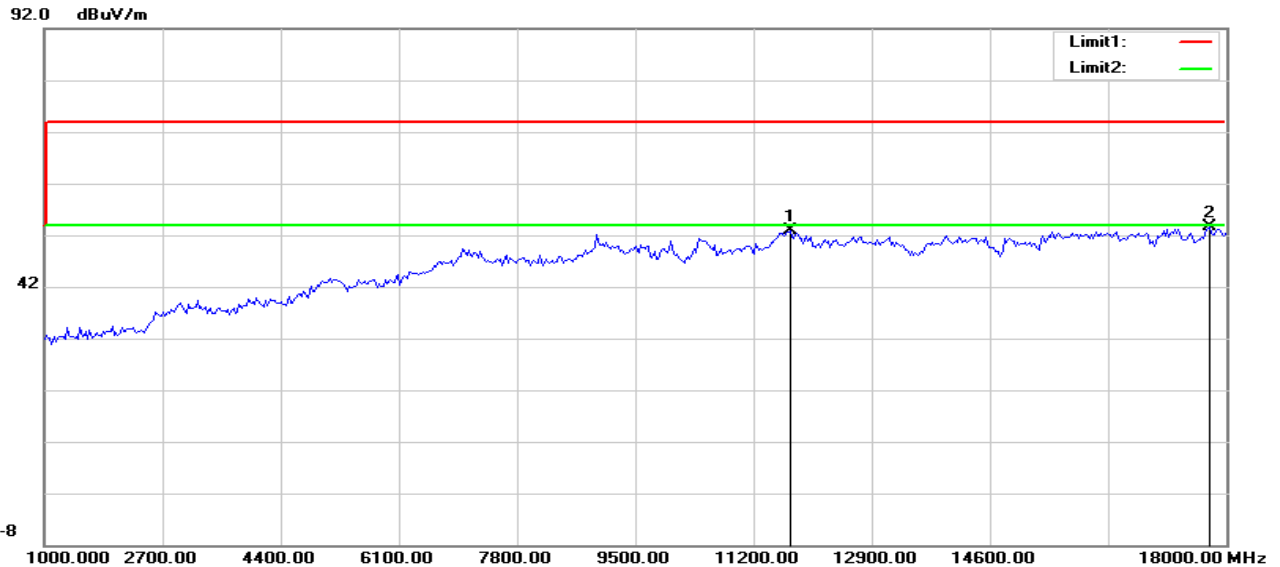

No.	Frequency (MHz)	Reading (dBuV)	Correct Factor(dB/m)	Result (dBuV/m)	Limit (dBuV/m)	Margin (dB)	Height (cm)	Degree (deg.)	Remark
1	11733.974	41.13	11.69	52.82	74.00	-21.18	100	24	peak
2	17754.808	35.77	17.88	53.65	74.00	-20.35	200	84	peak

Vertical

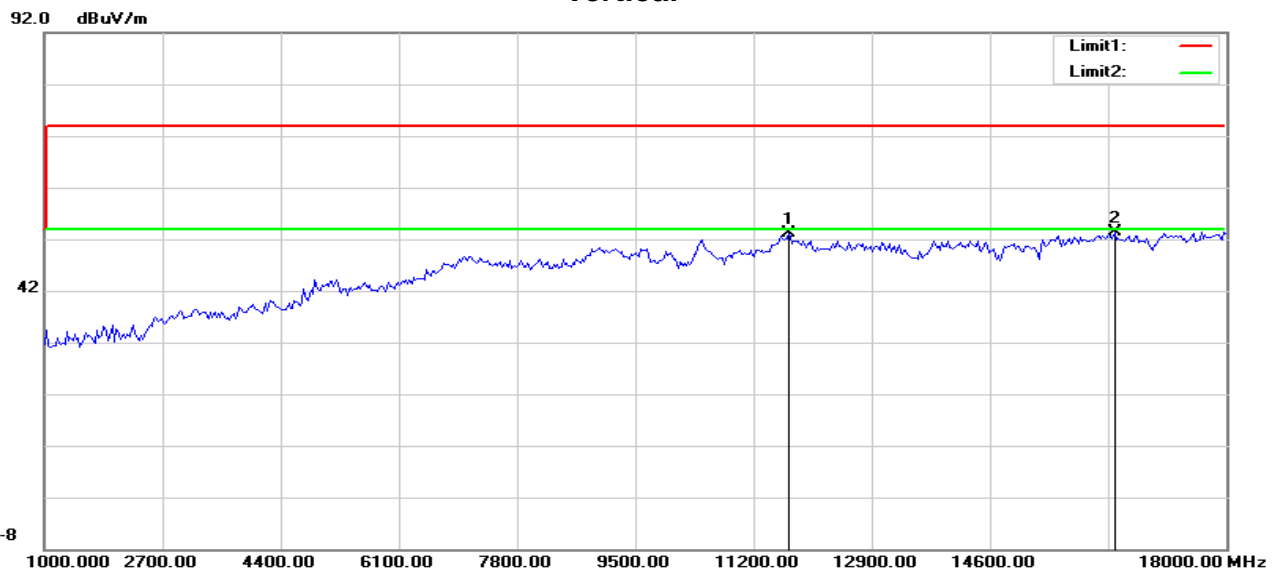

No.	Frequency (MHz)	Reading (dBuV)	Correct Factor(dB/m)	Result (dBuV/m)	Limit (dBuV/m)	Margin (dB)	Height (cm)	Degree (deg.)	Remark
1	11706.731	41.38	11.64	53.02	74.00	-20.98	100	172	peak
2	16392.628	38.97	14.43	53.40	74.00	-20.60	153	360	peak

Operation Mode: TX / IEEE 802.11g / CH High

Test Date: 2018-10-16

Temperature: 25°C

Tested by: Tim.cao

Humidity: 51% RH

Polarity: Ver. / Hor.

Horizontal

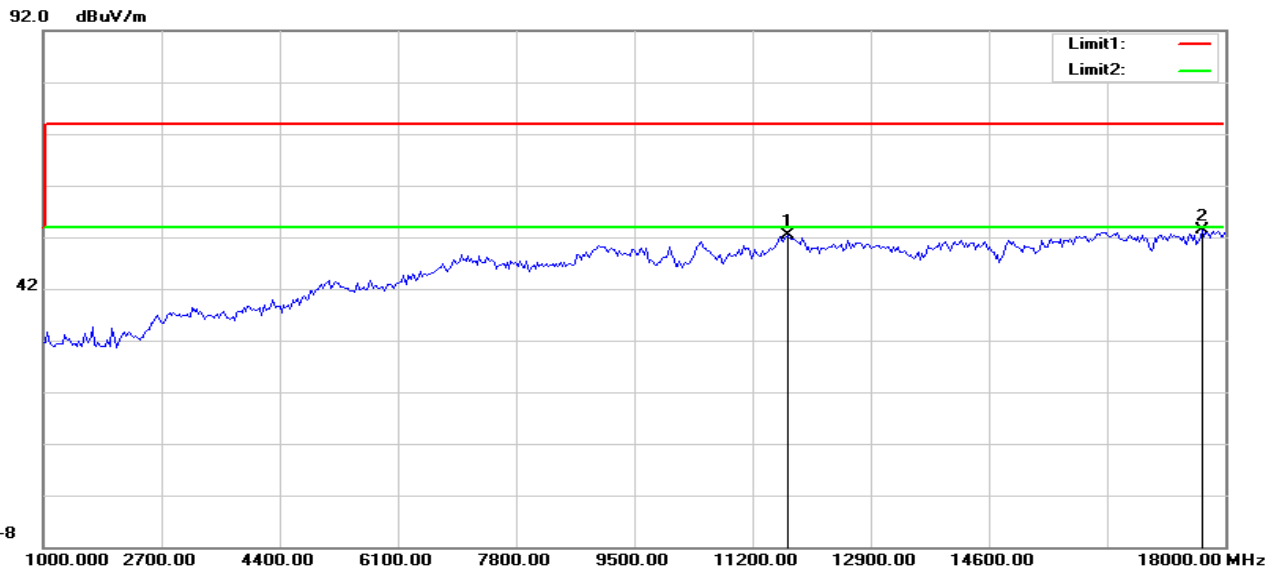

No.	Frequency (MHz)	Reading (dBuV)	Correct Factor(dB/m)	Result (dBuV/m)	Limit (dBuV/m)	Margin (dB)	Height (cm)	Degree (deg.)	Remark
1	11706.731	40.76	11.64	52.40	74.00	-21.60	100	141	peak
2	17673.077	35.62	17.79	53.41	74.00	-20.59	100	280	peak

Vertical

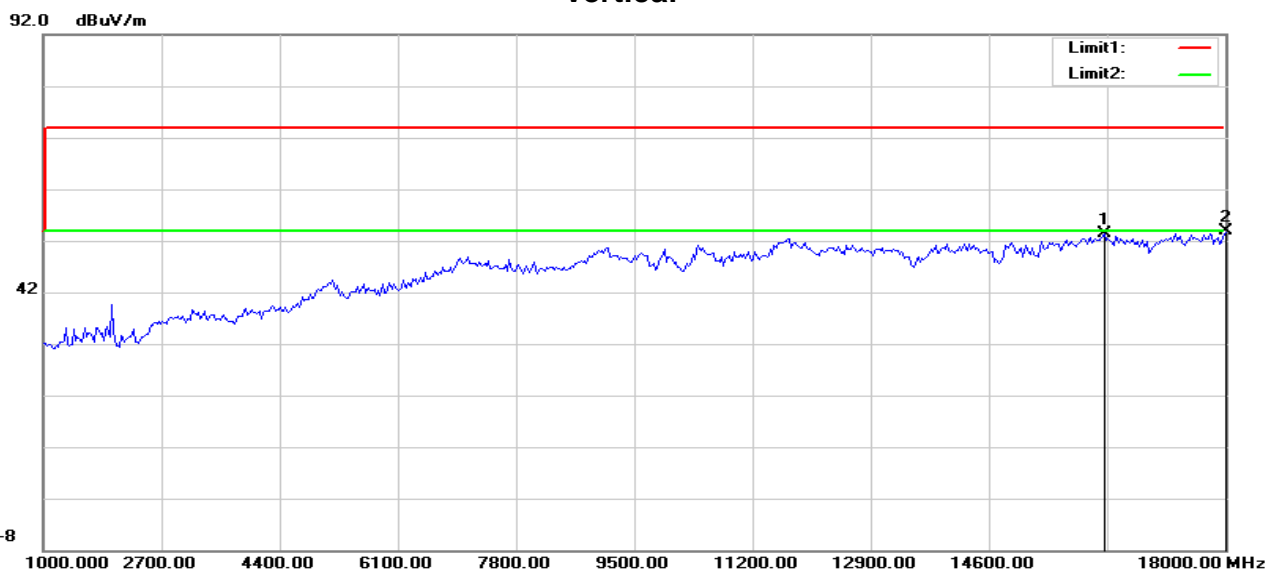

No.	Frequency (MHz)	Reading (dBuV)	Correct Factor(dB/m)	Result (dBuV/m)	Limit (dBuV/m)	Margin (dB)	Height (cm)	Degree (deg.)	Remark
1	16256.410	39.03	14.39	53.42	74.00	-20.58	100	61	peak
2	18000.000	35.84	18.13	53.97	74.00	-20.03	100	360	peak

Operation Mode: TX / IEEE 802.11n HT20 mode / CH Low
 Temperature: 25°C
 Humidity: 51% RH

Test Date: 2018-10-16
 Tested by: Tim.cao
 Polarity: Ver. / Hor.

Horizontal

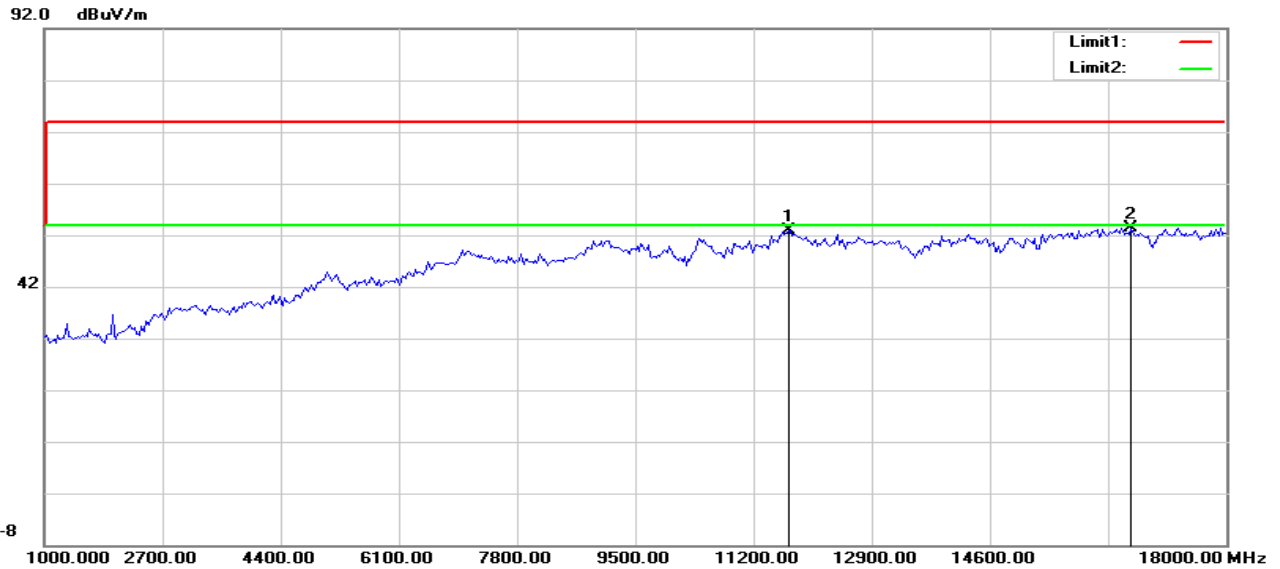

No.	Frequency (MHz)	Reading (dBuV)	Correct Factor(dB/m)	Result (dBuV/m)	Limit (dBuV/m)	Margin (dB)	Height (cm)	Degree (deg.)	Remark
1	11706.731	41.16	11.64	52.80	74.00	-21.20	200	360	peak
2	16637.821	38.53	14.79	53.32	74.00	-20.68	200	360	peak

Vertical

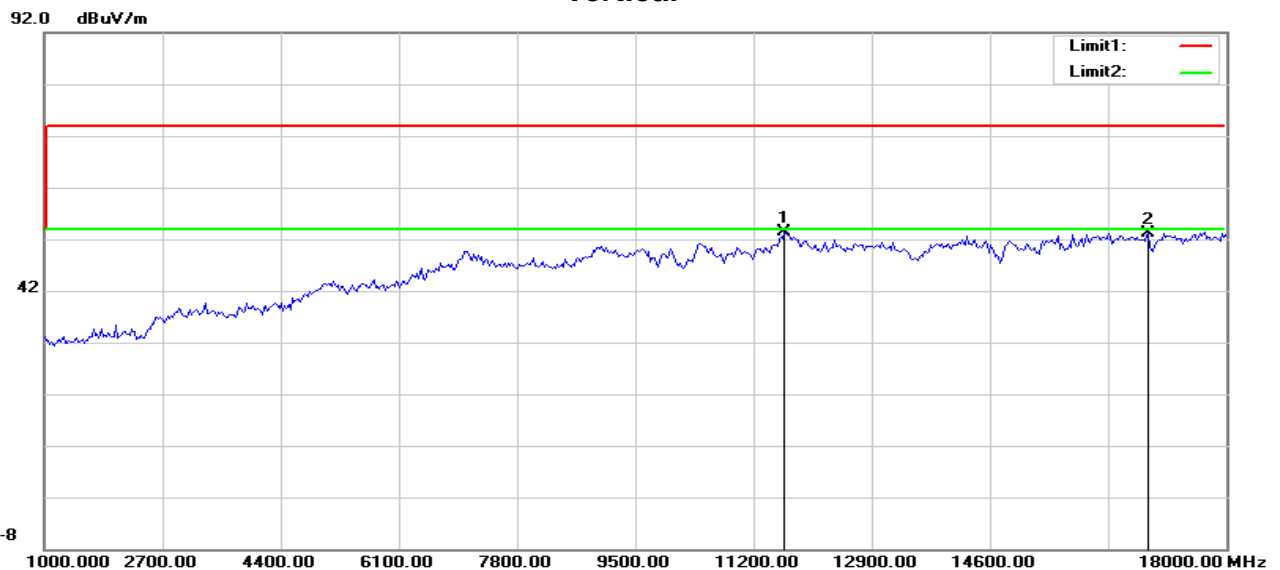

No.	Frequency (MHz)	Reading (dBuV)	Correct Factor(dB/m)	Result (dBuV/m)	Limit (dBuV/m)	Margin (dB)	Height (cm)	Degree (deg.)	Remark
1	11652.244	41.95	11.55	53.50	74.00	-20.50	100	360	peak
2	16883.013	37.89	15.35	53.24	74.00	-20.76	100	360	peak

Operation Mode: TX / IEEE 802.11n HT20 mode / CH Mid

Test Date: 2018-10-16

Temperature: 25°C

Tested by: Tim.cao

Humidity: 51% RH

Polarity: Ver. / Hor.

Horizontal

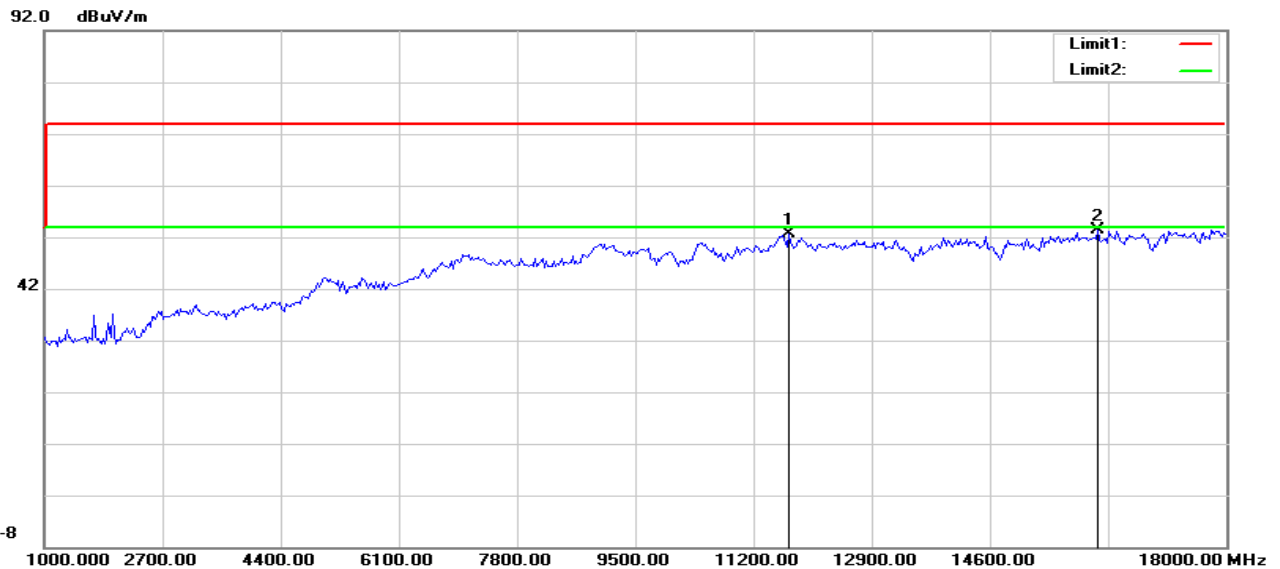

No.	Frequency (MHz)	Reading (dBuV)	Correct Factor(dB/m)	Result (dBuV/m)	Limit (dBuV/m)	Margin (dB)	Height (cm)	Degree (deg.)	Remark
1	11706.731	40.88	11.64	52.52	74.00	-21.48	100	320	peak
2	16147.436	39.13	14.35	53.48	74.00	-20.52	200	259	peak

Vertical

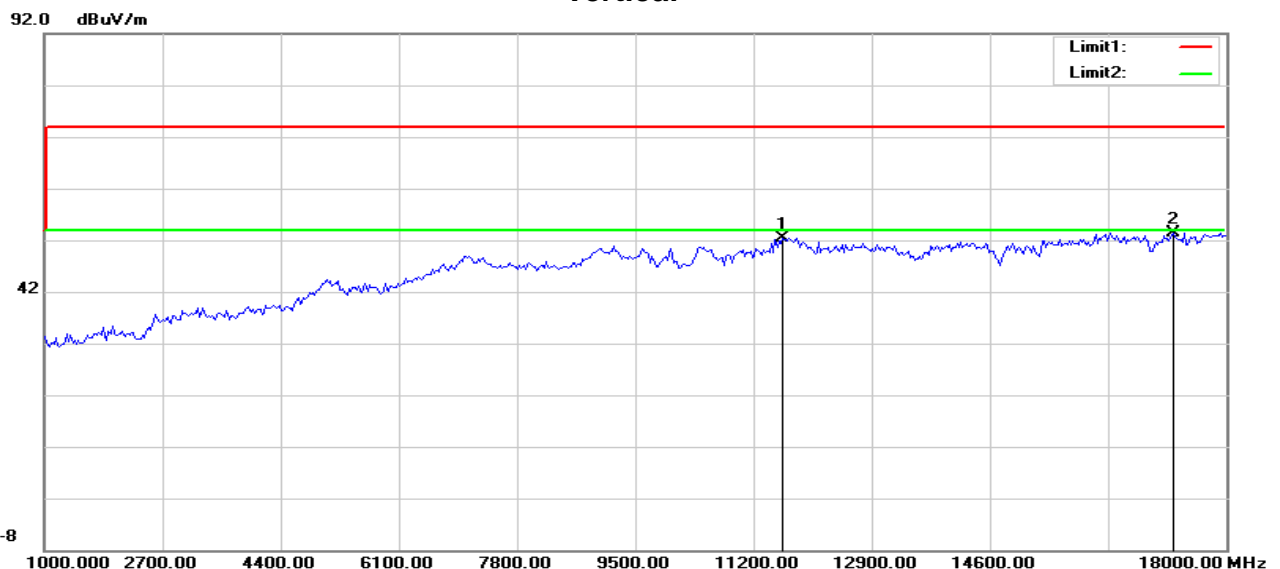

No.	Frequency (MHz)	Reading (dBuV)	Correct Factor(dB/m)	Result (dBuV/m)	Limit (dBuV/m)	Margin (dB)	Height (cm)	Degree (deg.)	Remark
1	11625.000	40.99	11.50	52.49	74.00	-21.51	100	360	peak
2	17237.179	36.91	16.56	53.47	74.00	-20.53	200	145	peak

Operation Mode: TX / IEEE 802.11n HT20 mode / CH High **Test Date:** 2018-10-16

Temperature: 25°C

Tested by: Tim.cao

Humidity: 51% RH

Polarity: Ver. / Hor.

Horizontal

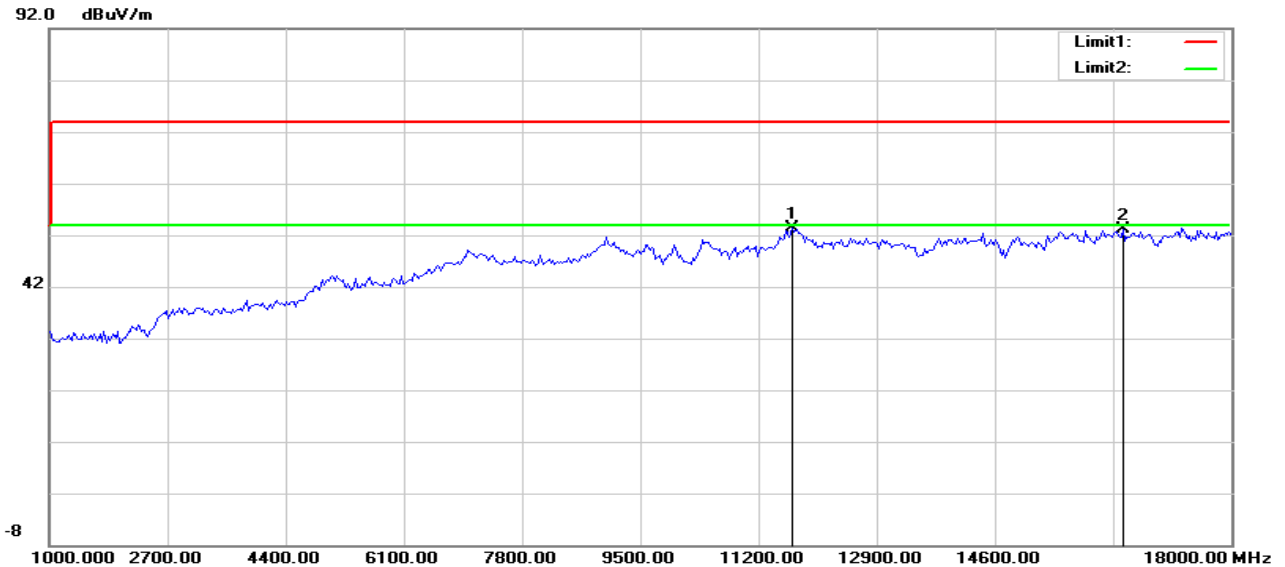

No.	Frequency (MHz)	Reading (dBuV)	Correct Factor(dB/m)	Result (dBuV/m)	Limit (dBuV/m)	Margin (dB)	Height (cm)	Degree (deg.)	Remark
1	11679.487	41.68	11.60	53.28	74.00	-20.72	106	0	peak
2	16447.115	38.71	14.45	53.16	74.00	-20.84	200	348	peak

Vertical

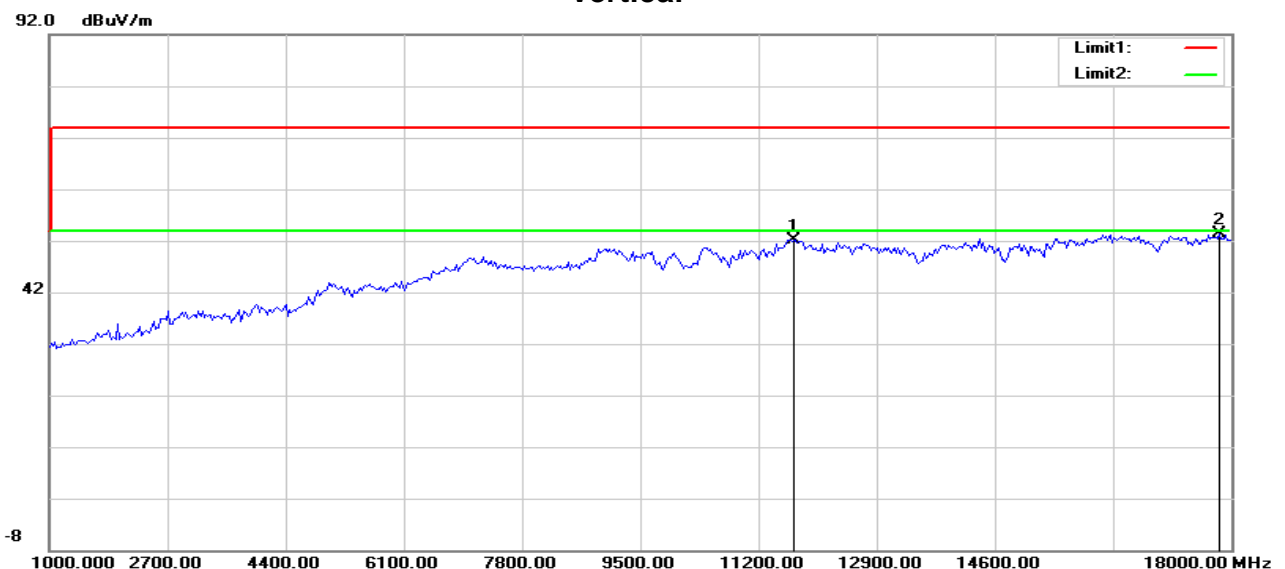

No.	Frequency (MHz)	Reading (dBuV)	Correct Factor(dB/m)	Result (dBuV/m)	Limit (dBuV/m)	Margin (dB)	Height (cm)	Degree (deg.)	Remark
1	11706.731	40.59	11.64	52.23	74.00	-21.77	200	4	peak
2	17836.538	35.46	17.96	53.42	74.00	-20.58	200	156	peak

7.6.POWERLINE CONDUCTED EMISSIONS

LIMIT

According to §15.207(a), except as shown in paragraphs (b) and (c) of this section, for an intentional radiator that is designed to be connected to the public utility (AC) power line, the radio frequency voltage that is conducted back onto the AC power line on any frequency or frequencies within the band 150 kHz to 30 MHz shall not exceed the limits in the following table, as measured using a 50 μ H/50 ohms line impedance stabilization network (LISN). Compliance with the provisions of this paragraph shall be based on the measurement of the radio frequency voltage between each power line and ground at the power terminal. The lower limit applies at the boundary between the frequency ranges.

Frequency Range (MHz)	Limits (dB μ V)	
	Quasi-peak	Average
0.15 to 0.50	66 to 56*	56 to 46*
0.50 to 5	56	46
5 to 30	60	50

* Decreases with the logarithm of the frequency.

Test Configuration

See test photographs attached in Setup photo for the actual connections between EUT and support equipment.

TEST PROCEDURE

- 1.The EUT was placed on a turntable, which is 0.8m above ground plane.
- 2.Maximum procedure was performed on the six highest emissions to ensure EUT compliance.
- 3.Repeat above procedures until all frequency measured were complete.

TEST RESULTS

The initial step in collecting conducted data is a spectrum analyzer peak scan of the measurement range. Significant peaks are then marked as shown on the following data page, and these signals are then quasi-peaked.

TEST DATA

Job No.:	C180918R02	Date:	2018/11/19
Model No.:	SPB308	Time:	9:30:17
Standard:	FCC Class B	Temp.(C)/Hum.(%):	22(C)/41%
Test item:	Conduction test	Test By:	Tao.Jiang
Line:	L1	Test Voltage:	AC 120V/60Hz
Model:		Description:	

L1

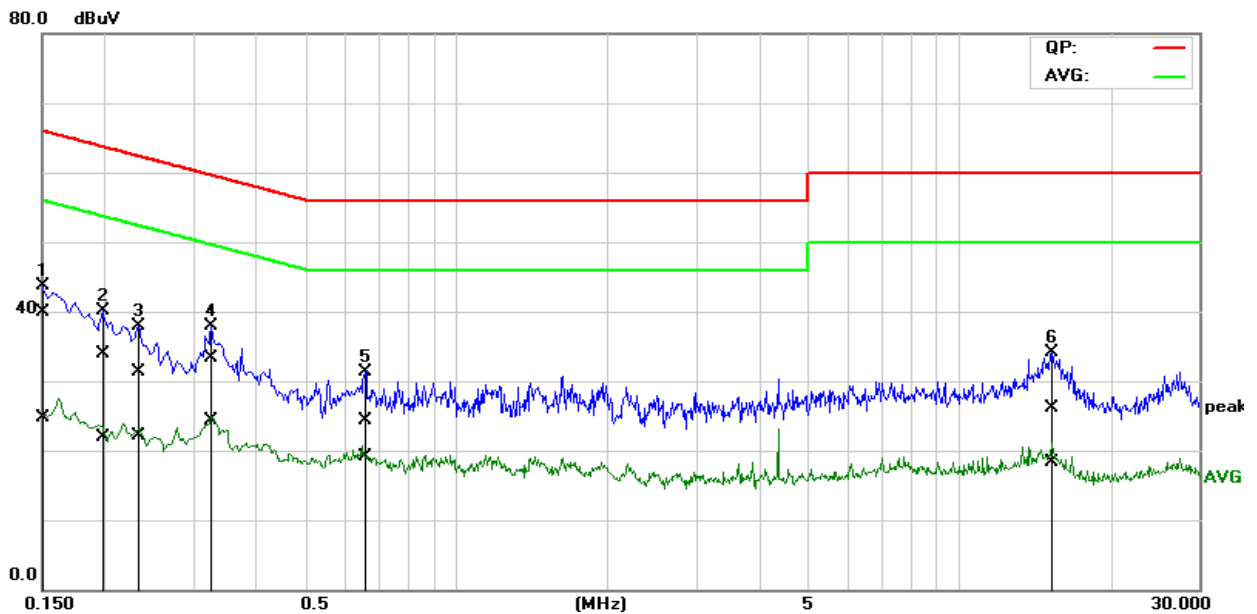

No.	Frequency (MHz)	QuasiPeak reading (dBuV)	Average reading (dBuV)	Correction factor (dB)	QuasiPeak result (dBuV)	Average result (dBuV)	QuasiPeak limit (dBuV)	Average limit (dBuV)	QuasiPeak margin (dB)	Average margin (dB)	Remark
1	0.1500	20.41	5.26	19.42	39.83	24.68	66.00	56.00	-26.17	-31.32	Pass
2	0.1960	14.48	2.50	19.45	33.93	21.95	63.78	53.78	-29.85	-31.83	Pass
3	0.2313	11.86	2.58	19.46	31.32	22.04	62.40	52.40	-31.08	-30.36	Pass
4*	0.3258	13.89	4.92	19.48	33.37	24.40	59.56	49.56	-26.19	-25.16	Pass
5	0.6525	4.79	-0.45	19.52	24.31	19.07	56.00	46.00	-31.69	-26.93	Pass
6	15.2879	6.13	-1.80	20.06	26.19	18.26	60.00	50.00	-33.81	-31.74	Pass

Note: 1. L1 = Line One (Live Line) / L2 = Line Two (Neutral Line).

Job No.:	C180918R02	Date:	2018/11/19
Model No.:	SPB308	Time:	9:34:54
Standard:	FCC Class B	Temp.(C)/Hum.(%):	22(C)/41%
Test item:	Conduction test	Test By:	Tao.Jiang
Line:	L2	Test Voltage:	AC 120V/60Hz
Model:		Description:	

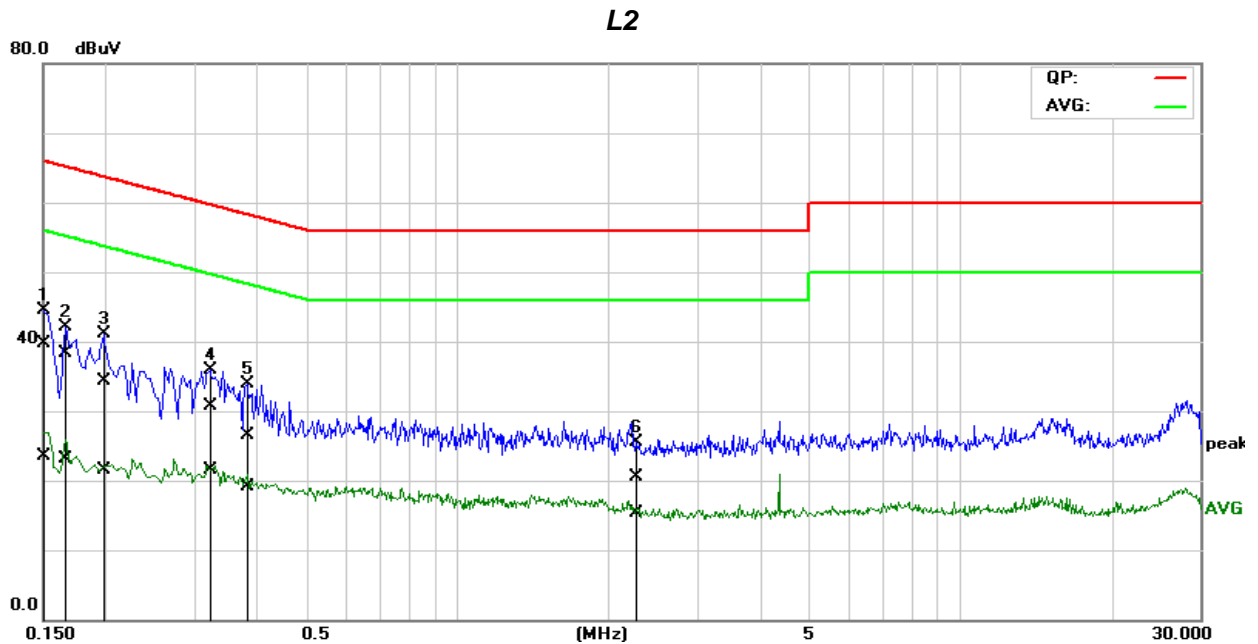

No.	Frequency (MHz)	QuasiPeak reading (dBuV)	Average reading (dBuV)	Correction factor (dB)	QuasiPeak result (dBuV)	Average result (dBuV)	QuasiPeak limit (dBuV)	Average limit (dBuV)	QuasiPeak margin (dB)	Average margin (dB)	Remark
1*	0.1500	20.33	4.09	19.41	39.74	23.50	66.00	56.00	-26.26	-32.50	Pass
2	0.1663	18.95	3.66	19.42	38.37	23.08	65.14	55.14	-26.77	-32.06	Pass
3	0.1968	14.93	2.07	19.44	34.37	21.51	63.74	53.74	-29.37	-32.23	Pass
4	0.3221	11.15	2.00	19.47	30.62	21.47	59.65	49.65	-29.03	-28.18	Pass
5	0.3796	7.12	-0.39	19.47	26.59	19.08	58.29	48.29	-31.70	-29.21	Pass
6	2.2493	0.86	-4.25	19.58	20.44	15.33	56.00	46.00	-35.56	-30.67	Pass

Note: 1. L1 = Line One (Live Line) / L2 = Line Two (Neutral Line).

Job No.:	C180918R02	Date:	2018/11/19
Model No.:	SPB308	Time:	9:14:04
Standard:	FCC Class B	Temp.(C)/Hum.(%):	22(C)/41%
Test item:	Conduction test	Test By:	Tao.Jiang
Line:	L1	Test Voltage:	AC 240V/60Hz
Model:		Description:	

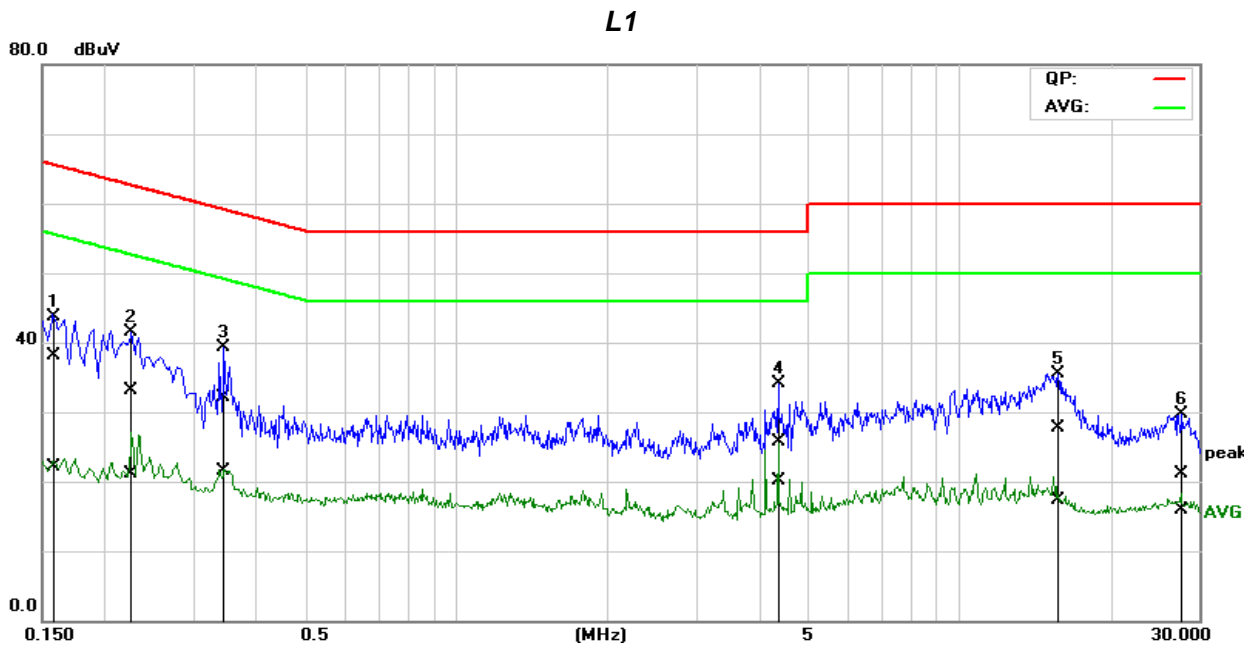

No.	Frequency (MHz)	QuasiPeak reading (dBuV)	Average reading (dBuV)	Correction factor (dB)	QuasiPeak result (dBuV)	Average result (dBuV)	QuasiPeak limit (dBuV)	Average limit (dBuV)	QuasiPeak margin (dB)	Average margin (dB)	Remark
1	0.1594	18.76	2.62	19.43	38.19	22.05	65.50	55.50	-27.31	-33.45	Pass
2	0.2266	13.62	1.71	19.46	33.08	21.17	62.57	52.57	-29.49	-31.40	Pass
3	0.3438	12.53	2.06	19.48	32.01	21.54	59.11	49.11	-27.10	-27.57	Pass
4*	4.3744	6.08	0.44	19.67	25.75	20.11	56.00	46.00	-30.25	-25.89	Pass
5	15.7583	7.73	-2.85	20.06	27.79	17.21	60.00	50.00	-32.21	-32.79	Pass
6	27.8544	1.13	-4.08	20.07	21.20	15.99	60.00	50.00	-38.80	-34.01	Pass

Note: 1. L1 = Line One (Live Line) / L2 = Line Two (Neutral Line).

Job No.:	C180918R02	Date:	2018/11/19
Model No.:	SPB308	Time:	9:19:18
Standard:	FCC Class B	Temp.(C)/Hum.(%):	22(C)/41%
Test item:	Conduction test	Test By:	Tao.Jiang
Line:	L2	Test Voltage:	AC 240V/60Hz
Model:		Description:	

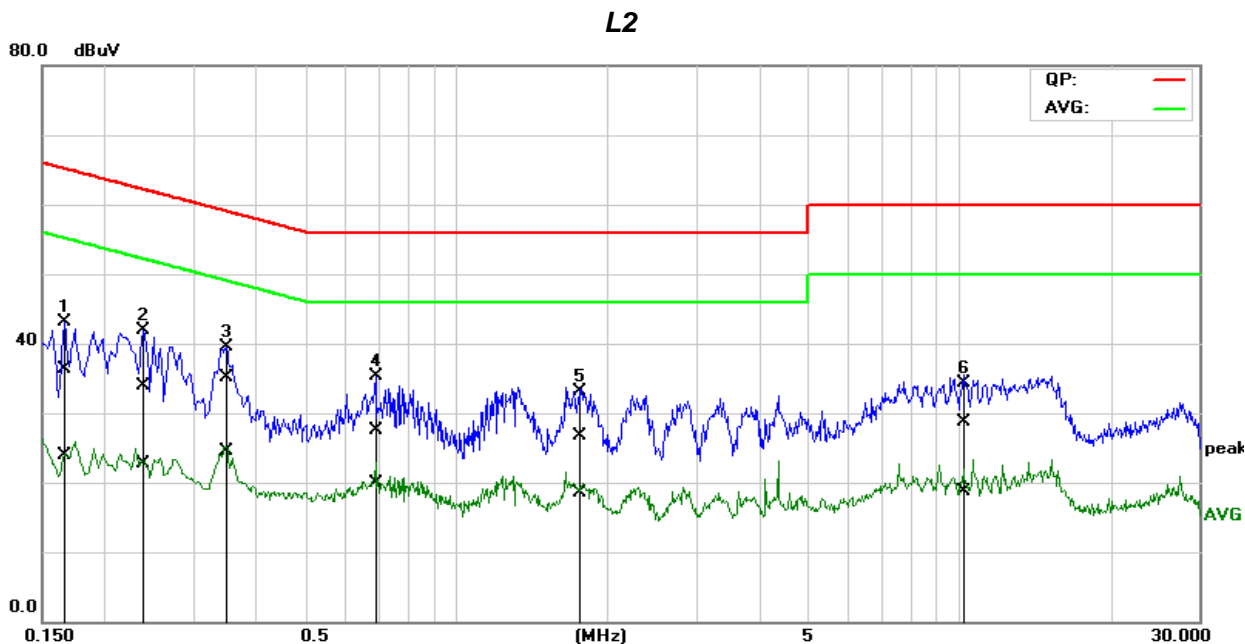

No.	Frequency (MHz)	QuasiPeak reading (dBuV)	Average reading (dBuV)	Correction factor (dB)	QuasiPeak result (dBuV)	Average result (dBuV)	QuasiPeak limit (dBuV)	Average limit (dBuV)	QuasiPeak margin (dB)	Average margin (dB)	Remark
1	0.1633	16.89	4.47	19.42	36.31	23.89	65.29	55.29	-28.98	-31.40	Pass
2	0.2382	14.36	3.28	19.45	33.81	22.73	62.16	52.16	-28.35	-29.43	Pass
3*	0.3465	15.58	5.03	19.47	35.05	24.50	59.05	49.05	-24.00	-24.55	Pass
4	0.6945	7.90	0.34	19.52	27.42	19.86	56.00	46.00	-28.58	-26.14	Pass
5	1.7386	7.22	-1.10	19.56	26.78	18.46	56.00	46.00	-29.22	-27.54	Pass
6	10.2990	8.92	-1.11	19.86	28.78	18.75	60.00	50.00	-31.22	-31.25	Pass

Note: 1. L1 = Line One (Live Line) / L2 = Line Two (Neutral Line).

Remark:

1. The measuring frequencies range between 0.15 MHz and 30 MHz.
2. The emissions measured in the frequency range between 0.15 MHz and 30MHz were made with an instrument using Quasi-peak detector and Average detector.
3. “---” denotes the emission level was or more than 2dB below the Average limit, and no re-check was made.
4. The IF bandwidth of SPA between 0.15MHz and 30MHz was 10KHz. The IF bandwidth of Test Receiver between 0.15MHz and 30MHz was 9kHz.

END OF REPORT