

## 2.4GHz Chip Antenna: AAN3216H4R2G45

### Application:

WLAN, 802.11b/g, Bluetooth, etc...

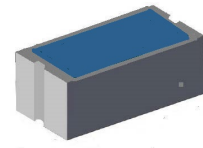

### Features

SMD, high reliability, ultra Impact, Omni-directional...

### Part number

AAN 3216 H4 R 2G45  
 (1) (2) (3) (4) (5)

(1) Product Type	Chip Antenna
(2) Size Code	3.2x1.6mm
(3) Type Code	H4
(4) Packing	Tape and reel
(5) Frequency	2.45GHz

### Electrical Specification

Working Frequency Range	2400 ~2484 MHz
Peak Gain	3.0dBi (Typ.)
Impedance	50 Ohm
Return loss	10 dB ( Min)
Polarization	Linear
Azimuth Beamwidth	Omni-directional
Operation Temperature(°C)	-40 ~85°C

The specification is defined on EVB.

### Dimension and Terminal Configuration

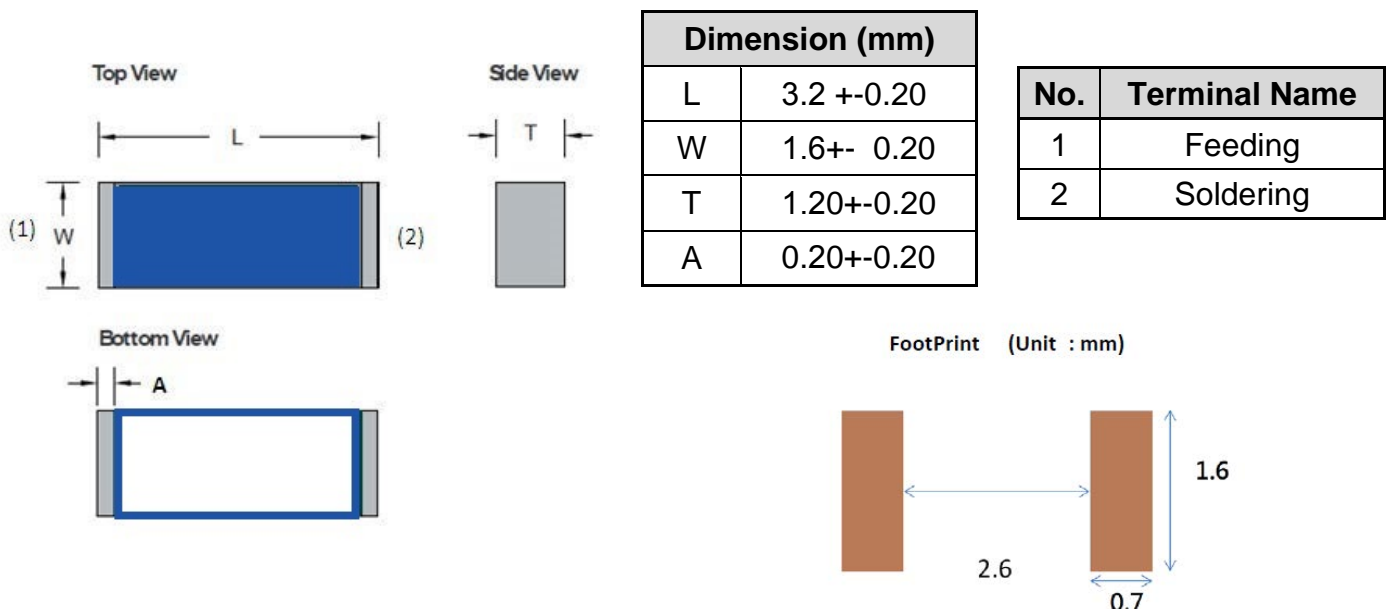

# 2.4GHz 2.45GHz Chip Antenna: AAN3216H4R2G45

## Evaluation Board Reference

### PCB Dimension & Antenna Layout Reference

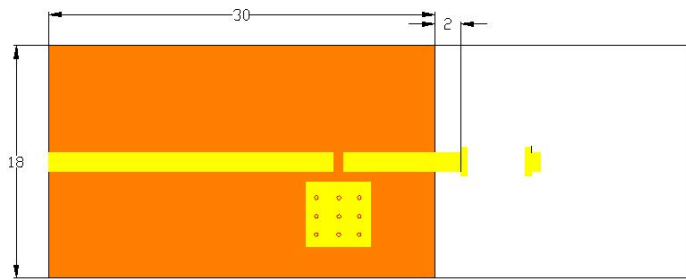

unit :mm

## Electrical Characteristics

### Return Loss & Radiation

#### Return Loss

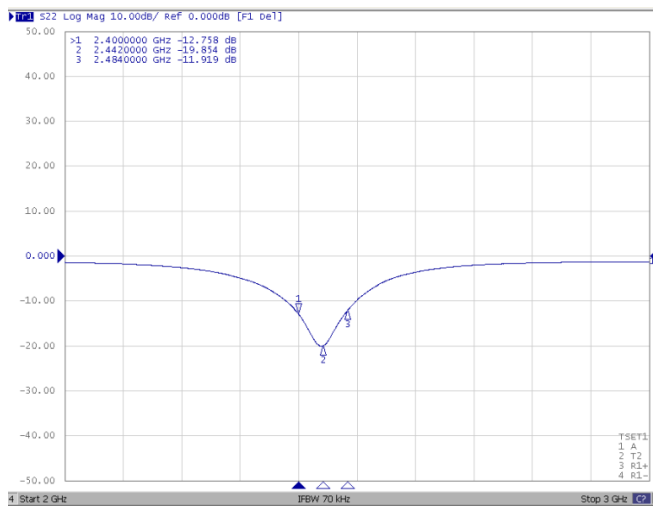

Frequency (MHz)	S11 (dB)
2400	-12.8
2442	-19.8
2484	-11.9

#### Radiation

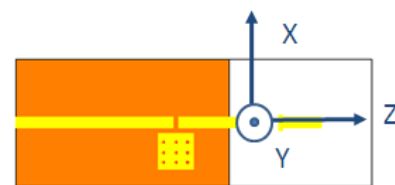
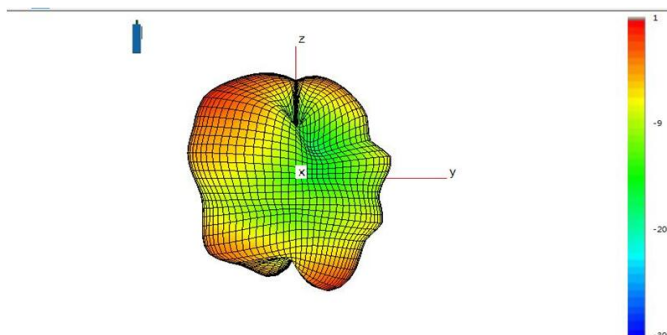

#### 2.45GHz

Frequency	2445MHz
Peak gain	3.0dBi
Efficiency	79.2%

## 2.4GHz 2.45GHz Chip Antenna: AAN3216H4R2G45

### Taping Specifications

Reel	Taping Blister Tape																																															
<table border="1"> <thead> <tr> <th>Checking note</th> <th>Index</th> <th>Spec (mm)</th> </tr> </thead> <tbody> <tr> <td>Internal diameter of reel</td> <td>A</td> <td><math>60.20 \pm 0.50</math></td> </tr> <tr> <td>External diameter of reel</td> <td>B</td> <td><math>178 \pm 1.00</math></td> </tr> </tbody> </table>	Checking note	Index	Spec (mm)	Internal diameter of reel	A	$60.20 \pm 0.50$	External diameter of reel	B	$178 \pm 1.00$	<table border="1"> <thead> <tr> <th>Checking note</th> <th>Index</th> <th>Spec (mm)</th> </tr> </thead> <tbody> <tr> <td>Sprocket hole</td> <td>D0</td> <td><math>1.50 +0.10/-0.00</math></td> </tr> <tr> <td>Distance sprocket hole to outside</td> <td>E1</td> <td><math>1.75 \pm 0.10</math></td> </tr> <tr> <td>Distance sprocket hole to pocket</td> <td>F</td> <td><math>5.50 \pm 0.05</math></td> </tr> <tr> <td>Distance sprocket hole to sprocket hole</td> <td>P0</td> <td><math>4.00 \pm 0.10</math></td> </tr> <tr> <td>Distance pocket to pocket</td> <td>P1</td> <td><math>4.00 \pm 0.10</math></td> </tr> <tr> <td>Distance sprocket hole to pocket</td> <td>P2</td> <td><math>2.00 \pm 0.05</math></td> </tr> <tr> <td>Tape width</td> <td>W</td> <td><math>12.00 +0.30/-0.10</math></td> </tr> <tr> <td>Pocket width nominal clearance</td> <td>A0</td> <td><math>2.28 \pm 0.13</math></td> </tr> <tr> <td>Pocket length nominal clearance</td> <td>B0</td> <td><math>5.70 \pm 0.13</math></td> </tr> <tr> <td>Pocket depth minimum clearance</td> <td>K0</td> <td><math>1.58 \pm 0.10</math></td> </tr> <tr> <td>Thickness of tape</td> <td>T</td> <td><math>0.23 \pm 0.02</math></td> </tr> </tbody> </table>			Checking note	Index	Spec (mm)	Sprocket hole	D0	$1.50 +0.10/-0.00$	Distance sprocket hole to outside	E1	$1.75 \pm 0.10$	Distance sprocket hole to pocket	F	$5.50 \pm 0.05$	Distance sprocket hole to sprocket hole	P0	$4.00 \pm 0.10$	Distance pocket to pocket	P1	$4.00 \pm 0.10$	Distance sprocket hole to pocket	P2	$2.00 \pm 0.05$	Tape width	W	$12.00 +0.30/-0.10$	Pocket width nominal clearance	A0	$2.28 \pm 0.13$	Pocket length nominal clearance	B0	$5.70 \pm 0.13$	Pocket depth minimum clearance	K0	$1.58 \pm 0.10$	Thickness of tape	T	$0.23 \pm 0.02$
Checking note	Index	Spec (mm)																																														
Internal diameter of reel	A	$60.20 \pm 0.50$																																														
External diameter of reel	B	$178 \pm 1.00$																																														
Checking note	Index	Spec (mm)																																														
Sprocket hole	D0	$1.50 +0.10/-0.00$																																														
Distance sprocket hole to outside	E1	$1.75 \pm 0.10$																																														
Distance sprocket hole to pocket	F	$5.50 \pm 0.05$																																														
Distance sprocket hole to sprocket hole	P0	$4.00 \pm 0.10$																																														
Distance pocket to pocket	P1	$4.00 \pm 0.10$																																														
Distance sprocket hole to pocket	P2	$2.00 \pm 0.05$																																														
Tape width	W	$12.00 +0.30/-0.10$																																														
Pocket width nominal clearance	A0	$2.28 \pm 0.13$																																														
Pocket length nominal clearance	B0	$5.70 \pm 0.13$																																														
Pocket depth minimum clearance	K0	$1.58 \pm 0.10$																																														
Thickness of tape	T	$0.23 \pm 0.02$																																														
<table border="1"> <tbody> <tr> <td>Quantity/per reel</td> <td>2500 pcs</td> </tr> <tr> <td>Tape material</td> <td>Plastic (embossed)</td> </tr> </tbody> </table>	Quantity/per reel	2500 pcs	Tape material	Plastic (embossed)																																												
Quantity/per reel	2500 pcs																																															
Tape material	Plastic (embossed)																																															

## 2.4GHz 2.45GHz Chip Antenna: AAN3216H4R2G45

### Reliability Table

Test Item	Procedure	Requirements Ceramic Type	Remark (Reference)
<b>Electrical Characterization</b>		Fulfill the electrical specification	User Spec.
<b>Thermal Shock</b>	1. Preconditioning: $50 \pm 10^{\circ}\text{C}$ / 1 hr , then keep for $24 \pm 1$ hrs at room temp. 2. Initial measure: Spec: refer Initial spec. 3. Rapid change of temperature test: $-30^{\circ}\text{C}$ to $+85^{\circ}\text{C}$ ; 100 cycles; 15 minutes at Lower category temperature; 15 minutes at Upper category temperature.	No Visible Damage. Fulfill the electrical specification.	MIL-STD-202 107
<b>Temperature Cycling</b>	1. Initial measure: Spec: refer Initial spec. 2. 100 Cycles ( $-30^{\circ}\text{C}$ to $+85^{\circ}\text{C}$ ), Soak Mode=1 (2 Cycle/hours). 3. Measurement at $24 \pm 2$ Hours after test condition.	No Visible Damage. Fulfill the electrical specification.	JESD22 JA104
<b>High Temperature Exposure</b>	1. Initial measure: Spec: refer Initial spec. 2. Unpowered; 500hours @ $T=+85^{\circ}\text{C}$ . 3. Measurement at $24 \pm 2$ hours after test.	No Visible Damage. Fulfill the electrical specification.	MIL-STD-202 108
<b>Low Temperature Storage</b>	1. Initial measure: Spec: refer Initial spec. 2. Unpowered: 500hours @ $T= -30^{\circ}\text{C}$ . 3. Measurement at $24 \pm 2$ hours after test.	No Visible Damage. Fulfill the electrical specification.	MIL-STD-202 108
<b>Solderability (SMD Bottom Side)</b>	Dipping method: a. Temperature: $235 \pm 5^{\circ}\text{C}$ b. Dipping time: $3 \pm 0.5\text{s}$	The solder should cover over 95% of the critical area of bottom side.	IEC 60384-21/22 4.10
<b>Soldering Heat Resistance (RSH)</b>	Preheating temperature: $150 \pm 10^{\circ}\text{C}$ . Preheating time: 1~2 min. Solder temperature: $260 \pm 5^{\circ}\text{C}$ . Dipping time: $5 \pm 0.5\text{s}$	No Visible Damage.	IEC 60384-21/22 4.10
<b>Vibration</b>	5g's for 20 min., 12 cycles each of 3 orientations Note: Use 8"X5" PCB .031" thick 7 secure points on, one long side and 2 secure points at corners of opposite sides. Parts mounted within 2" from any secure point. Test from 10-2000 Hz.	No Visible Damage.	MIL-STD-202 Method 204
<b>Mechanical Shock</b>	Three shocks in each direction shall be applied along the three mutually perpendicular axes of the test specimen (18 shocks) Peak value: 1,500g's Duration: 0.5ms Velocity change: 15.4 ft/s Waveform: Half-sine	No Visible Damage.	MIL-STD-202 Method 213
<b>Humidity Bias</b>	1. Humidity: 85% R.H., Temperature: $85 \pm 2^{\circ}\text{C}$ . 2. Time: $500 \pm 24$ hours. 3. Measurement at $24 \pm 2$ hrs after test condition.	No Visible Damage. Fulfill the electrical specification.	MIL-STD-202 Method 106

## 2.4GHz 2.45GHz Chip Antenna: AAN3216H4R2G45

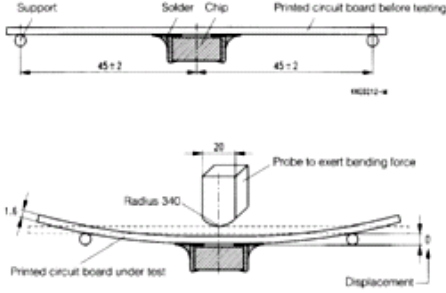
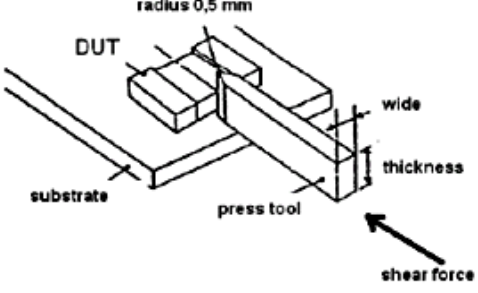
<b>Board Flex (SMD)</b>	<p>1. Mounting method: IR-Reflow. PCB Size (L:100 × W:40 × T:1.6mm)</p> <p>2. Apply the load in direction of the arrow until bending reaches 2 mm.</p> 	No Visible Damage.	AEC-Q200 005
<b>Adhesion</b>	<p>Force of 1.8Kg for 60 seconds.</p> 	No Visible Damage Magnification of 20X or greater may be employed for inspection of the mechanical integrity of the device body terminals and body/terminal junction.	AEC-Q200 006
<b>Physical Dimension</b>	<p>Any applicable method using x10 magnification, micrometers, calipers, gauges, contour projectors, or other measuring equipment, capable of determining the actual specimen dimensions.</p>	In accordance with specification.	JESD22 JB100

### Revision History

Revision	Date	Content
1	2019/7/26	New issue