



# Wireless Infrared Scouting Camera

## Enigma LTE AT&T

### Instruction Manual



## Content

1	Camera Overview .....	1
2	Quick start guide .....	2
2.1	Installing the batteries .....	2
2.2	Installing the SD card .....	2
2.3	Insert the SIM card.....	3
2.4	Downloading the Mobile App.....	3
2.5	Power switch and buttons .....	4
2.6	Setting map.....	5
2.7	Send a test photo .....	11
3	Connecting CAM to cloud server .....	12
3.1	Connecting CAM to cloud server.....	12
3.2	Send a photo to cloud server.....	14
3.3	Setting CAM with Web Portal or APP .....	15
4	Auxiliary power .....	17
5	Mount tips.....	17
	Appendix I : Technical Specifications .....	20
	Appendix II : Parts List.....	22

**What you will need to set this camera up:**

**-Internet Access to Cloud web portal**

**-12 AA Batteries**

**-SD Card**

**-SIM Card**

# 1 Camera Overview

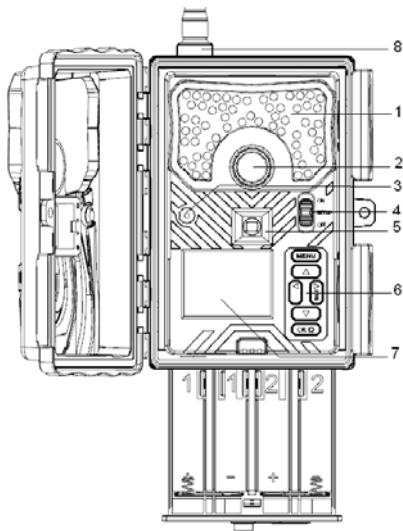

- |                          |                     |
|--------------------------|---------------------|
| 1: Black vision IR flash | 2: Lens             |
| 3: Light sensor          | 4: Power switch     |
| 5: PIR sensor            | 6: Key board        |
| 7: HD TFT screen         | 8: LTE main antenna |

(Fig 1 Operation Interface)

## **2 Quick start guide**

### **2.1 Installing the batteries**

This camera can function on 12AA batteries.

Pay attention to the (+) or (-) molded into each sleeve to determine if you insert the positive or negative end into the sleeve first. Negative battery terminal always contacts the spring.

Note:

- Do not mix different types of batteries
- Do not mix the old and new batteries
- Recommend high-density and high-performance batteries, such as Alkaline or Lithium batteries.
- Remove batteries when not in use to prevent leakage!

### **2.2 Installing the SD card**

To be able to power up the camera you will need to install a SD card in the slot in the bottom of the camera. You can use any SD card size up to 32GB. You must have the SD card in the camera to be able to turn the camera on and set it up.

## 2.3 Insert the SIM card

This product support B2/B4/B12 @ FDD LTE B2/B4/B5 @WCDMA.

**Be sure the PIN code of the SIM card is disabled, and there is enough money in the SIM card.**

## 2.4 Downloading the Mobile App

Search “firstcam” in your Google Play Store or Apple Store



Accessing the Web Portal:

Open your web browser to: [cloud.firstcampro.com](http://cloud.firstcampro.com).

You also can scan the QR code and install the APK file to your smart phone.



## 2.5 Power switch and buttons

Slide the power switch to SETUP position, then you can start setting the CAM as your favor.

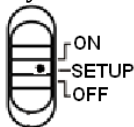

(Fig2 Power switch)

### **Power Switch:**

OFF: Power off (Please remove batteries when not in use);

SETUP: Setting the camera;

ON: Working mode (the screen will power off).

### **Buttons:**

MENU: Enter menu

▲ ▼ ◀ ▶ : Navigation button.

OK: Confirm operation /Playback photos or video clips.

▶ : To manually take photo or video. (Click again to stop the video.).

## 2.6 Setting map

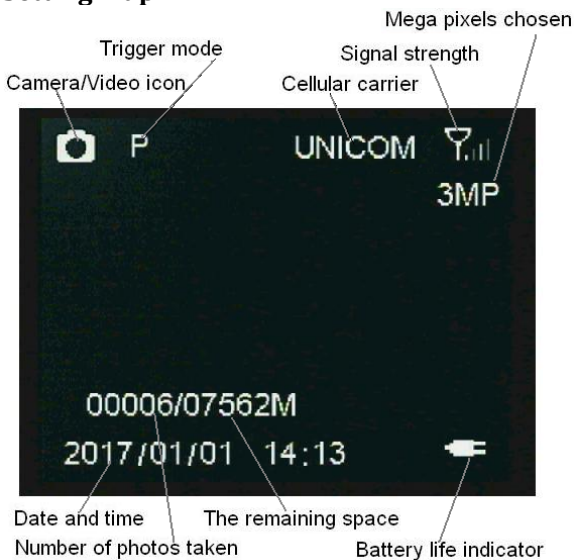

(Fig3 Main Screen)



## Settings:

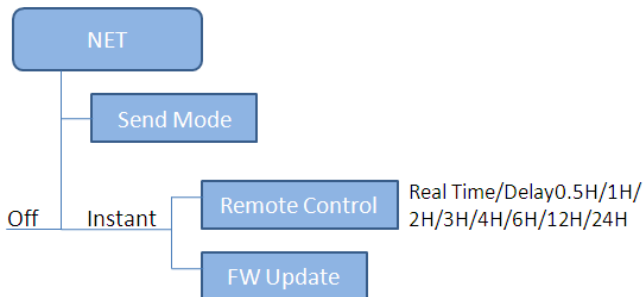

## Send Mode:

**Off:** Disable the transmission function.

**Instant:** Enable the instant transmission. **Max Number** of **Instant** means the number of photos that is allowed to send out per day. If you want to control your data flow, set the maximum number. The number **00** means infinity.

**Remote Control:** You can remote control your camera via mobile phone or web-portal. Choose Real Time, the

wireless module is keeping work so the power consumption is huge. Delay 24H means the wireless module will wake up at least one time in 24 hours.

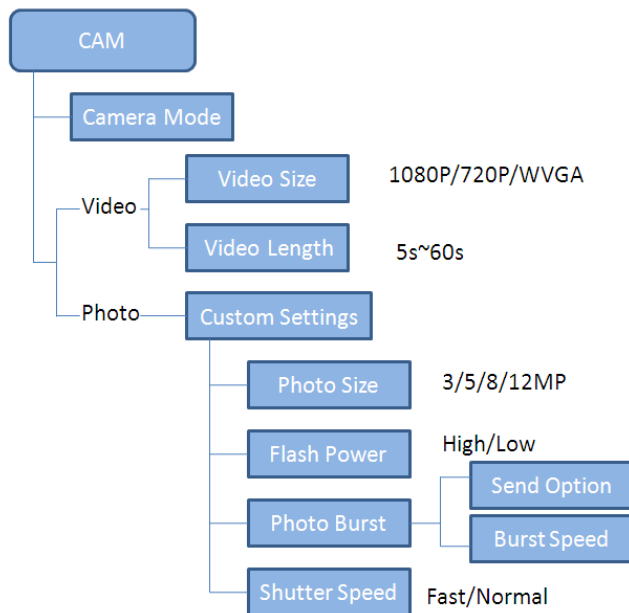

**Photo Burst:** It's the taken number of pictures when a triggering. If photo burst is 3, it means the camera will take 3 pictures after one triggering. You also can choose which one of the pictures will be sent via **Send Option**.

**Shutter Speed:** Normal is suitable for most application scenarios. Fast can be used to reduce motion blur.

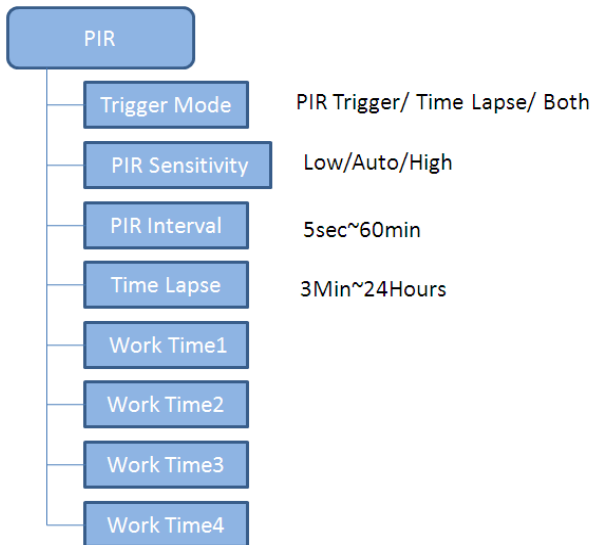

**PIR Interval:** It means how often the PIR sensor can be allowed to work. This prevents the card from filling up with too many redundant images.

**Time Lapse:** When choose time lapse, camera takes photos or videos even when it is not triggered by a nearby live animal. It's useful for constant monitoring of an area.

**Work Time:** The camera can work at a preset time and preset days. In the rest of the time the camera is not work. Work hour: 00:00-00:00 means 24 hours. If the settings is cross the day, for example: Start: 20:00 Stop: 10:00 means 00:00-10:00 am and 20:00-24:00 of the chosen day.

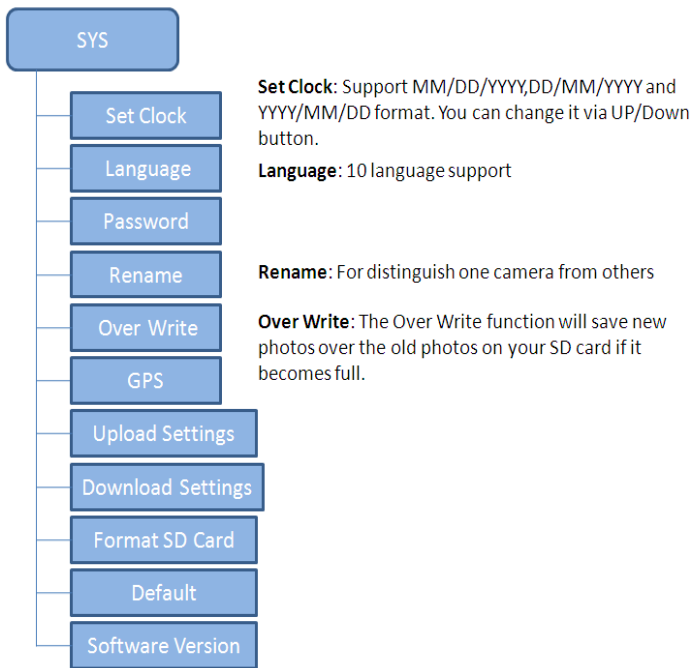

**Password:** Make sure you write down your password or save it to your mobile phone so you can access your camera if you ever forget your password.

## 2.7 Send a test photo

- 1) Switch camera to **Setup** mode, press ► button to take a picture, then press **OK** button to check this picture;
- 2) Press the **MENU** button, choose **send**. You will see sending progress shows on the LCD screen.



(Fig 4)

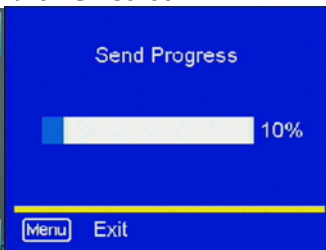

(Fig 5)

Once you see send successful, check your email account or phone see if you receive the correct photo.

If the sending is failure, choose **Diagnose** to generate a Log file and the FAQ will help you with your Log file.



(Fig 6)

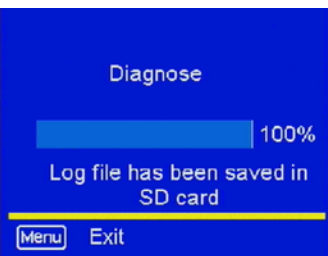

(Fig 7)

### **3 Connecting CAM to cloud server**

#### **3.1 Connecting CAM to cloud server**

In order to 'send' your photo to your cloud account or mobile phone, you need adding CAM towards them first Open website:

<https://cloud.firstcampro.com>

Login, if you already have an account, or simply register one with your email account.

Username/Email \*

Please enter username or email address.

Password \*

.....

Remember Me

**Log In**

---

[Forgot password?](#)

New users please [sign up](#) .

(Fig 8)

Username \*

Email \*

Email Address Verification Code \*

**Get Verification Code**

Set Password \*

Confirm Password \*

I agree to [Terms&Conditions](#)  
For existing accounts, please [LOG IN](#)

**Sign Up**

(Fig 9)

Click **'Add Device'**, a form will pop out requesting basic information for your CAM.



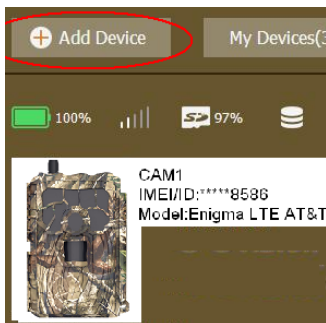

(Fig 10)



(Fig 11)

Name your CAM, and add location description if necessary, the SN and IMEI can be found labeled inside CAM.

### 3.2 Send a photo to cloud server

Choose a picture, press **MENU**, Select '**send**', the process of sending photo will present at screen, and within minutes your cloud account will receive your photos.



(Fig 12)

If the above test has accomplished, then you can slide **power switch** to '**on**' and start using it take photo or video automatically.

### 3.3 Setting CAM with Web Portal or APP

The CAM can be set up conveniently with cloud server and APP as well.

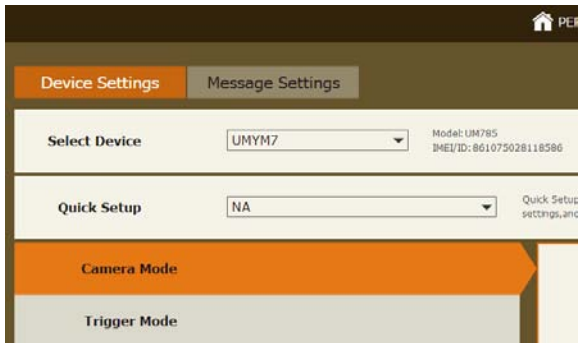

(Fig 13)

As to APP, Please search “firstcam”

The adding and setting process is quite similar to cloud server.

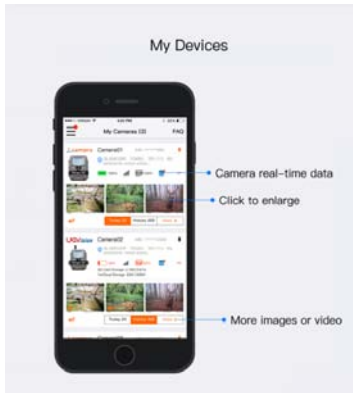

(Fig 14)

## 4 Auxiliary power

Your camera comes with an Auxiliary power jack. If you want to hook up an external 6V battery to power the camera, you can. The jack necessary to make the connection is a standard 4mm jack.

## 5 Mount tips

For best results, mount the camera approximately 1-1.5 meter off the ground and 3-15 meters. To enhance the flash, we recommend positioning the

camera in an area with a backdrop to reflect the maximum amount of light.

**Note:**

- a. **The sun should not be shining directly on the face of the camera.**

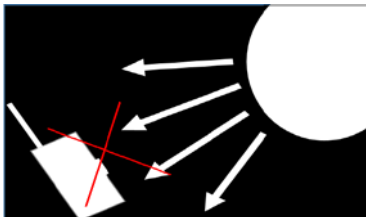

(Fig 15)

- b. **Reflect with trees or other things to add more light to your target.**

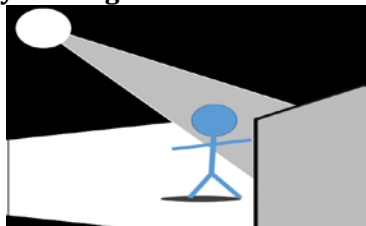

(Fig 16)

- c. **Avoid placing the camera where the air flow is surging or too much vegetation. False triggers**

**most occur on sunny, breezy days. When the wind moves the vegetation, the camera detects this and cannot distinguish it from a warm-blooded animal moving through the scene.**

## **Appendix I : Technical Specifications**

**Picture Resolution** 3/5/8/12MP

**Lens F/NO=1.85 FOV (Field of View)=58°**

**Frequency Bands:** FDD-LTE: B2/B4/B12;  
WCDMA: B2/B4/B5; GSM: Not supported;

**Flash Range** High, Low

**Display Screen** 2.0" LCD

**Memory Card** Up to 32GB

**Video Resolution** 1080P, 720P, WVGA

**PIR Sensor** Multi Zone

**PIR Sensitivity** Adjustable (High/Normal/Low)

**Trigger Time** 0.6s

**Trigger Interval** 5s – 60 min.

**Time lapse:** 3min-24hours

**Phase of Timer:** Four. Support work day  
choose

**Photo Burst** 1–10

**Video Length** 5–60s

**Power Supply** 12AA (Recommended);

6V/2A external power

**Stand-by Current** < 0.3 mA (<7mAh/Day)

**Power Consumption**

12AA batteries can transmit 3000+ VGA  
Photos

**Temperature reminder function :**

Support with cloud platform

**Low Battery Alert** LED Indicator, Cloud  
Platform

**Mounting** Rope/Belt/Python lock

**Dimensions** 4.68"X 3.39"X 2.43"

**Weight** 474g(without batteries)

**Operation Temp.** -20 - +60°C

**Operation Humidity** 5% - 90%

**Security authentication** FCC ID, AT&T



## Appendix II : Parts List

<b>Part Name</b>	<b>Quantity</b>
Digital Camera	One
Belt	One
User Manual	One
Quick Start	One

### **WARRANTY**

FirstCam Outdoor Inc. provides 12 months of warranty service for this product against manufacturing defects or malfunctions. If your camera fails to function under normal use within 1 year, we will repair or replace the camera at no charge. The purchase receipt must be included from an authorized retailer to validate the warranty. Improper use of the camera resulting in damage is not covered by this warranty. FirstCam Outdoor Inc. can provide repair service after the warranty expiration. In this case the customer will be

responsible for any charges on parts, labor and shipping costs. Please contact us for more details. Our complete warranty policy can be found on our website: [www.firstcam.pro](http://www.firstcam.pro)

## **FCC Statement**

This device complies with Part 15 of the FCC rules. Operation is subject to the following two conditions:  
1) this device may not cause harmful interference, and  
2) this device must accept any interference received, including interference that may cause undesired operation.

Note: This equipment has been tested and found to comply with the limits for a Class B digital device, pursuant to part 15 of the FCC Rules. These limits are designed to provide reasonable protection against harmful interference in a residential installation.

This equipment generates uses and can radiate radio frequency energy and, if not installed and used in accordance with the instructions, may cause harmful interference to radio communications.

However, there is no guarantee that interference will not occur in particular installation. If this equipment does cause harmful interference to radio or television reception, which can be determined by turning the equipment off and on, the user is encouraged to try to correct the

interference by one or more of the following measures:

- - Reorient or relocate the receiving antenna.
- - Increase the separation between the equipment and receiver.
- - Connect the equipment into an outlet on a circuit different from that to which the receiver is connected.
- - Consult the dealer or an experienced radio/TV technician for help.

Changes or modifications not expressly approved by the party responsible for compliance could void the user's authority to operate the equipment.

#### RF.Exposure Statement

This equipment complies with FCC radiation exposure limits set forth for an uncontrolled environment. This equipment normal use should be installed and operated with minimum distance 20cm between the radiator & your body.