

ROHS

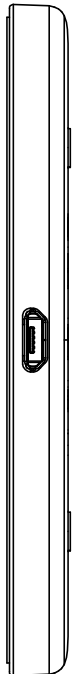

8.26±0.2

Ø87.47±0.1

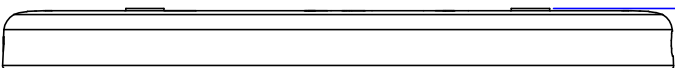

硅胶防滑垫面不允许有划伤、褶皱、气泡

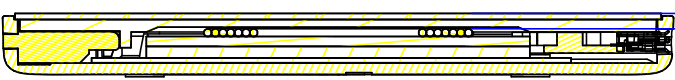
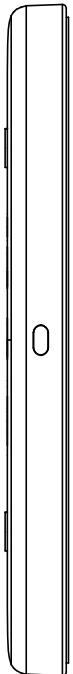

2-2.5 线圈顶面到无线充电顶面间距

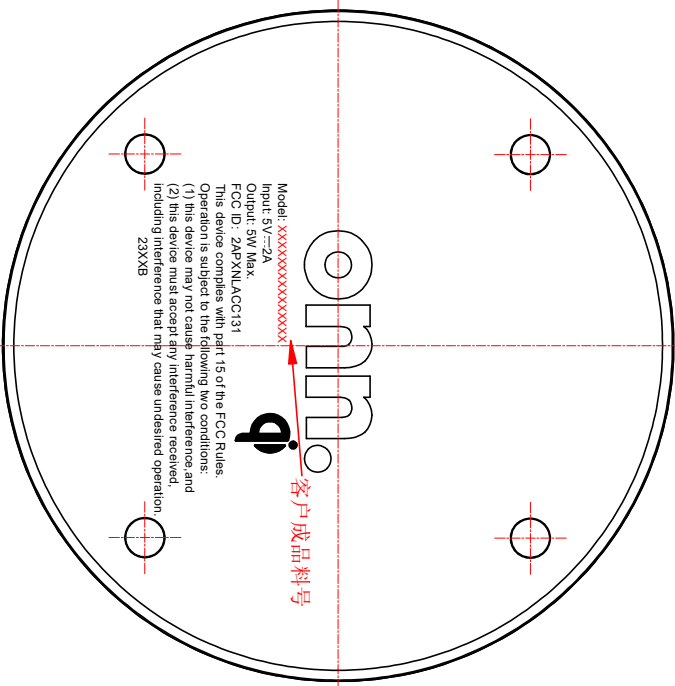

Model: XXXXXXXXXXXXXXXX
Input: 5V~2A
Output: 5W Max
FCC ID: 2APXNLA0C131
This device complies with part 15 of the FCC Rules.
Operation is subject to the following two conditions:
(1) This device may not cause harmful interference and
(2) This device must accept any interference received, including interference that may cause undesired operation.
23XX8

客户成品料号

| REV. | DESCRIPTION | DESIGN | APPROVAL | DATE |
|------|-------------|----------|------------|------------|
| A1 | NEW DRAWING | QIANG HE | XIONGWU LI | 2023.11.21 |

| 立讯成品料号 | 客户成品料号 | 颜色 |
|----------------|-----------------|-----|
| L3TWC409-CS-R1 | WIABLK100008472 | 丰富黑 |
| L3TWC411-CS-R1 | WIABLK100030362 | |
| L3TWC412-CS-R1 | WIAWHT100030217 | 北极白 |

| X.±1 | X.°±1 |
|------------|-----------|
| .X±0.3 | .X°±0.5 |
| .XX±0.20 | .XX°±0.3 |
| .XXX±0.100 | .XXX°±0.1 |
| UNITS: | mm |

| | | |
|----------------------|---------------------|--|
| Customer REV.: D87 | TITLE: LUXSHARE-ICT | |
| PART NO. | D87-5W无线充-硅胶 | |
| APPD: XIONGWU LI | DWG NO.* | |
| CHKD: SHUIPING ZHOU | | |
| Safety Eng: JUAN LUO | | |
| DRAW: QIANG HE | | |

| | | |
|-------|-------|------|
| SCALE | SHEET | REV. |
| 1:1 | 1/4 | A1 |

THESE DRAWINGS AND SPECIFICATIONS ARE THE PROPERTY OF LUXSHARE-ICT AND SHALL NOT BE REPRODUCED, COPIED OR CUED IN ANY MANNER WITHOUT THE PRIOR WRITTEN CONSENT OF LUXSHARE-ICT

ROHS

技术要求:

1.工艺:移印

2.2:1视图尺寸

omni^oqi

Model: WIABLK100008472

Input: 5V \rightarrow 2A

Output: 5W Max.

FCC ID: 2APXNLACC131

This device complies with part 15 of the FCC Rules.

Operation is subject to the following two conditions:

(1) this device may not cause harmful interference, and

(2) this device must accept any interference received, including interference that may cause undesired operation.

23XXB

3. 颜色: PANTONE430C字体为Arial 字高为1.2

4. 镭雕: 23XXB

工厂代码
生产周别
生产年份

注: 周别按生产的周别变动而变动 无线充, 彩盒镭雕一致

例: 2301B

2302B

2303B

以此类推

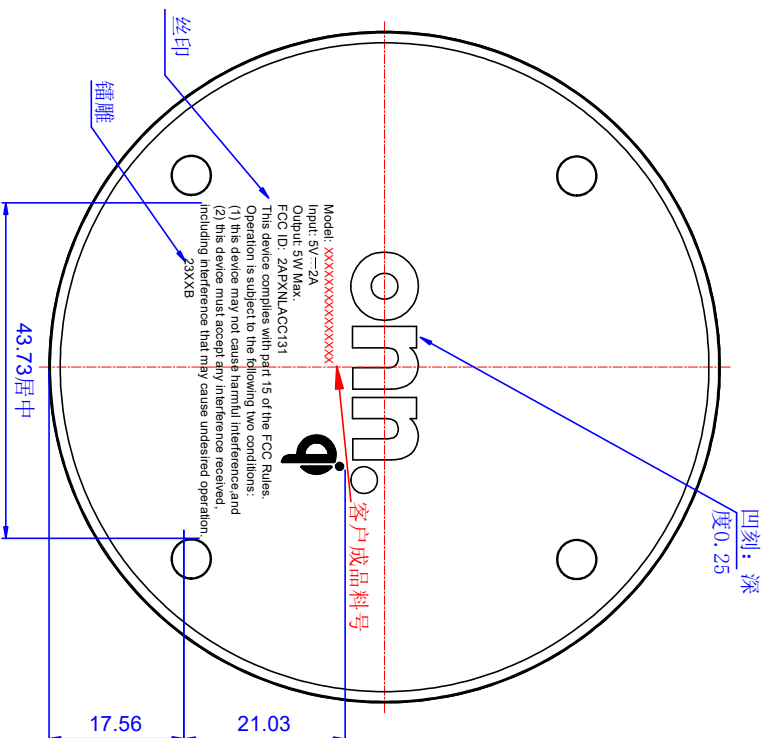

| 立讯成品料号 | 客户成品料号 | 颜色 |
|----------------|-----------------|-----|
| L3TWC409-CS-R1 | WIABLK100008472 | 丰富黑 |
| L3TWC411-CS-R1 | WIABLK100030362 | |
| L3TWC412-CS-R1 | WIAWHT100030217 | 北极白 |

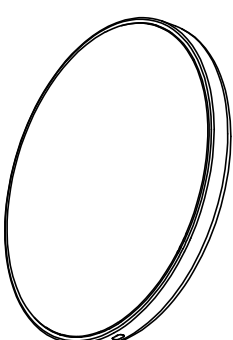

| | |
|------------------|------------------------|
| X \pm 1 | X \circ \pm 1 |
| .X \pm 0.3 | .X \circ \pm 0.5 |
| .XX \pm 0.20 | .XX \circ \pm 0.3 |
| .XXX \pm 0.100 | .XXX \circ \pm 0.1 |
| UNITS: | mm |

Customer REV.: D87

PART NO.

APPD: XIONGWU LI

CHKD: SHUIPING ZHOU

Safety Eng: JUAN LUO

DRAW: QIANG HE

LUXSHARE-ICT

TITLE: D87-5W无线充-硅胶

DWG NO.*



SCALE SHEET REV.

1:1 2/4 A1

A

B

C

D

E

8

7

6

5

4

3

2

1

8

7

6

5

4

3

2

1

A

B

C

D

E

ROHS

| 立讯成品料号 | 客户成品料号 | 颜色 |
|----------------|-----------------|-----|
| L3TWC409-CS-R1 | WIABLK100008472 | 丰富黑 |
| L3TWC411-CS-R1 | WIABLK100030362 | 丰富黑 |
| L3TWC412-CS-R1 | WIAWHT100030217 | 北极白 |

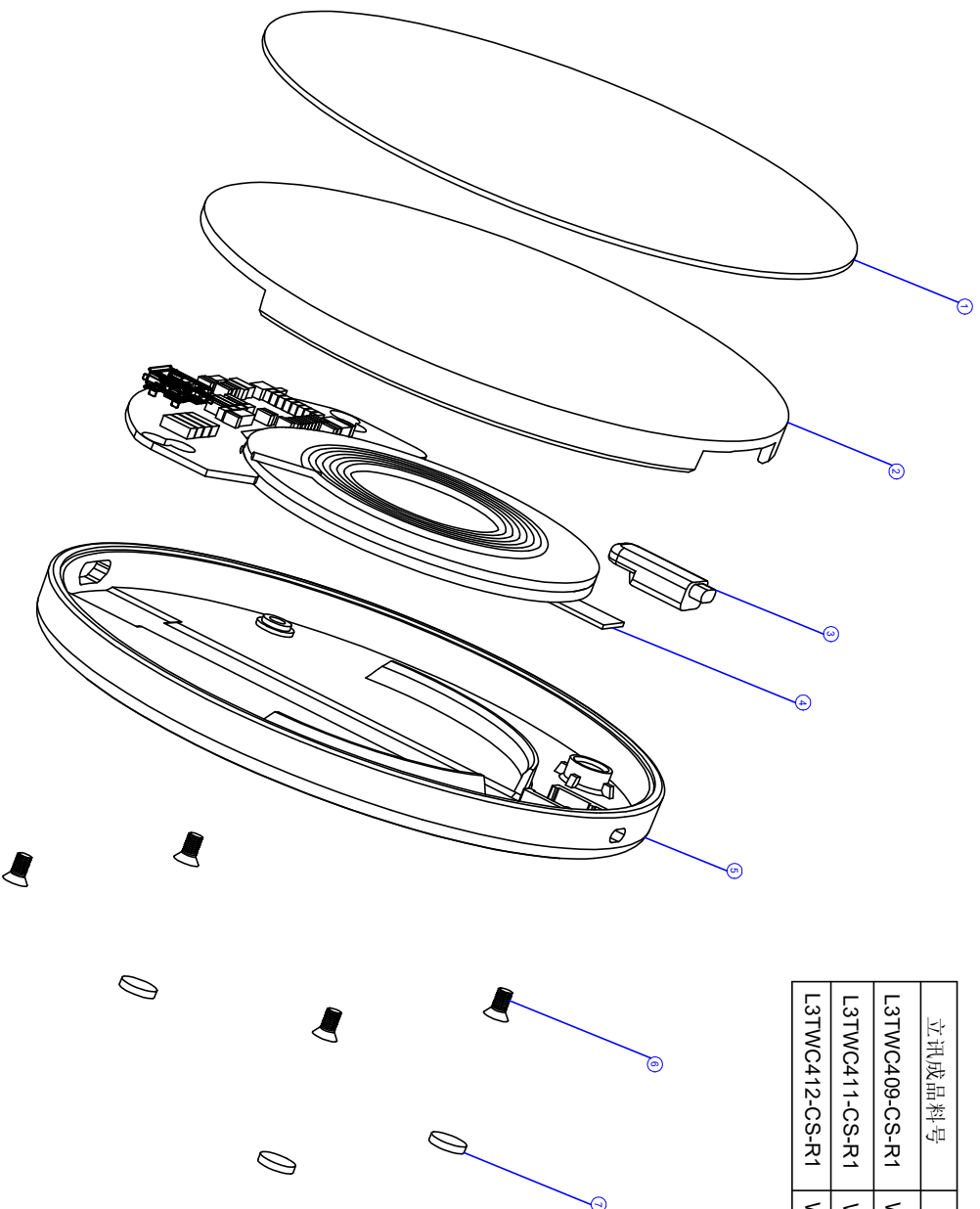

| ITEM | NAME | DESCRIPTION | QTY | UNIT |
|------|------|--|-----|------|
| ⑦ | 脚垫 | 脚垫,ODXH=5.0x1.0mm,Silicone,Black,背面背胶,ROHS 2.0 | 4 | pcs |
| ⑥ | 螺丝 | *螺丝-C1010-F-B-+-镀锌-M2.0*5.0-HF | 4 | pcs |
| ⑤ | 下盖 | 塑壳-无线充-下盖-PC-V0-87.51*7.66-雾面-11P (MT-1055-3),丝印,11P Free | 1 | pcs |
| ④ | PCBA | LAOC131 AC Wireless charger 5W BPP 主板/小板 (SMT) | 1 | pcs |
| ③ | 导光柱 | 塑壳-导光柱-PC-半透明-V0-15*6*4.1-雾面-11P | 1 | pcs |
| ② | 上盖 | 塑壳-无线充-上盖-PC-V0-83*5.06-11P | 1 | pcs |
| ① | 防滑垫 | *硅胶件-防滑垫-圆形-黑色-84.2*0.8-背3M胶-R | 1 | pcs |

| X.±1 | X.°±1 |
|-------------|-----------|
| .XX±0.3 | .X°±0.5 |
| .XXX±0.20 | .XX°±0.3 |
| .XXXX±0.100 | .XXX°±0.1 |

| | |
|----------------------|---------------------|
| Customer REV.: D87 | LUXSHARE-ICT |
| PART NO. | |
| APPD: XIONGWU LI | DWG NO.* |
| CHKD: SHUJING ZHOU | |
| Safety Eng: JUAN LUO | |
| DRAW: QIANG HE | |

THESE DRAWINGS AND SPECIFICATIONS ARE THE PROPERTY OF LUXSHARE-ICT AND SHALL NOT BE REPRODUCED, COPIED OR CUED IN ANY MANNER WITHOUT THE PRIOR WRITTEN CONSENT OF LUXSHARE-ICT

| | | | |
|---------------------|-------|-------|------|
| TITLE: D87-5W无线充-硅胶 | SCALE | SHEET | REV. |
| | 1:1 | 3/4 | A1 |

ROHS

NOTES:(注解)

- Appearance shall be inspected in accordance with the 《AEGW-QA-012 Charger finished product inspection standard》 and the content should comply with drawing. 外观依《AEGW-QA-012 Charger成品检验标准》检验、内容应符合图纸。
- Mechanical Test(机械测试):
 - Unit drop: falls freely on the cement floor at the height of 100cm, once each surface, 6 times, no cracking on enclosure, no electrical failure. 单体跌落:高度100cm自由跌落于水泥地板, 每个面一次, 跌落6次,外壳无开裂, 电性正常
 - Tumbling test: 200 times from the height of 50 cm, 15times/Min. After the test, the housing has no crack and the electrical function keeps normal. 滚筒测试:高度50cm, 200次, 15次/min,外壳无开裂, 电性正常
 - Micro-USB insertion and withdrawal durability: at the speed of 200 times/H, 10000 times of extraction and insertion, one time back and forth. After the test, the electrical function of the product is normal, and the extraction force before and after the test is no less than 8N. Micro-USD 插拔耐久:以速度200次/H, 拔插10000次,来回算一次,测试后产品电性接触正常, 测试前后拔出力不小于8N
- Environmental test(环境测试):
 - Inner box or color box for high and low temperature storage: keep the temperature at -40℃ for 23 minutes, and then keep it is 85℃ for 23 minutes, go through 50 cycles, placed at room temperature for 1H, the product can work normally, and have no appearance defect such as enclosure melting. 内箱或彩盒高低温存储:环境温度-40℃/23分钟, 温度85℃/23分钟, 循环50个周期, 常温放置1H, 产品通电可以正常工作及不允许出现外壳溶胶等外观不良。
 - High temperature and humidity: Temperature 85℃, humidity 85%, input voltage 5VDC, output no-load, work for 72H, the product can work normally, it is not allowed to have appearance defects such as enclosure melting. 高温高湿:温度85℃, 湿度85%, 输入电压5VDC、输出空载, 工作72H, 产品通电可以正常工作, 不允许现外壳溶胶等外观不良。
 - High low temperature work: input voltage 5VDC, temperature range at -10℃~40℃, keep at hightemperature and low temperature each for 20min, total 36 cycles. 高低温工作:温度变化范围-10℃~40℃, 输入电压5VDC、输出满载, 高低温各保持20min, 共进行36个循环。
 - Foreign object detection: under the condition of 5Vdc and 9Vdc input, the product will stop charging after the foreign object is placed in the wireless charging area 异物检测:输入在5VDC条件下,无线充电区域放入异物后, 产品停止充电
 - Limit charging distance(极限充电距离): Coil surface to wireless charging surface 3mm Max. The shell thickness of the mobile device is 5mm Max, and the product can supply power normally 线圈表面至无线充电表面2mm Max;移动设备外壳厚度5mm Max, 产品能正常供电
 - Salt spray test: the sodium chloride solution with a concentration of 5% is automatically sprayed for 24 hours after the salt spray test, and the test is started after placed 4H at room temperature. After the test, clean it with clean water and let it dry naturally, there should be no corrosion, rust or other abnormal phenomena. 盐雾测试:5%浓度的氯化钠溶液经盐雾试验自动喷雾24小时, 室温放置4H后开始检测。测试完成后用清水清洗, 自然晾干无腐蚀, 生锈等异常现象
 - Enclosure temperature rise: under the condition of 5VDC, output with full load, ambient temperature of 25℃±3℃, non-enclosure temperature rise should be less than 50℃, metal enclosure temperature rise should be less than 30℃

外壳温升: 输入在5VDC条件下,输出带满载, 环境温度25℃±3℃, 外壳温升小于30℃

8.Tilt test: place the wireless charging product on a plane with a horizontal tilt of 8°, and the mobile phone or other equipment charged on the wireless charging cannot slide down, but can still maintain the original position for charging. 倾斜测试: 将无线充电产品放在一个水平倾斜8°的平面上, 在无线充电的手机或者其它设备不能滑落, 仍能保持原来的位置进行充电。

9.Electrical test project shall be implemented in accordance with 《L3TWC412-CS-R-US》 product specification;

电气测试项目依照《L3TWC412-CS-R-US 产品规格书》执行

10.Aging test(老化测试):

DC 5V input, full load aging, temperature 25℃, aging time 2H, according to the specification to determine the performance 直流5V输入,满载老化,在温度25℃,老化时间2H,依照规格书判定性能

11.DIMENSIONS MARKED  SHALL BE CHECKED.

標有  的尺寸必須重點檢驗

12.ALL APPLICABLE MATERIALS AND PROCESS CONTROL MUST BE IN COMPLIANCE WITH DOCUMENT QW-Q-043 -ROHS2.0

本产品所用物料及制程必须符合:QW-Q-043环境物质管理规定-ROHS2.0

Note: 2.2/2.3 and 3 environmental test requirements should keep in accordance with the reliability frequency requirements

注: 2.2/2.3及第三点环境测试要求依照信赖性频率要求测试

| 规格 | 项目 | 规格指标 |
|----------|---------|-------|
| DC输入特性 | 输入电压范围 | 5V |
| | 输入电流 | 2A |
| 无线充电输出特性 | 输出电压/电流 | 5V-1A |
| | 输出功率 | 5W |

| 立讯成品料号 | 客户成品料号 | 颜色 |
|----------------|-----------------|-----|
| L3TWC409-CS-R1 | W/ABLK100008472 | 丰富黑 |
| L3TWC411-CS-R1 | W/ABLK100030362 | |
| L3TWC412-CS-R1 | W/AWHT100030217 | 北极白 |

| X.±1 | X.°±1 |
|-------------|-----------|
| .X± 0.3 | .X°±0.5 |
| .XX± 0.20 | .XX°±0.3 |
| .XXX± 0.100 | .XXX°±0.1 |

| | |
|----------------------|---------------------|
| Customer REV.: D87 | PART NO. |
| APPD: XIONGWU LI | CHKD: SHUIPING ZHOU |
| Safety Eng: JUAN LUO | DRAW: QIANG HE |

| | |
|---------------------|------------------|
| TITLE: LUXSHARE-ICT | |
| D87-5W无线充-硅胶 | |
| DWG NO.* | SCALE SHEET REV. |
| | 1:1 4/4 A1 |

THESE DRAWINGS AND SPECIFICATIONS ARE THE PROPERTY OF LUXSHARE-ICT AND SHALL NOT BE REPRODUCED, COPIED OR QUED IN ANY MANNER WITHOUT THE PRIOR WRITTEN CONSENT OF LUXSHARE-ICT

| | |
|----------------------|---------------------|
| APPD: XIONGWU LI | CHKD: SHUIPING ZHOU |
| Safety Eng: JUAN LUO | DRAW: QIANG HE |

| | |
|----------|------------------|
| DWG NO.* | SCALE SHEET REV. |
| | 1:1 4/4 A1 |