

TEST REPORT

Application No.: SHEM2008006846CR
FCC ID: 2APV2-CSW2DAPC
Applicant: Hangzhou Ezviz Software Co., Ltd.
Address of Applicant: Room 302,Unit B,Building 2,399 Danfeng Road,Binjiang District, Hangzhou, Zhejiang
Manufacturer: Hangzhou Ezviz Software Co., Ltd.
Address of Manufacturer: Room 302,Unit B,Building 2,399 Danfeng Road,Binjiang District, Hangzhou, Zhejiang
Equipment Under Test (EUT):
EUT Name: Wire-Free Camera Base Station
Model No.: CS-W2D
Standard(s) : 47 CFR Part 15, Subpart C 15.231
Date of Receipt: 2020-08-25
Date of Test: 2020-08-25 to 2020-08-28
Date of Issue: 2020-09-10

Test Result:	Pass*
---------------------	--------------

* In the configuration tested, the EUT complied with the standards specified above.

Parlam Zhan

Parlam Zhan
E&E Section Manager

The manufacturer should ensure that all products in series production are in conformity with the product sample detailed in this report. If the product in this report is used in any configuration other than that detailed in the report, the manufacturer must ensure the new system complies with all relevant standards. Any mention of SGS International Electrical Approvals or testing done by SGS International Electrical Approvals in connection with, distribution or use of the product described in this report must be approved by SGS International Electrical Approvals in writing.



Unless otherwise agreed in writing, this document is issued by the Company subject to its General Conditions of Service printed overleaf, available on request or accessible at <http://www.sgs.com/en/Terms-and-Conditions.aspx> and, for electronic format documents, subject to Terms and Conditions for Electronic Documents at <http://www.sgs.com/en/Terms-and-Conditions/Terms-e-Documents.aspx>. Attention is drawn to the limitation of liability, indemnification and jurisdiction issues defined therein. Any holder of this document is advised that information contained hereon reflects the Company's findings at the time of its intervention only and within the limits of Client's instructions, if any. The Company's sole responsibility is to its Client and this document does not exonerate parties to a transaction from exercising all their rights and obligations under the transaction documents. This document cannot be reproduced except in full, without prior written approval of the Company. Any unauthorized alteration, forgery or falsification of the content or appearance of this document is unlawful and offenders may be prosecuted to the fullest extent of the law. Unless otherwise stated the results shown in this test report refer only to the sample(s) tested and such sample(s) are retained for 30 days only.

Attention: To check the authenticity of testing /inspection report & certificate, please contact us at telephone: (86-755) 8307 1443, or email: CN.Doccheck@sgs.com



Revision Record			
Version	Description	Date	Remark
00	Original	2020-09-10	/

Authorized for issue by:			
			
		<hr/>	
		Micheal Niu / Project Engineer	
			
		<hr/>	
		Parlam Zhan / Reviewer	



2 Test Summary

Test Item	FCC Requirement	Test method	Result
Antenna Requirement	Part 15.203	/	PASS
Conducted Emission	Part 15.207	ANSI C63.10 (2013) Section 6.2	N/A
Field Strength of the Fundamental	Part 15.231 (b)	ANSI C63.10 (2013) Section 6.4	PASS
Radiated Spurious emissions	Part 15.209 15.231(b)	ANSI C63.10 (2013) Section 6.4&6.5&6.6	PASS
20dB Bandwidth	Part 15.231 (c)	ANSI C63.10 (2013) Section 6.9.2	PASS
Dwell Time	Part 15.231 (a)	ANSI C63.10 (2013) Section 7.8.4	PASS



3 Contents

	Page
1 COVER PAGE	1
2 TEST SUMMARY.....	3
3 CONTENTS.....	4
4 GENERAL INFORMATION	5
4.1 DETAILS OF E.U.T.	5
4.2 DESCRIPTION OF SUPPORT UNITS.....	5
4.3 MEASUREMENT UNCERTAINTY	5
4.4 TEST LOCATION	6
4.5 TEST FACILITY	6
4.6 DEVIATION FROM STANDARDS	6
4.7 ABNORMALITIES FROM STANDARD CONDITIONS.....	6
5 EQUIPMENT LIST	7
6 RADIO SPECTRUM TECHNICAL REQUIREMENT	8
6.1 ANTENNA REQUIREMENT.....	8
7 RADIO SPECTRUM MATTER TEST RESULTS	9
7.1 CONDUCTED EMISSIONS AT AC POWER LINE (150kHz-30MHz).....	9
7.2 20DB BANDWIDTH.....	13
7.3 DWELL TIME	15
7.4 FIELD STRENGTH OF THE FUNDAMENTAL SIGNAL (15.231(B)).....	17
7.5 RADIATED EMISSIONS	20
8 TEST SETUP PHOTOGRAPHS.....	26
9 EUT CONSTRUCTIONAL DETAILS.....	26

4 General Information

4.1 Details of E.U.T.

Power supply: DC 5V by Adapter
 Operation Frequency 433.3MHz
 Modulation Technique: ASK
 Antenna Type: PIFA Antenna
 Number of Channel: 1

4.2 Description of Support Units

Description	Manufacturer	Model No.	Serial No.
AC Adapter	Apple	A1402	/
Laptop	Lenovo	ThinkPad X100e	/
SecureCRT	VanDyke	V 6.2.0	/
Serial port adapter plate	/	Test Plate 3	/

4.3 Measurement Uncertainty

No.	Item	Measurement Uncertainty
1	Radio Frequency	8.4×10^{-8}
2	Timeout	2s
3	Duty Cycle	0.37%
4	Occupied Bandwidth	3%
5	RF Conducted Power	0.6dB
6	RF Power Density	2.9dB
7	Conducted Spurious Emissions	0.75dB
8	RF Radiated Power	5.1dB (Below 1GHz)
		4.9dB (Above 1GHz)
9	Radiated Spurious Emission Test	4.2dB (Below 30MHz)
		4.5dB (30MHz-1GHz)
		5.1dB (1GHz-18GHz)
		5.4dB (Above 18GHz)
10	Temperature Test	1°C
11	Humidity Test	3%
12	Supply Voltages	1.5%
13	Time	3%

Note: The measurement uncertainty represents an expanded uncertainty expressed at approximately the 95% confidence level using a coverage factor of k=2.

4.4 Test Location

All tests were performed at:

Compliance Certification Services (Kunshan) Inc.

No.10 Weiye Rd, Innovation park, Eco&Tec, Development Zone, Kunshan City, Jiangsu, China.

Tel: +86 512 5735 5888 Fax: +86 512 5737 0818

No tests were sub-contracted.

4.5 Test Facility

The test facility is recognized, certified, or accredited by the following organizations:

- **CNAS (No. CNAS L4354)**

CNAS has accredited Compliance Certification Services (Kunshan) Inc. to ISO/IEC 17025:2017 General Requirements for the Competence of Testing and Calibration Laboratories (CNAS-CL01 Accreditation Criteria for the Competence of Testing and Calibration Laboratories) for the competence in the field of testing.

- **A2LA (Certificate No. 2541.01)**

Compliance Certification Services (Kunshan) Inc. is accredited by the American Association for Laboratory Accreditation (A2LA). Certificate No. 2541.01.

- **FCC (Designation Number: CN1172)**

Compliance Certification Services Inc. has been recognized as an accredited testing laboratory. Designation Number: CN1172.

- **ISED (CAB identifier: CN0072)**

Compliance Certification Services (Kunshan) Inc. has been recognized by Innovation, Science and Economic Development Canada (ISED) as an accredited testing laboratory.

CAB Identifier: CN0072.

- **VCCI (Member No.: 1938)**

The 3m and 10m Semi-anechoic chamber and Shielded Room of Compliance Certification Services (Kunshan) Inc. has been registered in accordance with the Regulations for Voluntary Control Measures with Registration No.: R-1600, C-1707, T-1499, G-10216 respectively.

4.6 Deviation from Standards

None

4.7 Abnormalities from Standard Conditions

None



5 Equipment List

Item	Equipment	Manufacturer	Model	Serial Number	Cal Date	Cal. Due Date
Conducted Emission at Mains Terminals (150kHz-30MHz)						
1	EMI Test Receive	R&S	ESCI	100781	02/24/2020	02/23/2021
2	LISN	R&S	ENV216	101604	10/24/2019	10/23/2020
3	LISN	Schwarzbeck	NNLK 8129	8129-143	10/24/2019	10/23/2020
4	Pulse Limiter	R&S	ESH3-Z2	100609	02/24/2020	02/23/2021
5	CE test Cable	Thermax	/	14	02/24/2020	02/23/2021
RF Conducted Test						
1	Spectrum Analyzer	Agilent	E4446A	MY44020154	04/22/2020	04/21/2021
2	Spectrum Analyzer	Keysight	N9020A	MY55370209	12/19/2019	12/18/2020
3	Signal Generator	Agilent	E8257C	MY43321570	10/24/2019	10/23/2020
4	Vector Signal Generator	R&S	SMU 200A	102744	02/24/2020	02/23/2021
5	Universal Radio Communication Tester	R&S	CMU200	109525	12/19/2019	12/18/2020
6	Universal Radio Communication Tester	R&S	CMW500	159275	12/19/2019	12/18/2020
7	Power Meter	Anritsu	ML2495A	1445010	04/21/2020	04/20/2021
8	Switcher	CCSRF	FY562	KS301219	12/20/2019	12/19/2020
9	AC Power Source	EXTECH	6605	1570106	N.C.R	N.C.R
10	DC Power Supply	Agilent	E3632A	MY50340053	N.C.R	N.C.R
11	6dB Attenuator	Mini-Circuits	NAT-6-2W	15542-1	N.C.R	N.C.R
12	Power Divider	AISI	IOWOPE2068	PE2068	N.C.R	N.C.R
13	Filter	MICRO-TRONICS	BRM50701	5	N.C.R	N.C.R
14	Conducted test cable	/	RF01-RF04	/	04/21/2020	04/22/2021
15	Temp. / Humidity Chamber	TERCHY	MHK-120AK	X30109	04/21/2020	04/20/2021
RF Radiated Test						
1	Spectrum Analyzer	R&S	FSV40	101493	01/08/2020	01/07/2021
2	Signal Generator	Agilent	E8257C	MY43321570	10/24/2019	10/23/2020
3	Loop Antenna	Schwarzbeck	HXYZ9170	9170-108	02/24/2020	02/23/2021
4	Bilog Antenna	TESEQ	CBL 6112D	35403	06/22/2019	06/21/2021
5	Bilog Antenna	SCHWARZBECK	VULB9160	9160-3342	04/29/2019	04/28/2021
6	Horn-antenna(1-18GHz)	Schwarzbeck	BBHA9120D	267	11/04/2018	11/03/2020
7	Horn-antenna(1-18GHz)	ETS-LINDGREN	3117	00143290	02/25/2019	02/24/2021
8	Horn Antenna(18-40GHz)	Schwarzbeck	BBHA9170	BBHA9170171	02/27/2018	02/26/2021
9	Pre-Amplifier(30MHz~18GHz)	CCSRF	AMP1277	1	12/19/2019	12/18/2020
10	Pre-Amplifier(0.1~26.5GHz)	EMCI	EMC012645	980060	04/21/2020	04/20/2021
11	Low Pass Filter	MICRO-TRONICS	VLFX-950	RV142900829	N.C.R	N.C.R
12	High Pass Filter	Mini-Circuits	VHF-1200	15542	N.C.R	N.C.R
13	Filter (5450MHz~5770 MHz)	MICRO-TRONICS	BRC50704-01	2	N.C.R	N.C.R
14	Filter (5690 MHz~5930 MHz)	MICRO-TRONICS	BRC50705-01	4	N.C.R	N.C.R
15	Filter (5150 MHz~5350 MHz)	MICRO-TRONICS	BRC50703-01	2	N.C.R	N.C.R
16	Filter (885 MHz~915 MHz)	MICRO-TRONICS	BRM14698	1	N.C.R	N.C.R
17	Filter (815 MHz~860 MHz)	MICRO-TRONICS	BRM14697	1	N.C.R	N.C.R
18	Filter (1745 MHz~1910 MHz)	MICRO-TRONICS	BRM14700	1	N.C.R	N.C.R
19	Filter (1922 MHz~1977 MHz)	MICRO-TRONICS	BRM50715	1	N.C.R	N.C.R
20	Filter (2550 MHz)	MICRO-TRONICS	HPM13362	5	N.C.R	N.C.R
21	Filter (1532 MHz~1845 MHz)	MICRO-TRONICS	BRM50713	1	N.C.R	N.C.R
22	Filter (2.4GHz)	MICRO-TRONICS	BRM50701	5	N.C.R	N.C.R
23	RE test cable	/	RE01-RE04	/	04/21/2020	04/22/2021



6 Radio Spectrum Technical Requirement

6.1 Antenna Requirement

6.1.1 Test Requirement:

47 CFR Part 15, Subpart C 15.203

6.1.2 Conclusion

Standard Requirement:

An intentional radiator shall be designed to ensure that no antenna other than that furnished by the responsible party shall be used with the device. The use of a antenna that uses a unique coupling to the intentional radiator, the manufacturer may design the unit permanently attached antenna or of an so that a broken antenna can be replaced by the user, but the use of a standard antenna jack or electrical connector is prohibited.

EUT Antenna:

The antenna is PIFA antenna and no consideration of replacement.

Antenna location: Refer to Appendix(Internal Photos)

7 Radio Spectrum Matter Test Results

7.1 Conducted Emissions at AC Power Line (150kHz-30MHz)

Test Requirement 47 CFR Part 15, Subpart C 15.207

Test Method: ANSI C63.10 (2013) Section 6.2

Limit:

Frequency of emission(MHz)	Conducted limit(dB μ V)	
	Quasi-peak	Average
0.15-0.5	66 to 56*	56 to 46*
0.5-5	56	46
5-30	60	50

*Decreases with the logarithm of the frequency.

7.1.1 E.U.T. Operation

Operating Environment:

Temperature: 22 °C Humidity: 50 % RH Atmospheric Pressure: 1020 mbar

Test mode b: TX mode_Keep the EUT in transmitting with modulation mode.

7.1.2 Test Setup Diagram

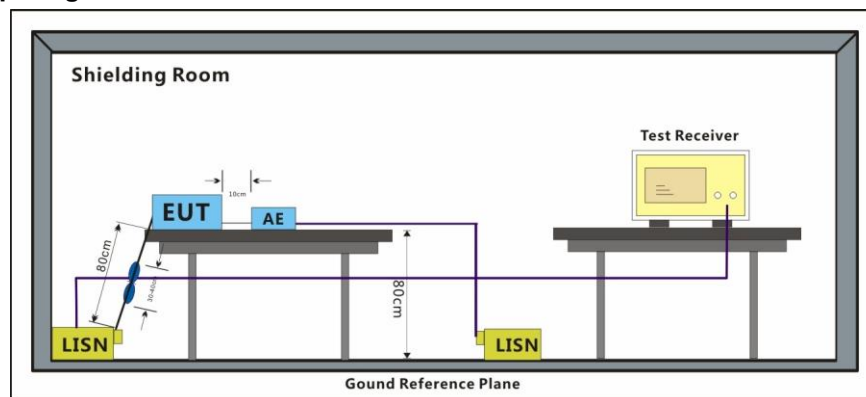

7.1.3 Measurement Procedure and Data

- 1) The mains terminal disturbance voltage test was conducted in a shielded room.
- 2) The EUT was connected to AC power source through a LISN 1 (Line Impedance Stabilization Network) which provides a 50ohm/50 μ H + 5ohm linear impedance. The power cables of all other units of the EUT were connected to a second LISN 2, which was bonded to the ground reference plane in the same way as the LISN 1 for the unit being measured. A multiple socket outlet strip was used to connect multiple power cables to a single LISN provided the rating of the LISN was not exceeded.
- 3) The tabletop EUT was placed upon a non-metallic table 0.8m above the ground reference plane. And for floor-standing arrangement, the EUT was placed on the horizontal ground reference plane,
- 4) The test was performed with a vertical ground reference plane. The rear of the EUT shall be 0.4 m from the vertical ground reference plane. The vertical ground reference plane was bonded to the horizontal ground reference plane. The LISN 1 was placed 0.8 m from the boundary of the unit under test and bonded to a ground reference plane for LISNs mounted on top of the ground reference plane. This distance was between the closest points of the LISN 1 and the EUT. All other units of the EUT and associated equipment was at least 0.8 m from the LISN 2.
- 5) In order to find the maximum emission, the relative positions of equipment and all of the interface cables must be changed according to ANSI C63.10 on conducted measurement.

Remark: LISN=Read Level+ Cable Loss+ LISN Factor

Mode:b; Line:Live Line

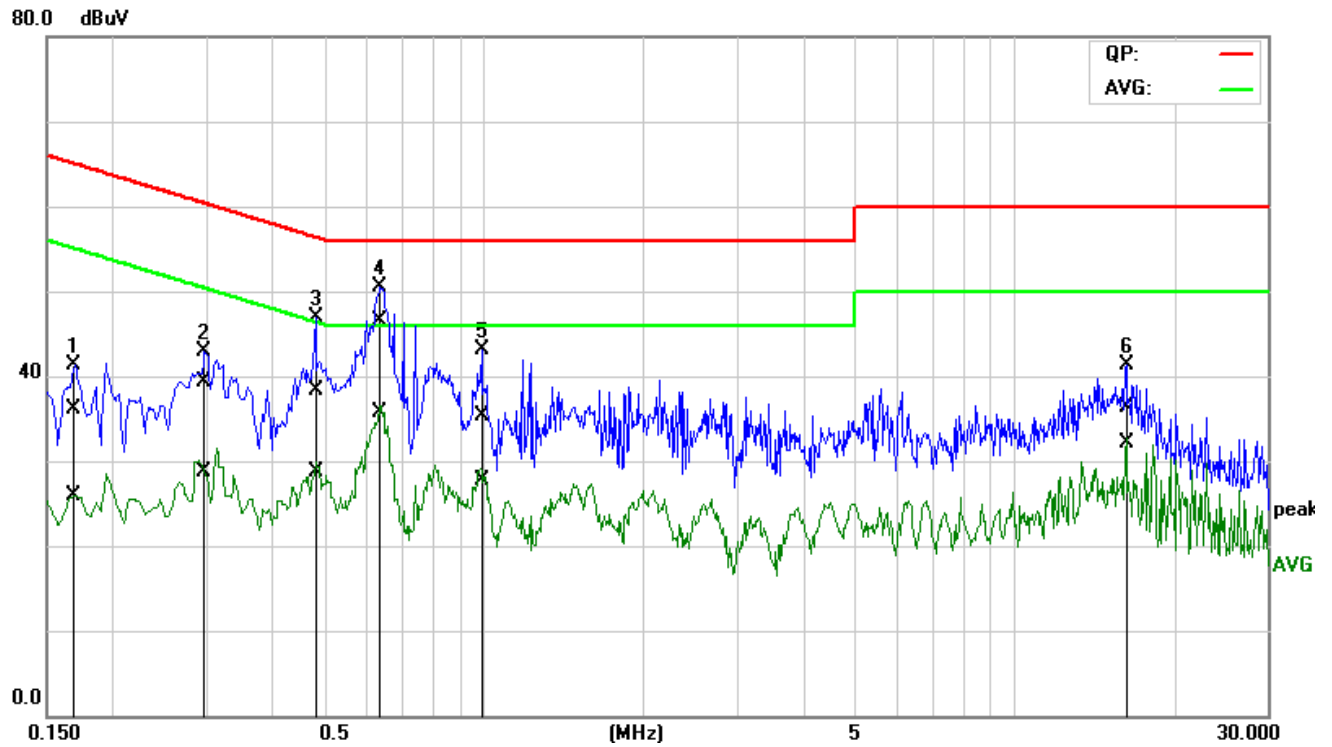

No.	Frequency (MHz)	QuasiPeak reading (dBuV)	Average reading (dBuV)	Correction factor (dB)	QuasiPeak result (dBuV)	Average result (dBuV)	QuasiPeak limit (dBuV)	Average limit (dBuV)	QuasiPeak margin (dB)	Average margin (dB)	Remark
1	0.1686	16.74	6.47	19.44	36.18	25.91	65.03	55.03	-28.85	-29.12	Pass
2	0.2972	19.99	9.33	19.38	39.37	28.71	60.32	50.32	-20.95	-21.61	Pass
3	0.4810	18.91	9.31	19.46	38.37	28.77	56.32	46.32	-17.95	-17.55	Pass
4*	0.6379	27.12	16.19	19.48	46.60	35.67	56.00	46.00	-9.40	-10.33	Pass
5	0.9980	15.67	8.13	19.58	35.25	27.71	56.00	46.00	-20.75	-18.29	Pass
6	16.2278	16.14	11.94	20.20	36.34	32.14	60.00	50.00	-23.66	-17.86	Pass

Mode:b; Line:Neutral Line

80.0 dBuV

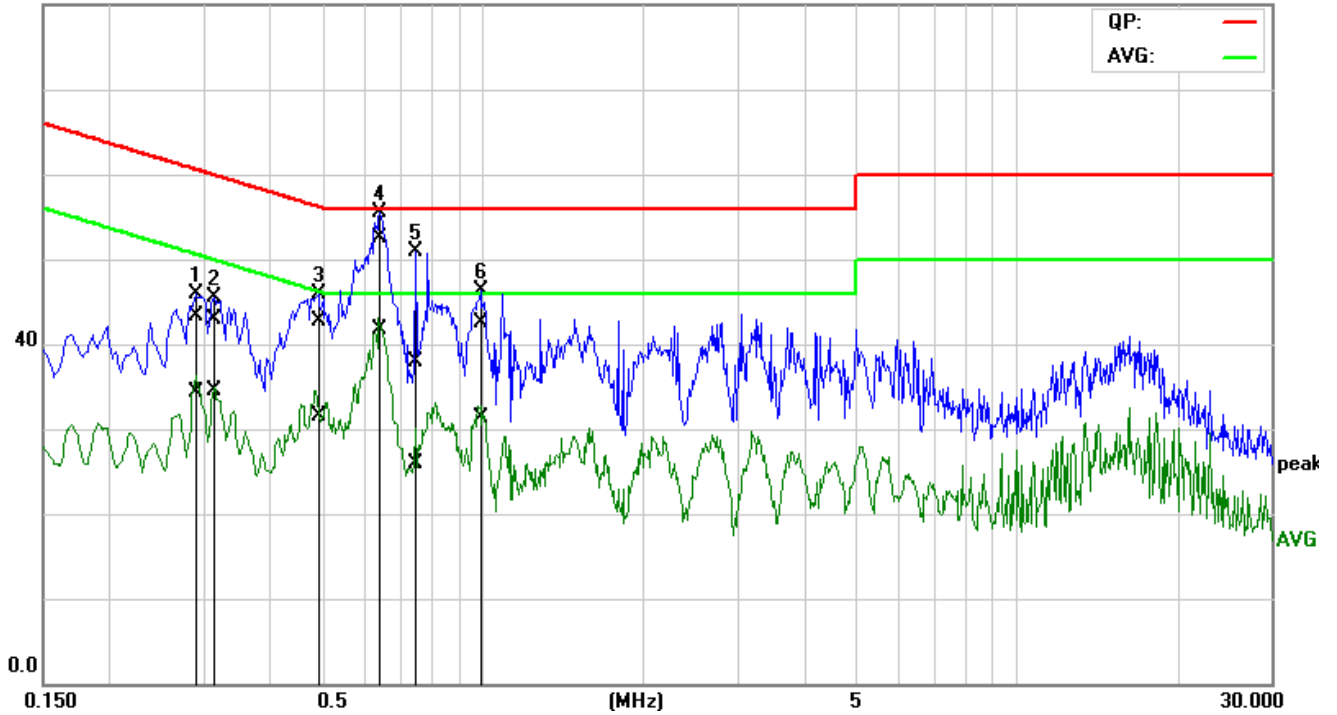

No.	Frequency	QuasiPeak reading	Average reading	Correction factor	QuasiPeak result	Average result	QuasiPeak limit	Average limit	QuasiPeak margin	Average margin	Remark
	(MHz)	(dBuV)	(dBuV)	(dB)	(dBuV)	(dBuV)	(dBuV)	(dBuV)	(dB)	(dB)	
1	0.2885	23.98	14.98	19.38	43.36	34.36	60.57	50.57	-17.21	-16.21	Pass
2	0.3132	23.52	15.08	19.38	42.90	34.46	59.89	49.89	-16.99	-15.43	Pass
3	0.4947	23.40	12.08	19.39	42.79	31.47	56.09	46.09	-13.30	-14.62	Pass
4*	0.6403	33.14	22.36	19.44	52.58	41.80	56.00	46.00	-3.42	-4.20	Pass
5	0.7511	18.36	6.38	19.48	37.84	25.86	56.00	46.00	-18.16	-20.14	Pass
6	0.9860	22.86	11.67	19.56	42.42	31.23	56.00	46.00	-13.58	-14.77	Pass

7.2 20dB Bandwidth

Test Requirement 47 CFR Part 15, Subpart C 15.231(c)
Test Method: ANSI C63.10 (2013) Section 6.9
Limit:

Frequency range(MHz)	Limit
70-900	No wider than 0.25% of the center frequency
Above 900	No wider than 0.5% of the center frequency

7.2.1 E.U.T. Operation

Operating Environment:

Temperature: 20 °C Humidity: 50 % RH Atmospheric Pressure: 1010 mbar

Test mode b:TX mode_Keep the EUT in transmitting with modulation mode.

7.2.2 Test Setup Diagram

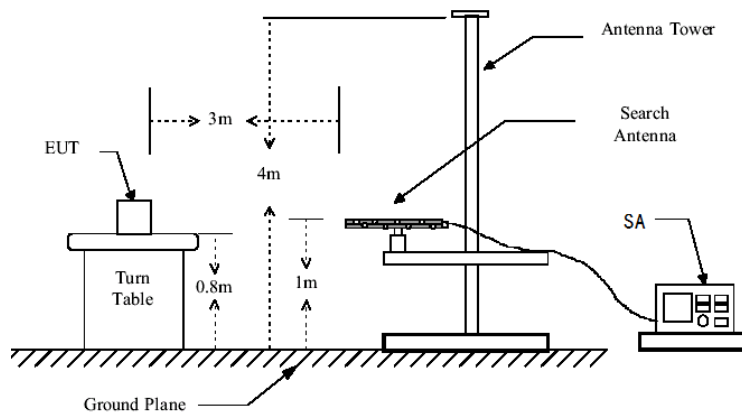

7.2.3 Measurement Procedure and Data

Frequency(MHz)	20dB bandwidth (kHz)	Limit (kHz)	Results
433.3	51.91	1083.25	Pass

Test plot as follows:

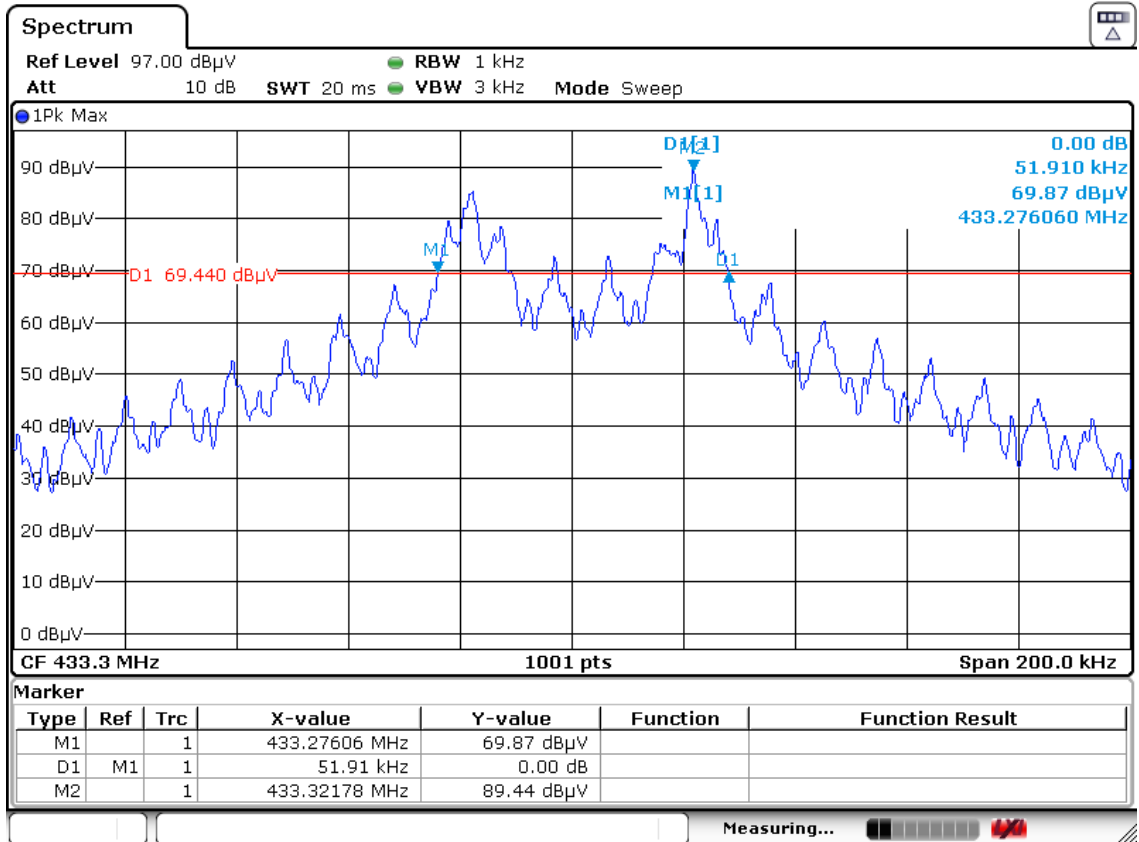

7.3 Dwell Time

Test Requirement 47 CFR Part 15, Subpart C 15.231(a)
Test Method: ANSI C63.10 (2013) Section 7.8.4
Limit: 15.231 (a): Not more than 5 seconds

7.3.1 E.U.T. Operation

Operating Environment:

Temperature: 20 °C Humidity: 50 % RH Atmospheric Pressure: 1010 mbar

Test mode b:TX mode_Keep the EUT in transmitting with modulation mode.

7.3.2 Test Setup Diagram

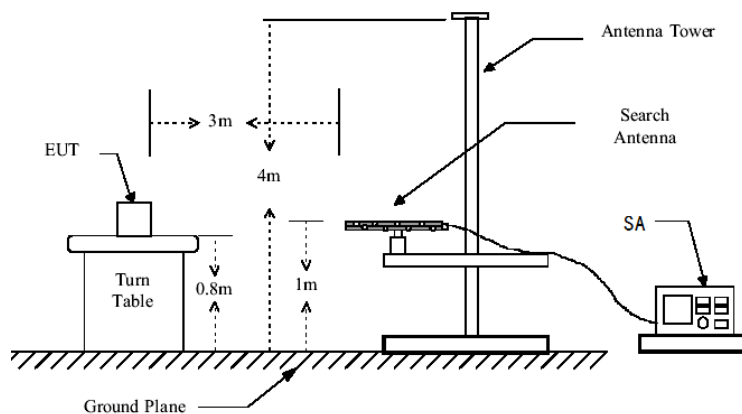

7.3.3 Measurement Procedure and Data

Test item	Limit (s)	Results
Transmission Duration	≤5s	Pass



Test plot as follows:

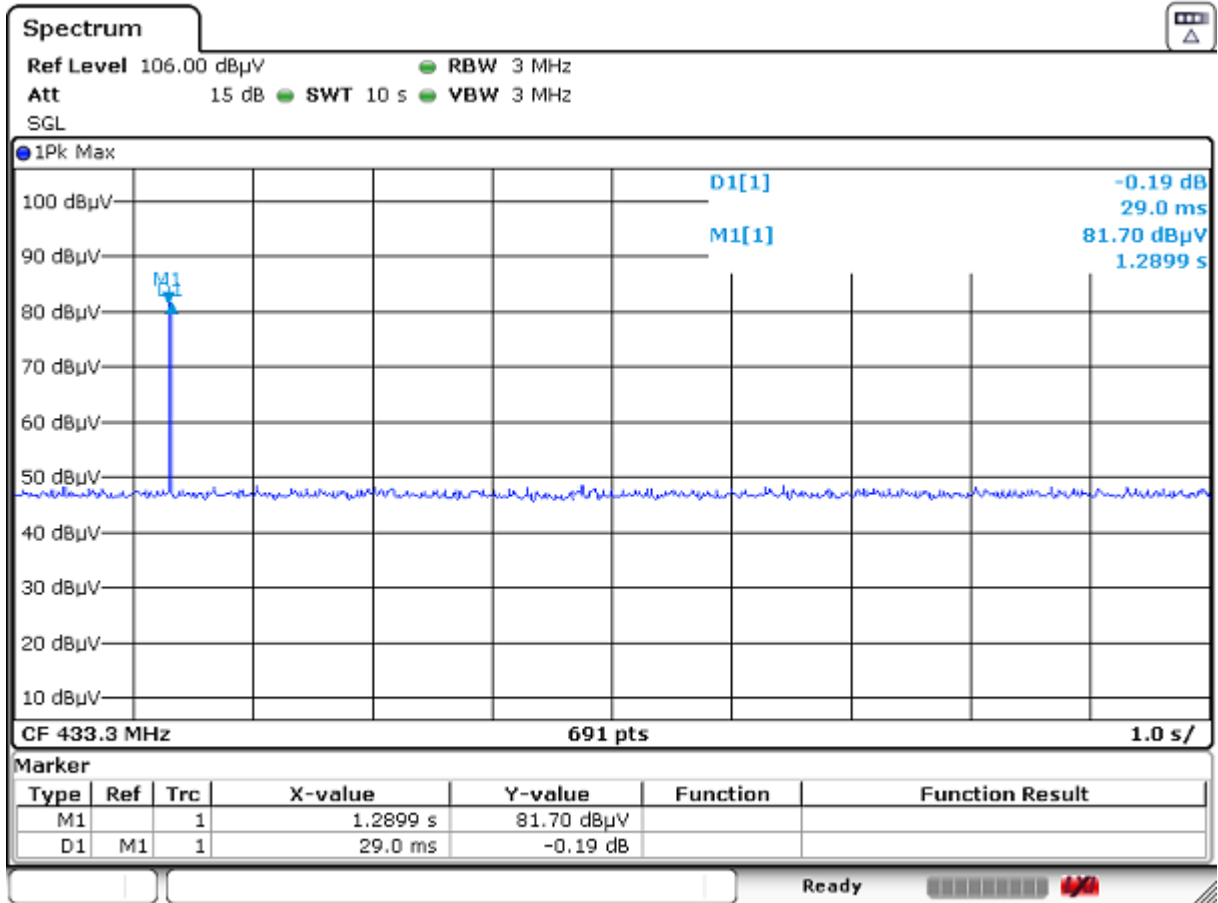

7.4 Field Strength of the Fundamental Signal (15.231(b))

Test Requirement 47 CFR Part 15, Subpart C 15.231(b)

Test Method: ANSI C63.10 (2013) Section 6.5

Limit:

Receiver Setup:

Frequency	Detector	RBW	VBW	Remark
0.009MHz-0.015MHz	Quasi-peak	200Hz	1KHz	Quasi-peak
0.015MHz-30MHz	Quasi-peak	9kHz	30KHz	Quasi-peak
30MHz-1GHz	Quasi-peak	120 kHz	300KHz	Quasi-peak
Above 1GHz	Peak	1MHz	3MHz	Peak
	Peak	1MHz	10Hz	Average

Limit:

(Spurious Emissions)

Frequency	Field strength (microvolt/meter)	Limit (dBuV/m)	Remark	Measurement distance (m)
0.009MHz-0.490MHz	2400/F(kHz)	-	Quasi-peak	300
0.490MHz-1.705MHz	24000/F(kHz)	-	Quasi-peak	30
1.705MHz-30MHz	30	-	Quasi-peak	30
30MHz-88MHz	100	40.0	Quasi-peak	3
88MHz-216MHz	150	43.5	Quasi-peak	3
216MHz-960MHz	200	46.0	Quasi-peak	3
960MHz-1GHz	500	54.0	Quasi-peak	3
Above 1GHz	500	54.0	Average	3
		74.0	Peak	3

Limit:

(Field strength of the fundamental signal)

Frequency	Limit (dBuV/m @3m)	Remark
433.09 - 434.61MHz	80.8	Average Value
	100.8	Peak Value

Test Procedure:

- The EUT was placed on the top of a rotating table 0.8 meters above the ground at a 3 meter semi-anechoic chamber. The table was rotated 360 degrees to determine the position of the highest radiation.
- The EUT was set 3 meters away from the interference-receiving antenna, which was mounted on the top of a variable-height antenna tower.
- The antenna height is varied from one meter to four meters above the ground to determine the maximum value of the field strength. Both horizontal and vertical polarizations of the antenna are set to make the measurement.
- For each suspected emission, the EUT was arranged to its worst case and then the antenna was tuned to heights from 1 meter to 4 meters (for the test frequency of below 30MHz, the antenna was tuned to heights 1 meter) and the rotatable table was turned from 0 degrees to 360 degrees to find the maximum reading.
- The test-receiver system was set to Peak Detect Function and Specified Bandwidth with Maximum Hold Mode.
- If the emission level of the EUT in peak mode was 10dB lower than the limit specified, then testing could be stopped and the peak values of the EUT would be reported. Otherwise the emissions that did not have 10dB margin would be re-tested one by one using peak, quasi-peak or average method as specified and then reported in a data sheet.
- The radiation measurements are performed in X, Y, Z axis positioning. And found the Z axis positioning which it is worse case, only the test worst case mode is recorded in the report.

7.4.1 E.U.T. Operation

Operating Environment:

Temperature: 20 °C Humidity: 50 % RH Atmospheric Pressure: 1010 mbar

Test mode b:TX mode_Keep the EUT in transmitting with modulation mode.

7.4.2 Test Setup Diagram

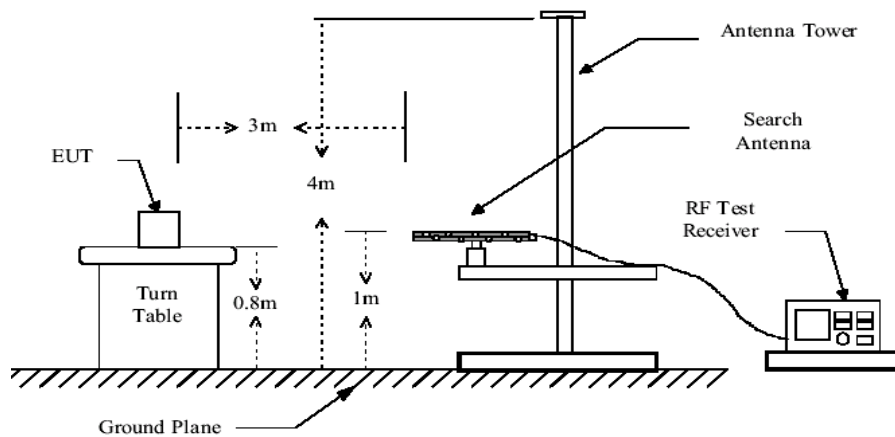

Figure1. 30MHz to 1GHz radiated emissions test configuration

7.4.3 Measurement Procedure and Data

- For below 1GHz, the EUT was placed on the top of a rotating table 0.8 meters above the ground at a 3 or 10 meter semi-anechoic chamber. The table was rotated 360 degrees to determine the position of the highest radiation.
- For above 1GHz, the EUT was placed on the top of a rotating table 1.5 meters above the ground at a 3 meter fully-anechoic chamber. The table was rotated 360 degrees to determine the position of the highest radiation.
- The EUT was set 3 or 10 meters away from the interference-receiving antenna, which was mounted on the top of a variable-height antenna tower.
- The antenna height is varied from one meter to four meters above the ground to determine the maximum value of the field strength. Both horizontal and vertical polarizations of the antenna are set to make the measurement.
- For each suspected emission, the EUT was arranged to its worst case and then the antenna was tuned to heights from 1 meter to 4 meters (for the test frequency of below 30MHz, the antenna was tuned to heights 1 meter) and the rotatable table was turned from 0 degrees to 360 degrees to find the maximum reading.
- The test-receiver system was set to Peak Detect Function and Specified Bandwidth with Maximum Hold Mode.
- If the emission level of the EUT in peak mode was 10dB lower than the limit specified, then testing could be stopped and the peak values of the EUT would be reported. Otherwise the emissions that did not have 10dB margin would be re-tested one by one using peak, quasi-peak or average method as specified and then reported in a data sheet.
- The radiation measurements are performed in X, Y, Z axis positioning. And found the X axis positioning which it is worse case, only the test worst case mode is recorded in the report.

Remark: Level= Read Level+ Cable Loss+ Antenna Factor- Preamp Factor



Test channel	Freq. (MHz)	Result Level (dB μ V/m)	Limit Line (dB μ V/m)	Over Limit (dB)	Detector	Polarization
Channel 1	433.3	99.55	100.8	-1.25	Peak	Vertical
		59.50	80.8	-21.3	Average	Vertical
		100.15	100.8	-0.65	Peak	Horizontal
		60.10	80.8	-20.7	Average	Horizontal

Remark: If the Peak value below the AV Limit, the AV test doesn't perform for this submission.

7.5 Radiated Emissions

Test Requirement 47 CFR Part 15, Subpart C 15.231(b)
Test Method: ANSI C63.10 (2013) Section 6.4&6.5&6.6
Limit:

Frequency(MHz)	Field strength(microvolts/meter)	Measurement distance(meters)
0.009-0.490	2400/F(kHz)	300
0.490-1.705	24000/F(kHz)	30
1.705-30.0	30	30
30-88	100	3
88-216	150	3
216-960	200	3
Above 960	500	3

Remark: The emission limits shown in the above table are based on measurements employing a CISPR quasi-peak detector except for the frequency bands 9-90kHz, 110-490kHz and above 1000 MHz. Radiated emission limits in these three bands are based on measurements employing an average detector, the peak field strength of any emission shall not exceed the maximum permitted average limits specified above by more than 20 dB under any condition of modulation.

7.5.1 E.U.T. Operation

Operating Environment:

Temperature: 20 °C Humidity: 50 % RH Atmospheric Pressure: 1010 mbar

Test mode b:TX mode_Keep the EUT in transmitting with modulation mode.

7.5.2 Test Setup Diagram

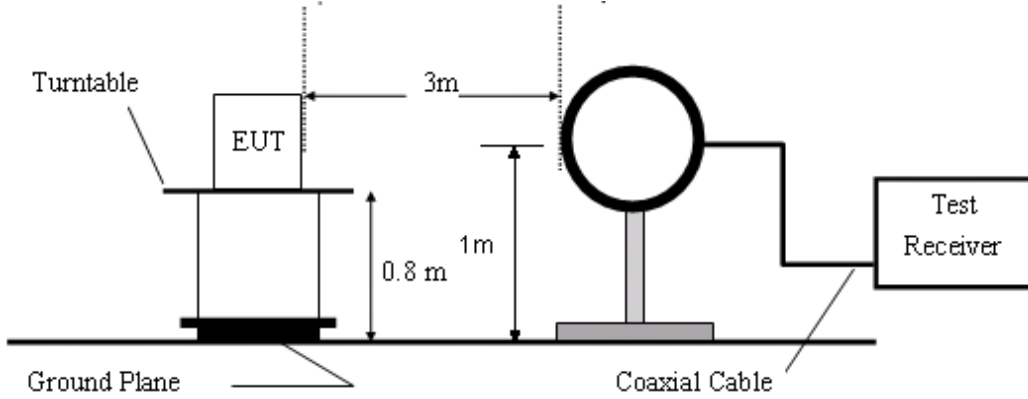

Figure1. Blow 30MHz radiated emissions test configuration

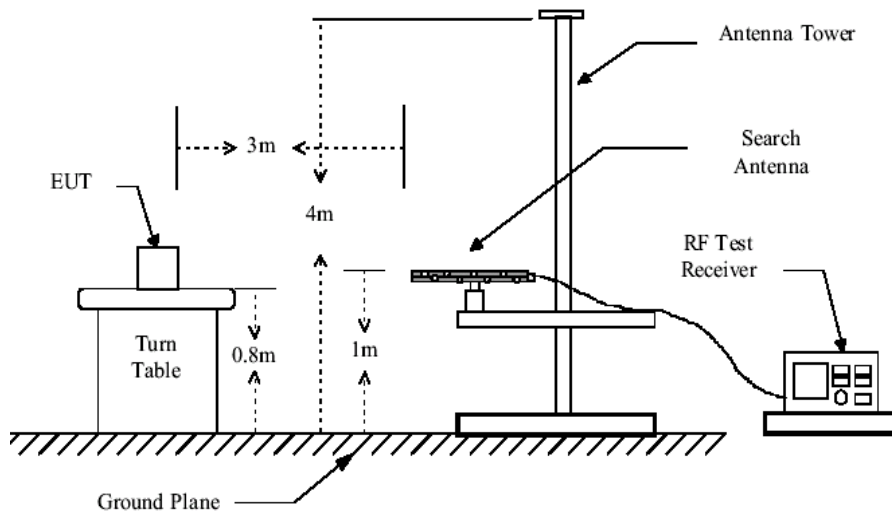

Figure2. 30MHz to 1GHz radiated emissions test configuration

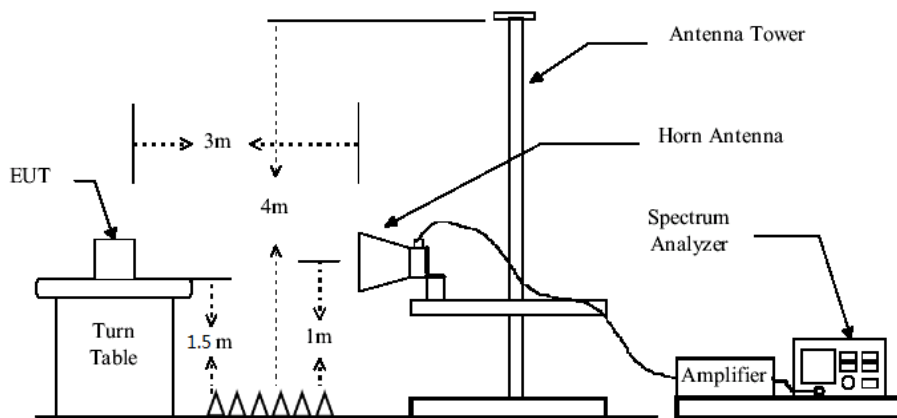

Figure3. Above 1GHz radiated emissions test configuration

7.5.3 Measurement Procedure and Data

- a. For below 1GHz, the EUT was placed on the top of a rotating table 0.8 meters above the ground at a 3 or 10 meter semi-anechoic chamber. The table was rotated 360 degrees to determine the position of the highest radiation.
- b. For above 1GHz, the EUT was placed on the top of a rotating table 1.5 meters above the ground at a 3 meter fully-anechoic chamber. The table was rotated 360 degrees to determine the position of the highest radiation.
- c. The EUT was set 3 or 10 meters away from the interference-receiving antenna, which was mounted on the top of a variable-height antenna tower.
- d. The antenna height is varied from one meter to four meters above the ground to determine the maximum value of the field strength. Both horizontal and vertical polarizations of the antenna are set to make the measurement.
- e. For each suspected emission, the EUT was arranged to its worst case and then the antenna was tuned to heights from 1 meter to 4 meters (for the test frequency of below 30MHz, the antenna was tuned to heights 1 meter) and the rotatable table was turned from 0 degrees to 360 degrees to find the maximum reading.
- f. The test-receiver system was set to Peak Detect Function and Specified Bandwidth with Maximum Hold Mode.
- g. If the emission level of the EUT in peak mode was 10dB lower than the limit specified, then testing could be stopped and the peak values of the EUT would be reported. Otherwise the emissions that did not have 10dB margin would be re-tested one by one using peak, quasi-peak or average method as specified and then reported in a data sheet.
- h. Test the EUT in the lowest channel, the middle channel, the Highest channel.
- i. The radiation measurements are performed in X, Y, Z axis positioning for Transmitting mode, and found the X axis positioning which it is the worst case.
- j. Repeat above procedures until all frequencies measured was complete.

Remark:

- 1) For emission below 1GHz, through pre-scan found the worst case is the lowest channel. Only the worst case is recorded in the report.
- 2) The field strength is calculated by adding the Antenna Factor, Cable Factor & Pre-amplifier. The basic equation with a sample calculation is as follows:
Final Test Level = Receiver Reading + Antenna Factor + Cable Factor – Pre-amplifier Factor
- 3) Scan from 9kHz to 6GHz, the disturbance below 30MHz was very low. The points marked on above plots are the highest emissions could be found when testing, so only above points had been displayed. The amplitude of spurious emissions from the radiator which are attenuated more than 20dB below the limit need not be reported.
- 4) For frequencies above 1GHz, the field strength limits are based on average limits. However, the peak field strength of any emission shall not exceed the maximum permitted average limits specified above by more than 20 dB under any condition of modulation. For the emissions whose peak level is lower than the average limit, only the peak measurement is shown

30MHz-1GHz

Vertical

100.0 dBuV/m

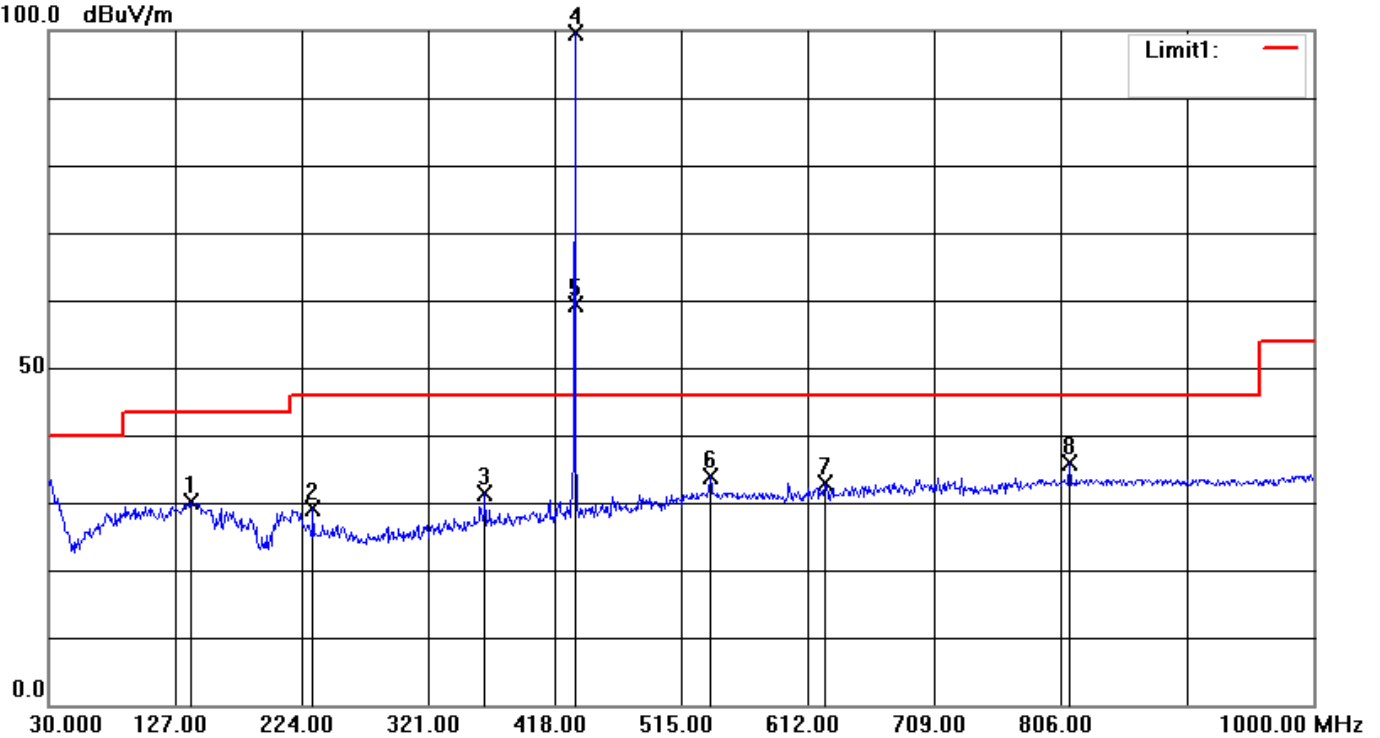

No.	Frequency (MHz)	Reading (dBuV)	Correct Factor (dB/m)	Result (dBuV/m)	Limit (dBuV/m)	Over Limit (dB)	Remark
1	138.6400	10.19	19.84	30.03	43.50	-13.47	QP
2	232.7300	10.84	18.38	29.22	46.00	-16.78	QP
3	364.6500	8.17	23.09	31.26	46.00	-14.74	QP
4	433.5200	75.26	24.29	99.55	100.8	-1.25	peak
5	433.5200	35.21	24.29	59.50	80.8	-21.3	AVG
6	537.3100	8.15	25.73	33.88	46.00	-12.12	QP
7	625.5800	5.96	26.87	32.83	46.00	-13.17	QP
8	812.7900	7.69	28.27	35.96	46.00	-10.04	QP

Horizontal

100.0 dBuV/m

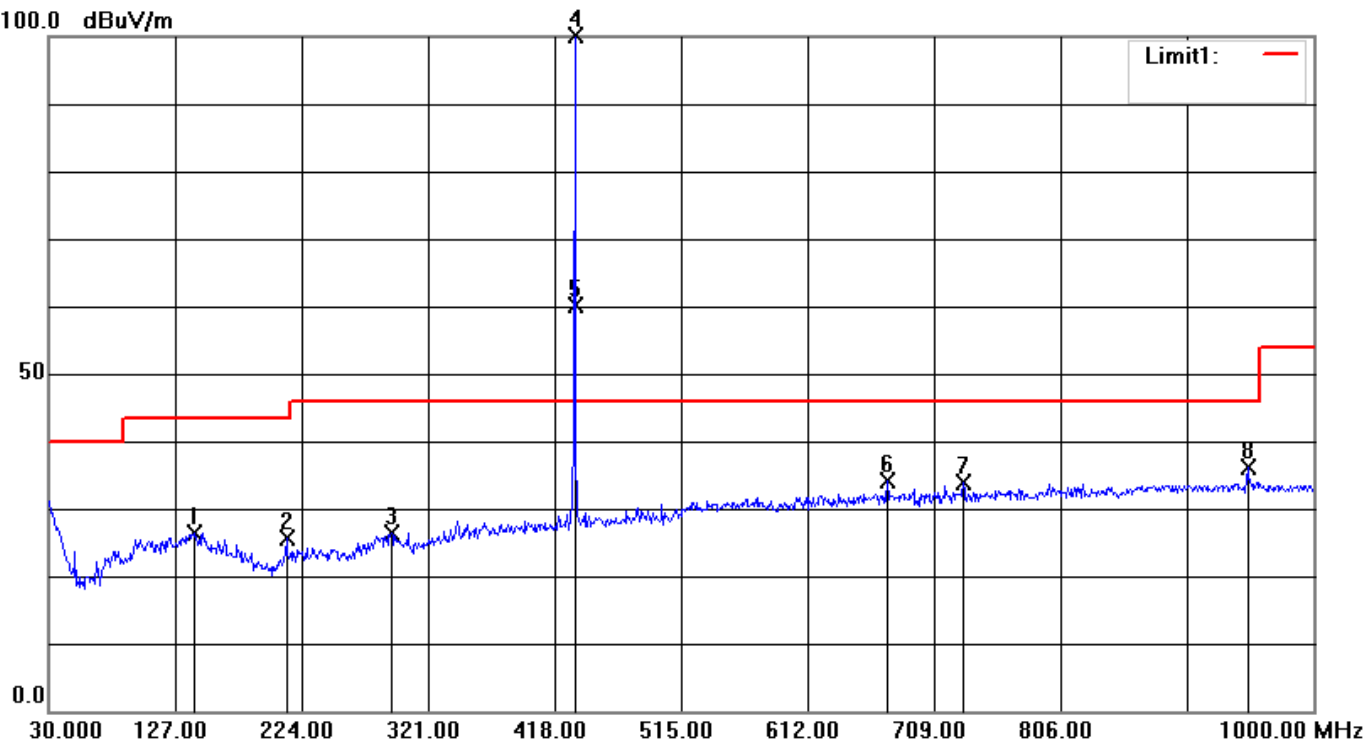

No.	Frequency (MHz)	Reading (dBuV)	Correct Factor(dB/m)	Result (dBuV/m)	Limit (dBuV/m)	Over Limit (dB)	Remark
1	141.5500	6.40	19.93	26.33	43.50	-17.17	QP
2	212.3600	8.48	17.12	25.60	43.50	-17.90	QP
3	292.8700	5.85	20.49	26.34	46.00	-19.66	QP
4	433.5200	75.86	24.29	100.15	100.8	-0.65	peak
5	433.5200	35.81	24.29	60.10	80.8	-20.7	AVG
6	673.1100	6.82	27.41	34.23	46.00	-11.77	QP
7	731.3100	5.97	27.83	33.80	46.00	-12.20	QP
8	949.5600	6.95	29.10	36.05	46.00	-9.95	QP



Above 1GHz

Mark	Frequency (MHz)	Reading (dBUV)	Factor (dB)	Emission (dBUV/m)	Limit (dBUV/m)	Over Limit (dB)	Detector	polarization
1	1730.000	54.42	-17.16	37.26	54.00	-16.74	peak	Vertical
2	2595.000	52.48	-14.39	38.09	54.00	-15.91	peak	Vertical
3	4675.000	50.74	-10.27	40.47	54.00	-13.53	peak	Vertical
4	2115.000	55.30	-16.22	39.08	54.00	-14.92	peak	Horizontal
5	3275.000	51.58	-13.00	38.58	54.00	-15.42	peak	Horizontal
6	4495.000	51.71	-11.03	40.68	54.00	-13.32	peak	Horizontal

Remark:

- 1) The field strength is calculated by adding the Antenna Factor, Cable Factor & Preamplifier. The basic equation with a sample calculation is as follows:
Final Test Level = Receiver Reading Level + Factor
Factor = Antenna Factor + Cable Factor – Preamplifier Factor
- 2) No any other emissions level which are attenuated less than 20dB below the limit. According to 15.31(o), the amplitude of spurious emissions from intentional radiators and emissions from unintentional radiators which are attenuated more than 20 dB below the permissible value need not be reported unless specifically required elsewhere in this Part. Hence there no other emissions have been reported.



8 Test Setup Photographs

Refer to the < Test Setup photos-FCC>.

9 EUT Constructional Details

Refer to the < External Photos > & < Internal Photos >.

- End of the Report -