

FCC RADIO TEST REPORT

FCC ID: 2APUP-SCCW01

Product : ROKK wireless charger

Trade Name : Scanstrut

Model Name : SC-CW-01

Serial Model : SC-CW-02, SC-CW-03, SC-CW-04,
SC-CW-05

Report No. : UNIA2018050219-1FR-01

Prepared for

Scanstrut Ltd.

5 Darts Business Park, Clyst St. George, Exeter, United Kingdom

Prepared by

Shenzhen United Testing Technology Co., Ltd.

2F, Annex Bldg, Jiahuangyuan Tech Park, #365 Baotian 1 Rd, Tiegang
Community, Xixiang Str, Bao'an District, Shenzhen, China

TEST RESULT CERTIFICATION

Applicant's name.....: Scanstrut Ltd.
Address.....: 5 Darts Business Park, Clyst St. George, Exeter, United Kingdom
Manufacture's Name.....: Huizhou Hengrun Industry Co.,Ltd.
Address.....: Room 408, Customs Clearance Center, Lixin Road, Zhongkai Hi-Tech. zone, Huizhou, Guangdong, P.R.China

Product description

Product name: ROKK wireless charger
Model name: SC-CW-01
Serial Model.....: SC-CW-02, SC-CW-03, SC-CW-04, SC-CW-05
Standards.....: FCC Rules and Regulations Part 15 Subpart C (Section 15.209)
Test procedure.....: ANSI C63.10-2013

This device described above has been tested by Shenzhen United Testing Technology Co., Ltd., and the test results show that the equipment under test (EUT) is in compliance with the FCC requirements. And it is applicable only to the tested sample identified in the report.

This report shall not be reproduced except in full, without the written approval of UNI, this document may be altered or revised by Shenzhen United Testing Technology Co., Ltd., personnel only, and shall be noted in the revision of the document.

Date of Test.....:

Date (s) of performance of tests.....: May 08, 2018 ~ May 18, 2018
Date of Issue: May 18, 2018
Test Result.....: Pass

Prepared by:

Kahn yang/Editor

Reviewer:

Sherwin Chan/Supervisor

Approved & Authorized Signer:

Liuze/Manager

Table of Contents	Page
1 . TEST SUMMARY	4
1.1 TEST PROCEDURES AND RESULTS	4
1.2 TEST FACILITY	4
1.3 MEASUREMENT UNCERTAINTY	4
2. GENERAL INFORMATION	5
2.1 General Description of EUT	5
2.2. Carrier Frequency of Channels	6
2.3 Operation of EUT during testing	6
2.4 Description of Test Setup	6
2.5 Measurement Instruments List	7
3. CONDUCTED EMISSION TEST	8
3.1 Block Diagram of Test Setup	8
3.2 Conducted Power Line Emission Limit	8
3.3 Test Procedure	8
3.4 Test Result	8
4. Occupied Bandwidth	11
4.1 Block Diagram of Test Setup	11
4.2 Rules and specifications	11
4.3 Test Procedure	11
4.4 Test Result	12
5. RADIA TED EMISSIONS	13
5.1 Block Diagram of Test Setup	13
5.2 Rules and specifications	14
5.3 Test Procedure	15
5.4 Test Result	15
6 ANTENNA REQUIREMENT	18
7. PHOTOGRAPH OF TEST	19
7.1 Radiated Emission	19
7.2 Conducted Emission	20

1. TEST SUMMARY

1.1 TEST PROCEDURES AND RESULTS

DESCRIPTION OF TEST	RESULT
CONDUCTED EMISSIONS TEST	COMPLIANT
OCCUPIED BANDWIDTH	COMPLIANT
RADIATED EMISSIONS	COMPLIANT
ANTENNA REQUIREMENT	COMPLIANT

1.2 TEST FACILITY

Test Firm : Shenzhen United Testing Technology Co., Ltd.

Address : 2F, Annex Bldg, Jiahuangyuan Tech Park, #365 Baotian 1 Rd, Tiegang Community, Xixiang Str, Bao'an District, Shenzhen, China

The testing quality ability of our laboratory meet with "Quality Law of People's Republic of China" Clause 19. The testing quality system of our laboratory meets with ISO/IEC-17025 requirements, which is approved by CNAS. This approval result is accepted by MRA of APLAC.

Our test facility is recognized, certified, or accredited by the following organizations:

CNAS-LAB Code: L6494

The EMC Laboratory has been assessed and in compliance with CNAS-CL01 accreditation criteria for testing Laboratories (identical to ISO/IEC 17025:2017 General Requirements) for the Competence of testing Laboratories.

Designation Number: CN1227

Test Firm Registration Number: 674885

The EMC Laboratory has been registered and fully described in a report filed with the (FCC) Federal Communications commission. The acceptance letter from the FCC is maintained in our files.

1.3 MEASUREMENT UNCERTAINTY

Measurement Uncertainty

Conducted Emission Expanded Uncertainty	= 2.23dB, k=2
Radiated emission expanded uncertainty(9kHz-30MHz)	= 3.08dB, k=2
Radiated emission expanded uncertainty(30MHz-1000MHz)	= 4.42dB, k=2
Radiated emission expanded uncertainty(Above 1GHz)	= 4.06dB, k=2

2. GENERAL INFORMATION

2.1 General Description of EUT

Equipment	ROKK wireless charger
Model Name	SC-CW-01
Serial No.	SC-CW-02, SC-CW-03, SC-CW-04, SC-CW-05
Trade Mark	N/A
Model Difference	All model's the function, software and electric circuit are the same, only with a product color and model named different. Test sample model: SC-CW-01.
FCC ID	2APUP-SCCW01
Antenna Type	Coil Antenna
Antenna Gain	0.2dBi
Operation frequency	125KHz
Number of Channels	1CH
Modulation Type	ASK
Battery	N/A
Power Source	DC 12V from adapter with AC 120V/60Hz
Adapter Model	M/N: EQ-24BCN Input: AC 100-240V, 50/60Hz, 0.8A Output: DC 12V, 2.0A

2.2. Carrier Frequency of Channels

Operation Frequency each of channel	
Channel	Frequency
01	125KHz

2.3 Operation of EUT during testing

Operating Mode

The mode is used: Transmitting mode

2.4 Description of Test Setup

Operation of EUT during testing

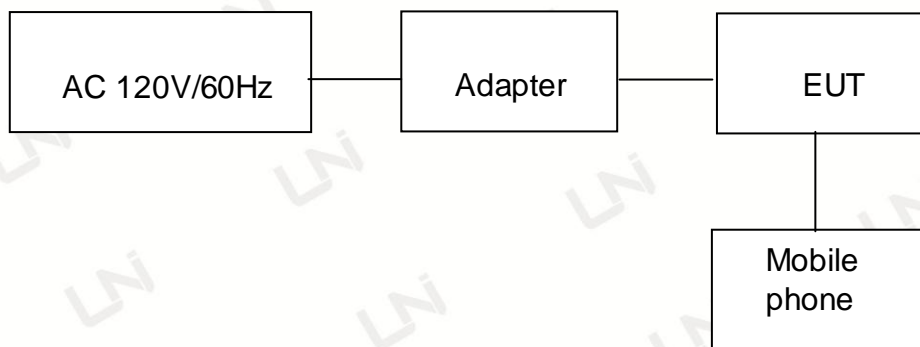

Setup: Transmission mode

Table for auxiliary equipment

Equipment Description	Manufacturer	Model	Calibration Due Date
Adapter	Kunxing	EQ-24BCN	N/A
USB Cable	Binshi	M1	N/A
Mobile phone	Haixin	M30T	N/A

2.5 Measurement Instruments List

Item	Equipment	Manufacturer	Model No.	Serial No.	Calibrated until
1	Horn Antenna	Sunol	DRH-118	A101415	2018.9.29
2	BicoNLog Antenna	Sunol	JB1 Antenna	A090215	2018.9.29
3	PREAMP	HP	8449B	3008A00160	2018.9.9
4	PREAMP	HP	8447D	2944A07999	2018.9.9
5	EMI TEST RECEIVER	Rohde&Schwarz	ESR3	101891	2018.9.9
6	VECTOR Signal Generator	Rohde&Schwarz	SMU200A	101521	2018.9.28
7	Signal Generator	Agilent	E4421B	MY4335105	2018.9.28
8	MXA Signal Analyzer	Agilent	N9020A	MY50510140	2018.9.28
9	MXA Signal Analyzer	Agilent	N9020A	MY51110104	2018.9.9
10	ANT Tower&Turn table Controller	Champro	EM 1000	60764	2018.9.28
11	Anechoic Chamber	Taihe Maorui	9m*6m*6m	966A0001	2018.9.9
12	Shielding Room	Taihe Maorui	6.4m*4m*3m	643A0001	2018.9.9
13	RF Power sensor	DARE	RPR3006W	15I00041SNO88	2019.3.14
14	RF Power sensor	DARE	RPR3006W	15I00041SNO89	2019.3.14
15	RF power divider	Anritsu	K241B	992289	2018.9.28
16	Wideband radio communication tester	Rohde&Schwarz	CMW500	154987	2018.9.28
17	Biconical antenna	Schwarzbeck	VHA 9103	91032360	2018.9.8
18	Biconical antenna	Schwarzbeck	VHA 9103	91032361	2018.9.8
19	Broadband Hybrid Antennas	Schwarzbeck	VULB9163	VULB9163#958	2018.9.8
20	Horn Antenna	Schwarzbeck	BBHA9120D	9120D-1680	2019.1.12
21	Active Receive Loop Antenna	Schwarzbeck	FMZB 1919B	00023	2018.11.02
22	Horn Antenna	Schwarzbeck	BBHA 9170	BBHA9170651	2019.03.14
23	Microwave Broadband Preamplifier	Schwarzbeck	BBV 9721	100472	2018.10.24
24	Active Loop Antenna	Com-Power	AL-130R	10160009	2019.05.10

3. CONDUCTED EMISSION TEST

3.1 Block Diagram of Test Setup

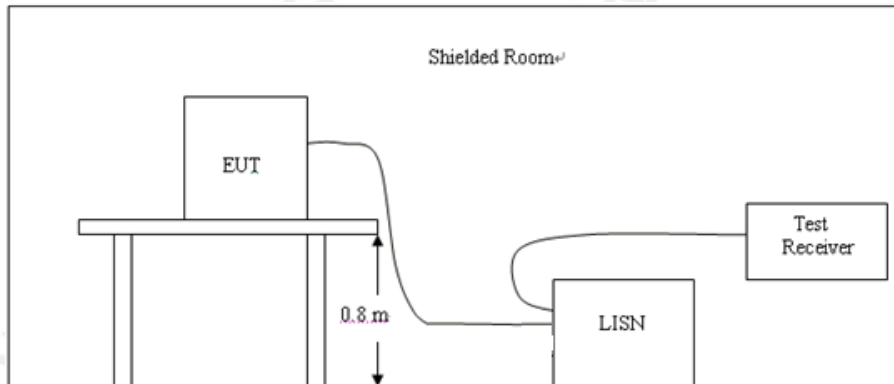

3.2 Conducted Power Line Emission Limit

For unintentional device, according to § 15.107 Line Conducted Emission Limits is as following

Frequency (MHz)	Maximum RF Line Voltage(dB μ V)			
	CLASS A		CLASS B	
	Q.P.	Ave.	Q.P.	Ave.
0.15~0.50	79	66	66~56*	56~46*
0.50~5.00	73	60	56	46
5.00~30.0	73	60	60	50

* Decreasing linearly with the logarithm of the frequency

For intentional device, according to §15.107Line Conducted Emission Limit is same as above table.

3.3 Test Procedure

- 1, The equipment was set up as per the test configuration to simulate typical actual usage per the user's manual. The EUT is a tabletop system, a wooden table with a height of 0.8 meters is used and is placed on the ground plane as per ANSI C63.10.
- 2, Support equipment, if needed, was placed as per ANSI C63.10.
- 3, All I/O cables were positioned to simulate typical actual usage as per ANSI C63.10.
- 4, If a EUT received DC power from the USB Port of Notebook PC, the PC's adapter received AC120V/60Hz power through a Line Impedance Stabilization Network (LISN) which supplied power source and was grounded to the ground plane.
- 5, All support equipments received AC power from a second LISN, if any.
- 6, The EUT test program was started. Emissions were measured on each current carrying line of the EUT using a spectrum Analyzer / Receiver connected to the LISN powering the EUT. The LISN has two monitoring points: Line 1 (Hot Side) and Line 2 (Neutral Side). Two scans were taken: one with Line 1 connected to Analyzer / Receiver and Line 2 connected to a 50 ohm load; the second scan had Line 1 connected to a 50 ohm load and Line 2 connected to the Analyzer / Receiver.
- 7, Analyzer / Receiver scanned from 150 KHz to 30MHz for emissions in each of the test modes

3.4 Test Result

PASS

Test Specification: Line

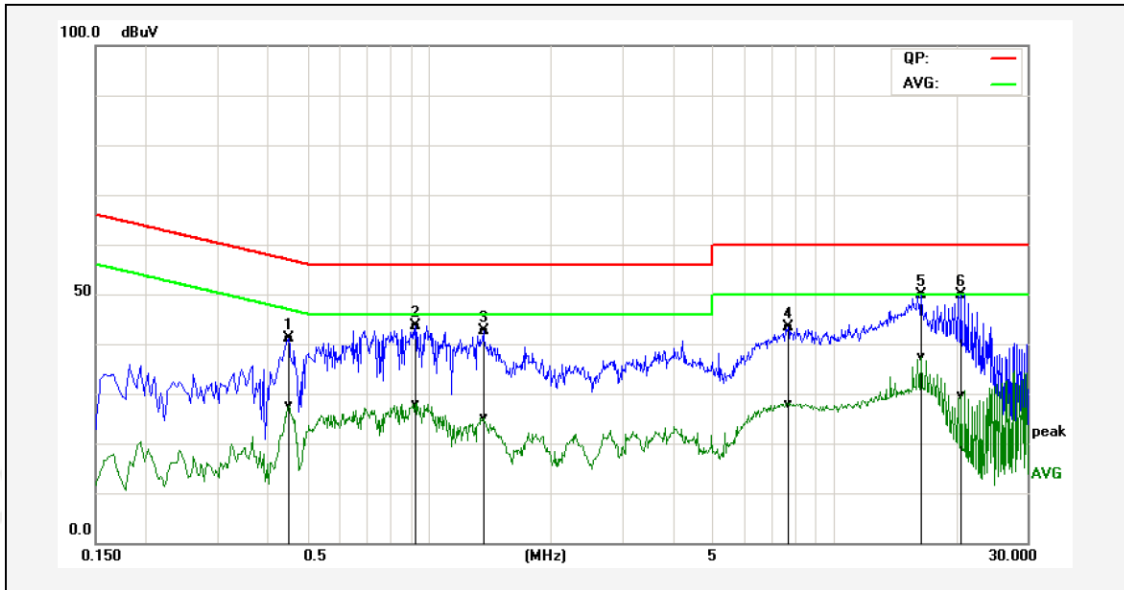

No.	Frequency (MHz)	QuasiPeak reading (dBuV)	Average reading (dBuV)	Correction factor (dB)	QuasiPeak result (dBuV)	Average result (dBuV)	QuasiPeak limit (dBuV)	Average limit (dBuV)	QuasiPeak margin (dB)	Average margin (dB)	Remark
1P	0.4500	31.16	17.70	10.03	41.19	27.73	56.88	46.88	-15.69	-19.15	Pass
2P	0.9260	33.59	17.67	10.10	43.69	27.77	56.00	46.00	-12.31	-18.23	Pass
3P	1.3660	32.54	15.06	10.17	42.71	25.23	56.00	46.00	-13.29	-20.77	Pass
4P	7.7100	33.38	17.78	10.10	43.48	27.88	60.00	50.00	-16.52	-22.12	Pass
5*	16.4820	39.60	27.12	10.31	49.91	37.43	60.00	50.00	-10.09	-12.57	Pass
6P	20.6980	39.30	19.17	10.58	49.88	29.75	60.00	50.00	-10.12	-20.25	Pass

Remark: Factor = Insertion Loss + Cable Loss, Result=Reading + Factor, Margin=Result – Limit.

Test Specification: Neutral

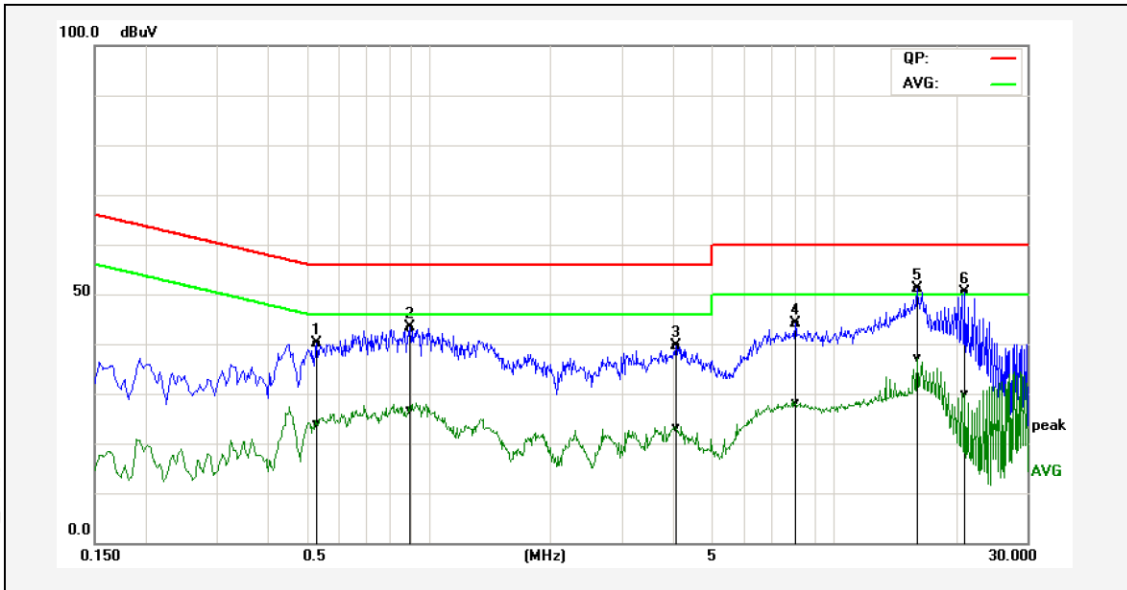

No.	Frequency (MHz)	QuasiPeak reading (dBuV)	Average reading (dBuV)	Correction factor (dB)	QuasiPeak result (dBuV)	Average result (dBuV)	QuasiPeak limit (dBuV)	Average limit (dBuV)	QuasiPeak margin (dB)	Average margin (dB)	Remark
1P	0.5299	30.08	13.72	10.05	40.13	23.77	56.00	46.00	-15.87	-22.23	Pass
2P	0.9020	33.15	16.58	10.10	43.25	26.68	56.00	46.00	-12.75	-19.32	Pass
3P	4.0860	29.38	12.89	10.13	39.51	23.02	56.00	46.00	-16.49	-22.98	Pass
4P	8.0580	34.05	17.99	10.06	44.11	28.05	60.00	50.00	-15.89	-21.95	Pass
5*	16.1020	40.79	26.80	10.34	51.13	37.14	60.00	50.00	-8.87	-12.86	Pass
6P	21.0900	39.96	19.46	10.48	50.44	29.94	60.00	50.00	-9.56	-20.06	Pass

Remark: Factor = Insertion Loss + Cable Loss, Result=Reading + Factor, Margin=Result – Limit.

4. Occupied Bandwidth

4.1 Block Diagram of Test Setup

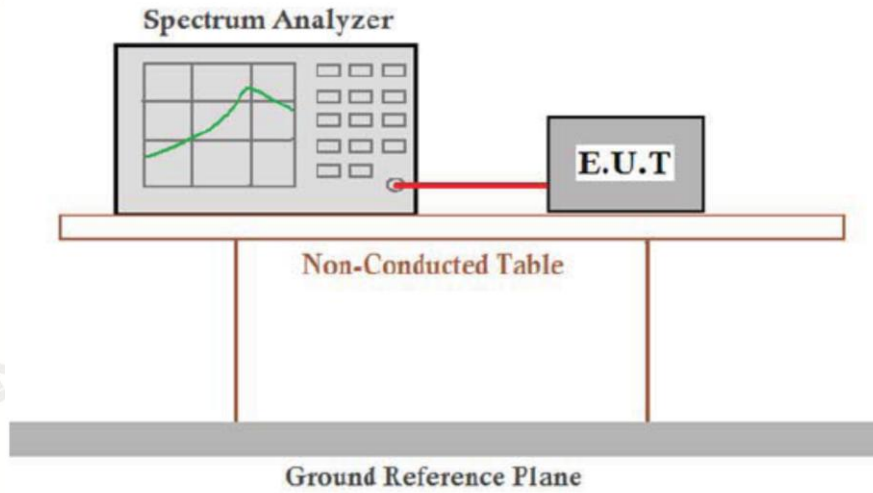

4.2 Rules and specifications

CFR 47 Part 15.215(c)

ANSI C63.10-2013

4.3 Test Procedure

Intentional radiators operating under the alternative provisions to the general emission limits, as contained in §§15.217 through 15.257 and in subpart E of this part, must be designed to ensure that 20dB bandwidth of the emission, or whatever bandwidth may otherwise be specified in the specific rule section under which the equip compliance with the 20dB attenuation specification may base on measurement at the intentional radiator's antenna output terminal unless the intentional radiator uses a permanently attached antenna, in which case compliance shall be demonstrated by measuring the radiated emissions.

4.4 Test Result

PASS

Mode	Frequency(KHz)	20dB Bandwidth (KHz)	Limit (kHz)	Conclusion
TX	125	2.946	/	PASS

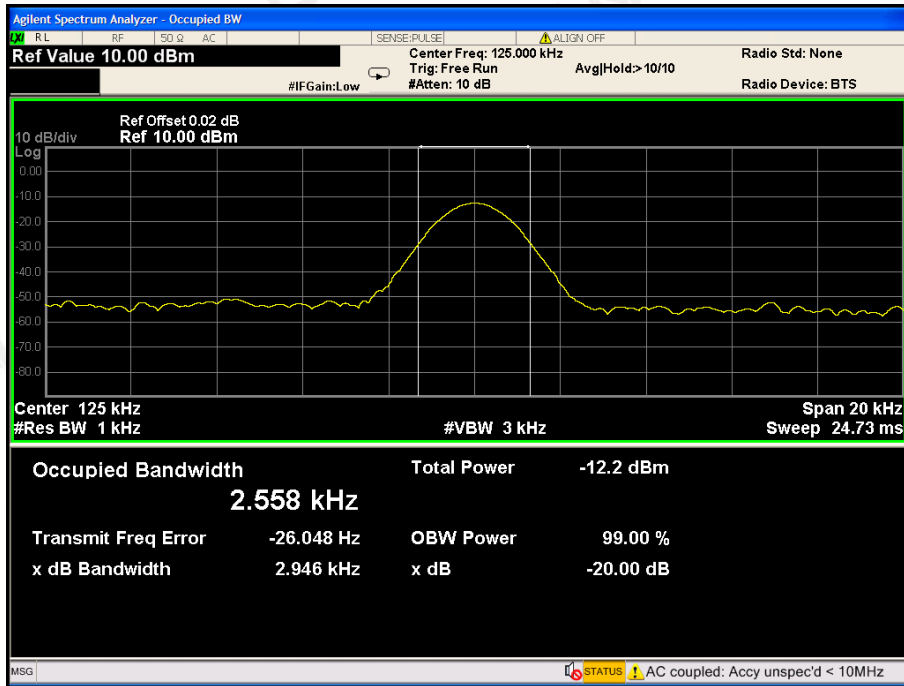

5. RADIATED EMISSIONS

5.1 Block Diagram of Test Setup

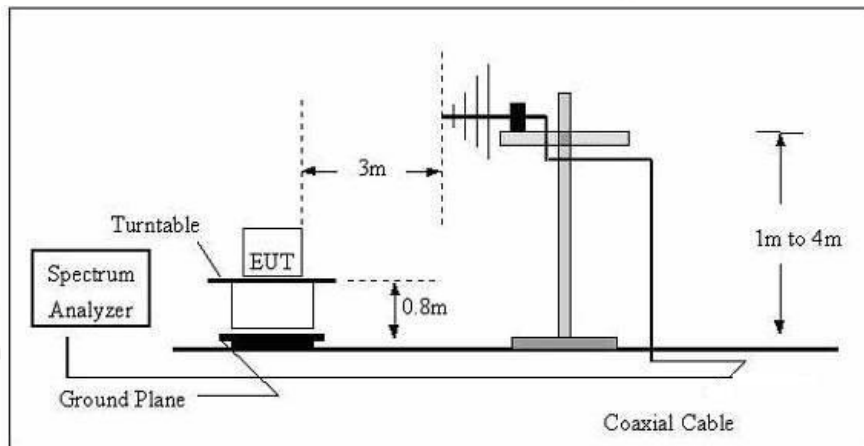
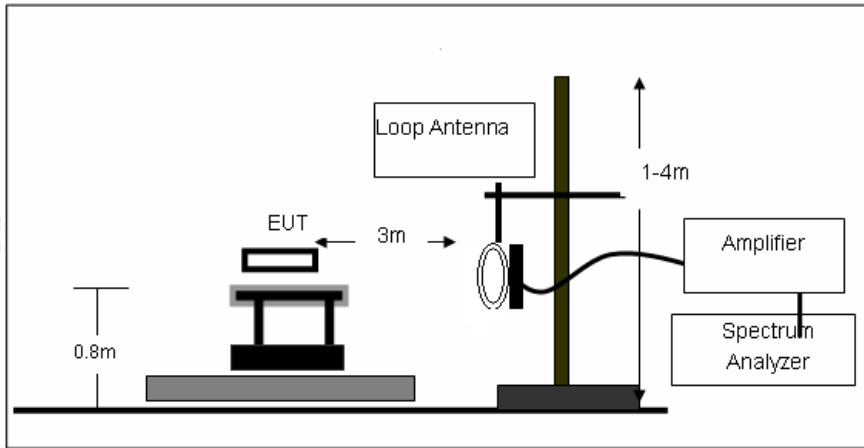

5.2 Rules and specifications

CFR 47 Part 15, section 15.205

Only spurious emissions are permitted in any of the frequency bands listed the tables in these sections.

MHz	MHz	MHz	GHz
0.090-0.110	16.42-16.423	399.9-410	4.5-5.15
1\ 0.495-0.505	16.69475-16.69525	608-614	5.35-5.46
2.1735-2.1905	16.80425-16.80475	960-1240	7.25-7.75
4.125-4.128	25.5-25.67	1300-1427	8.025-8.5
4.17725-4.17775	37.5-38.25	1435-1626.5	9.0-9.2
4.20725-4.20775	73-74.6	1645.5-1646.5	9.3-9.5
6.215-6.218	74.8-75.2	1660-1710	10.6-12.7
6.26775-6.26825	108-121.94	1718.8-1722.2	13.25-13.4
6.31175-6.31225	123-138	2200-2300	14.47-14.5
8.291-8.294	149.9-150.05	2310-2390	15.35-16.2
8.362-8.366	156.52475-156.52525	2483.5-2500	17.7-21.4
8.37625-8.38675	156.7-156.9	2690-2900	22.01-23.12
8.41425-8.41475	162.0125-167.17	3260-3267	23.6-24.0
12.29-12.293	167.72-173.2	3332-3339	31.2-31.8
12.51975-12.52025	240-285	3345.8-3358	36.43-36.5
12.57675-12.57725	322-335.4	3600-4400	(2)
13.36-13.41			

CFR 47 Part 15, section 15.209

The emissions from an intentional radiator shall not exceed the limits in the tables in these sections using an average detector

Frequency (MHz)	Field strength (microvolts/meter)	Measurement distance (meters)
0.009-0.490	2400/F(kHz)	300
0.490-1.705	24000/F(kHz)	30
1.705-30.0	30	30
30-88	100**	3
88-216	150**	3
216-960	200**	3
Above 960	500	3

Limit calculation and transfer to 3m distance as showed in the following table:

Frequency (MHz)	Limit (dBuV/m)	Distance (m)
0.009-0.490	20log(2400/F(KHz))+40log(300/3)	3
0.490-1.705	20log(24000/F(KHz))+40log(300/3)	3
1.705-30.0	69.5	3
30-88	40.0	3
88-216	43.5	3
216-960	46.0	3
Above 960	54.0	3

CFR 47 Part 15, section 15.35

When average radiated emission measurements are specified, the limit on the peak level of the radio Frequency emission is 20dB above the maximum permitted average emission limit.

Transmitter Spurious Emissions 9KHz-30MHz			
	9-150KHz	150-490KHz	490KHz-30MHz
Resolution Bandwidth	200Hz	9KHz	9KHz
Video Bandwidth	2KHz	100KHz	100KHz
Detector	Peak	Peak	Peak
Trace Mode	Max Hold	Max Hold	Max Hold
Sweep Time	Auto	Auto	Auto

5.3 Test Procedure

Measurement distance is 3m.

For the measurement range up to 30MHz in the following plots the field strength result from 3m Distance measurement are extrapolated to 300m and 30m distance respectively, by 40dB/decade, According to part 15.31(f)(2), per antenna factor scaling.

Measurements below 1000MHz are performed with a peak detector and compared to average limits, Measurements with an average detector are not required.

Note: For battery operated equipment, the equipment tests shall be performed using a new battery.

5.4 Test Result

PASS

For 9KHz-30MHz

Freq. (MHz)	Detector Mode (PK/QP)	Reading (dBuV)	Factor (dB)	Actual FS (dBuV/m)	Limits 3m (dBuV/m)	Margin (dBuV/m)
0.206	Peak	24.82	25.02	49.84	126.77	76.93
0.386	Peak	43.26	25.02	68.28	125.67	57.39
0.508	Peak	24.03	25.28	49.31	113.71	64.40
0.624	Peak	27.61	25.28	52.89	113.62	60.73
N/A						

For 30MHz-1GHz

Antenna polarity: H

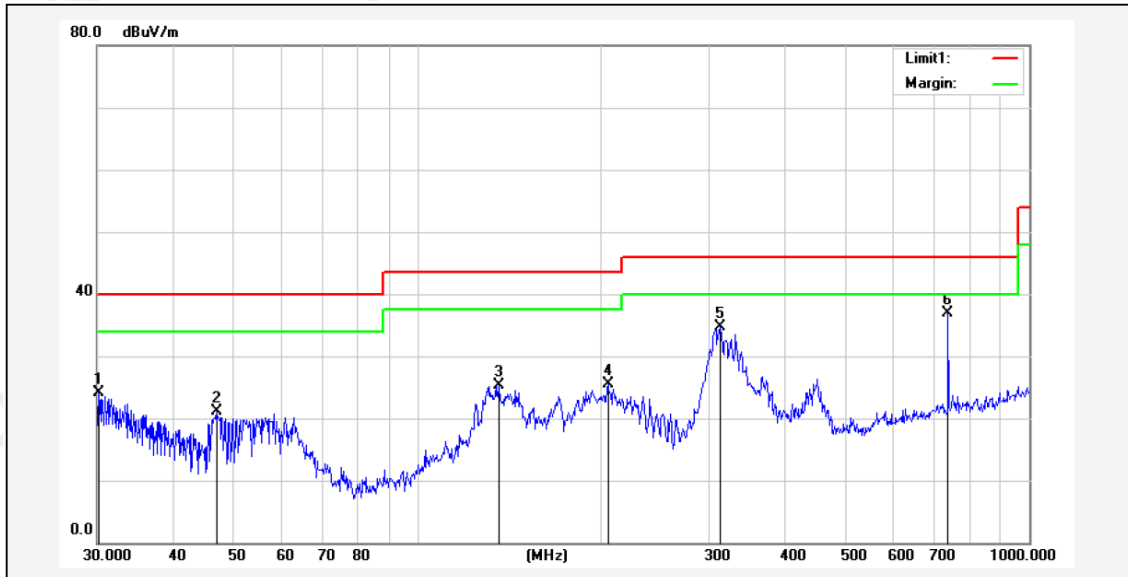

No.	Frequency (MHz)	Reading (dBuV)	Correction factor(dB/m)	Result (dBuV/m)	Limit (dBuV/m)	Margin (dB)	Degree (deg.)	Height (cm)	Remark
1	30.2111	30.82	-6.72	24.10	40.00	-15.90			peak
2	46.9948	40.91	-19.76	21.15	40.00	-18.85			peak
3	135.9822	39.52	-14.20	25.32	43.50	-18.18			peak
4	204.9551	40.52	-15.01	25.51	43.50	-17.99			peak
5	312.1794	46.68	-11.90	34.78	46.00	-11.22			peak
6*	737.0714	42.08	-5.22	36.86	46.00	-9.14			peak

Remark: Absolute Level= Reading Level+ Factor, Margin= Absolute Level – Limit
 Factor=Ant. Factor + Cable Loss – Pre-amplifi

Antenna polarity: V

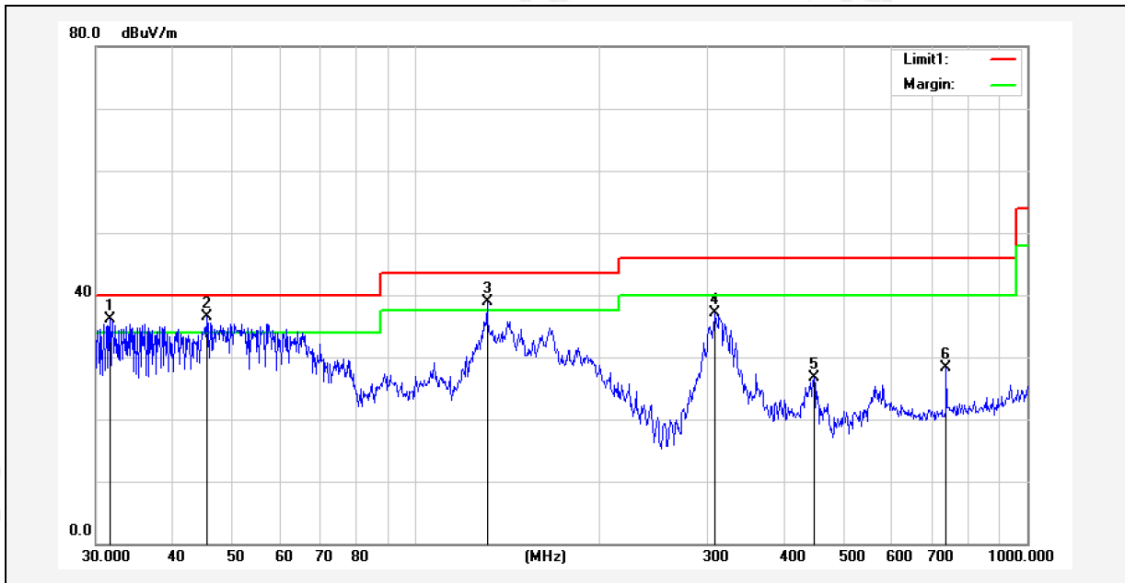

No.	Frequency (MHz)	Reading (dBuV)	Correction factor(dB/m)	Result (dBuV/m)	Limit (dBuV/m)	Margin (dB)	Degree (deg.)	Height (cm)	Remark
1!	31.6202	44.05	-8.01	36.04	40.00	-3.96			peak
2*	45.5348	55.42	-18.87	36.55	40.00	-3.45			peak
3!	130.8369	52.95	-14.01	38.94	43.50	-4.56			peak
4	308.9126	49.07	-11.88	37.19	46.00	-8.81			peak
5	447.9822	36.88	-10.25	26.63	46.00	-19.37			peak
6	737.0714	33.44	-5.22	28.22	46.00	-17.78			peak

Remark: Absolute Level= Reading Level+ Factor, Margin= Absolute Level – Limit
 Factor=Ant. Factor + Cable Loss – Pre-amplifier

Remark:

- (1) Measuring frequencies from 9 KHz to the 1 GHz, Radiated emission test from 9KHz to 30MHz was verified, and no any emission was found except system noise floor.
- (2) * denotes emission frequency which appearing within the Restricted Bands specified in provision of 15.205, then the general radiated emission limits in 15.209 apply.
- (3) The IF bandwidth of EMI Test Receiver between 30MHz to 1GHz was 120KHz, 1 MHz for measuring above 1 GHz, below 30MHz was 10KHz.

6 ANTENNA REQUIREMENT

Standard Applicable:

For intentional device, according to FCC 47 CFR Section 15.203, an intentional radiator shall be designed to ensure that no antenna other than that furnished by the responsible party shall be used with the device.

Antenna Connected Construction

The antenna used in this product is a Coil Antenna, The directional gains of antenna used for transmitting is 0.2dBi.

ANTENNA

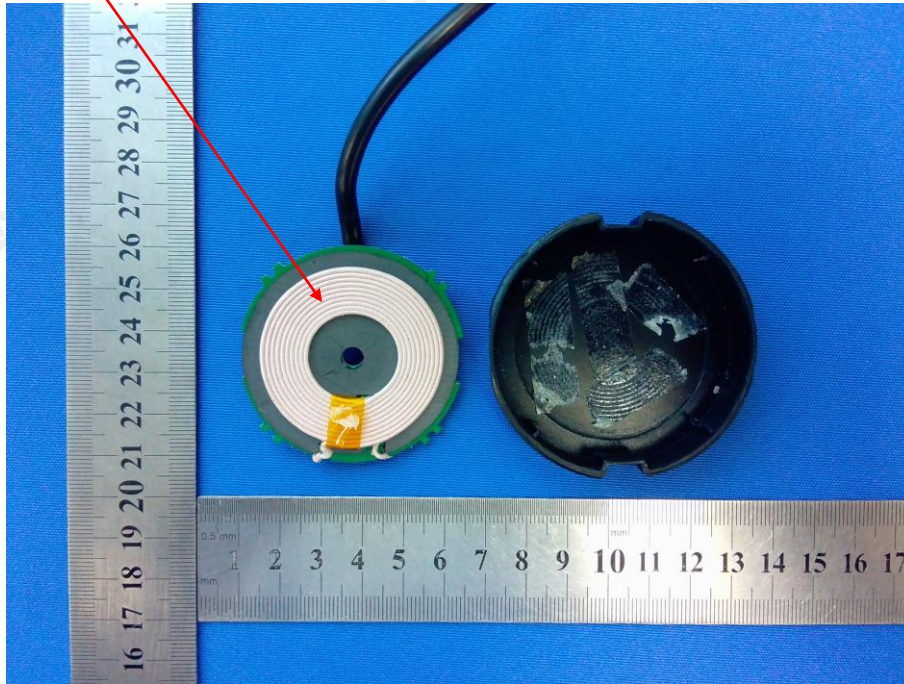

7. PHOTOGRAPH OF TEST

7.1 Radiated Emission

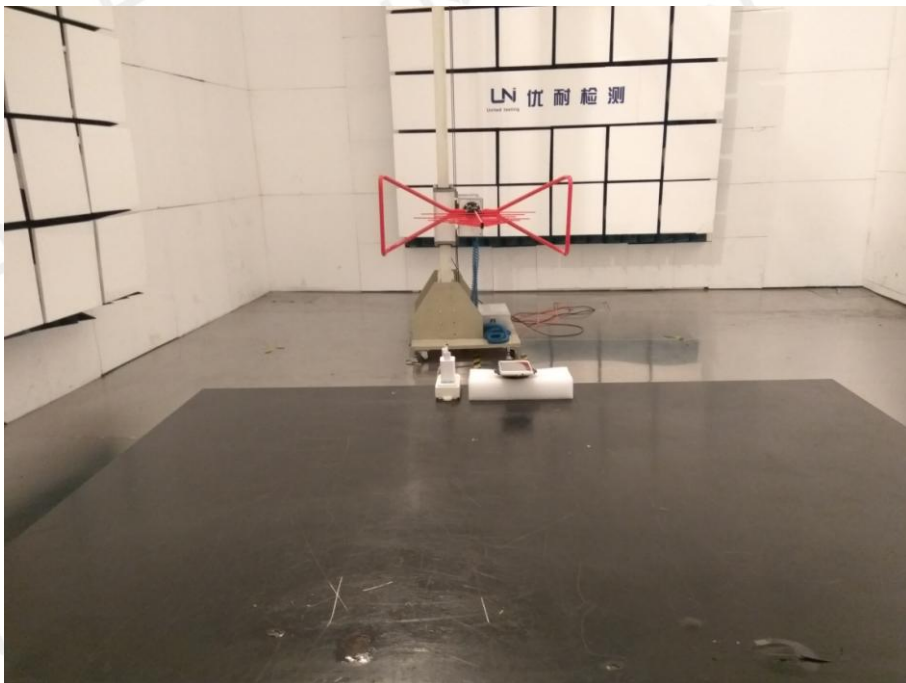

7.2 Conducted Emission



End of Report