

## 承 認 書



## SPECIFICATION FOR APPROVAL

|                       |   |
|-----------------------|---|
| 客 戶:<br>CUSTOMER:     | 惠州市宇然科技有限公司<br>Huizhou Yuran Technology Co., LTD  |
| 客 戶 規 格:<br>CUST P/N: | A6 三线圈, 侧面出线, 感值 7.0UH+/-10%, 两边 9TS. 中间<br>10TS  |
| 料 號:<br>FINE P/N:     | 12600501315   |
| 產 品 型 號:<br>DESC:     | F24x19-9Ts/10TS-3coil-0.08x105P-11mm  |
| 日 期:<br>DATE:         | 2024/05/18  |
| 版 本:<br>Version:      | A.0  |

| 擬制<br>PREPARED BY | 審核<br>CHECKED BY | 批准<br>APPROVED BY | 客戶承認<br>CUSTOMER APPROVE |
|-------------------|------------------|-------------------|--------------------------|
| 黃燕銘               | 寧元安              | 黃錦華               |                          |

## 東莞市西聯干城科技有限公司

Dongguan City west united dry city technology Co., LTD

工廠地址: 東莞市東坑鎮駿發路 123 號三甲高新技術產業園 2 棟 8 樓

Factory address: 8th Floor, Building 2, Sanjia High-tech Industrial Park, No.123  
Junfa Road, Dongkeng Town, Dongguan City

TEL: 0769-82989169

FAX: 0769-82989169

E-mail: amang198204@163.com



# SPECIFICATION

|               |                                      |                |                |  |
|---------------|--------------------------------------|----------------|----------------|--|
| 產品型號:<br>DESC | F24x19-9Ts/10TS-3coil-0.08x105P-11mm | 版本<br>Rev: A.0 | 客戶 CUST:       |  |
|               |                                      |                | 料号 Fine P/N:   |  |
|               |                                      |                | 客户料号 CUST P/N: |  |

一、尺寸 DIMENSION:(mm)

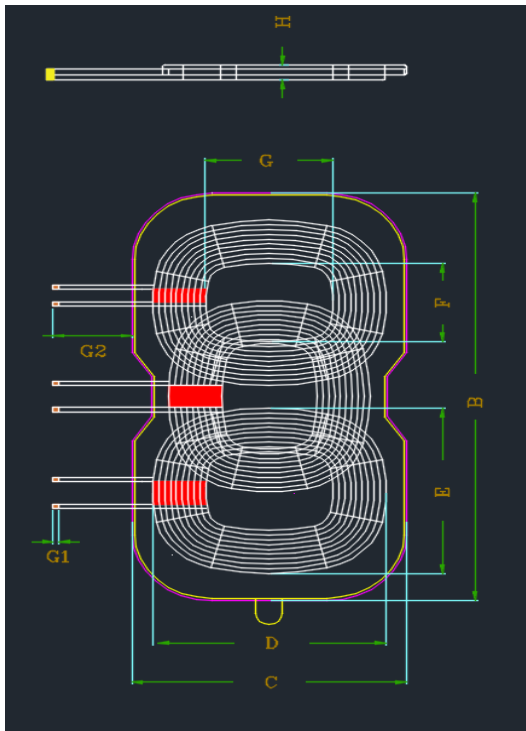

|    |          |
|----|----------|
| B  | 93.0±1.0 |
| C  | 51.5±0.5 |
| D  | 48±1     |
| E  | 40±1.0   |
| F  | 20±1     |
| G  | 29±1.0   |
| G1 | 3±1.0    |
| G2 | 11+2     |
| H  | 3.6±0.3  |

注:

- 1.单个磁片尺寸为 F46.5\*52.0mm 厚度 0.9mm±0.1,贴双面胶粘接,并且带手撕位;
- 2.上线圈出线位置缠 8mm

二、原理图 SCHEMATIC DIAGRAM:

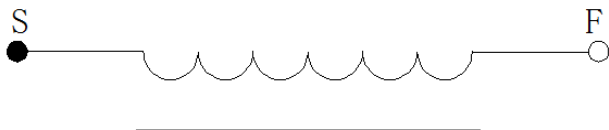

三、绕线参数 Winding Specification:

| 序号<br>NO. | 端子<br>TERMINAL |   | 线径<br>WIRE    | 圈数<br>Turns | 绕线方向<br>Winding Direction |
|-----------|----------------|---|---------------|-------------|---------------------------|
| 1         | S              | F | 丝包线 0.08*105P | 9Ts/10TS    | CCW                       |

四、电气特性 ELECTRICAL CHARACTERISTICS:

温度 TEMPERATURE:25±10℃, 湿度 RELATIVE HUMIDITY:65±20%

| 序号<br>NO. | 项目<br>ITEM | 端子<br>TERMINAL | 标准<br>SPECIFICATION | 测试条件<br>TEST FREQUENCY | 测试仪器<br>TEST EQUIPMENTS |
|-----------|------------|----------------|---------------------|------------------------|-------------------------|
| 1         | IND.       | S-F            | 3.8uH±10% 单独线圈      | 100KHz/1.0V            | LCZ METER 1062B         |
| 2         | IND.       | S-F            | 7.0uH±10% 加贴磁片      | 100KHz/1.0V            | LCZ METER 1062B         |
| 3         | DCR        | S-F            | ≤55mΩ               | 100KHz/1.0V            | LCZ METER 1062B         |
| 4         | Q          | S-F            | ≥82                 | 100KHz/1.0V            | LCZ METER 1062B         |

|   |  |
|---|--|
| 擬制/日期 PREPARED BY/DATE<br>黄燕铭 2024/5/18 | 審核/日期 CHECKED BY/DATE<br>黄锦华 2024/5/18 |
|---|--|

